

Safeflex sliding mesh

User Information

Instructions for assembly and use (Method statement)

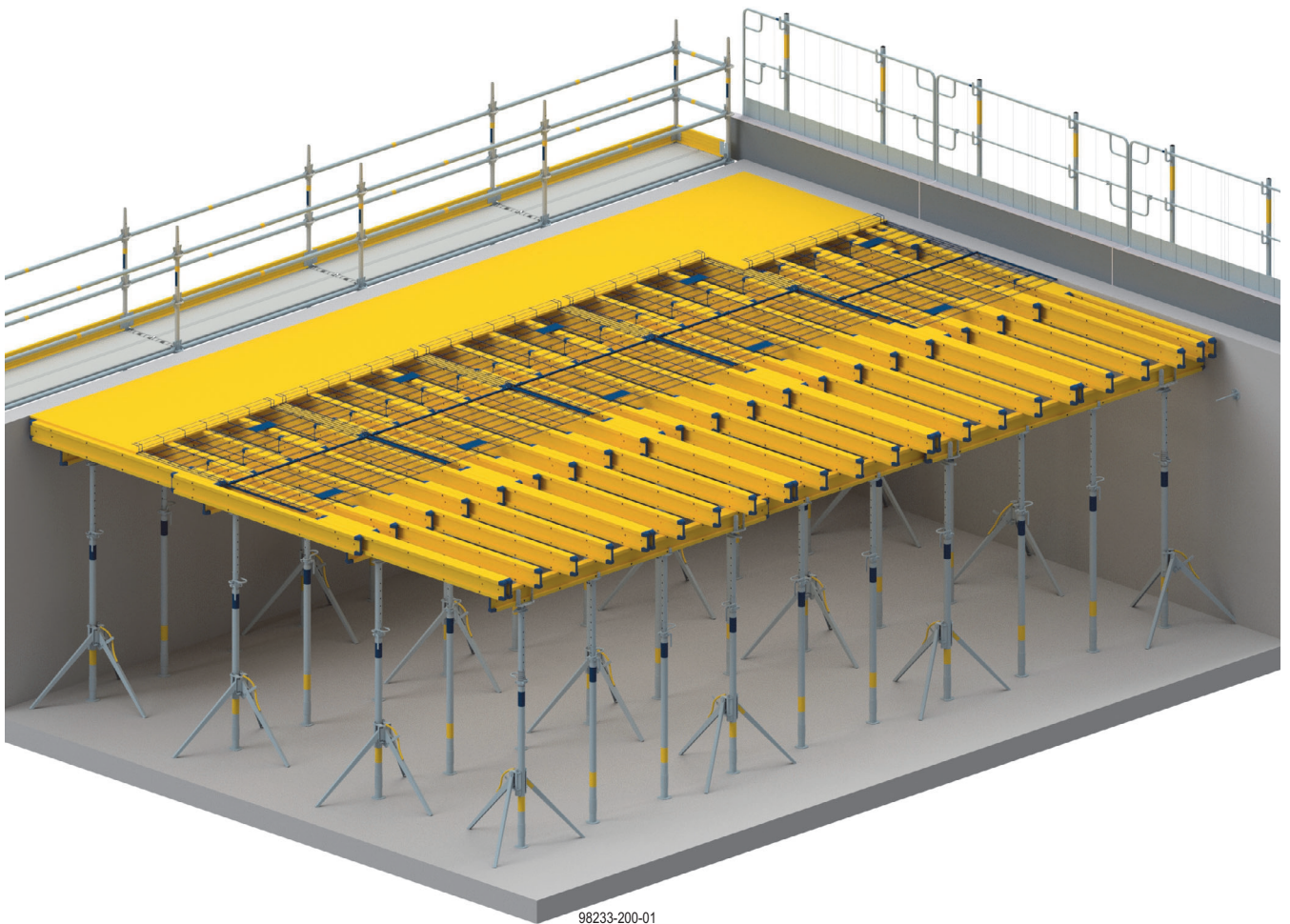

Contents

- 3 Product description
- 4 Instructions for assembly and use (Method statement)
- 10 Technical condition
- 11 Transporting, stacking and storing

15 Article list

Product description



NOTICE

This document is only valid in combination with the underlying User Information booklet 'Dokaflex' or 'Safeflex'!

Safeflex sliding meshes are a through-fall-proof aid for laying formwork sheets and can be used in combination with the Dokaflex beam floor formwork or as an alternative to system meshes in combination with the Safeflex beam floor formwork in CIP concreting.

The commonly used system components are sufficient for this purpose. The basic assembly and disassembly procedures are the same as for standard use.

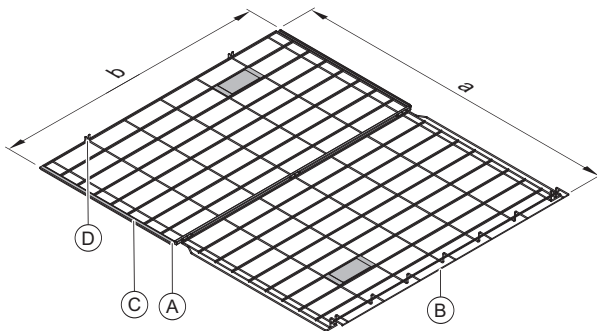

		Safeflex sliding mesh	
		2.00m	2.50m
a	Depth (folded open)	2.50m	
	Depth (folded closed)	1.40m	
b	Width	2.00m	2.50m

A	Folding mechanism
B	Upturn
C	Guide rails
D	Transport lock (new version only)

Features of the sliding mesh:

- Tested according to 'DGUV Test' 'GS-Bau 18' (version 05/2020).
- Blue, powder-coated.
- Widths of the sliding meshes are matched to the common formwork sheet sizes.
- Folding mechanism (A) for easy transport of the sliding meshes and for versatile infilling at obstacles.

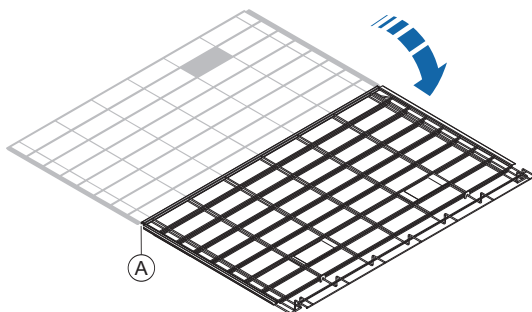

- Upturn (B) at the sheet side makes it easier to manoeuvre the formwork sheet into place and slide the sliding meshes into position.

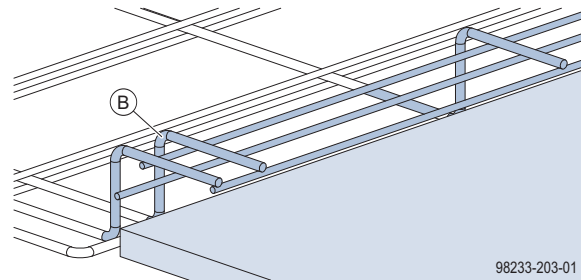

- Guide rails (C) on each side of the meshes enable safe and precise sliding of the sliding meshes.

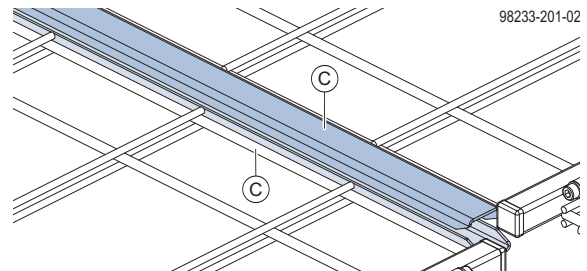

- Transport lock (D) for non-slip stacking of the sliding meshes (new version only).

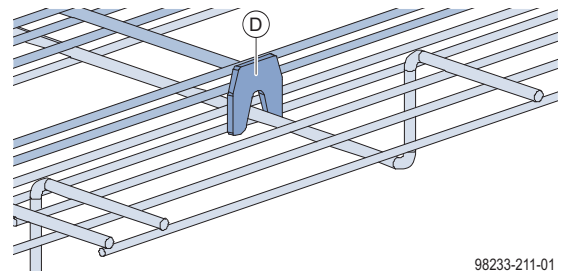

NOTICE

Sliding mesh without transport lock: Follow the instructions for [Transporting, stacking and storing!](#)

Instructions for assembly and use (Method statement)

Deviations from Dokaflex and Safeflex with system meshes

Note the following deviations from the information provided in the 'Dokaflex' and 'Safeflex' User Information booklets:



WARNING

Danger of sliding meshes overturning in the event of a fall!

To ensure that the sliding meshes function correctly in preventing through-falls, always support the following areas with additional H20 secondary beams:

- ▶ Sheet-to-sheet and mesh-to-mesh joints (Fig. 1)
- ▶ Wall junction (Fig. 2)

In this way, the sliding meshes are always securely supported.

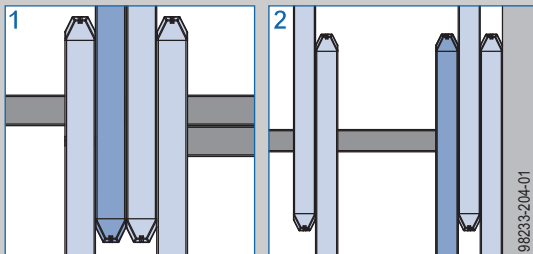

Max. centre-to-centre spacing of the secondary beams: 50 cm

Short Instruction

Safe laying of the formwork sheets with the assistance of the Safeflex sliding mesh is performed on beam floor formwork erected beforehand.



Observe the directions in the 'Dokaflex' or 'Safeflex' User Information booklet.

- ▶ Install propping and primary beams.
- ▶ Place the secondary beams on the primary beams. (See section [Deviations from Dokaflex and Safeflex with system meshes!](#))

The action steps below are described in detail in the corresponding sections of the same name.

[Laying sliding meshes on formwork](#)

- ▶ Variant 1: [Working from below to lay sliding meshes](#)
- ▶ Variant 2: [Working off working platform or working scaffold to lay sliding meshes](#)

[Laying formwork sheets](#)

- ▶ [Laying formwork sheets in the typical zone](#)

- ▶ [Laying formwork sheets in the closure zone](#)

Usage situation 1: [Closure zone in sliding direction](#)
Usage situation 2: [Closure zone transverse to sliding direction](#)

- ▶ [Laying formwork sheets at obstacles](#)

Variant 1: [Skipping past obstacle](#)
Variant 2: [Bypassing obstacle on one side](#)

Laying sliding meshes on formwork

The variants below are described in detail in the corresponding sections of the same name:

- Variant 1: [Working from below to lay sliding meshes](#)
- Variant 2: [Working off working platform or working scaffold to lay sliding meshes](#)



NOTICE

- The sliding mesh is intended exclusively as through-fall protection and stepping on it is prohibited.



- In the area of the sheet-to-sheet joint, sliding meshes must have full-length support on the secondary beams.

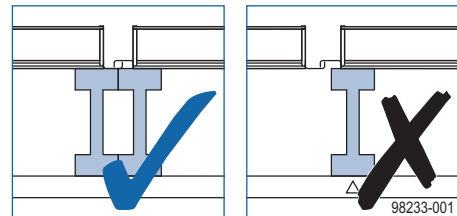

- The sliding meshes laid guide rail to guide rail (A) must engage with each other. In this way the sliding meshes are guided correctly.

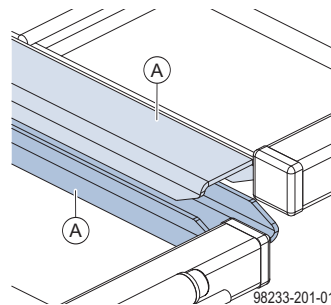

Working from left to right when laying the sliding meshes enables the guide rails to engage easily with each other.

Working from below to lay sliding meshes

Wheel-around scaffold DF



- Collapsible wheel-around platform made of light alloy
- Variable working heights of up to 3.50 m (max. platform height: 1.50 m)
- Width of scaffold: 0.75 m



NOTICE

When work is being carried out near drop-off edges (i.e. at a distance of < 2 m), the Wheel-around scaffold DF accessory set (consisting of a toeboard and intermediate guardrail) is needed.



Follow the directions in the User Information booklet!

Platform stairway 0.97m



- Mobile folding platform stairway made of light alloy
- Working heights of up to 3.00 m (height of top step 0.97 m)
- Stair width: 1.20 m



NOTICE

Minimum distance **a** from drop-off edge: 2.00 m

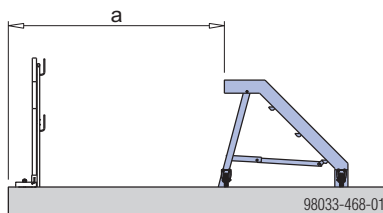

Permissible load-bearing capacity: 150 kg



Follow all country-specific regulations!

Working off working platform or working scaffold to lay sliding meshes

Sliding meshes can be laid on the secondary beams from above by an operator working off a safe work-deck level, e.g.:

- Ringlock working scaffold
- Bracket platform M
- Folding platform K



Follow the directions in the relevant User Information booklet!

Practical example with Ringlock working scaffold

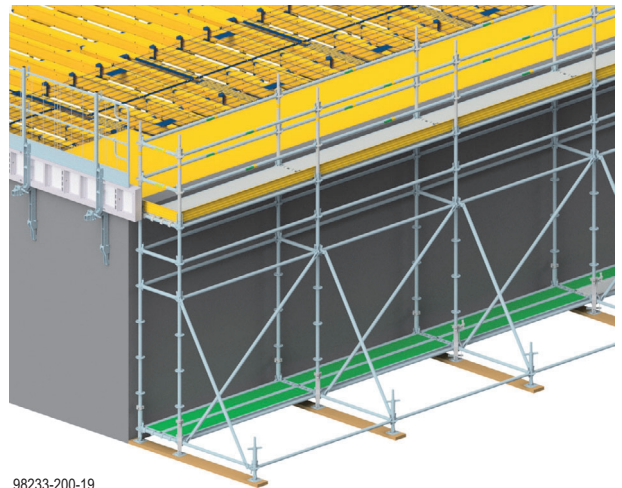

Laying formwork sheets

Laying formwork sheets in the typical zone



WARNING Falling hazard!

Before anyone steps on to the formwork:

- ▶ Ensure the stability of the formwork (e.g. with Bracing frames Eurex, with bracing or with tie-backs). See the 'Dokaflex' or 'Safeflex' User Information booklet.
- ▶ Install all-round fall protection, e.g. using Xsafe edge protection XP, Bracket platform M or façade scaffold!
- ▶ Lay sliding meshes and the first row of sheets across the entire width of the room! Only when this has been done is the safe distance (>2.00 m) from the drop edge ensured.

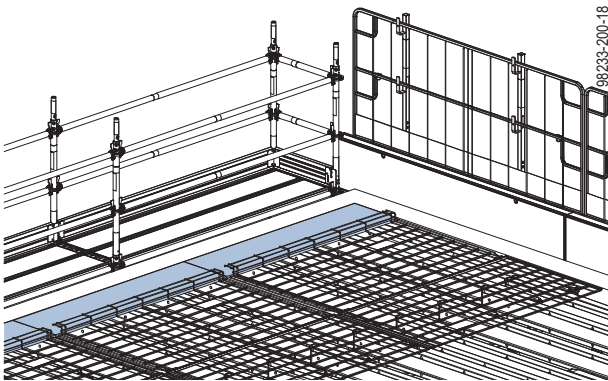

WARNING

- ▶ It is not permitted to set down loads on the floor formwork (e.g. beams, formwork sheets, reinforcement steel) until after the intermediate props have been set up and adequate stability has been established!
- ▶ Transfer of horizontal loads during pouring must be ensured by other measures (e.g. by transferring these loads into the structure or using tie-backs). See the 'Dokaflex' or 'Safeflex' User Information booklet.



WARNING Falling hazard!

If two or more formwork sheets are laid one in front of the other and the sliding mesh is slid forward each time, the minimum safe distance of 2.00 m from the drop edge is not maintained.

- ▶ Lay formwork sheets row by row in the direction of the secondary beams.
- ▶ Slide the sliding mesh of each sheet line in turn forward by max. one formwork sheet width.

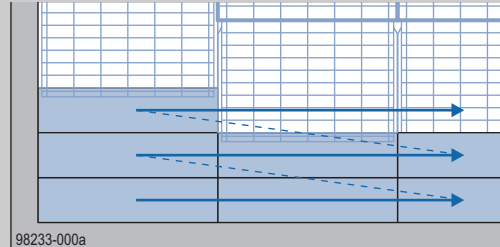

- ▶ Slide the formwork sheet under the upturn of the sliding mesh.

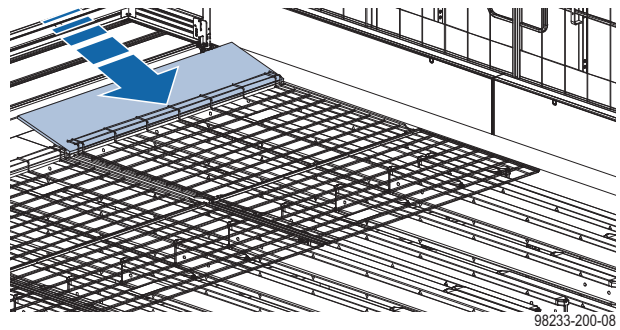

- ▶ Slide the formwork sheet and the sliding mesh forward.

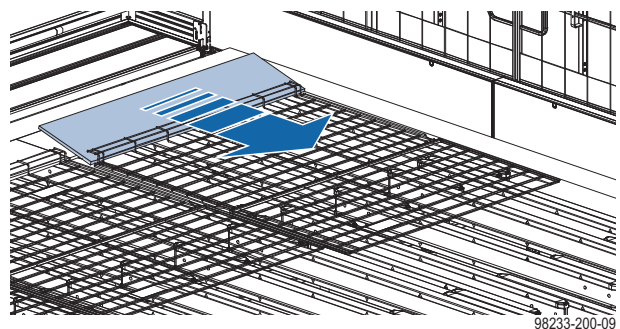

- ▶ Lay the formwork sheet flat.

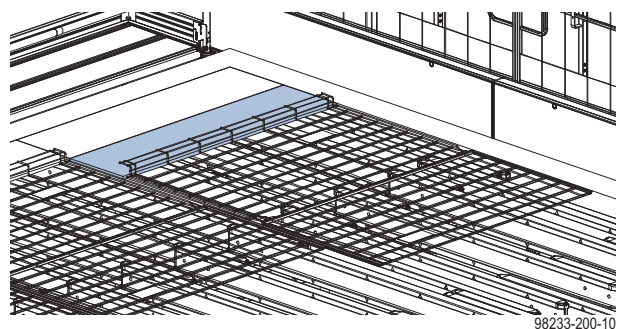

- ▶ Continue installing formwork sheets in the same way.

Laying formwork sheets in the closure zone

The use cases below are described in detail in the corresponding sections of the same name:

- Usage situation 1: [Closure zone in sliding direction](#)
- Usage situation 2: [Closure zone transverse to sliding direction](#)



NOTICE

- Width of the closure zone ≤ 30 cm:
No sliding mesh required.
- Width of the closure zone > 30 cm:
sliding mesh or fall arrester, e.g. FreeFalcon, required.

All the schematic illustrations below are depicted without supporting structure (floor props, primary beams, secondary beams).

Closure zone in sliding direction

- Lay formwork sheets under the sliding mesh as far as the mesh hinge.

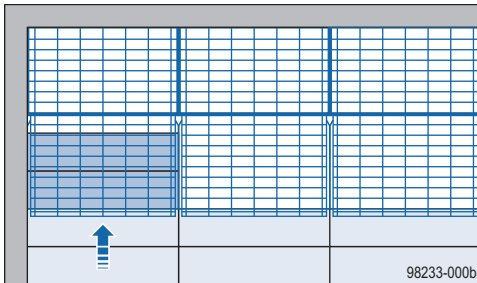

- Fold the sliding mesh closed and slide it back as far as the formwork sheet.

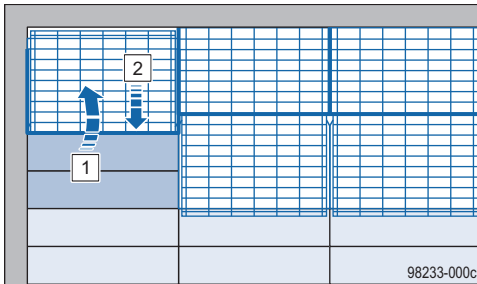

- Repeat these steps for the remaining sheet lines.

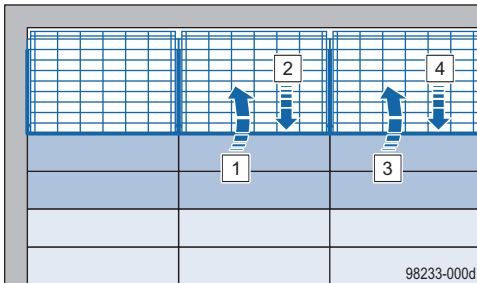

- Continue laying formwork sheets in each sheet line to the end of the room under closed sliding meshes and slide the sliding meshes forward as necessary to the end of the room.

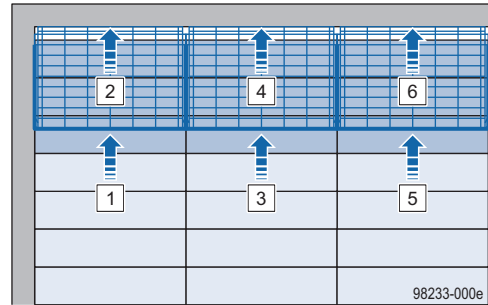

- Lay infill sheets.

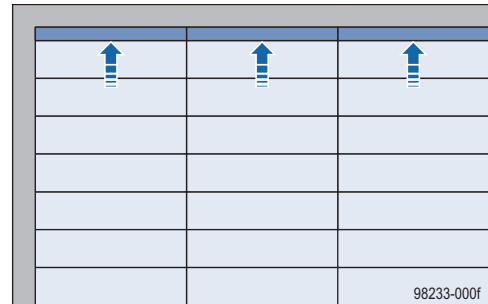

Closure zone transverse to sliding direction

- Lay overlapping sliding meshes in the closure zone.

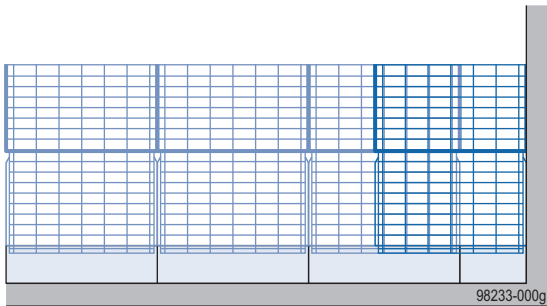

- Lift both sliding meshes at one side and lay formwork sheet and infill sheet underneath the sliding meshes.

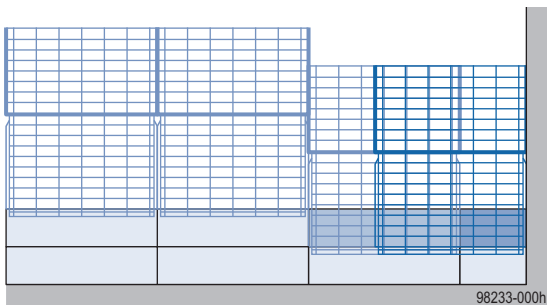

- Slide the overlapping sliding meshes forward.

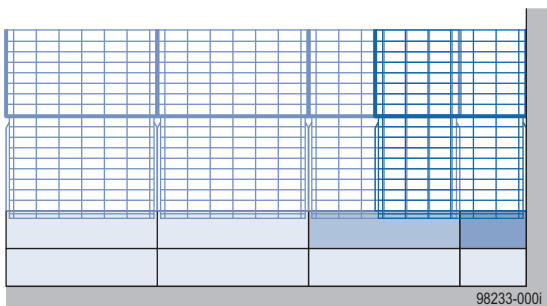

- Continue laying formwork sheets and infill sheets in the closure zone in the same way.

Laying formwork sheets at obstacles

Sliding meshes can also be used at obstacles, e.g. at structural columns, intermediate walls or wall returns.

The variants below are described in detail in the corresponding sections of the same name:

- Variant 1: [Skipping past obstacle](#)
- Variant 2: [Bypassing obstacle on one side](#)



WARNING

Falling hazard!

- Max. 30 cm centre-to-centre spacing (**x**) between the secondary beams for openings (**A**) at obstacles that cannot be covered by the sliding mesh.



WARNING

Risk of tipping over!

- In the area (**A**) of obstacles, additionally secure secondary beams against overturn, e.g. with the Secondary-beam stabilisers 1 and 2 or with the Connector clip H20 (see the 'Dokaflex' or 'Safeflex' User Information booklet).

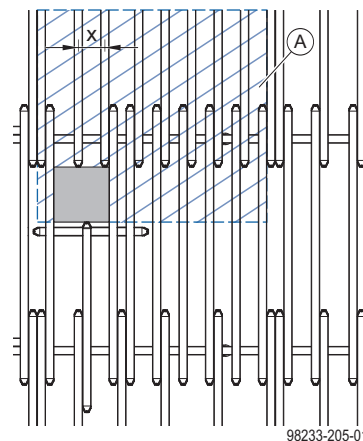

x ... max. 30 cm

A Area for additional measures

All the schematic illustrations below are depicted without supporting structure (floor props, primary beams, secondary beams).

Skipping past obstacle

- In the area of the obstacle, lay formwork sheets under sliding mesh as far as the mesh hinge.

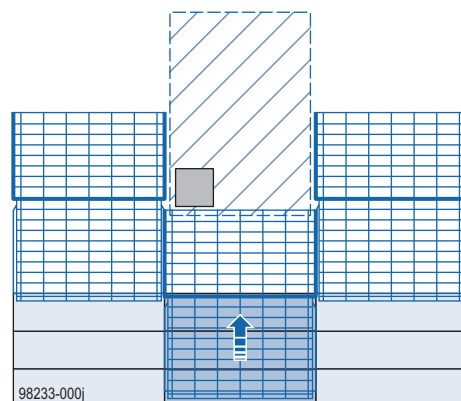

- ▶ Fold the sliding mesh closed and, if necessary, slide it forward as far as the obstacle.

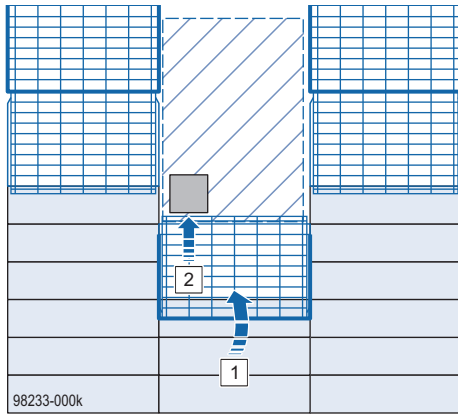

- ▶ Continue laying formwork sheets under the sliding mesh up to the obstacle.

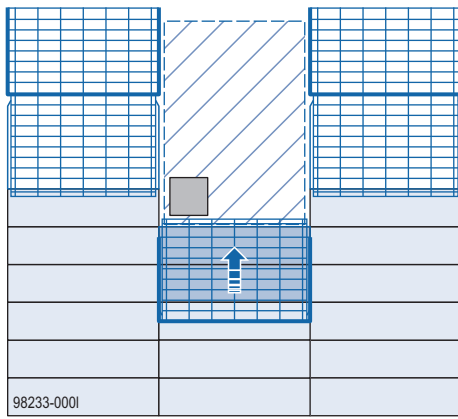

- ▶ Reposition the sliding mesh on the opposite side of the obstacle and lay infill sheets round the obstacle.

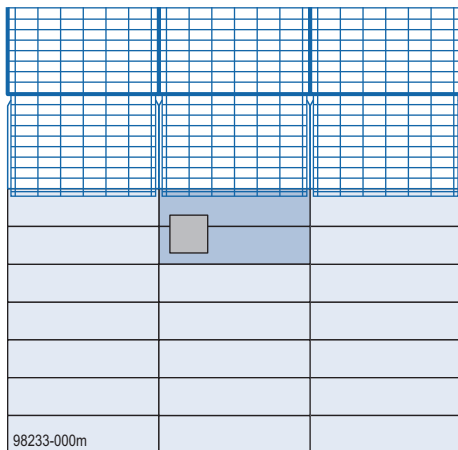

Bypassing obstacle on one side

- ▶ In the area of the obstacle, lay formwork sheets under sliding mesh as far as the mesh hinge and, if necessary, slide the sliding meshes forward as far as the obstacle.

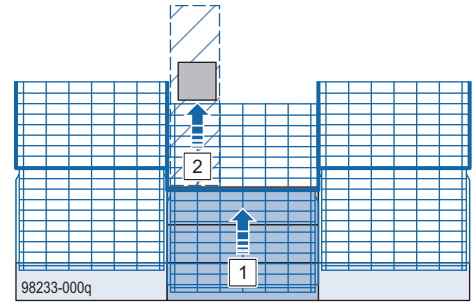

- ▶ Slide a sliding mesh forward on one side past the obstacle so that it overlaps the neighbouring sliding mesh.

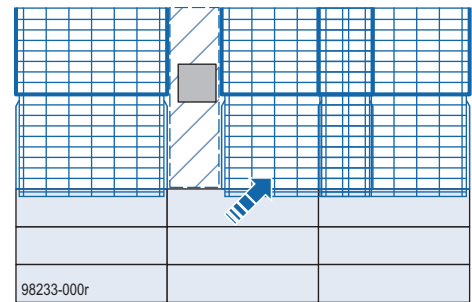

- ▶ Continue laying formwork sheets and infill sheets under the sliding mesh.

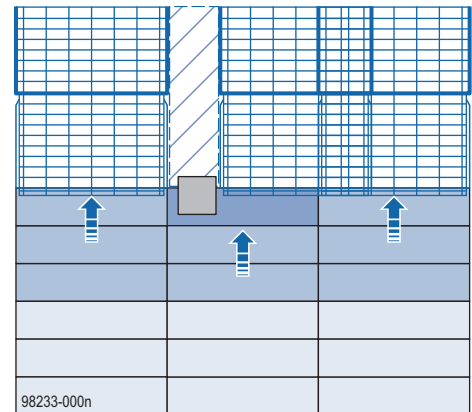

- ▶ Past the obstacle, again position the sliding mesh on the original sheet line.

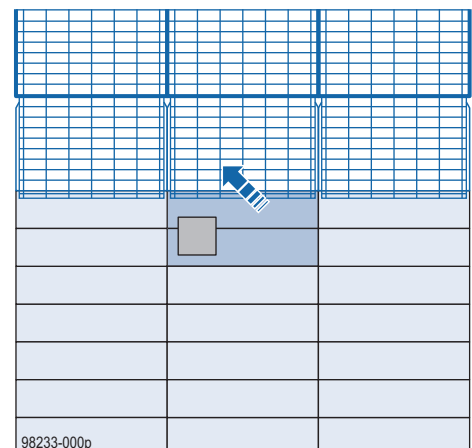

Technical condition

The following quality criteria define the statically permitted degree of damage or weakening.

Use is prohibited if the damage is more extensive.

- Only continuous mesh bars permitted. Broken mesh bars and cut-through mesh bars prohibited!

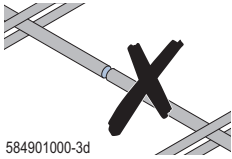

- Deflection (**x**) of the mesh bars: max. 2 cm

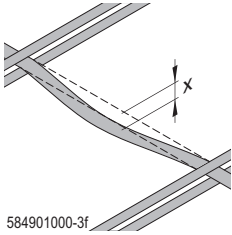

- Mesh bars must be welded to the guide rails (**A**) and in all 3 hinge areas to the shaped tube (**B**).

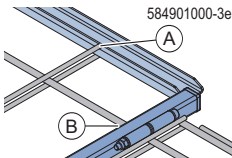

- Both guide wires (**C**) of the front mesh half must be welded to the mesh and must be free of bends.

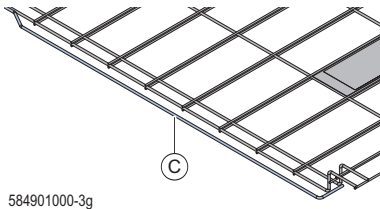

- Max. 5 faulty weld spots per mesh half permitted. Faulty weld spots directly next to each other are not permitted.

Transporting, stacking and storing

Doka stacking pallet 2.00x1.70m

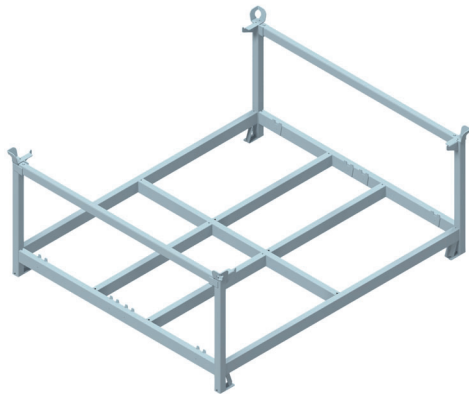

- Storage and transport device for max. 15 Safeflex sliding meshes 2.00m or 2.50m.
- Removable cross-bars to protect the Safeflex sliding meshes 2.00m when lashing them to the truck.
- Integrated position holders for precise and non-slip loading of the bottom Safeflex sliding mesh.
- The [Universal castor wheel for transport pallet](#) turns multi-trip packaging items into fast and manoeuvrable transport devices.

Permissible load-bearing capacity: 475 kg (1050 lbs)
 Permitted imposed stacking load: 2800 kg (6200 lbs)

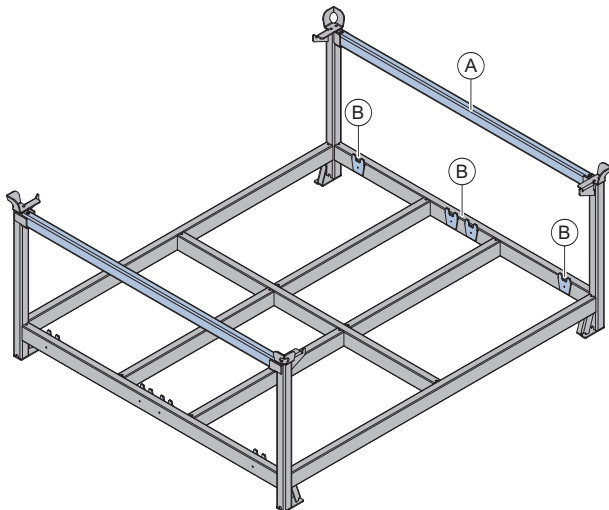

- A** Cross-bar
- B** Position holder

Loading the stacking pallet



The two cross-bars (**A**) can be removed to facilitate loading and unloading of the sliding meshes.

Note:

Loading of Safeflex sliding meshes 2.00m and 2.50m is identical.

- ▶ Remove the cross-bars (optional) and place the first sliding mesh in the centre.

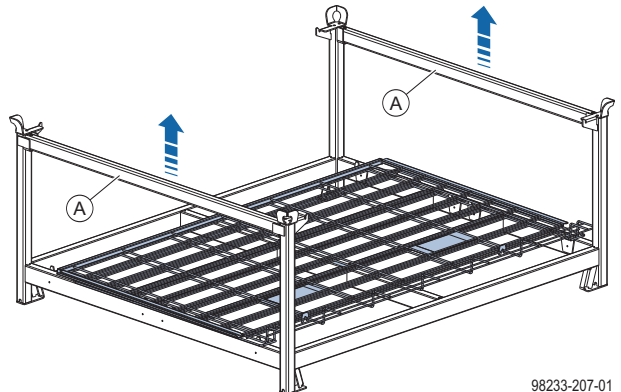

98233-207-01



- The sliding mesh rests against the vertical bar (**E**) of the stacking pallet.
- Observe the correct position of the sliding mesh in relation to the position holder (**B**) on the stacking pallet.

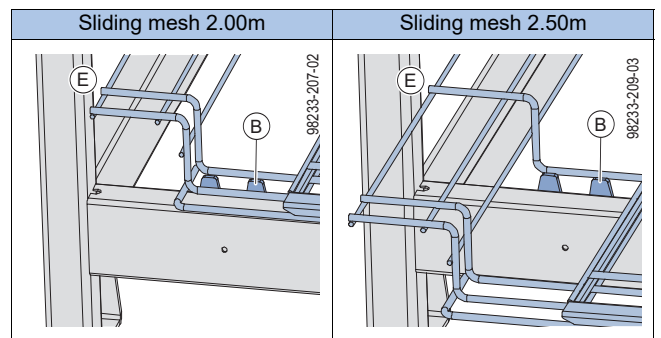

- ▶ Stack further sliding meshes at an offset to one another.

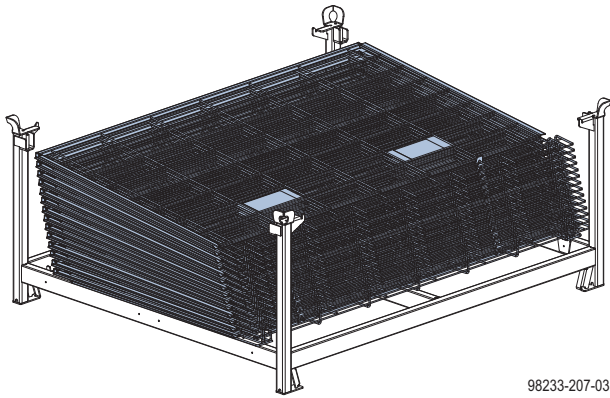

98233-207-03

Close-up of transport lock for sliding meshes (new version only)

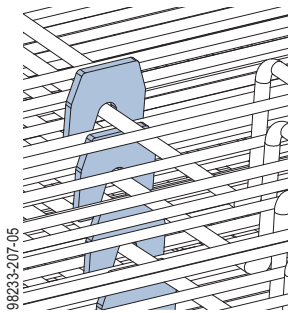

98233-207-05

- ! **NOTICE**
Meshes can be damaged during bundling or transport.
▶ Always insert a squared timber 8x10cm (C)

- ▶ Insert both cross-bars and connect the sliding meshes to the stacking pallet so that they cannot slip or tip over.

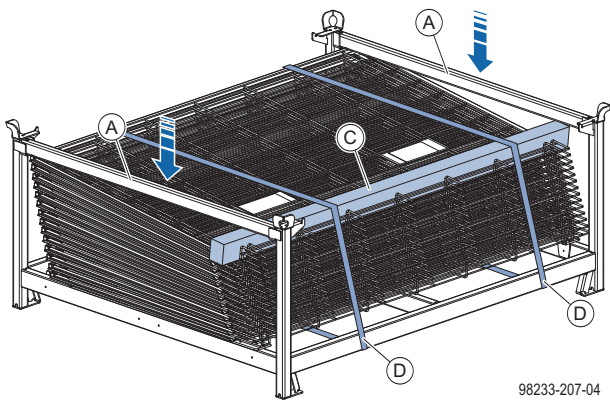

98233-207-04

- A Cross-bar
- C Squared timber 8x10cm (upright)
- D Strapping band or lashing strap

Using Doka stacking pallets as storage units

Max. number of units on top of one another

Outdoors (on the site) Floor gradients up to 3%	Indoors Floor gradients up to 1%
2	6
It is not allowed to stack empty multi-trip boxes or pallets on top of one another!	

- ! **NOTICE**
▪ Stacked multi-trip boxes or pallets must have the heaviest boxes at the bottom and the lightest at the top!

Using Doka stacking pallets as transport devices

Lifting by crane

! **WARNING**
Sliding meshes without a transport lock (old version) may slip!

- ▶ Always fasten sliding meshes without a transport lock to the stacking pallet (e.g. with strapping band or lashing strap) when repositioning, so that they cannot slip or tip over!
- ▶ This also applies to repositioning stacking pallets that carry both sliding meshes with and without transport locks.

- ! **NOTICE**
▪ Multi-trip packaging items must be lifted individually.
- Use suitable lifting chains:
 - e.g. Doka 4-part chain 3.20m
 - Do not exceed the permitted working load limit of the lifting chains.
- Load the items centrally.
- Sling angle β max. 30°!

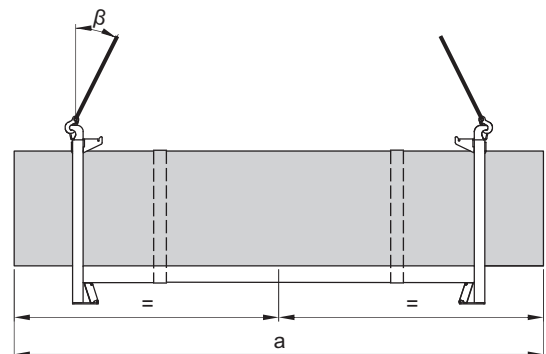

98233-209-01
a ... max. 250 cm

Repositioning by forklift truck or pallet stacking truck



NOTICE

- Load the items centrally.
- Ensure sufficient fork length of forklift trucks and pallet stacking trucks. If necessary, use fork extensions or telescopic forks.

Max. number of units on top of one another

Repositioning by forklift truck	Repositioning by pallet stacking truck
max. 3 stacking pallets	1 stacking pallet
<p>98233-210-01</p>	<p>98233-210-03</p>
<p>98233-210-02</p>	<p>98233-210-04</p>

A Cross-bar

Correct loading of trucks (lorries)



WARNING

Sliding meshes - whether with or without a transport lock - may slip!

- ▶ Before loading the truck, always secure the sliding meshes to the stacking pallet so that they cannot slip or tip over (e.g. with strapping band or lashing strap)!



NOTICE

- Only load stacking pallets onto trucks with the cross-bars mounted.
- Arrange the stacking pallets with Sliding meshes **2.00m at right angles to the cargo floor. (A)**

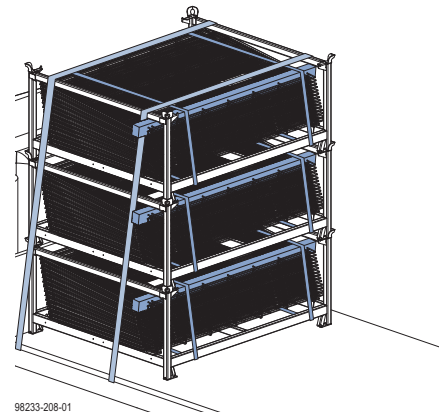

- Arrange the stacking pallets with Sliding meshes **2.50m lengthways to the cargo floor. (B)**

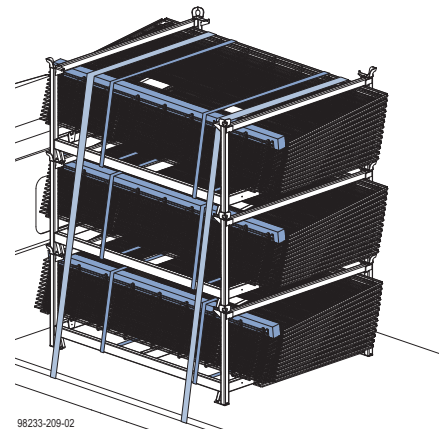

- Load the truck from front to back with stacking pallets. **(C)**
- Butt the stacking pallets tightly against each other. **(D)**
- Secure each pallet stack to the truck with 2 lashing straps. **(E)**

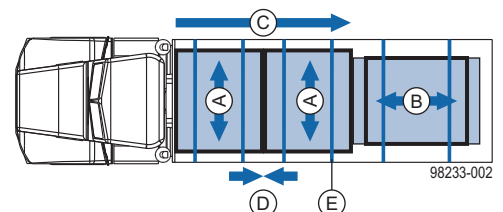

Universal castor wheel for transport pallet



The Universal castor wheel for transport pallet turns multi-trip packaging items into fast and manoeuvrable transport devices.

- 4 castor wheels needed per multi-trip packaging item.
- Compatible multi-trip packaging items:
 - Doka stacking pallets (all sizes)
 - Doka multi-trip transport box 1.20x0.80m
 - Doka skeleton transport box 1.70x0.80m
 - DokaXdek panel pallets (all sizes)
 - Superdek beam pallet 1.22x1.10m

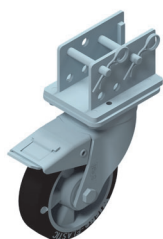

Follow the directions in the 'Universal castor wheel for transport pallet' User Information booklet.

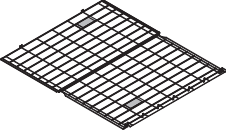

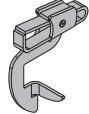
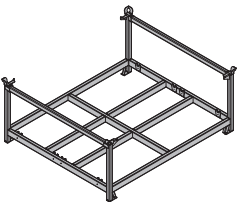
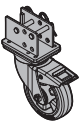
	[kg]	Article N°	[kg]	Article N°
Safeflex sliding mesh 2.00m Safeflex sliding mesh 2.50m Safeflex-Schiebegitter  Powder-coated blue Delivery condition: folded closed	22.0 26.5	584901000 584900000		
Secondary-beam stabiliser 1 Secondary-beam stabiliser 2 Querträgersicherung  Galvanised Height: 38.7 cm	1.6 2.1	586196000 586197000		
Connector clip H20 Kreuzverbinder H20  Galvanised Height: 18 cm	0.7	586184000		
Doka stacking pallet 2.00x1.70m Doka-Stapelpalette 2,00x1,70m  Galvanised Height: 77 cm	85.0	584909000		
Universal castor wheel for transport pallet Universal-Lenkrolle Transportgebände  Galvanised Height: 28.8 cm	6.0	584043000		



Formwork & Scaffolding.
We make it work.
