

# Doka loading platform 2.45x3.20m 3.0t

(8'-0"x10'-6" 6613 lbs)

## User Information

Instructions for assembly and use (Method statement)

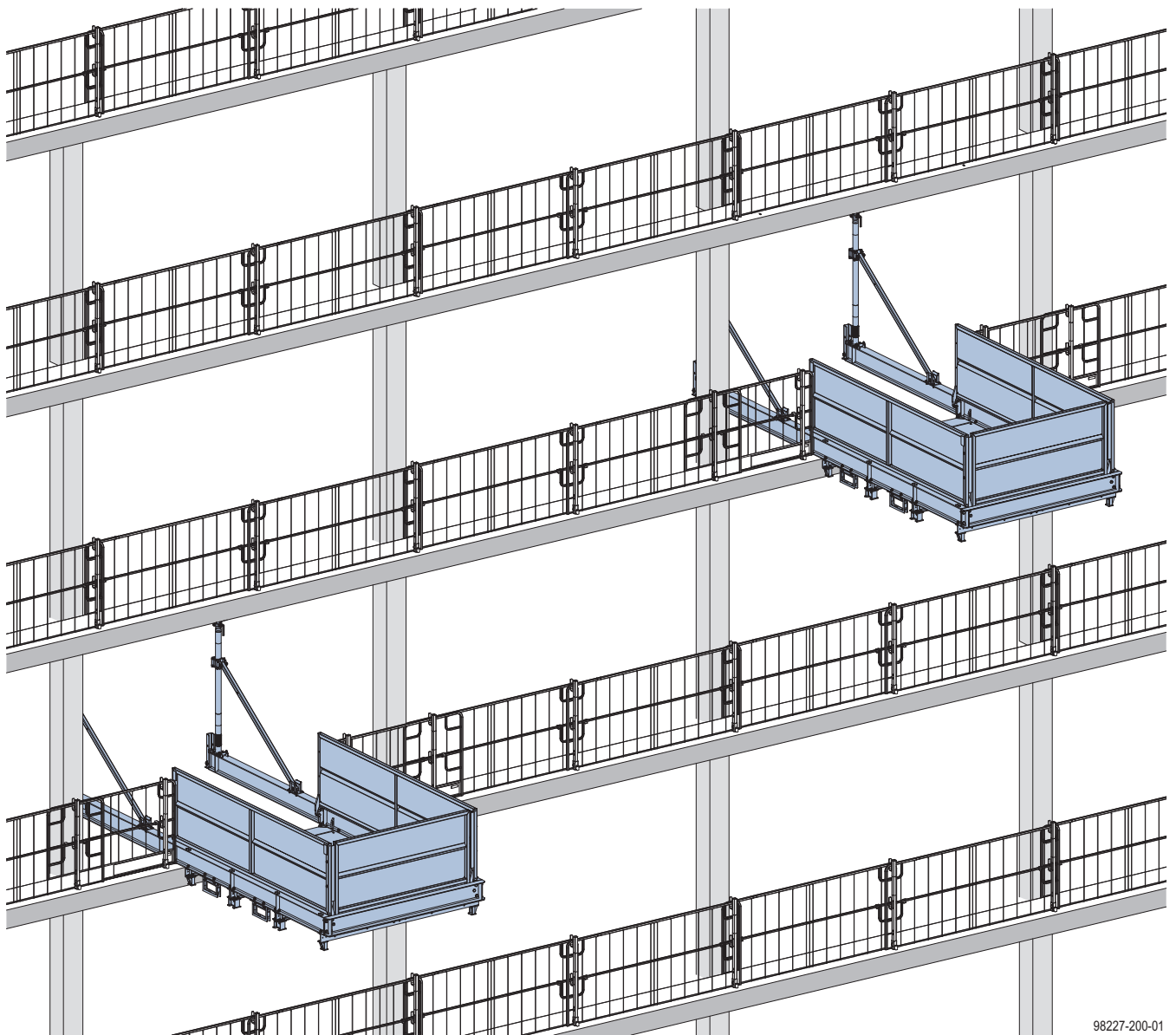

98227-200-01



# Contents

## **4 Introduction**

- 4 Elementary safety warnings
- 7 Services

## **8 System description**

- 10 Intended use
- 12 System dimensions
- 13 Fixing options

## **14 Loading data**

- 16 Imposed loads

## **17 Assembly**

- 17 Preparing the loading platform
- 22 Mounting to the structure:

## **26 Operation**

## **27 Repositioning**

## **29 General**

- 29 Additional areas of use
- 30 Transporting, stacking and storing

## **33 Checklist for inspection**

## **34 Article list**

# Introduction

## Elementary safety warnings

### User target groups

---

- This booklet is aimed at all persons who will be working with the Doka product or system that it describes. It contains information on the standard design for setting up this system, and on correct, compliant utilisation of the system.
- All persons working with the product described herein must be familiar with the contents of this booklet and with all the safety instructions it contains.
- Persons who are incapable of reading and understanding this booklet, or who can do so only with difficulty, must be instructed and trained by the customer.
- The customer is to ensure that the information materials provided by Doka (e.g. User Information booklets, Instructions for Assembly and Use, Operating Instruction manuals, plans etc.) are up to date and available to all users, and that they have been made aware of them and have easy access to them at the usage location.
- In the relevant technical documentation and form-work utilisation plans, Doka shows the workplace safety precautions that are necessary in order to use the Doka products safely in the usage situations shown.  
In all cases, users are obliged to ensure compliance with national laws, standards and regulations throughout the entire project and to take appropriate additional or alternative workplace safety precautions where necessary.

### Hazard assessment

---

- The customer is responsible for drawing up, documenting, implementing and continually updating a hazard assessment at every job-site. This booklet serves as the basis for the site-specific hazard assessment, and for the instructions given to users on how to prepare and utilise the system. It does not substitute for these, however.

### Remarks on this booklet

---

- This document can be used as general Instructions for Assembly and Use (Method Statement) or be incorporated into site-specific Instructions for Assembly and Use (Method Statement).
- **The graphics, animations and videos in this document or app sometimes depict partially assembled assemblies and may require additional safety equipment and/or measures to comply with safety regulations.**  
The customer must ensure all applicable regulations are complied with, even if they are not shown or implied in the graphics, animations and videos provided.
- **Individual sections contain further safety instructions and/or special warnings as applicable.**

### Planning

---

- Provide safe workplaces for those using the form-work (e.g. for when it is being erected/dismantled, modified or repositioned etc). It must be possible to get to and from these workplaces via safe access routes!
- **If you are considering any deviation from the details and instructions given in this booklet, or any application which goes beyond those described in the booklet, then revised static calculations must be produced for checking, as well as supplementary assembly instructions.**

### Regulations; industrial safety

---

- All laws, Standards, industrial safety regulations and other safety rules applying to the utilisation of our products in the country and/or region in which you are operating must be observed at all times.
- If a person or object falls against, or into, the side-guard component and/or any of its accessories, the component affected may only continue in use after it has been inspected and passed by an expert.

## Rules applying during all phases of the assignment

- The customer must ensure that this product is erected and dismantled, reset and generally used for its intended purpose in accordance with the applicable laws, standards and rules, under the direction and supervision of suitably skilled persons. These persons' mental and physical capacity must not in any way be impaired by alcohol, medicines or drugs.
- Doka products are technical working appliances which are intended for industrial / commercial use only, always in accordance with the respective Doka User Information booklets or other technical documentation authored by Doka.
- The stability and load-bearing capacity of all components and units must be ensured during all phases of the construction work!
- Do not step on or apply strain to cantilevers, closures, etc. until suitable measures to ensure their stability have been correctly implemented (e.g. by tie-backs).
- Strict attention to and compliance with the functional instructions, safety instructions and load specifications are required. Non-compliance can cause accidents and severe injury (risk of fatality) and considerable damage to property.
- Sources of fire in the vicinity of the formwork are prohibited. Heaters are permissible only when used correctly and situated a correspondingly safe distance from the formwork.
- Customer must give due consideration to any and all effects of the weather on the equipment and regards both its use and storage (e.g. slippery surfaces, risk of slipping, effects of the wind, etc.) and implement appropriate precautionary measures to secure the equipment and surrounding areas and to protect workers.
- All connections must be checked at regular intervals to ensure that they are secure and in full working order.  
In particular threaded connections and wedged connections have to be checked and retightened as necessary in accordance with activity on the jobsite and especially after out-of-the-ordinary occurrences (e.g. after a storm).
- It is strictly forbidden to weld Doka products – in particular anchoring/tying components, suspension components, connector components and castings etc. – or otherwise subject them to heating.  
Welding causes serious change in the microstructure of the materials from which these components are made. This leads to a dramatic drop in the failure load, representing a very great risk to safety.  
It is permissible to cut individual tie rods to length with metal cutting discs (introduction of heat at the end of the rod only), but it is important to ensure that flying sparks do not heat and thus damage other tie rods.  
The only articles which are allowed to be welded are those for which the Doka literature expressly points out that welding is permitted.

## Assembly

- The equipment/system must be inspected by the customer before use, to ensure that it is in an acceptable condition. Steps must be taken to exclude components that are damaged, deformed, or weakened due to wear, corrosion or rot (e.g. fungal decay).
- Using our safety and formwork systems together with those of other manufacturers can create risks that may lead to injury and damage to property. This requires separate verification by the user.
- The equipment/system must be assembled and erected in accordance with the applicable laws, standards and rules by trained customer personnel whilst maintaining any applicable safety inspections that may be required.
- It is not permitted to modify Doka products; such modifications constitute a safety risk.
- Doka products and systems must be set up so that all loads acting upon them are safely transferred!

## Transporting, stacking and storing

- Observe all country-specific regulations applying to the handling of formwork and scaffolding. For system formwork the Doka slinging means stated in this booklet must be used – this is a mandatory requirement.  
If the type of sling is not specified in this document, the customer must use slinging means that are suitable for the application envisaged and that comply with the regulations.
- When lifting, always make sure that the unit to be lifted and its individual parts can absorb the forces that occur.
- Remove loose parts or secure them so that they cannot slip out of position and drop.
- When lifting formwork or formwork accessories with a crane, no persons must be carried along, e.g. on working platforms or in multi-trip packaging.
- All components must be stored safely, following all the special Doka instructions given in the relevant sections of this document!

## Maintenance

- Only original Doka components may be used as spare parts. Repairs may only be carried out by the manufacturer or authorised facilities.

## Miscellaneous

The weights as stated are averages for new material; actual weights can differ, depending on material tolerances. Dirt accretions, moisture saturation, etc. can also affect weight.

We reserve the right to make alterations in the interests of technical progress.

## Eurocodes at Doka

**The permissible values stated in Doka documents (e.g.  $F_{perm} = 70$  kN) are not design values (e.g.  $F_{Rd} = 105$  kN), unless specified!**

- It is essential to avoid confusing permissible values with design values!
- Doka documents will continue to state the permissible values.

Allowance has been made for the following partial factors:

- $\gamma_F = 1.5$
- $\gamma_{M, timber} = 1.3$
- $\gamma_{M, steel} = 1.1$
- $k_{mod} = 0.9$

Consequently, all the design values for an EC design calculation can be determined from the permissible values.

## Symbols used

The following symbols are used in this document:



### DANGER

This is a notifier drawing attention to an extremely dangerous situation in which non-compliance with this notifier will lead to death or severe, irreversible injury.



### WARNING

This is a notifier drawing attention to a dangerous situation in which non-compliance with this notifier can lead to death or severe, irreversible injury.



### CAUTION

This is a notifier drawing attention to a dangerous situation in which non-compliance with this notifier can lead to slight, reversible injury.



### NOTICE

This is a notifier drawing attention to a situation in which non-compliance with this notifier can lead to malfunctions or damage to property.



### Instruction

Indicates that actions have to be performed by the user.



### Sight-check

Indicates that you need to do a sight-check to make sure that necessary actions have been carried out.



### Tip

Points out useful practical tips.



### Reference

Cross-references other documents.

# Services

## Support in every stage of the project

- Project success assured by products and services from a single source.
- Competent support from planning through to assembly directly on site.

### Project assistance from start to finish

Every single project is unique and calls for individualised solutions. When it comes to the forming operations, the Doka team can help you with its consulting, planning and ancillary services in the field, enabling you to carry out your project effectively, safely and reliably. Doka assists you with individual consulting services and customised training courses.

### Efficient planning for a safe project sequence

Efficient formwork solutions can only be developed economically if there is an understanding of project requirements and construction processes. This understanding is the basis of Doka engineering services.

### Optimise construction workflows with Doka

Doka offers special tools that help you in designing transparent processes. This is the way to speed up pouring processes, optimise inventories and create more efficient formwork planning processes.

### Custom formwork and on-site assembly

To complement its system formwork range, Doka offers customised formwork units. And specially trained personnel assemble load-bearing towers and formwork on site.

### Just-in-time availability

Formwork availability is a crucial factor in realising your project on time and on budget. The worldwide logistics network puts the necessary formwork quantities on site at the agreed time.

### Rental and reconditioning service

The formwork material needed for any particular project can be rented from Doka's high-performing rental park. Doka Reconditioning cleans and overhauls both client-owned equipment and Doka rental equipment.

## High performance, in all stages of the project

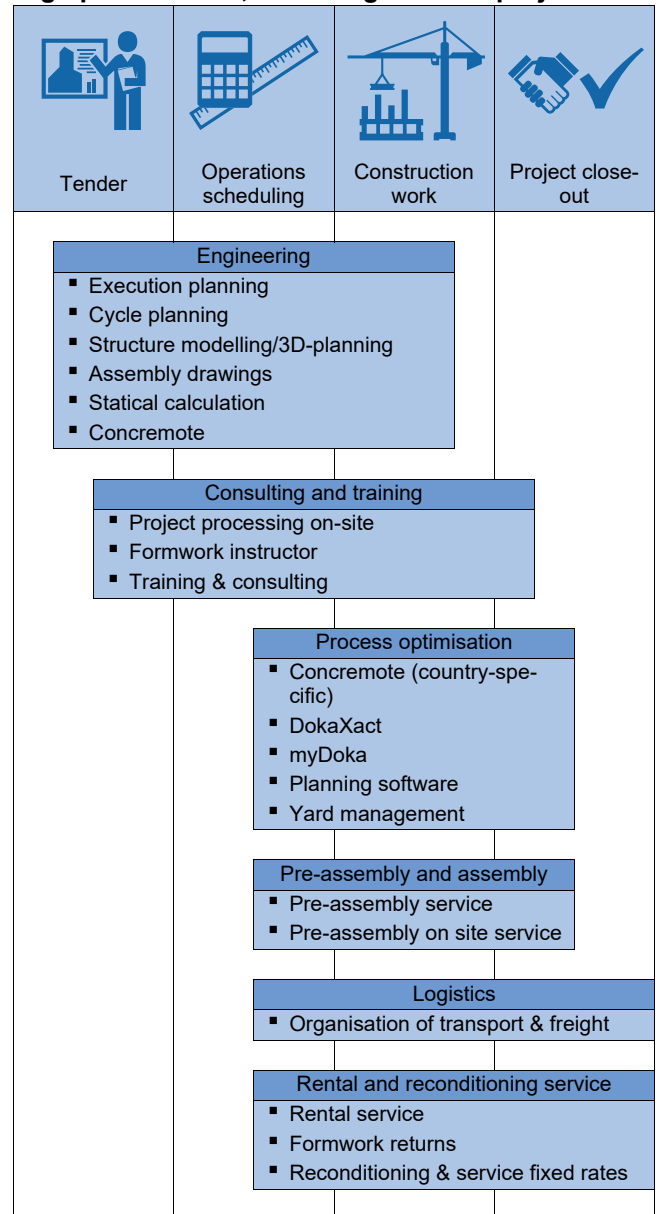

### Digital Services

for higher productivity in construction

From planning to completion of construction - with our digital services we want to set the pace for boosting productivity in construction. Our digital portfolio includes solutions for planning, procuring and managing to performing on site. Learn more about our digital offer at [doka.com/digital](https://doka.com/digital).

# System description

The Doka loading platform is where crane-lifted loads can be set down temporarily and safely outside the building. Optimised for Doka formwork and scaffolding material, the loading platform can also be used as a set-down area for building materials and construction equipment.

## Safety

### Safe working at any structure height

- Railing all round is fully closed for a high level of safety.
- Safe foot traffic, platform decking is anti-slip galvanised chequer plate.
- No gap between edge of structure and loading platform, because the platform decking rests on the structure slab.
- Safe horizontal and vertical repositioning due to integral crane lifting points and forklift pockets.

## Universality

### Suitable for various construction jobs and structure geometries

- Ideal for highrise construction – from new builds through reconstruction to building demolition.
- Free positioning at the edge of the structure, because the loading platform is clamped in place between the slabs - anchoring through the slab is an alternative
- Usable on round structures with radius 7 m (23'-0") or larger.

## Efficiency

### Improved materials logistics on the site

- Easy access from outside by crane for materials handling on all storeys.
- Reduction in crane times if loading platforms are installed on several storeys.
- Loading platform arrives pre-assembled on site – just swing the side railings and the floor props into position and pin them in place.
- As a complete unit, it repositions quickly in a single crane lift.

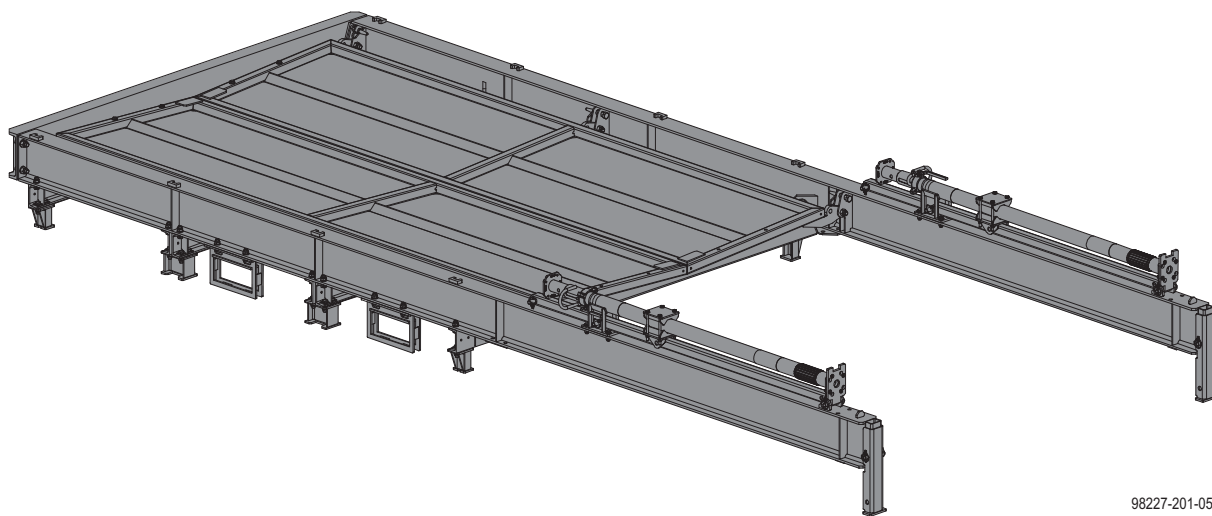

98227-201-05



## System overview

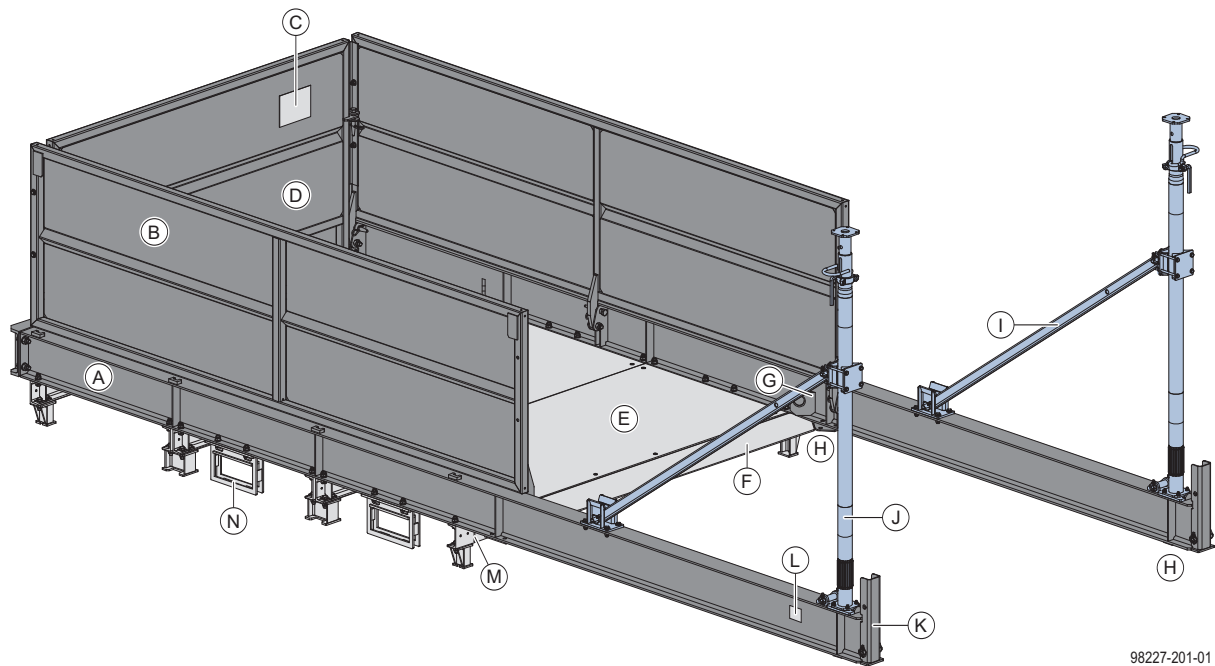

98227-201-01

A	Main beam
B	Side railing
C	Adhesive label with loading data
D	End railing
E	Platform decking
F	Loading ramp
G	Crane lifting point and marking sticker
H	Support plates for load introduction (blue marks)
I	Diagonal brace
J	Doka floor prop Eurex 20 top 350
K	Transport support
L	Type plate
M	End cross-beam
N	Forklift pockets

### Data on type plate

- Art.n°.: 586391000
- Designation: Doka loading platform 2.45x3.20m 3.0t (8'-0"x10'-6" 6613 lbs)
- Sling angle  $\beta$ :  $\leq 30^\circ$
- Dead weight: 1580 kg (3483 lbs)
- Max. load-bearing capacity: 3000 kg (6613 lbs)
- Year of manufacture: see type plate
- Serial n°: see type plate
- QR code: Information on basis of serial numbers on

### Adhesive label with loading data

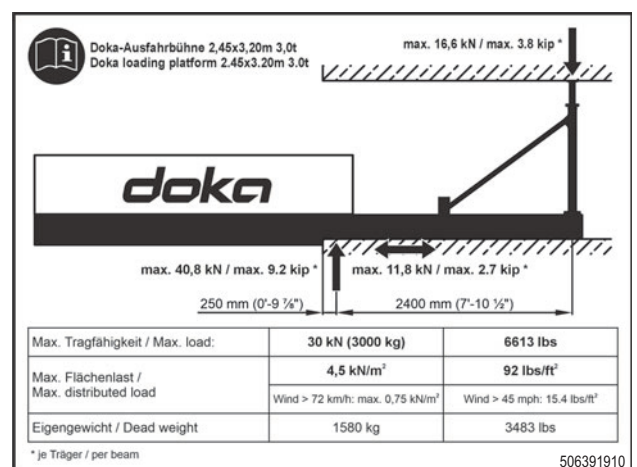

#### Note:

In addition to the loading data on the adhesive label, also follow the directions in the section headed '[Loading data](#)'!

## Intended use

The Doka loading platform is where crane-lifted loads can be set down temporarily and safely outside the building. Optimised for Doka formwork and scaffolding material, the loading platform can also be used as a set-down area for building materials and construction equipment.

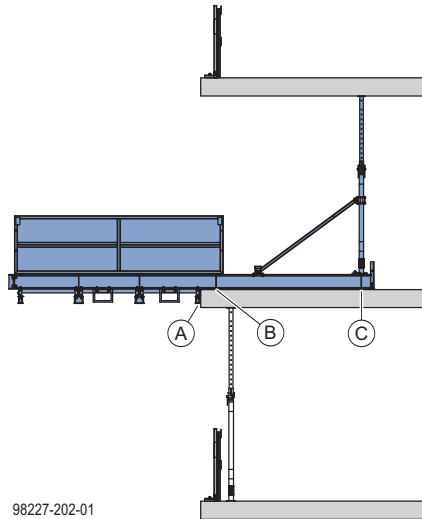

98227-202-01

- A End cross-beam
- B Support plate front
- C Support plate rear



### NOTICE

- Other use or use not in conformity with that stated above is non-intended use and requires the prior written approval of the Doka company!

## Preconditions for use:



### NOTICE

- Use the loading platform installed only on horizontal structural members of sufficient load-bearing capacity.
- Install the loading platform only at slab edges with radius  $> 7\text{ m}$  (23'-0").

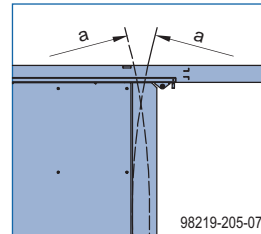

a ... radius of slab edge radius  $> 7\text{ m}$  (23'-0")



### NOTICE

- The loading platform may be certified for taking the weight of material only when it has been fully secured to the structure (see the section headed [Fixing options](#)).
- The support plates must be in full-surface contact with the slab. They are indicated by blue marks on the main beam.
- The end cross-beam of the loading platform must be seated tight against the slab edge.



### WARNING

**Risk of the loading platform falling in storm-force winds!**

- Remove the loading platform from the building if wind speeds in excess of 164 km/h (102 mph) are to be expected.

## Possible incorrect usages



### NOTICE

It is forbidden to position additional floor props on the main beam.

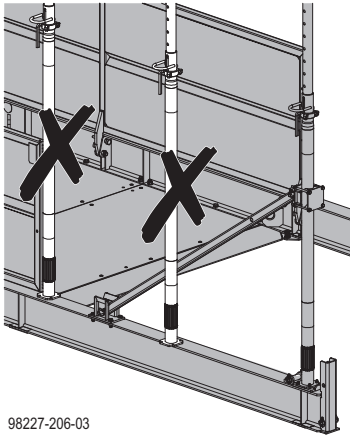

98227-206-03

## Non-standard support situations

The main beams of the loading platform have support plates which define the support points of the loading platform.

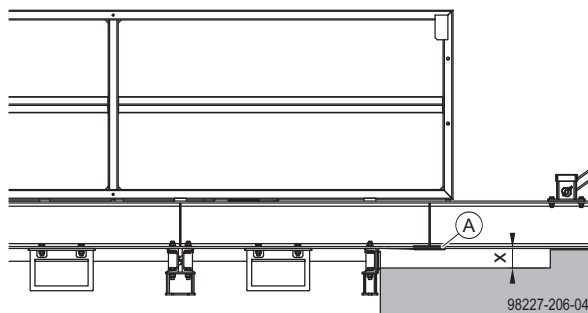

98227-206-04

x ... offset in floor-slab

A Support plate front



### WARNING

Separate static testing is required for non-standard support situations.

- Provide indication of non-standard load-bearing capacities by means of signage affixed to the loading platform.

## Maintenance & inspection

### Before every use

- Check the structure and the lifting points for damage or visible deformation.



Loading platforms and floor props that do not meet the following criteria must be withdrawn from use immediately:

- No deformation.
- No cracks or notches.
- The type plate must be in place and clearly legible.
- Adhesive labels stating loading data affixed to the railing must be clearly legible.



Use the '[Checklist for inspection](#)' for documentation.

### At regular intervals

- Inspection of loading platforms must be performed at regular intervals by an **expert** in conformity with **national statutory provisions**. Unless otherwise stipulated, such inspection must be carried out **at least once a year**.

# System dimensions

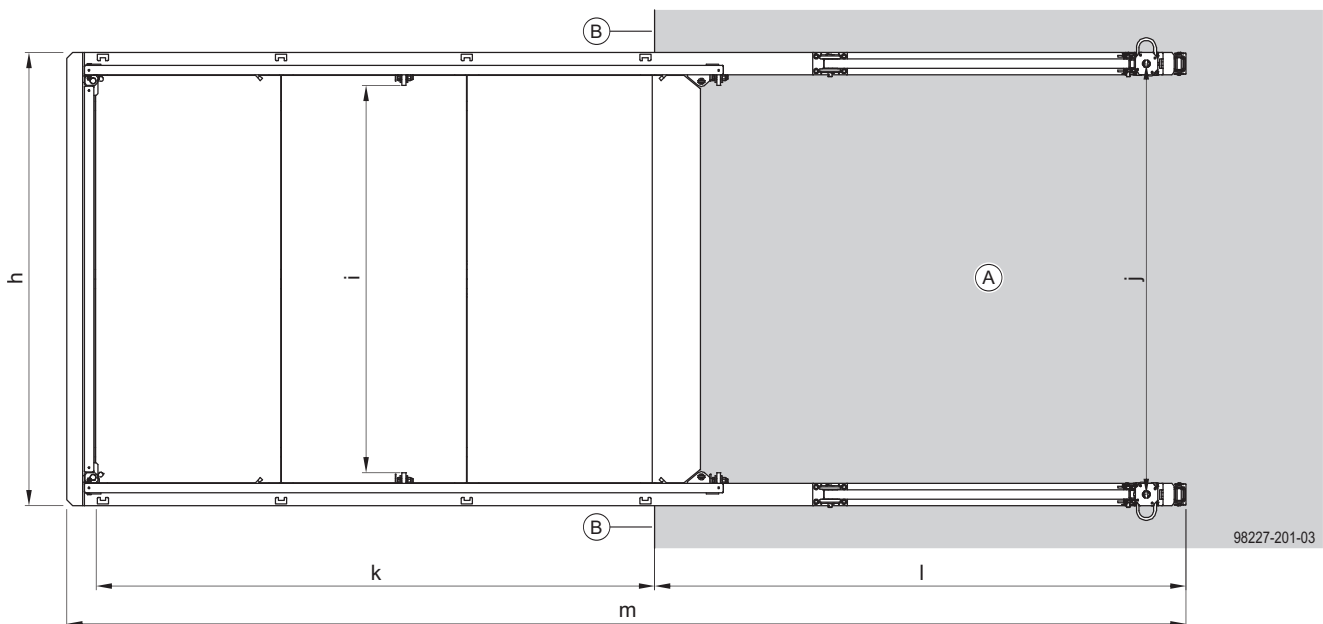
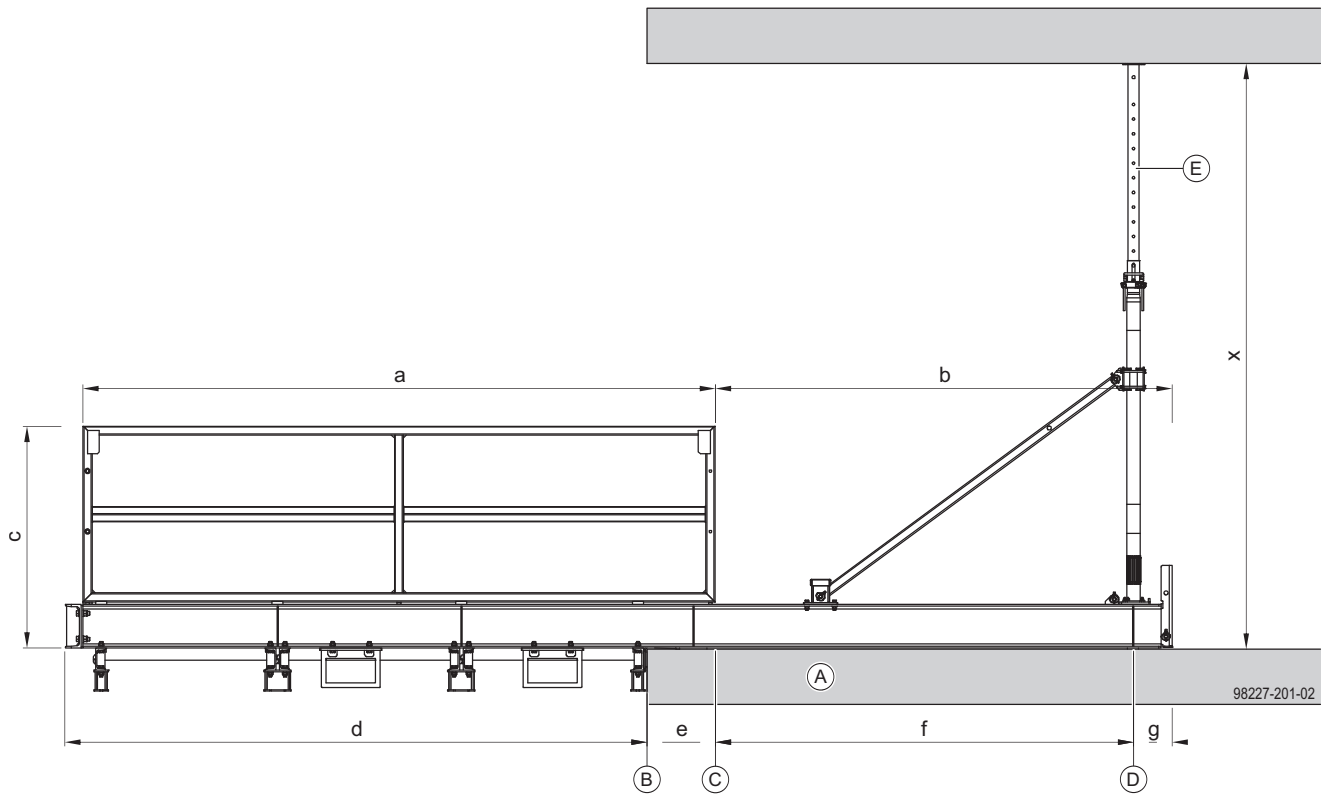

a ...	3450 mm (11'-4")	h ...	2445 mm (8'-0 1/4")
b ...	2500 mm (8'-2 1/2")	i ...	2090 mm (6'-10 1/4")
c ...	1210 mm (4'-0")	j ...	2325 mm (7'-7 1/2")
d ...	3175 mm (10'-5")	k ...	3010 mm (9'-10 1/2")
e ...	250 mm (0'-10")	l ...	2880 mm (9'-5 1/2")
f ...	2400 mm (7'-10 1/2")	m ...	6045 mm (19'-10")
g ...	215 mm (0'-8 1/2")	x ...	min. 2300mm (7'-6 1/2") - max. 3750mm (12'-3 1/2")

- A** Floor-slab
- B** Slab-edge
- C** Support plate front
- D** Support plate rear
- E** Doka floor prop Eurex 20 top 350

## Fixing options

For transfer of the vertical loads the loading platform can be clamped in place between two slabs or anchored through the slab beneath it.

### clamped in place between two slabs

The loading platform is held in place by Floor props Eurex acting upward against the slab above. Horizontal reaction loads are transferred by Doka express anchors 16x125mm.

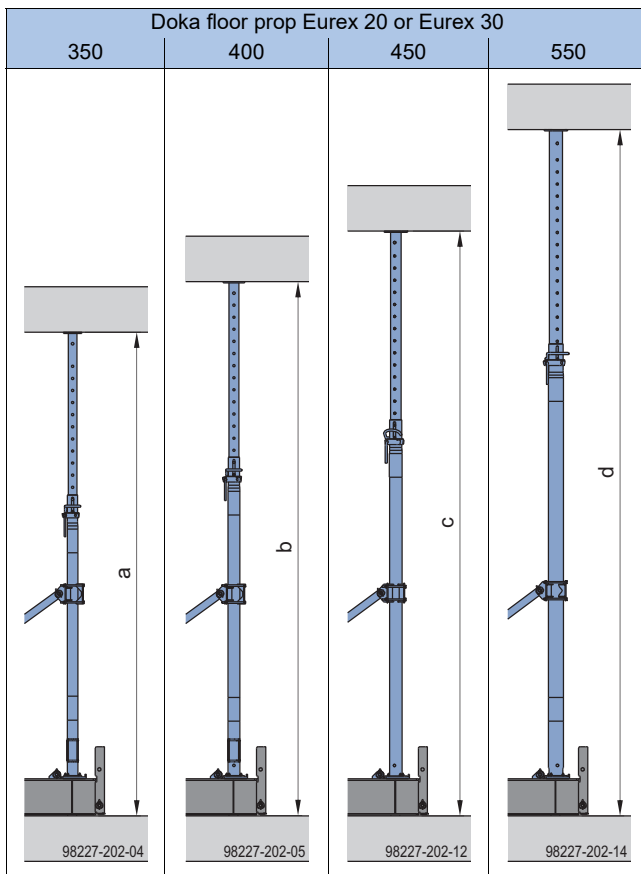

a ... min. 2300 mm (7'-6 1/2") - max. 3750 mm (12'-3 3/4")  
 b ... min. 2550 mm (8'-4 1/4") - max. 4250 mm (13'-11 1/4")  
 c ... min. 2800 mm (9'-2 1/4") - max. 4750 mm (15'-7")  
 d ... min. 3350 mm (10'-11 3/4") - max. 5750 mm (18'-10 1/2")



#### NOTICE

- Clear room heights greater than 3.75 m (12'-3 3/4") necessitate longer floor props (see the section headed '[Change of floor props for clear room height greater than 3.75 m \(12'-3 3/4"\)](#)').
- The longer floor props must be operated from a suitable working platform.

### anchored through the slab

The loading platform is anchored downward with Tie rods 20.0mm inserted into holes drilled through the slab.

Horizontal reaction loads are transferred by Doka express anchors 16x125mm.



Floor props and diagonal braces remain laid flat on the working platform.

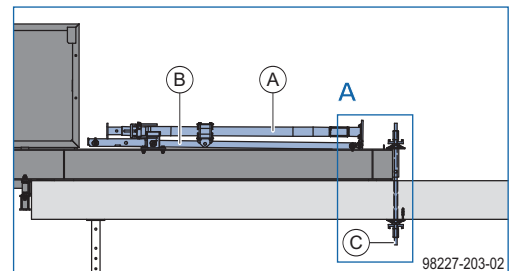

- A Doka floor prop Eurex
- B Diagonal brace 2.00m
- C Tie rod 20.0mm  
(min. length = slab thickness + 650 mm (2'-1 1/2"))

#### Close-up A

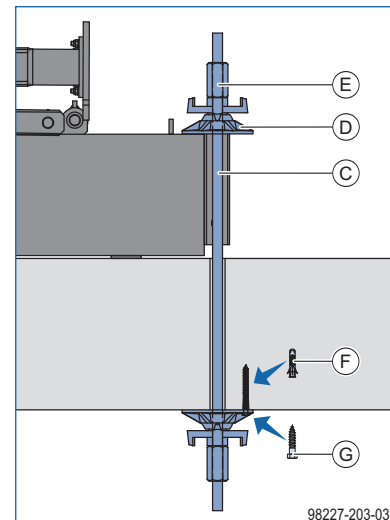

- C Tie rod 20.0mm  
(min. length = slab thickness + 650 mm (2'-1 1/2"))
- D Super plate 20.0mm
- E Hexagon nut 20.0mm
- F Dowel Ø12
- G Hexagon-head wood screw 10x80

# Loading data

## Loadability data, metric

### Evenly distributed load

Permitted load-bearing capacity: 30 kN (3000 kg)  
 Evenly distributed load: 4.5 kN/m<sup>2</sup>  
 In storm winds (>72 km/h): 0.75 kN/m<sup>2</sup>

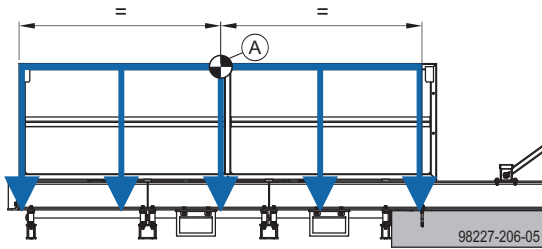

A Load centre

### Partial-area load

Permitted load-bearing capacity: 21 kN (2100 kg)  
 Min. area: 1 m<sup>2</sup>



#### NOTICE

- Make sure that the loads are evenly distributed on the main beams.
- Distance of the load centre from the edge of the platform: min. 65 cm

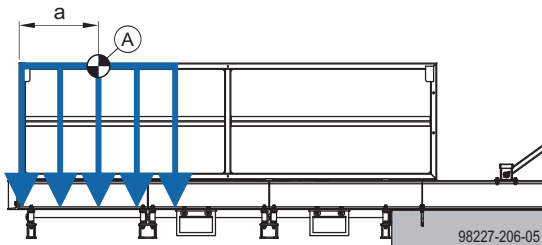

a ... min. 650 mm

A Load centre

### Local load introduction

Permitted point load (e.g. wheel load): 9 kN



#### NOTICE

- The permitted load-bearing capacity must not be exceeded by the sum of the loads set down on the platform.

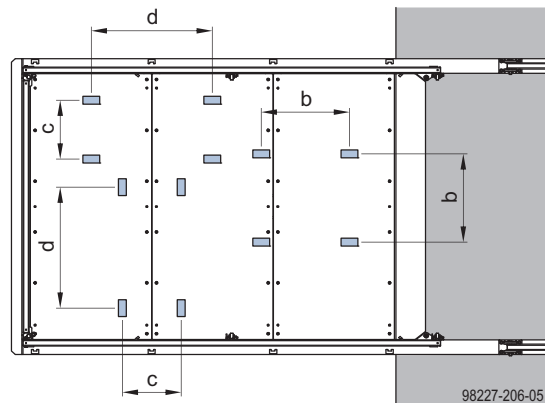

b ... 750 mm  
 c ... 500 mm  
 d ... 1000 mm

## Loadability data, imperial

### Evenly distributed load

Permitted load-bearing capacity: 6613 lbs  
 Evenly distributed load: 92 lbs/ft<sup>2</sup>  
 In storm winds (>45 mph): 15.4 lbs/ft<sup>2</sup>

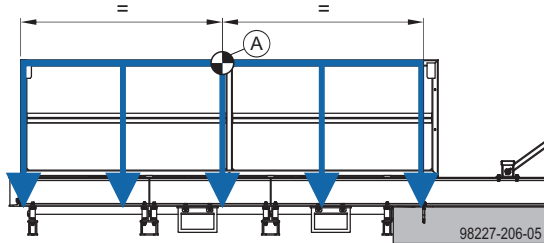

A Load centre

### Partial-area load

Permitted load-bearing capacity: 4620 lbs  
 Min. area: 10.8 ft<sup>2</sup>



#### NOTICE

- Make sure that the loads are evenly distributed on the main beams.
- Distance of the load centre from the edge of the platform: min. 2' 1 3/4"

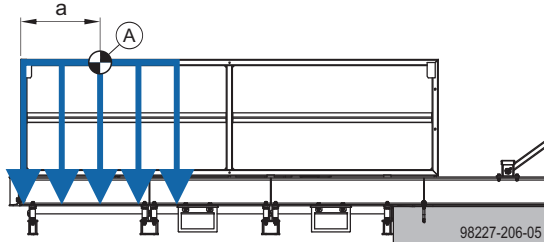

a ... min. 2' 1 3/4"

A Load centre

### Local load introduction

Permitted point load (e.g. wheel load): 1980 lbs



#### NOTICE

- The permitted load-bearing capacity must not be exceeded by the sum of the loads set down on the platform.

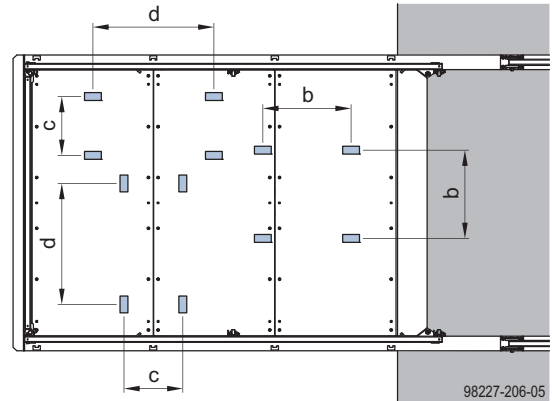

b ... 2' 6"  
 c ... 1' 8"  
 d ... 3' 3"

## Imposed loads

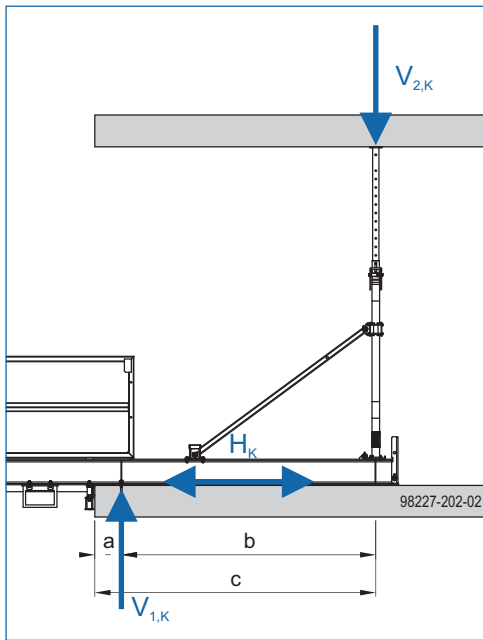

- a ... 250 mm (0'-10")  
 b ... 2400 mm (7'-10 1/2")  
 c ... 2650 mm (8'-8 1/4")

### Max. reaction loads per main beam:

Loading	0	3000 kg (6613 lbf)
Vertical load $V_{1,K}$	16.5 kN (3.7 kip)	40.8 kN (9.2 kip)
Vertical load $V_{2,K}$	5.8 kN (1.3 kip)	16.6 kN (3.8 kip)
Horizontal load $H_K$	11.8 kN (2.7 kip)	



### NOTICE

Use reaction loads in the same way for the ['anchored through the slab'](#) fixing option.

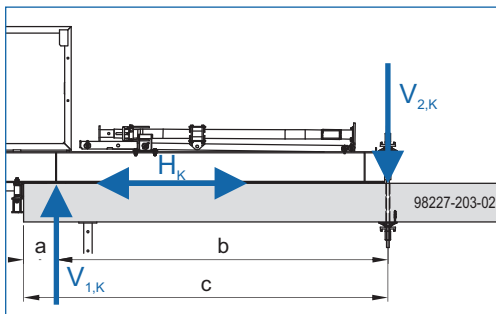

- a ... 250 mm (0'-10")  
 b ... 2580 mm (8'-5 1/2")  
 c ... 2830 mm (9'-3 1/2")

## Anchorage, horizontal loads



### WARNING

#### Risk of loading platform falling!

- Secure the loading platform with one Doka express anchor in each of the two front support plates.

With both fixing options, the Doka express anchors are absolutely essential for transfer of the horizontal loads.

### Drilling pattern for Doka express anchors

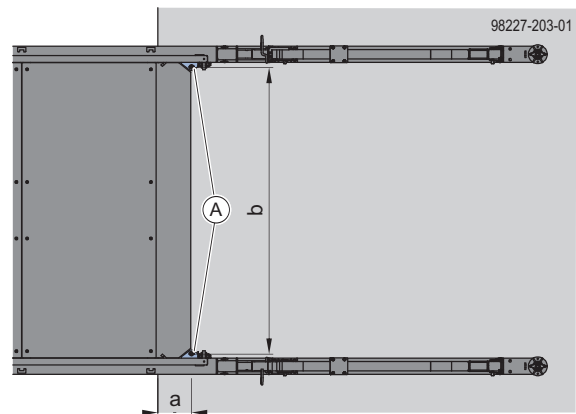

- a ... 250 mm (0'-10")  
 b ... 2140 mm (7'-0 1/4")

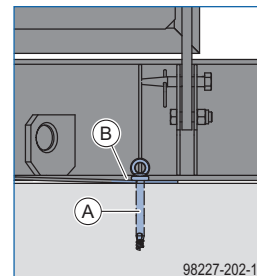

A Doka express anchor 16x125mm

B Support plate front



Follow the directions in the 'Doka express anchor 16x125mm' User Information booklet!



# Assembly

## Preparing the loading platform

### Lifting loading platform from stack

Using a crane or a forklift truck, lift the loading platform off the stack and set it down on a smooth, surfaced flat area (see the section headed '[Transporting, stacking and storing](#)').

**Lifting by crane:**

- ▶ Hook the Doka 4-part chain to the four welded-on lifting points on the main beams.
- ▶ Lift the loading platform off the stack.

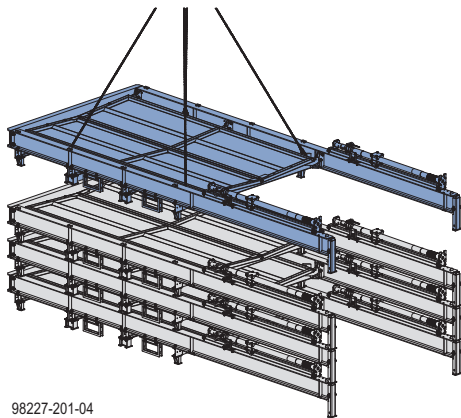

98227-201-04

- ▶ Set the loading platform down on a horizontal floor.

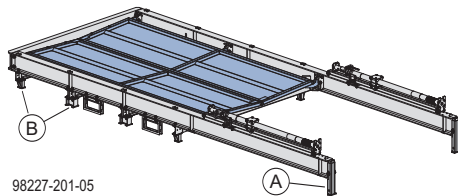

98227-201-05

- A** Transport support
- B** Height distancer

- ▶ Detach the loading platform from the crane.

### Mounting the railing

- ▶ Lift up the side railing.

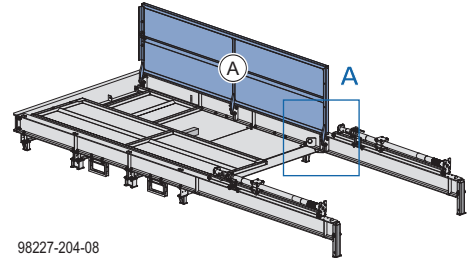

98227-204-08

- A** Side railing (52 kg (115 lbs))

- ▶ Pin the side railing to the main beam with 3 connecting pins and secure the pins.

**Close-up A**

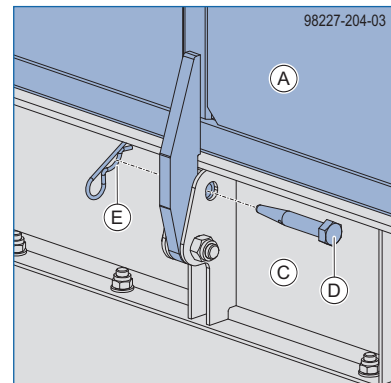

98227-204-03

- A** Side railing
- C** Main beam
- D** Connecting pin 10cm
- E** Spring cotter 5mm

- ▶ Lift up and secure the second side railing in the same way.

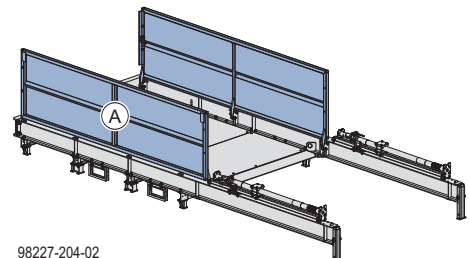

98227-204-02

- A** Side railing (52 kg (115 lbs))

- ▶ Lift up the end railing.

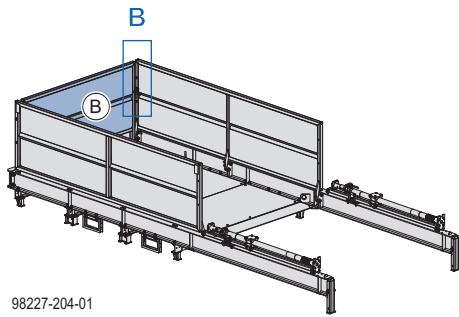

**B** End railing (48 kg (106 lbs))

- ▶ Pin the end railing to the left and right side railings and secure the pins.

**Close-up B**

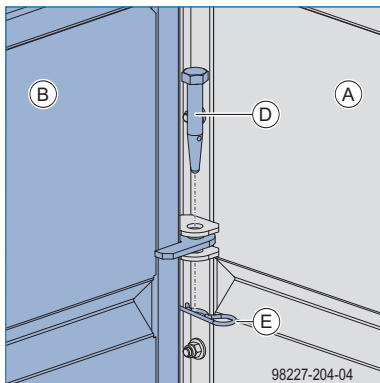

**A** Side railing  
**B** End railing  
**D** Connecting pin 10cm  
**E** Spring cotter 5mm

## Installing the floor props



**CAUTION**

- ▶ Have a helper support the floor prop during installation and removal.
- ▶ Swing the floor prop up.

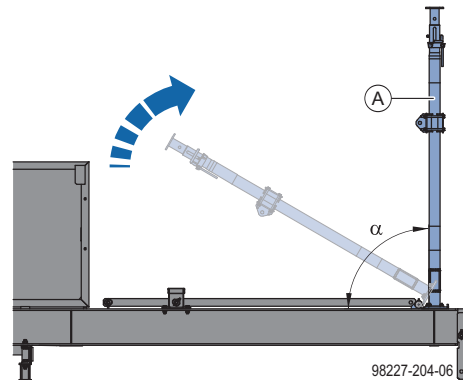

$\alpha \dots 90^\circ$

**A** Doka floor prop

- ▶ Remove the pin securing the diagonal brace from the prop support.

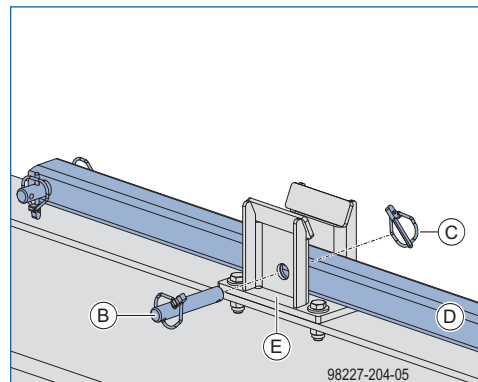

**B** Swivel bolt D20/120  
**C** Linch pin  
**D** Diagonal brace 2.00m  
**E** Prop support

- ▶ Lift the diagonal brace out of the prop support.

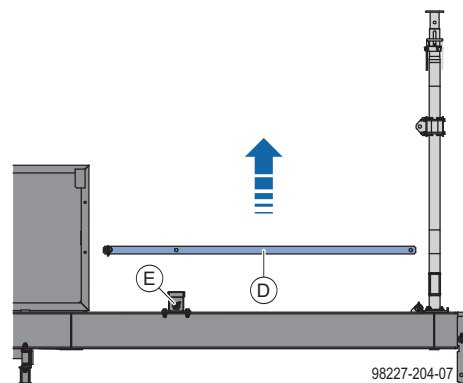

**D** Diagonal brace 2.00m  
**E** Prop support

- ▶ Pin the diagonal brace into the prop clevis on the main beam.

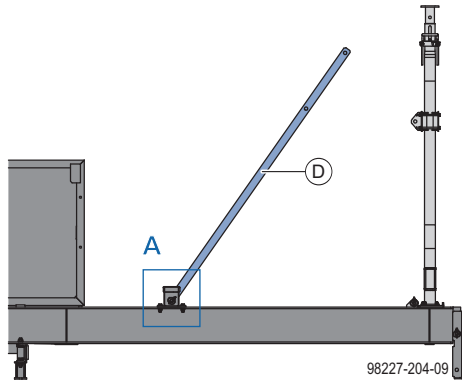

**D** Diagonal brace 2.00m

- ▶ Secure the floor prop on the second main beam in the same way.



- With the diagonal braces installed, the floor props must be vertically upright on the main beams.
- The hinge plates must be in full-surface contact with the main beams.



Use the '[Checklist for inspection](#)' for documentation.

### Close-up A

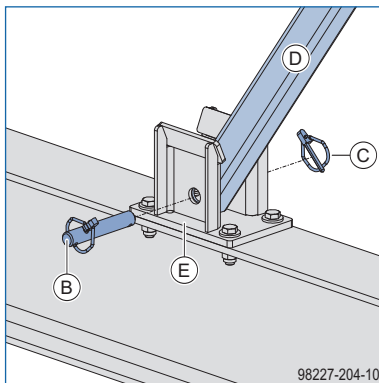

**B** Swivel bolt D20/120

**C** Linch pin

**D** Diagonal brace 2.00m

**E** Prop support

- ▶ Swing the diagonal brace into position against the floor prop.
- ▶ Pin the diagonal brace to the diagonal brace connector and secure the pin.

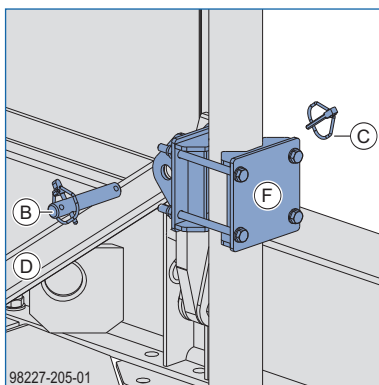

**B** Swivel bolt D20/120

**C** Linch pin

**D** Diagonal brace 2.00m

**F** Diagonal brace connector

## Change of floor props for clear room height greater than 3.75 m (12'-3 1/2")

The floor props have to be changed if clear room height is greater than 3.75 m (12'-3 1/2").

### Removing floor prop

- ▶ Lay the diagonal brace flat.
- ▶ Lay the floor prop flat.
- ▶ Remove the bolts securing the diagonal brace connector.

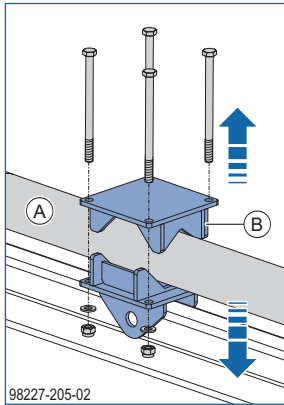

- A Doka floor prop Eurex
- B Diagonal brace connector Eurex

- ▶ Remove the diagonal brace connector.
- ▶ Remove the bolt from the hinge plate and remove the hinge plate together with the floor prop.

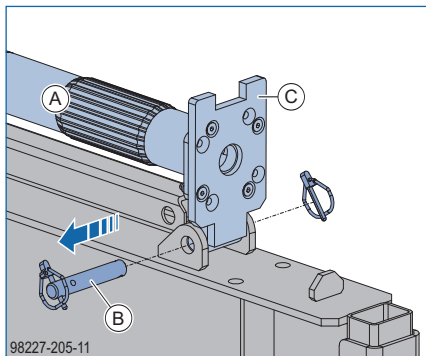

- A Doka floor prop Eurex
- B Swivel bolt D20/120 and Linch pin 6x45
- C Hinge plate for support

- ▶ Loosen and remove the bolts from the hinge plate.

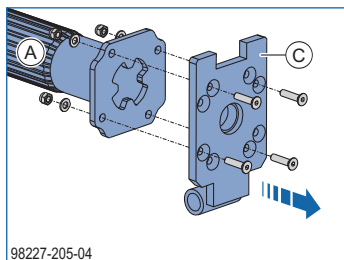

- A Doka floor prop Eurex
- C Hinge plate for support

### Installing new floor prop

- ▶ Install the hinge plate on the floor prop.

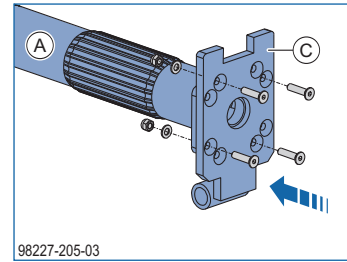

- A Doka floor prop Eurex
- C Hinge plate for support

Each loading platform is supplied with:

- 8 countersunk screws ISO 10642 M8x35 8.8
- 8 washers ISO 7089 8 200 HV-A4
- 8 hexagon nuts ISO 7040 M8 self-locking 8



The swivel bolt and the fastening clamp of the floor prop must be parallel to one another.

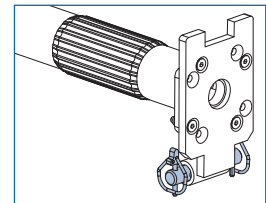
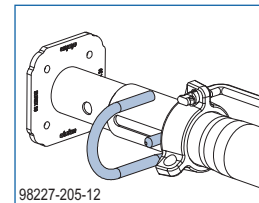

- ▶ Pin the floor prop to the main beam with the hinge plate.

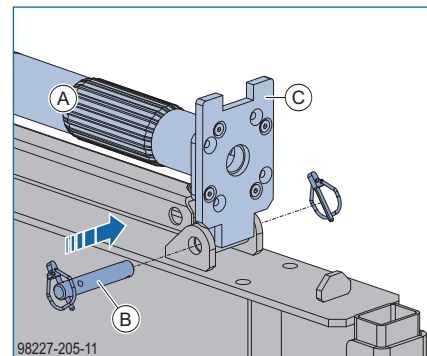

- A Doka floor prop Eurex
- B Swivel bolt D20/120 and Linch pin 6x45
- C Hinge plate for support

► Install the diagonal brace connector.

► Swing the floor prop up and secure it in the same way as a Doka floor prop Eurex 20 top 350 (see the section headed '[Installing the floor props](#)').

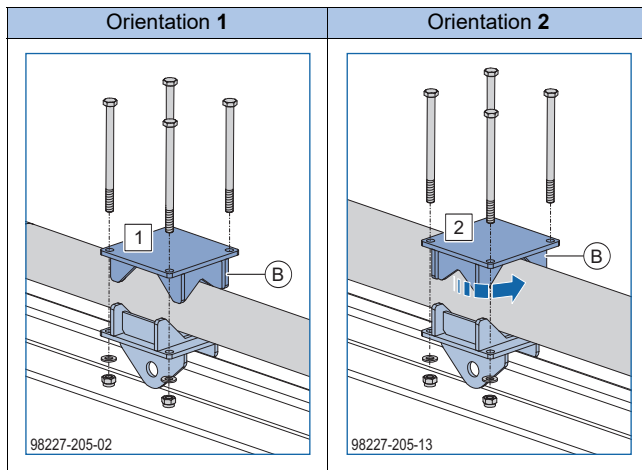

	350	400	450	550
Eurex 20 eco	-	1	1	2
Eurex 20 top	1	1	-	2
Eurex 30 eco	-	1	2	-
Eurex 30 top	-	1	2	2



Check to make sure that the clamping part is correctly positioned for the respective floor prop.

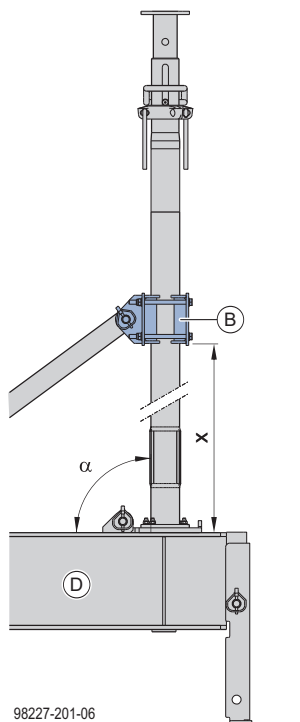

98227-201-06

$\alpha$  ... 90°

x ... 1168 mm (3'-10") distance of diagonal brace connector from main beam

**B** Diagonal brace connector Eurex

**D** Main beam

Each loading platform is supplied with:

- 8 hexagon bolts ISO 4014 M10x150 8.8
- 8 washers ISO 7089 10 St-200 HV
- 8 hexagon nuts ISO 7040 M10 self-locking 8



**NOTICE**

The self-locking hexagon nuts are not reusable.

# Mounting to the structure:

## General instructions for site-erection

### WARNING

Reposition the loading platform only when it is empty.

- ▶ The presence of material on the platform during the repositioning operation is prohibited.
- ▶ The presence of persons on the platform during the repositioning operation is prohibited.

### NOTICE

- Max. wind speed during repositioning of the loading platform: 72 km/h (45 mph).
- Be aware of the risk of collision when repositioning the loading platform (edge protection, slab edge).

- ▶ Attach a tag-line to the loading platform.
- ▶ Attach the Doka 4-part chain to the four lifting points on the loading platform.

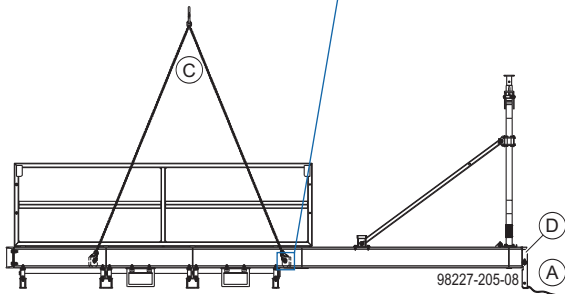
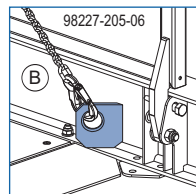

- A Tag-line
- B Crane lifting point
- C Doka 4-part chain 3.20m
- D Transport support

### NOTICE

- ▶ If the **clamped in place between two slabs** fixing option is used, install the transport support in the parked position on the main beam.
- ▶ If the **anchored through the slab** fixing option is used, install the transport support on the diagonal brace.

- ▶ Lift the loading platform off the floor.
- ▶ Remove the transport support and set it to the parked position.

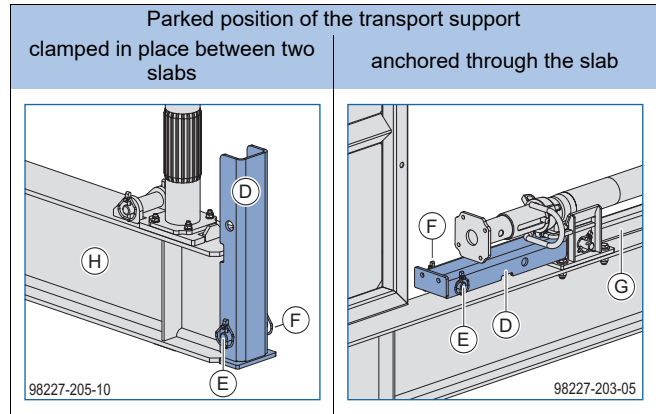

- D Transport support
- E Swivel bolt D20/120
- F Linch pin
- G Diagonal brace 2.00m
- H Main beam



If clear room height is 2.70 m (8'-10 1/4") or more the loading platform can be lifted into position with the floor props vertical. The inner tubes must be in the lowered position.



### NOTICE

**Observe the following for prop lengths over 350 cm:**

Reposition the loading platform with the floor props laid flat if the clearance between the lowered floor props and the floor-slab is 40 cm or less.

## Installing on structure with low storey height



### NOTICE

▶ If clear room height is less than 2.70 m (8'-10 1/4") the loading platform has to be lifted into position with the floor props laid flat.

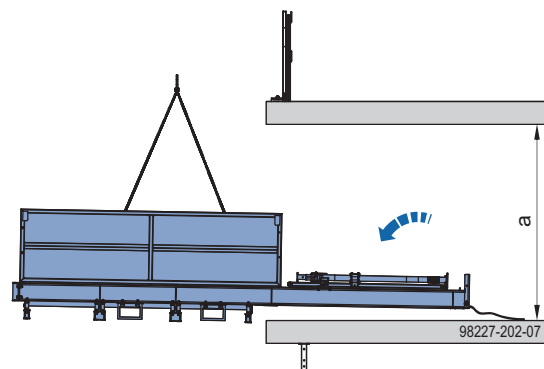

a ... clear room height < 2.70 m (8'-10 1/4")

## Fixing option - clamped in place between two slabs



### WARNING

Risk of falling at open edges!

- ▶ Use appropriate personal fall-arrest system equipment when working on unsecured slab-edges (e.g. safety harness).
- ▶ Suitable attachment points must be defined by an approved person appointed by the contractor.



### NOTICE

- ▶ Before lifting the loading platform into position, check that the slab is flat. If the slab is not flat, place suitable packing material underneath the support plates.

- ▶ Manoeuvre the lifting platform into position in the building.

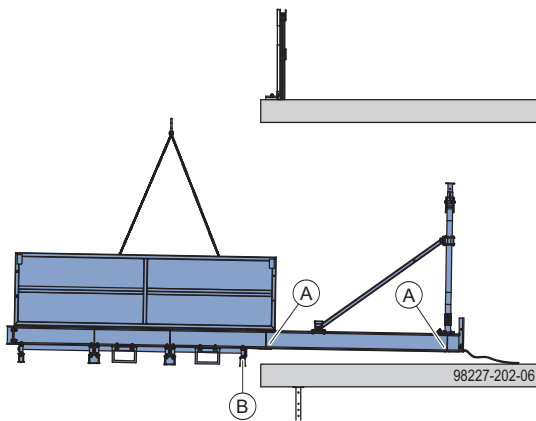

**A** Support plates for load introduction

**B** End cross-beam



### NOTICE

- The end cross-beam of the loading platform must be seated tight against the slab edge.
- The support plates must be in full-surface contact with the slab.



Marks on the main beam make the loading platform easier to position if the slab has a straight edge.

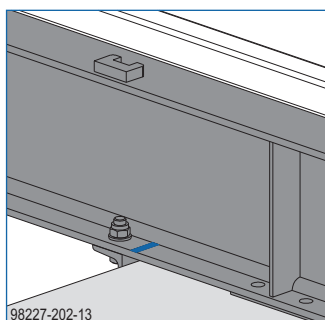

- ▶ Tighten the floor props up against the slab.

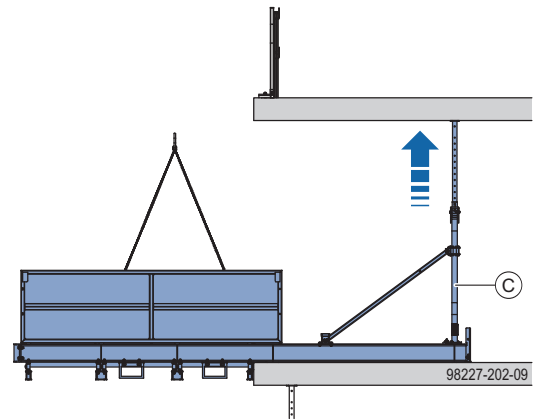

**C** Doka floor prop Eurex



### NOTICE

The head plates of the floor props must be force-locked against the underside of the slab.



### WARNING

Risk of loading platform falling!

- ▶ Secure the loading platform with one Doka express anchor in each of the two front support plates.

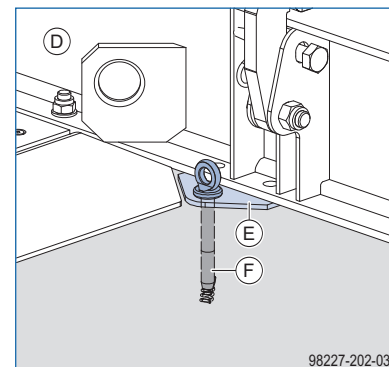

**D** Main beam

**E** Support plate front

**F** Doka express anchor 16x125mm



Follow the directions in the 'Doka express anchor 16x125mm' User Information booklet!

- ▶ Detach the loading platform from the crane.
- ▶ Close the guardrail system/railing at the slab edge all the way up to the loading platform on both sides.

## Fixing option - anchored through the slab

### **WARNING**

Risk of falling at open edges!

- ▶ Use appropriate personal fall-arrest system equipment when working on unsecured slab edges (e.g. safety harness).
- ▶ Suitable attachment points must be defined by an approved person appointed by the contractor.

- ▶ Drill holes (min.  $\varnothing$  30 mm (0'-1 1/4")) for anchoring the loading platform in the slab.

### Drilling pattern for tie rod

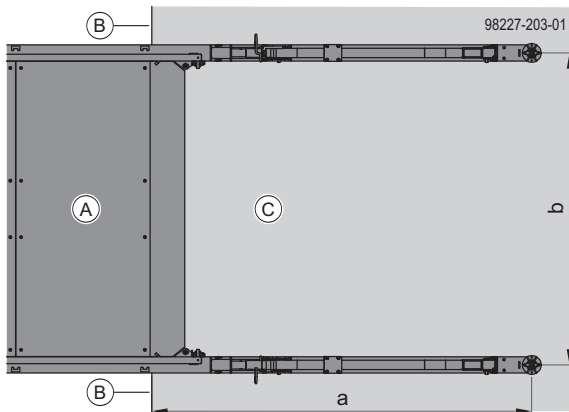

a ... 2830 mm (9'-3 1/2") space between slab edge and drilled hole  
 b ... 2325 mm (7'-7 1/2") centre-to-centre distance between the holes

- A** Loading platform
- B** Slab edge
- C** Floor-slab

### **NOTICE**

- ▶ Before lifting the loading platform into position, check that the slab is flat.  
 If the slab is not flat, place suitable packing material underneath the support plates.

- ▶ Manoeuvre the lifting platform into position in the building.

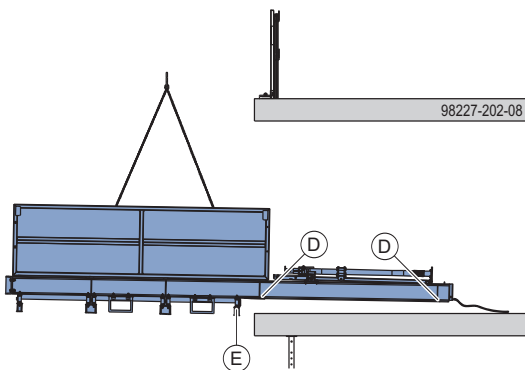

- D** Support plates for load introduction
- E** End cross-beam

### **NOTICE**

- The end cross-beam of the loading platform must be seated tight against the slab edge.
- The support plates must be in full-surface contact with the slab.



Marks on the main beam make the loading platform easier to position if the slab has a straight edge.

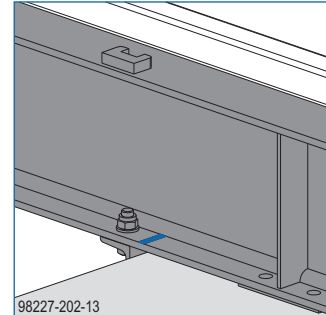

Until it is anchored, the loading platform can be **temporarily secured with the floor props of the main beams**. After anchoring, lay the floor props of the main beams flat.

- ▶ Anchor the main beams of the loading platform. Secure the tie rods at both ends with super plates and hexagon nuts.

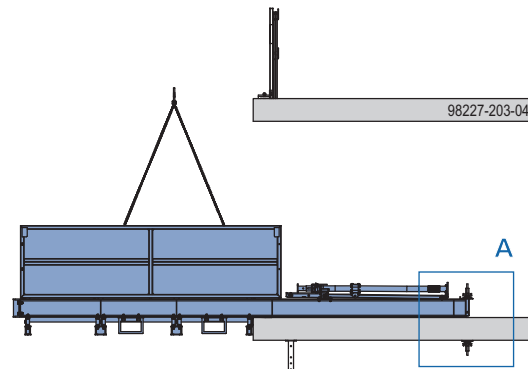





**Tie-rod wrench 15.0/20.0**

For turning and holding the tie rods.

- ▶ Detach the loading platform from the crane.
- ▶ Close the guardrail system/railing at the slab edge all the way up to the loading platform on both sides.

**Close-up A**

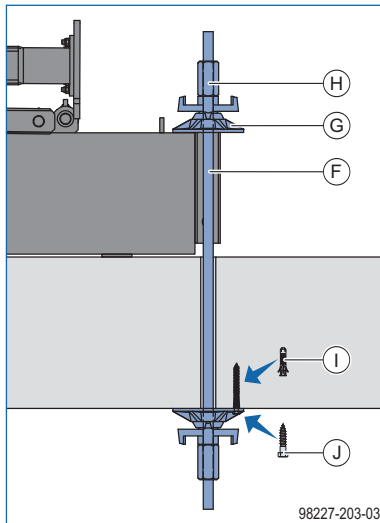

- F** Tie rod 20.0mm  
(min. length = slab thickness + 650 mm (2'-1 1/2"))
- G** Super plate 20.0mm
- H** Hexagon nut 20.0mm
- I** Dowel Ø12
- J** Hexagon-head wood screw 10x80

**⚠ WARNING**  
**Risk of loading platform falling!**  
 Make sure that the super plates are not unknowingly loosened on the storey below!

- ▶ Secure the super plate with a screw and heavy-duty dowel.
- ▶ Mark the super plates with red paint.
- ▶ Instruct the site crew accordingly.

**⚠ WARNING**  
**Risk of loading platform falling!**  
 ▶ Secure the loading platform with one Doka express anchor in each of the two front support plates.

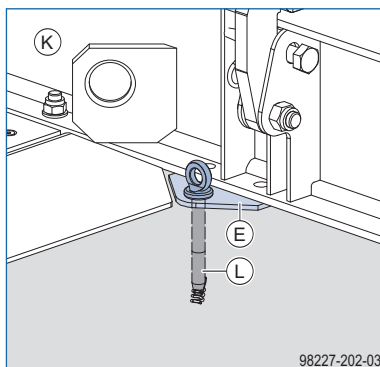

- E** Support plate front
- K** Main beam
- L** Doka express anchor 16x125mm



Follow the directions in the 'Doka express anchor 16x125mm' User Information booklet!

# Operation



## NOTICE

Risk of collision when manoeuvring platform cargo.

- Leave enough space between the main beams of the loading platform and the platform cargo.

### Example: clamped in place between two slabs

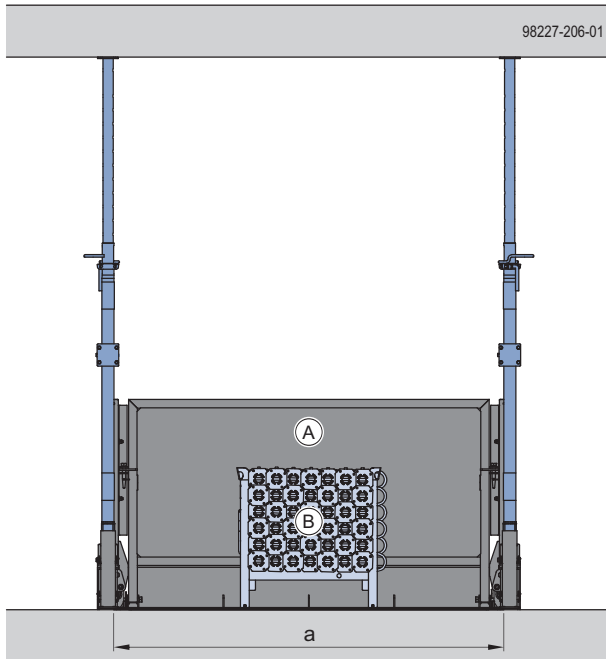

a ... 2.09 m (6'-10 1/4")

**A** Loading platform 2.45x3.20m 3.0t (8'-0"x10'-6" 6613 lbs)

**B** Doka stacking pallet 1.55x0.85m

### Example: anchored through the slab

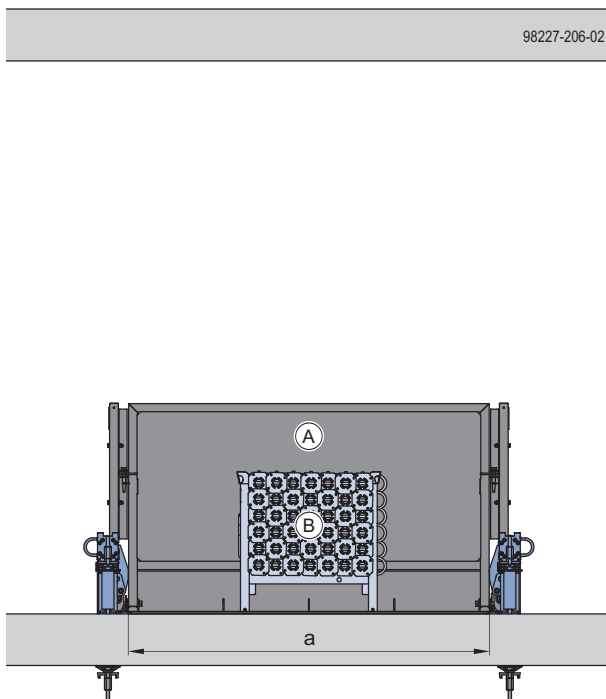

a ... 2.09 m (6'-10 1/4")

**A** Loading platform 2.45x3.20m 3.0t (8'-0"x10'-6" 6613 lbs)

**B** Doka stacking pallet 1.55x0.85m

# Repositioning

## General instructions on repositioning

**! WARNING**  
 Reposition only one loading platform at a time and only when it is empty.

- ▶ The presence of material on the platform during the repositioning operation is prohibited.
- ▶ The presence of persons on the platform during the repositioning operation is prohibited.

**! WARNING**  
 Risk of falling at open edges!

- ▶ Use appropriate personal fall-arrest system equipment when working on unsecured slab edges (e.g. safety harness).
- ▶ Suitable attachment points must be defined by an approved person appointed by the contractor.

**! NOTICE**

- Max. wind speed during repositioning of the loading platform: 72 km/h (45 mph).
- Be aware of the risk of collision when repositioning the loading platform (edge protection, slab edge).

## Fixing option - clamped in place between two slabs

- ▶ Attach a tag-line to the loading platform.
- ▶ Attach the Doka 4-part chain to the four lifting points on the loading platform.

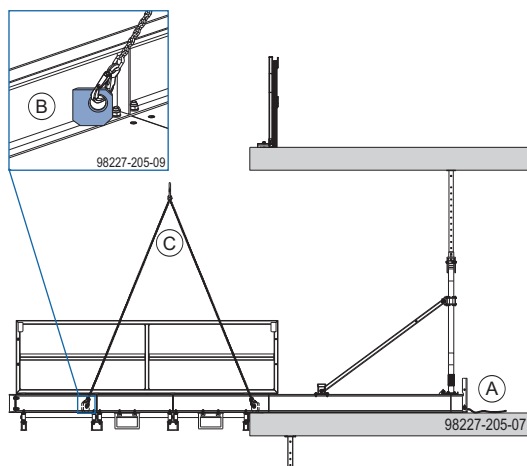

- A** Tag-line
- B** Crane lifting point
- C** Doka 4-part chain 3.20m



If clear room height is 2.70 m (8'-10 1/4") or more the loading platform can be lifted into position with the floor props vertical. The inner tubes must be in the lowered position.



**NOTICE**

If clear room height is less than 2.70 m (8'-10 1/4") the loading platform has to be repositioned with the floor props laid flat (see the section headed '[General instructions for site-erection](#)').



**NOTICE**

**Observe the following for prop lengths over 350 cm:**

Reposition the loading platform with the floor props laid flat if the clearance between the lowered floor props and the floor-slab is 40 cm or less.

- ▶ Remove the Doka express anchors.
- ▶ Back off the floor props and fully lower the inner tubes.

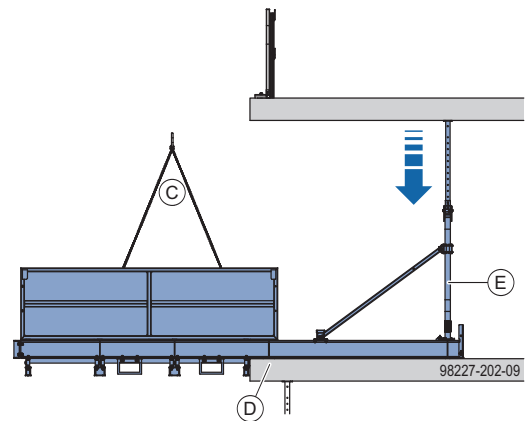

- C** Doka 4-part chain 3.20m
- D** Doka express anchor 16x125mm
- E** Doka floor prop Eurex

- ▶ Manoeuvre the loading platform clear of the building.

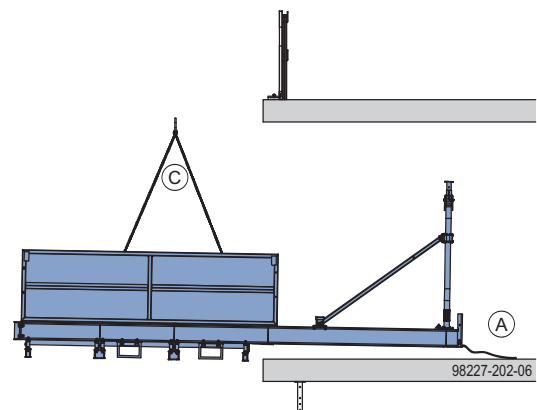

- A** Tag-line
- C** Doka 4-part chain 3.20m

- ▶ Manoeuvre the loading platform to the new location (see the section headed '[Mounting to the structure](#)').

## Fixing option - anchored through the slab

- ▶ Attach a tag-line to the loading platform.
- ▶ Attach the Doka 4-part chain to the four lifting points on the loading platform.

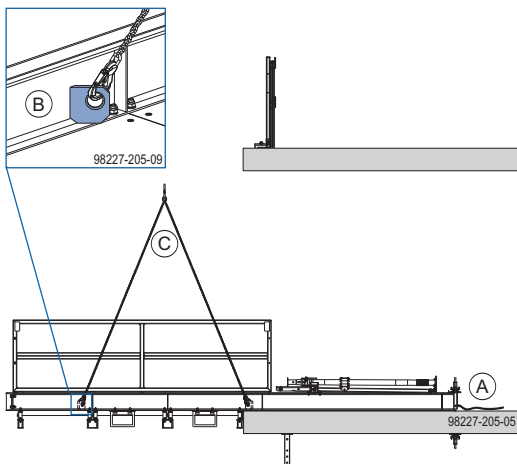

- A Tag-line
- B Crane lifting point
- C Doka 4-part chain 3.20m

- ▶ Remove the Doka express anchors.
- ▶ Remove the hexagon nut and the super plate on the underside of the slab.

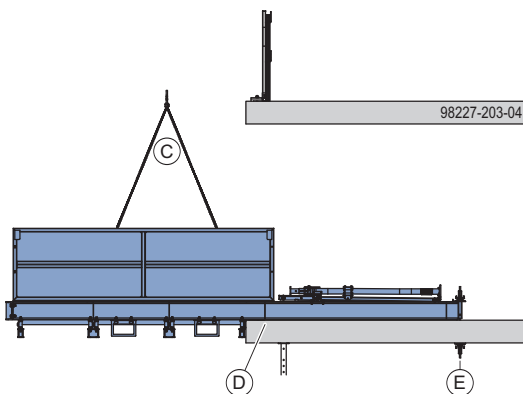

- C Doka 4-part chain 3.20m
- D Doka express anchor 16x125mm
- E Tie rod 20.0mm and Super plate 20.0mm



### Tie-rod wrench 15.0/20.0

For turning and holding the tie rods.

- ▶ Pull the tie rod with super plate and hexagon nut up and out.

- ▶ Manoeuvre the loading platform clear of the building.

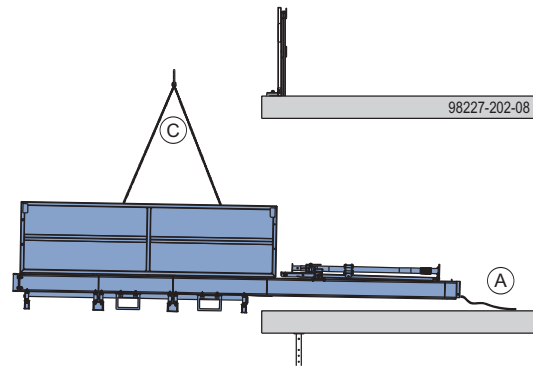

- A Tag-line
- C Doka 4-part chain 3.20m

- ▶ Manoeuvre the loading platform to the new location (see the section headed '[Mounting to the structure:](#)').

# General

## Additional areas of use

### Extra-long loads

---



If extra-long loads have to be set down on the loading platform, the end railing can be temporarily removed.

**WARNING**

Falling hazard!

- ▶ Use a personal fall-arrest system (e.g. safety harness).
- ▶ Suitable attachment points must be defined by an approved person appointed by the contractor.

**NOTICE**

Separate statical verification is required for set-down of extra-long loads.

# Transporting, stacking and storing

## Stacking and delivery condition



### NOTICE

- The loading platform has to be set down on a flat, horizontal surface of sufficient load-bearing capacity.
- Stack max. 4 loading platforms on top of one another! Corresponding transport supports are present.

### Delivery condition

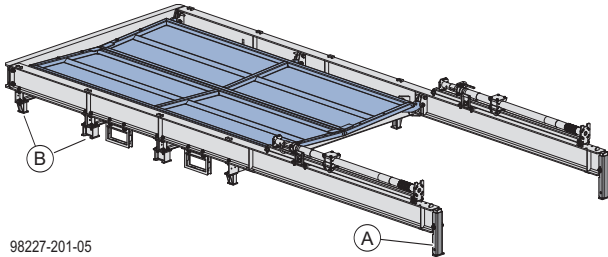

98227-201-05

**A** Transport support

**B** Height distancer

### Stacked condition

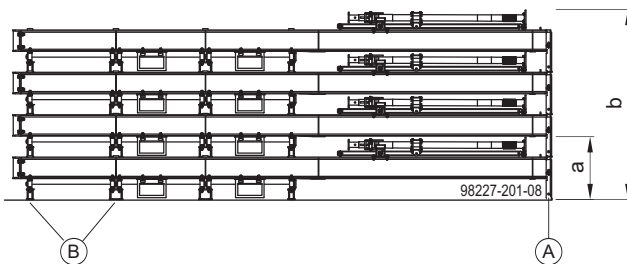

98227-201-08

a ... 697 mm (2'-3 1/2")

b ... 2122 mm (6'-11 1/2")

**A** Transport support

**B** Height distancer

## Preparing loading platform for transport

- Check the floor prop type and the orientation of the floor props and make changes as necessary.
  - Doka floor props Eurex 20 top 350 installed (as-delivered condition).
  - Slotted holes of the floor props are to the side, aligned with the loading platform.
- Return the transport support to the stacking and delivery condition (see the section headed '[Stacking and delivery condition](#)').
- Removal of the floor props is the reverse of the installation procedure (see the section headed '[Installing the floor props](#)').
- Removal of the side and end railings is the reverse of the installation procedure (see the section headed '[Mounting the railing](#)').
- Use screws to secure the sleeper so that it cannot slide out of position. Use the holes in the side railing.

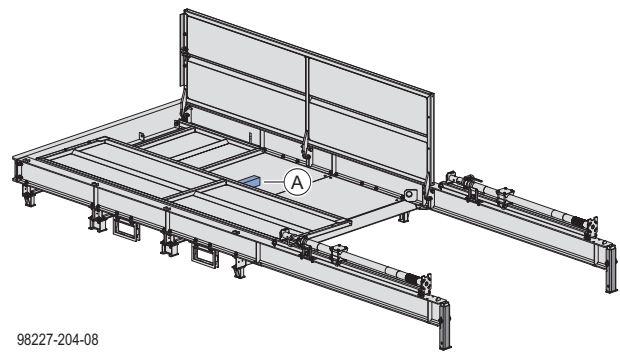

98227-204-08

**A** Sleeper

### Transport condition of the floor prop

- Push the fastening clamp through from the outside toward the inside.
- Tighten the adjusting nut up against the fastening clamp.
- Secure the toggle lever (with adhesive tape) so that it cannot slide out of position.

Storage and stacking position, floor prop

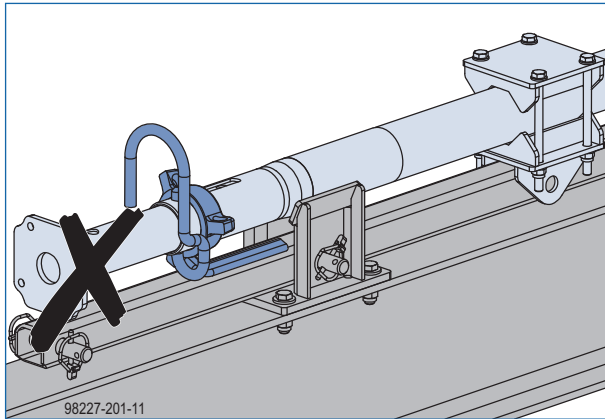
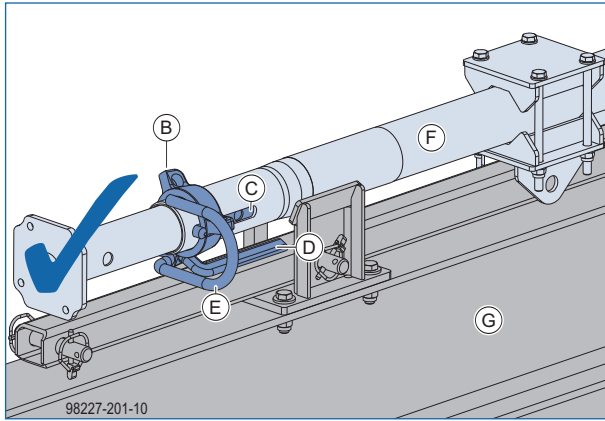

- B** Adjusting nut
- C** Slotted hole
- D** Toggle lever
- E** Fastening clamp
- F** Floor prop Eurex 20 top 350
- G** Main beam (inside)

## Transporting loading platforms

The design allows 4 loading platforms to be stacked on a truck for transport.



**NOTICE**

- For transport by truck, no additional material must be stowed on or between the loading platforms.
- Side railings and end railings must be folded down for transport (see [Stacking and delivery condition](#)).

**Transport by truck**

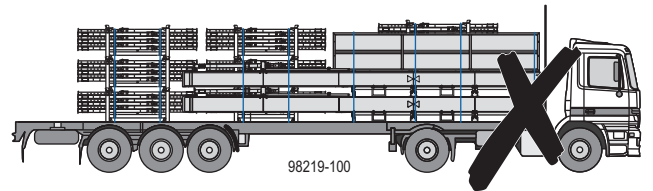
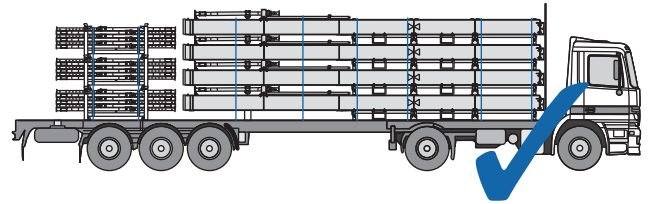

## Lifting by crane

The loading platform has four lifting points welded to the main beams for repositioning by crane.



### NOTICE

- Reposition only one loading platform at a time.
- Reposition the loading platform only when it is empty.
- Length of the crane lifting tackle min. 3.20 m (10'-6").
- Sling angle  $\beta$  max. 30°.

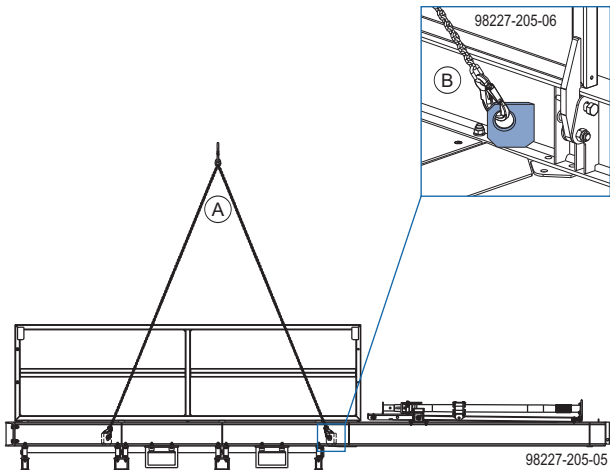

**A** Doka 4-part chain 3.20m

**B** Crane lifting point

## Doka 4-part chain 3.20m

The Doka 4-part chain 3.20m (10'-6") is a universal slinging means with integral **eye hooks** for transporting Doka loading platforms.

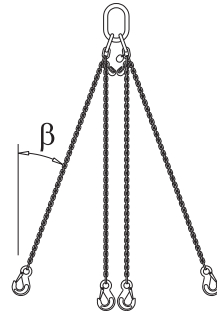

The Doka 4-part chain 3.20m (10'-6") can be adjusted to the centre-of-gravity position by shortening the length of individual chains.

### Max. working load limit $P_{max}$ :

	Sling angle $\beta$			
	0°	0°-30°	30°-45°	45°-60°
Using one chain	1400 kg (3000 lbs)	-	-	-
Using two chains	-	2400 kg (5200 lbs)	2000 kg (4400 lbs)	1400 kg (3000 lbs)
Using all four chains	-	3600 kg (7900 lbs)	3000 kg (6600 lbs)	2120 kg (4600 lbs)



Follow the directions in the 'Doka 4-part chain 3.20m' Original Operating Instructions!

## Repositioning by forklift truck

The loading platform has forklift pockets on the underside of the main beams for repositioning by forklift truck.



### NOTICE

- Reposition only one loading platform at a time.
- Reposition the loading platform only when it is empty.
- Use a correspondingly powerful forklift truck fitted with extra-long fork tines (min. 2.50 m (8'-2 1/2")).

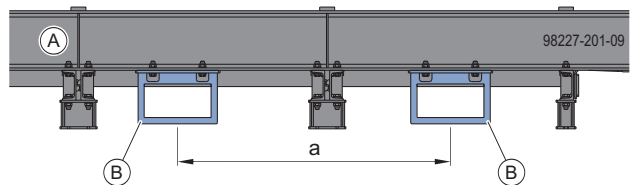

a ... 1100 mm (3'-7 1/4")

**A** Main beam









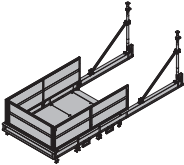

**B** Forklift pockets

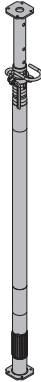

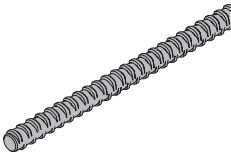

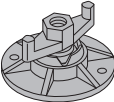
# Checklist for inspection

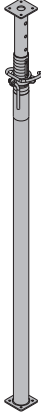
The supervisor must perform a complete sight-check of the following elements to ensure that they are correctly installed and that no damage or defects have occurred.

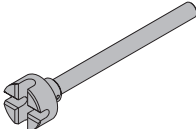
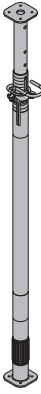
<b>CONTRACTOR:</b>		<b>SUPERVISOR:</b>	
<b>CONSTRUCTION PROJECT:</b>		<b>INSTALLATION PERIOD:</b>	
<b>SERIAL NUMBER OF THE LOADING PLATFORM:</b>		<b>USAGE LOCATION:</b>	
POS	ELEMENT TO BE CHECKED		CHECKED
1	Main beam	No visible damage	
2	Platform decking	No visible damage + bolted to main beams	
3	Crane lifting points	No visible damage to steel lifting eyes and weld seams	
4	Railings	No visible damage + all threaded fasteners/pins installed	
5	Floor props	Screw-jack function	
6	Floor props	Security of hinge plate to prop foot and to main beam	
7	Floor props	Security of diagonal brace connector	
8	Diagonal brace	Installed	
9	Floor props	Floor props vertically upright on the main beams	
10	Transport supports	No visible damage + correct position for the intended use	
<b>Before disconnecting from the crane:</b>			
11	The loading platform is correctly positioned (end cross-beam of the decking must be tight against the slab edge).		
12	The floor props are screwed tight and force-locked against the slab or the anchorages through the slab are installed.		
13	Anchorages for the horizontal loads are installed on both main beams.		
14	Edge protection system is in place up to the loading platform on both sides.		
Notes (record of deformations / damage / incorrect installation, etc.)			
<b>DATE:</b>		<b>SIGNATURE:</b>	

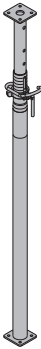
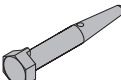
	[kg]	Article N°		[kg]	Article N°	
<b>Doka loading platform 2.45x3.20m 3.0t</b> Doka-Ausfahrbühne 2,45x3,20m 3,0t 	1580.0	586391000		<b>Doka floor prop Eurex 20 top 350</b> Length: 198 - 350 cm <b>Doka floor prop Eurex 20 top 400</b> Length: 223 - 400 cm <b>Doka floor prop Eurex 20 top 550</b> Length: 298 - 550 cm Doka-Deckenstütze Eurex 20 top Galvanised	17.4 21.6 32.3	586088400 586089400 586090400
<b>Doka express anchor 16x125mm</b> Doka-Expressanker 16x125mm  Galvanised Length: 18 cm	0.31	588631000				
<b>Doka coil 16mm</b> Doka-Coil 16mm  Galvanised Diameter: 1.6 cm	0.009	588633000				
<b>Tie rod 20.0mm galvanised 0.50m</b> <b>Tie rod 20.0mm galvanised 0.75m</b> <b>Tie rod 20.0mm galvanised 1.00m</b> <b>Tie rod 20.0mm galvanised 1.25m</b> <b>Tie rod 20.0mm galvanised 1.50m</b> <b>Tie rod 20.0mm galvanised 2.00m</b> <b>Tie rod 20.0mm galvanised 2.50m</b> <b>Tie rod 20.0mm galvanised .....m</b> <b>Tie rod 20.0mm non-treated 0.50m</b> <b>Tie rod 20.0mm non-treated 0.75m</b> <b>Tie rod 20.0mm non-treated 1.00m</b> <b>Tie rod 20.0mm non-treated 1.50m</b> <b>Tie rod 20.0mm non-treated 2.00m</b> <b>Tie rod 20.0mm non-treated .....m</b> Ankerstab 20,0mm 	1.3 1.9 2.5 3.2 3.8 5.0 6.3 2.5	581411000 581417000 581412000 581418000 581413000 581414000 581430000 581410000		<b>Doka floor prop Eurex 20 eco 400</b> Length: 223 - 400 cm <b>Doka floor prop Eurex 20 eco 450</b> Length: 248 - 450 cm <b>Doka floor prop Eurex 20 eco 550</b> Length: 298 - 550 cm Doka-Deckenstütze Eurex 20 eco Galvanised	21.8 24.1 32.0	586273000 586275000 586276000
<b>Super plate 20.0 B</b> Superplatte 20,0 B  Galvanised Height: 7 cm Diameter: 14 cm Width-across: 34 mm	2.0	581424000				
<b>Hexagon nut 20.0</b> Sechskantmutter 20,0  Galvanised Length: 7 cm Width-across: 41 mm	0.4	581420000		<b>Doka floor prop Eurex 30 top 400</b> Length: 223 - 400 cm <b>Doka floor prop Eurex 30 top 450</b> Length: 248 - 450 cm <b>Doka floor prop Eurex 30 top 550</b> Length: 303 - 550 cm Doka-Deckenstütze Eurex 30 top Galvanised	24.6 29.1 38.6	586095400 586119400 586129000
<b>Tie-rod wrench 15.0/20.0</b> Ankerstabschlüssel 15,0/20,0  Galvanised	1.8	580594000				

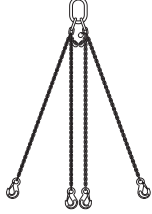
	[kg]	Article N°	[kg]	Article N°
<b>Doka floor prop Eurex 30 eco 400</b> Length: 223 - 400 cm <b>Doka floor prop Eurex 30 eco 450</b> Length: 248 - 450 cm Doka-Deckenstütze Eurex 30 eco Galvanised	24.2	586003000		
				
<b>Connecting pin 10cm</b> Verbindungsbolzen 10cm Galvanised Length: 14 cm	0.34	580201000		
				
<b>Spring cotter 5mm</b> Federvorstecker 5mm Galvanised Length: 13 cm	0.03	580204000		
				
<b>Doka 4-part chain 3.20m</b> Doka-Vierstrangkette 3,20m Follow the directions in the "Operating Instructions"!	15.0	588620000		
				
		CE		



Formwork & Scaffolding.  
**We make it work.**

---



[www.doka.com/loading-platform](http://www.doka.com/loading-platform)