

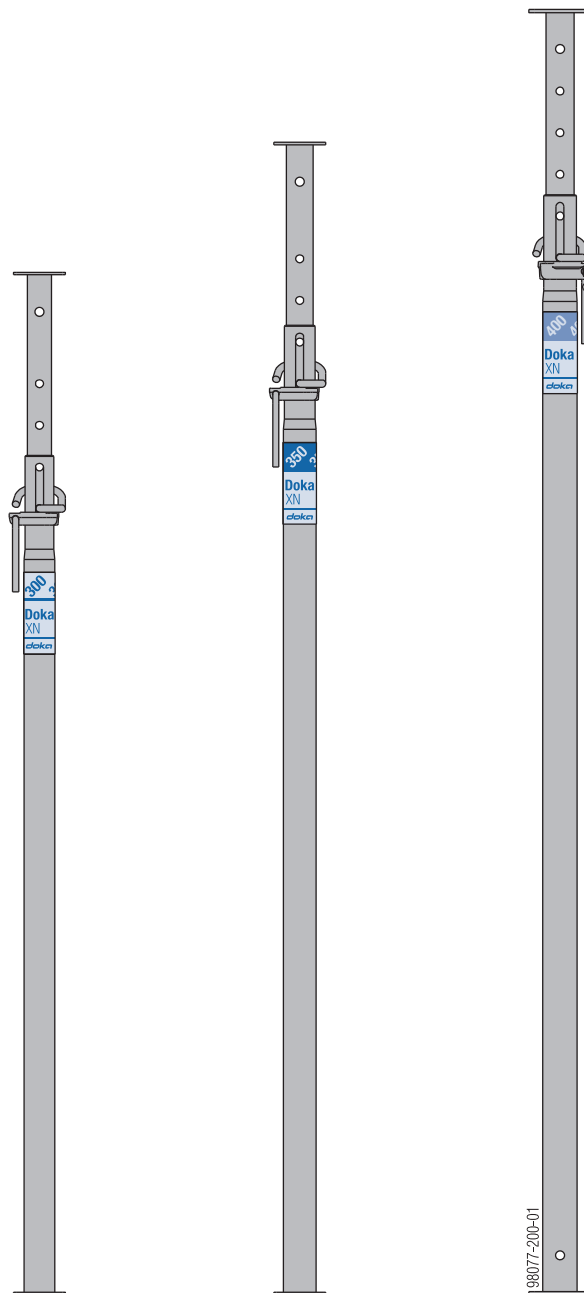

# Floor prop XN

## User Information

Instructions for assembly and use (Method statement)



# Contents

## **3 Introduction**

3 Elementary safety warnings

6 Intended use

7 Product description

## **8 Permissible load-bearing capacities**

## **9 Instructions for assembly and use (Method statement)**

## **10 Possible incorrect usages**

## **11 Technical condition**

## **12 Transporting, stacking and storing**

## **15 Article list**

# Introduction

## Elementary safety warnings

### User target groups

- This booklet is aimed at all persons who will be working with the Doka product or system that it describes. It contains information on the standard design for setting up this system, and on correct, compliant utilisation of the system.
- All persons working with the product described herein must be familiar with the contents of this booklet and with all the safety instructions it contains.
- Persons who are incapable of reading and understanding this booklet, or who can do so only with difficulty, must be instructed and trained by the customer.
- The customer is to ensure that the information materials provided by Doka (e.g. User Information booklets, Instructions for Assembly and Use, Operating Instruction manuals, plans etc.) are up to date and available to all users, and that they have been made aware of them and have easy access to them at the usage location.
- In the relevant technical documentation and form-work utilisation plans, Doka shows the workplace safety precautions that are necessary in order to use the Doka products safely in the usage situations shown.  
In all cases, users are obliged to ensure compliance with national laws, standards and regulations throughout the entire project and to take appropriate additional or alternative workplace safety precautions where necessary.

### Hazard assessment

- The customer is responsible for drawing up, documenting, implementing and continually updating a hazard assessment at every job-site. This booklet serves as the basis for the site-specific hazard assessment, and for the instructions given to users on how to prepare and utilise the system. It does not substitute for these, however.

### Remarks on this booklet

- This document can be used as general Instructions for Assembly and Use (Method Statement) or be incorporated into site-specific Instructions for Assembly and Use (Method Statement).
- **The graphics, animations and videos in this document or app sometimes depict partially assembled assemblies and may require additional safety equipment and/or measures to comply with safety regulations.**  
The customer must ensure all applicable regulations are complied with, even if they are not shown or implied in the graphics, animations and videos provided.
- **Individual sections contain further safety instructions and/or special warnings as applicable.**

### Planning

- Provide safe workplaces for those using the form-work (e.g. for when it is being erected/dismantled, modified or repositioned etc). It must be possible to get to and from these workplaces via safe access routes!
- **If you are considering any deviation from the details and instructions given in this booklet, or any application which goes beyond those described in the booklet, then revised static calculations must be produced for checking, as well as supplementary assembly instructions.**

### Regulations; industrial safety

- All laws, Standards, industrial safety regulations and other safety rules applying to the utilisation of our products in the country and/or region in which you are operating must be observed at all times.
- If a person or object falls against, or into, the side-guard component and/or any of its accessories, the component affected may only continue in use after it has been inspected and passed by an expert.

## Rules applying during all phases of the assignment

- The customer must ensure that this product is erected and dismantled, reset and generally used for its intended purpose in accordance with the applicable laws, standards and rules, under the direction and supervision of suitably skilled persons. These persons' mental and physical capacity must not in any way be impaired by alcohol, medicines or drugs.
- Doka products are technical working appliances which are intended for industrial / commercial use only, always in accordance with the respective Doka User Information booklets or other technical documentation authored by Doka.
- The stability and load-bearing capacity of all components and units must be ensured during all phases of the construction work!
- Do not step on or apply strain to cantilevers, closures, etc. until suitable measures to ensure their stability have been correctly implemented (e.g. by tie-backs).
- Strict attention to and compliance with the functional instructions, safety instructions and load specifications are required. Non-compliance can cause accidents and severe injury (risk of fatality) and considerable damage to property.
- Sources of fire in the vicinity of the formwork are prohibited. Heaters are permissible only when used correctly and situated a correspondingly safe distance from the formwork.
- Customer must give due consideration to any and all effects of the weather on the equipment and regards both its use and storage (e.g. slippery surfaces, risk of slipping, effects of the wind, etc.) and implement appropriate precautionary measures to secure the equipment and surrounding areas and to protect workers.
- All connections must be checked at regular intervals to ensure that they are secure and in full working order.  
In particular threaded connections and wedged connections have to be checked and retightened as necessary in accordance with activity on the jobsite and especially after out-of-the-ordinary occurrences (e.g. after a storm).
- It is strictly forbidden to weld Doka products – in particular anchoring/tying components, suspension components, connector components and castings etc. – or otherwise subject them to heating.  
Welding causes serious change in the microstructure of the materials from which these components are made. This leads to a dramatic drop in the failure load, representing a very great risk to safety.  
It is permissible to cut individual tie rods to length with metal cutting discs (introduction of heat at the end of the rod only), but it is important to ensure that flying sparks do not heat and thus damage other tie rods.  
The only articles which are allowed to be welded are those for which the Doka literature expressly points out that welding is permitted.

## Assembly

- The equipment/system must be inspected by the customer before use, to ensure that it is in an acceptable condition. Steps must be taken to exclude components that are damaged, deformed, or weakened due to wear, corrosion or rot (e.g. fungal decay).
- Using our safety and formwork systems together with those of other manufacturers can create risks that may lead to injury and damage to property. This requires separate verification by the user.
- The equipment/system must be assembled and erected in accordance with the applicable laws, standards and rules by trained customer personnel whilst maintaining any applicable safety inspections that may be required.
- It is not permitted to modify Doka products; such modifications constitute a safety risk.

## Closing the formwork

- Doka products and systems must be set up so that all loads acting upon them are safely transferred!

## Pouring

- Do not exceed the permitted fresh-concrete pressures. Over-high pouring rates overload the formwork, cause greater deflection and risk breakage.

## Stripping the formwork

- Do not strip out the formwork until the concrete has reached sufficient strength and the person in charge has given the order for the formwork to be stripped out!
- When stripping out the formwork, never use the crane to break concrete cohesion. Use suitable tools such as timber wedges, special pry-bars or system features such as Framax stripping corners.
- When stripping out the formwork, do not endanger the stability of any part of the structure, or of any scaffolding, platforms or formwork that is still in place!

## Transporting, stacking and storing

- Observe all country-specific regulations applying to the handling of formwork and scaffolding. For system formwork the Doka slinging means stated in this booklet must be used – this is a mandatory requirement.

If the type of sling is not specified in this document, the customer must use slinging means that are suitable for the application envisaged and that comply with the regulations.

- When lifting, always make sure that the unit to be lifted and its individual parts can absorb the forces that occur.
- Remove loose parts or secure them so that they cannot slip out of position and drop.
- When lifting formwork or formwork accessories with a crane, no persons must be carried along, e.g. on working platforms or in multi-trip packaging.
- All components must be stored safely, following all the special Doka instructions given in the relevant sections of this document!

## Maintenance

- Only original Doka components may be used as spare parts. Repairs may only be carried out by the manufacturer or authorised facilities.

## Miscellaneous

The weights as stated are averages for new material; actual weights can differ, depending on material tolerances. Dirt accretions, moisture saturation, etc. can also affect weight.

We reserve the right to make alterations in the interests of technical progress.

## Symbols used

The following symbols are used in this document:



### DANGER

This is a notifier drawing attention to an extremely dangerous situation in which non-compliance with this notifier will lead to death or severe, irreversible injury.



### WARNING

This is a notifier drawing attention to a dangerous situation in which non-compliance with this notifier can lead to death or severe, irreversible injury.



### CAUTION

This is a notifier drawing attention to a dangerous situation in which non-compliance with this notifier can lead to slight, reversible injury.



### NOTICE

This is a notifier drawing attention to a situation in which non-compliance with this notifier can lead to malfunctions or damage to property.



### Instruction

Indicates that actions have to be performed by the user.



### Sight-check

Indicates that you need to do a sight-check to make sure that necessary actions have been carried out.



### Tip

Points out useful practical tips.



### Reference

Cross-references other documents.

## Intended use

Doka floor props XN are adjustable telescopic steel props. Doka floor props XN serve as vertical props for temporary structures and can be used as free props and as temporary reshores.

Boundary conditions for use:

Extension length from 1.72 to 4.00 m

In special cases, boundary conditions can vary.

Observe the relevant information in the Doka technical documents.

Other use or use not in conformity with that stated above is non-intended use and requires the prior written approval from Doka!

## Product description

### Product features

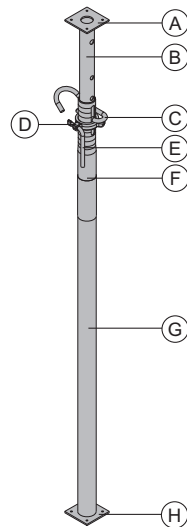

- A Head plate
- B Inner tube
- C Fastening clamp
- D Adjusting nut
- E Toggle lever
- F Type label
- G Outer tube
- H Baseplate

#### Features:

- Designed and galvanised for a long service life.
- Quick connection with the spring locked connecting pin for attaching various types of head adapters in a crane-handling-safe manner.
- Anti-dropout latch prevents the inner tube sliding out of the outer tube.
- Special thread geometry makes the floor prop easier to back off even under high load.
- When the floor prop is pushed in all the way, it still leaves a clear 10 cm gap so that the operator's hands are not trapped.
- For compatible removable folding tripods, see section [Removable folding tripod](#).



#### WARNING

- ▶ It is **not permitted** to use the Floor prop extension **0.50m**.

### Removable folding tripod

- Set-up aid for floor props.
- Swing-out legs offer flexibility for placement where space is at a premium, for example close to walls and in corners.

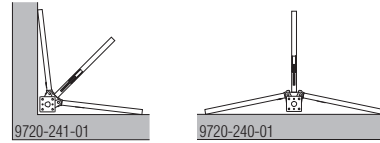

#### CAUTION

The removable folding tripod is no substitute for the bracing necessary for load-bearing towers.

- ▶ Use the removable folding tripod as a set-up aid only!

#### Compatible removable folding tripods and clamping ranges

Removable folding tripod	top		eco	
	Outer tube	Inner tube	Outer tube	Inner tube
XN 300	✓	—	✓	✓
XN 350	✓	—	✓	✓
XN 400	✓	—	✓	✓

# Permissible load-bearing capacities

## in accordance with ANSI

Permitted load-bearing capacity, in accordance with **ANSI**, as free (non-system-dependent) construction prop: **15.0 kN**

## in accordance with British Standards

Permitted load-bearing capacity, in accordance with **British Standards**, as temporary reshore, with a 2-fold safety factor: **22.5 kN**

## In accordance with the EN 1065 mathematical model

Used as free (non-system-dependent) construction props

Permitted load-bearing capacity [kN] as a function of extension length and position of the outer tube in accordance with the EN 1065 mathematical model:

Extension length [m]	300		XN 350		400	
	at bottom	at top	at bottom	at top	at bottom	at top
4.0	—	—	—	—	12.2	14.1
3.9	—	—	—	—	13.0	15.5
3.8	—	—	—	—	13.8	16.9
3.7	—	—	—	—	14.6	17.4
3.6	—	—	—	—	15.4	17.9
3.5	—	—	10.5	12.5	16.3	19.6
3.4	—	—	11.2	13.6	17.1	21.2
3.3	—	—	11.8	14.8	18.1	23.2
3.2	—	—	12.5	15.9	19.1	25.2
3.1	—	—	12.9	17.2	19.9	27.3
3.0	10.1	12.3	13.3	18.5	20.6	29.4
2.9	10.8	13.4	13.6	19.8	21.5	31.3
2.8	11.4	14.5	13.9	21.0	22.4	33.1
2.7	11.7	15.7	14.4	21.8	24.3	34.0
2.6	12.0	16.9	14.8	22.5	26.2	34.9
2.5	12.2	18.0	16.0		29.2	
2.4	12.4	19.2	17.3		32.2	
2.3	13.2	20.4	18.9		34.9	
2.2	14.0	21.6	20.5	—	—	
2.1	15.3	22.0	21.5	—	—	
2.0	16.6	22.5	22.5	—	—	
1.9	19.1		—	—	—	
1.8	20.3		—	—	—	
1.7	21.4		—	—	—	

Using as temporary reshores (props restrained)

Permitted load-bearing capacity [kN] as a function of extension length in accordance with the EN 1065 mathematical model:

Extension length [m]	XN		
	300	350	400
4.0	—	—	20.5
3.9	—	—	23.0
3.8	—	—	25.5
3.7	—	—	27.4
3.6	—	—	29.2
3.5	—	16.9	30.7
3.4	—	17.4	32.2
3.3	—	17.8	33.8
3.2	—	18.3	35.3
3.1	—	19.3	36.0
3.0	15.4	20.2	36.7
2.9	16.0	21.3	
2.8	16.6	22.4	
2.7	17.4	22.5	
2.6	18.2		
2.5	19.0		
2.4	19.8		
2.3	20.8		
2.2	21.7		
2.1	22.1		
2.0	22.5		—
1.9		—	
1.8		—	
1.7		—	

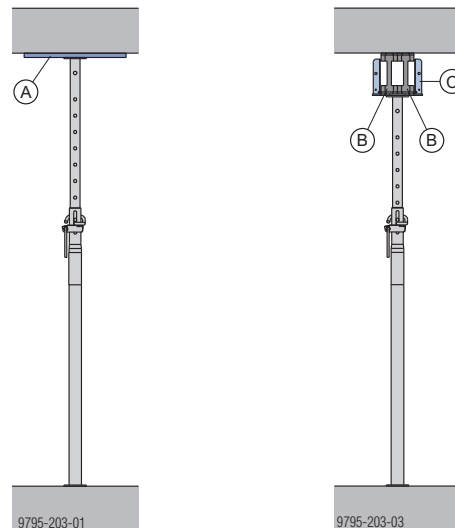

- A Formwork sheet
- B Doka beam H20
- C Lowering head H20 or 4-way head H20



### NOTICE

**When used as temporary reshoring:**

The baseplate stands directly on the floor, the head plate is directly against the slab (a formwork sheet or 2 Doka beams H20 can be used as packers at top).

# Instructions for assembly and use (Method statement)



## NOTICE

For manual transport, grip the floor prop only by the outer and inner tubes.



## Setting up with tripod



## CAUTION

The removable folding tripod is no substitute for the bracing necessary for load-bearing towers.

- ▶ Use the removable folding tripod as a set-up aid only!

Applies only for use as free-standing floor props.

- ▶ Roughly adjust the height of the floor props, using the fastening clamps.

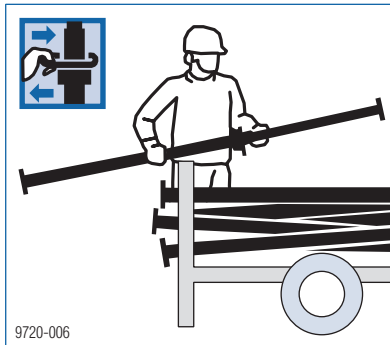

- ▶ Set up the removable folding tripod.



## NOTICE

- ▶ Do not oil or grease the clamping mechanism of the removable folding tripod.

- ▶ Put the floor prop into the tripod and fix it in place with the clamping lever.

Before anybody steps onto the formwork, check again to make sure that the props have been correctly fixed in the tripods.



- ▶ With the prop upright, use the adjusting nut for precision adjustment.

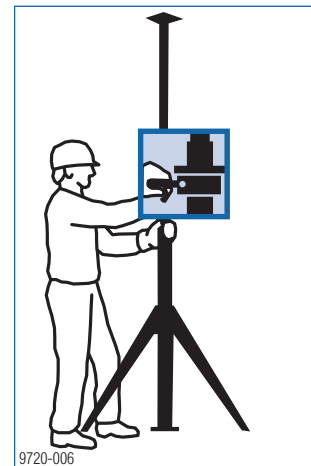

- The fastening clamp (A) has to be pushed all the way into the floor prop.
- The adjusting nut (B) has to be tightened into contact with the fastening clamp.



## Setting up without tripod

- ▶ When using props as temporary reshoring, press them sufficiently tightly against the floor structure to ensure that they cannot topple.

## Backing off and removing floor props

- ▶ Loosen the adjusting nut with a blow of the hammer and turn the floor prop to lower it.
- ▶ Bring the floor prop into a horizontal position.
- ▶ If necessary, open the fastening clamp and push the inner tube into the outer tube.
- ▶ Lay the floor prop on the stacking pallet.

# Possible incorrect usages



## WARNING

► The uses illustrated below are prohibited, as are other, similar uses!

Use only perfectly upright and plumb.

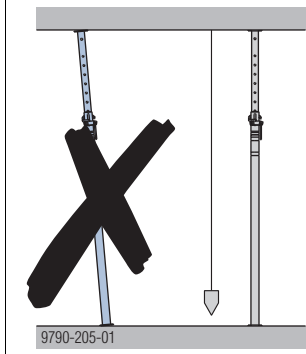

Baseplate must make full-surface contact with the ground.

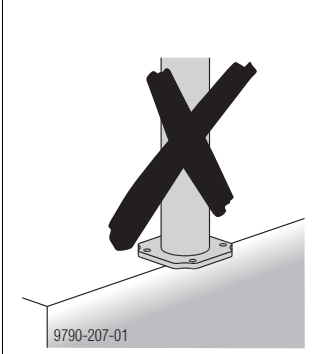

Place only on ground of adequate load-bearing strength.

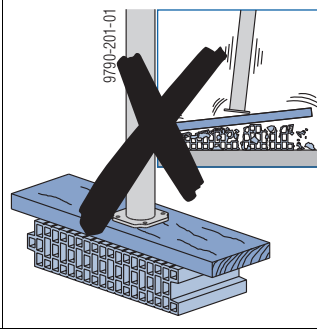
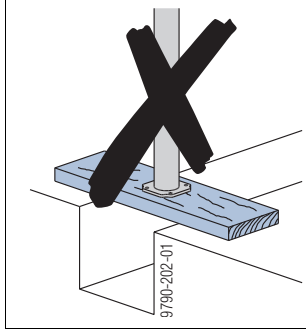

Do not attempt to use floor props one on top of another.

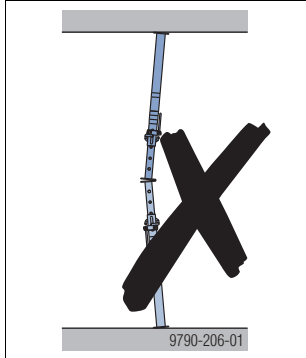

Do not use anchor rods or lengths of rebar as substitutes for the pegs.

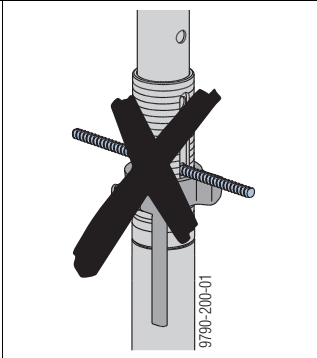

Do not use to support formwork panels.

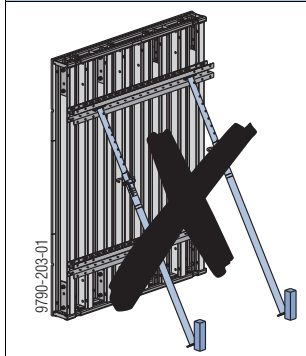

Do not use as trenching braces.

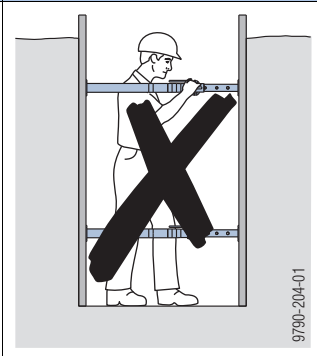

Do not use as barrier to close off openings.

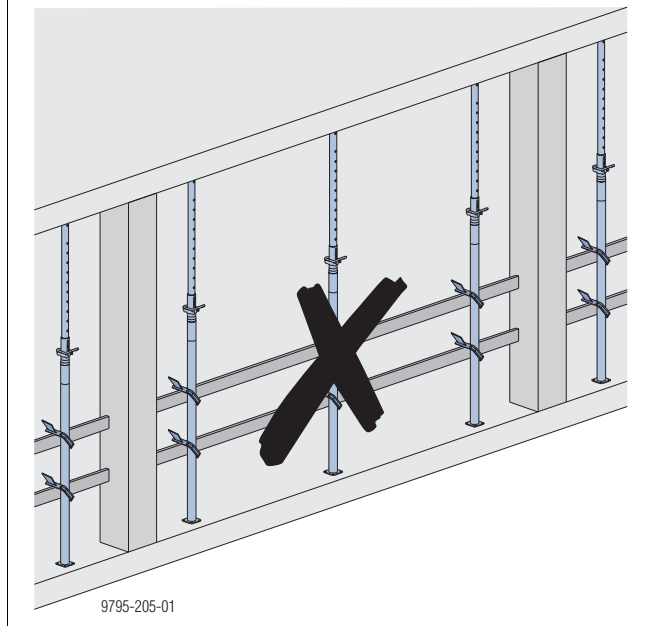
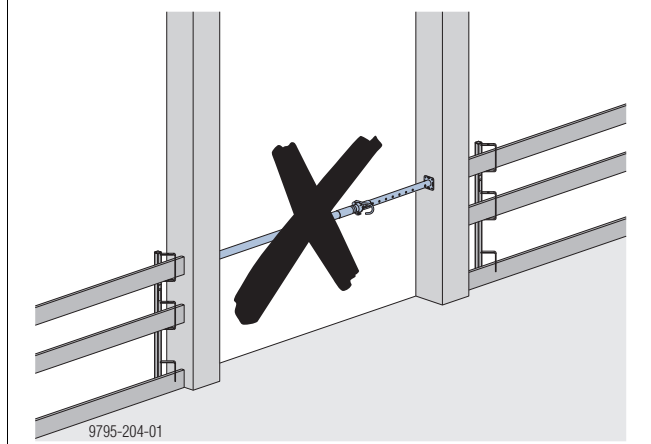

## Technical condition

The following quality criteria define the statically permitted degree of damage or weakening.

Use is prohibited if the damage is more extensive.

### Outer tube - inner tube

#### Head plate or baseplate bent out of shape

- **a max. 1 mm** outward and
- **b max. 3 mm** inward is permissible

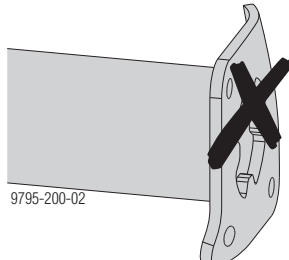
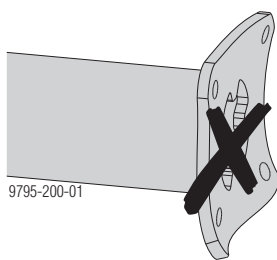
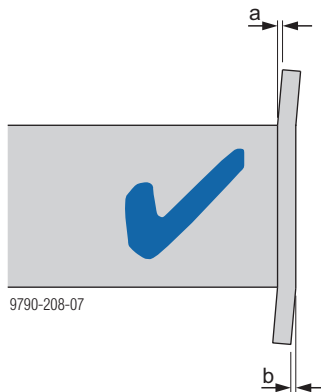

#### Cracks in welds

- Not permissible.

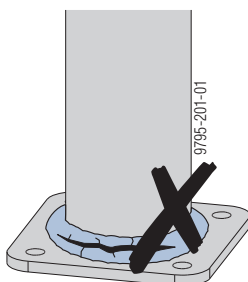

#### Threads

- must be greased over entire length and action must be smooth.

#### Inner tube

- When the inner tube is rotated inside the outer tube so that the U-bolt fixing-holes of both tubes are lined up, it must be possible to fully extend and retract the inner tube.

#### Widening

- of the pegging holes in the inner tube is permissible up to 2 mm.

# Transporting, stacking and storing

## Loading capacity

### Max. number of floor props per pallet

Floor prop	Stacking pallet	
	1.55x0.85m	1.20x0.80m
XN 300	48	
XN 350	48	
XN 400	42	

## Doka stacking pallet 1.55x0.85m and 1.20x0.80m

Storage and transport device for long items.

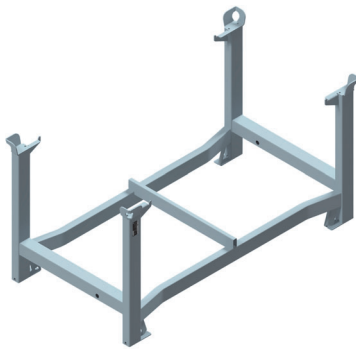

Permissible load-bearing capacity: 1100 kg (2420 lbs)  
 Permitted imposed stacking load: 5900 kg (13000 lbs)

## Using Doka stacking pallets as storage units

### Max. number of units on top of one another

Outdoors (on the site) Floor gradients up to 3%	Indoors Floor gradients up to 1%
2	6
It is not allowed to stack empty multi-trip boxes or pallets on top of one another!	



### NOTICE

- Stacked multi-trip boxes or pallets must have the heaviest boxes at the bottom and the lightest at the top!
- Castor wheels and Bolt-on castor set B must not be fitted to the bottom multi-trip packaging item in the stack.
- Secure multi-trip packagings with installed castor wheels using the fixing brake when parking.

## Using Doka stacking pallets as transport devices

Suitable transport appliances:

- Crane
- Forklift truck
- Pallet truck
- [Universal castor wheel for transport pallet](#)
- [Bolt-on castor set B](#)

## Lifting by crane



### NOTICE

- Multi-trip packaging items must be lifted individually.
- Use suitable lifting chains:
  - e.g. Doka 4-part chain 3.20m
  - Do not exceed the permitted working load limit of the lifting chains.
- Load the items centrally.
- Fasten the load to the stacking pallet (e.g. with strapping tape or lashing strap) so that it cannot slide or tip out.
- Sling angle  $\beta$  max. 30°!

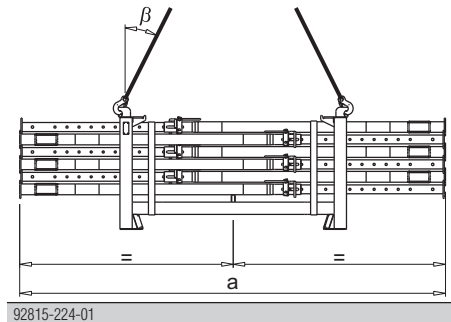

	a
Doka stacking pallet 1.55x0.85m	max. 4.5 m
Doka stacking pallet 1.20x0.80m	max. 3.0 m

## Repositioning by forklift truck or pallet stacking truck



### NOTICE

- Load the items centrally.
- Fasten the load to the stacking pallet (e.g. with strapping tape or lashing strap) so that it cannot slide or tip out.

## Doka multi-trip transport box

Storage and transport device for small items

### Doka multi-trip transport box 1.20x0.80m

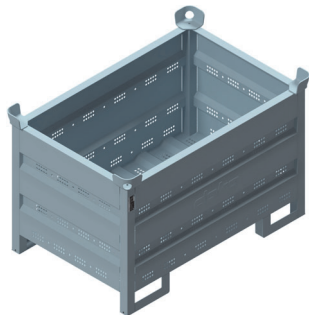

Permissible load-bearing capacity: 1500 kg (3300 lbs)  
Permitted imposed stacking load: 7850 kg (17300 lbs)

Different items in the Doka multi-trip transport box 1.20x0.80m can be kept separate with the **Multi-trip transport box partitions 1.20m or 0.80m**.

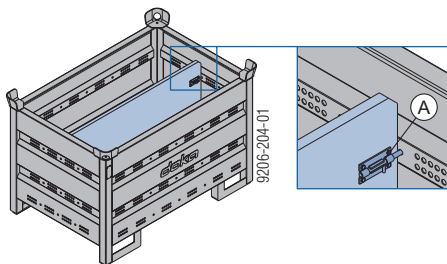

A Slide-bolt for fixing the partition

#### Possible ways of dividing the box

Multi-trip transport box partition	in the longitudinal direction	in the transverse direction
1.20m	max. 3 partitions	-
0.80m	-	max. 3 partitions

--	--

### Doka multi-trip transport box 1.20x0.80mx0.41m

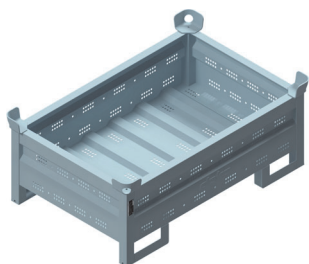

Permissible load-bearing capacity: 750 kg (1650 lbs)  
Permitted imposed stacking load: 7200 kg (15870 lbs)

## Using Doka multi-trip transport boxes as storage units

### Max. number of units on top of one another

Outdoors (on the site) Floor gradients up to 3%		Indoors Floor gradients up to 1%	
Doka multi-trip transport box 1.20x0.80m	1.20x0.80x0.41m	Doka multi-trip transport box 1.20x0.80m	1.20x0.80x0.41m
3	5	6	10
It is not allowed to stack empty multi-trip boxes or pallets on top of one another!			



#### NOTICE

- Stacked multi-trip boxes or pallets must have the heaviest boxes at the bottom and the lightest at the top!
- Castor wheels must not be fitted to the bottom multi-trip packaging in the stack.
- Secure multi-trip packagings with installed castor wheels using the fixing brake when parking.

## Using Doka multi-trip transport boxes as transport devices

Suitable transport appliances:

- Crane
- Forklift truck
- Pallet truck
- [Universal castor wheel for transport pallet](#)

### Lifting by crane



#### NOTICE

- Multi-trip packaging items must be lifted individually.
- Use suitable lifting chains:
  - e.g. Doka 4-part chain 3.20m
  - Do not exceed the permitted working load limit of the lifting chains.
- Sling angle  $\beta$  max. 30°!

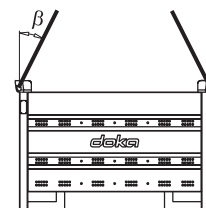

9206-202-01

### Repositioning by forklift truck or pallet stacking truck

The forks can be inserted under either the broadside or the narrowside of the containers.

## Universal castor wheel for transport pallet

---

The Universal castor wheel for transport pallet turns multi-trip packaging items into fast and manoeuvrable transport devices.

- 4 castor wheels needed per multi-trip packaging item.
- Compatible multi-trip packaging items:
  - Doka stacking pallets (all sizes)
  - Doka accessory box
  - Doka multi-trip transport box 1.20x0.80m
  - Doka skeleton transport box 1.70x0.80m
  - DokaXdek panel pallets (all sizes)
  - Dokadek infill beam pallet
  - Superdek beam pallet 1.22x1.10m



Follow the directions in the 'Universal castor wheel for transport pallet' User Information booklet.

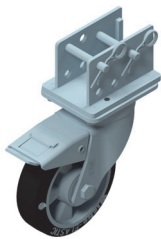

## Bolt-on castor set B

---

The Bolt-on castor set B turns multi-trip packaging items into fast and manoeuvrable transport devices.

- Suitable for drive-through access openings > 90 cm.
- Compatible multi-trip packaging items:
  - Doka stacking pallets (all sizes)
  - Doka accessory box
  - Dokadek infill beam pallet
  - Protective barrier Z pallet (all sizes)



Follow the directions in the 'Bolt-on castor set B' User Information booklet!

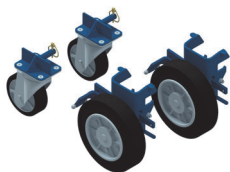





Formwork & Scaffolding.  
**We make it work.**

---



[www.doka.com/floor-props](http://www.doka.com/floor-props)