

Xsafe edge protection Z

User Information

Instructions for assembly and use (Method statement)

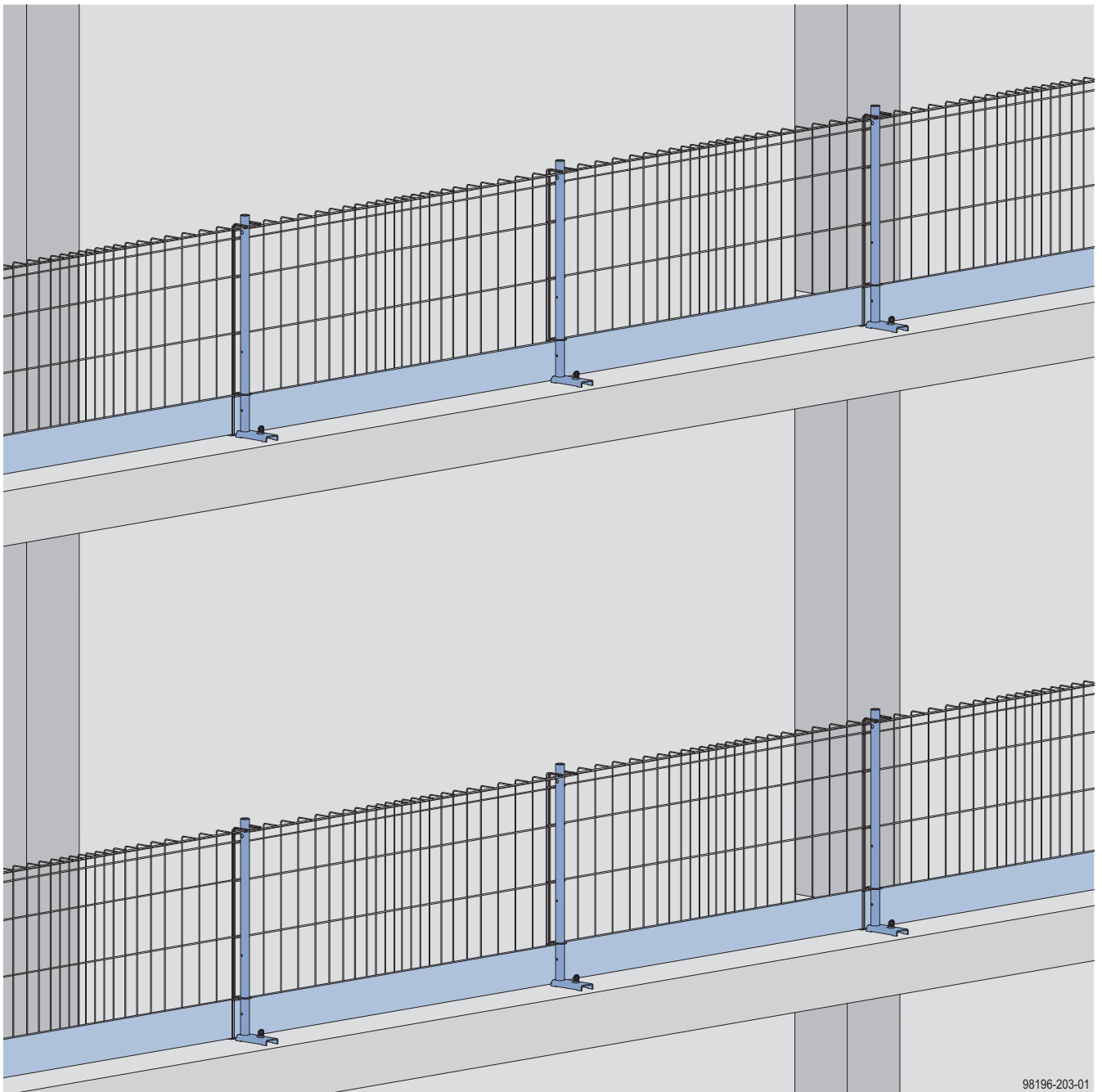

98196-203-01

Contents

4 Introduction

- 4 Elementary safety warnings
- 7 System description

8 Edge protection - railing height up to 1.20 m

- 10 Installing Handrail post Z 1.20m and safety barrier
- 12 Installing Handrail post XP and safety barrier
- 14 Practical examples
- 15 Structural design

16 Edge protection - railing height up to 1.80 m

- 17 Extending height of edge protection to barrier height 1.80 m
- 19 Structural design

21 General

- 21 Individual design options
- 22 Transporting, stacking and storing

28 Article list

Introduction

Elementary safety warnings

User target groups

- This booklet is aimed at all persons who will be working with the Doka product or system that it describes. It contains information on the standard design for setting up this system, and on correct, compliant utilisation of the system.
- All persons working with the product described herein must be familiar with the contents of this booklet and with all the safety instructions it contains.
- Persons who are incapable of reading and understanding this booklet, or who can do so only with difficulty, must be instructed and trained by the customer.
- The customer is to ensure that the information materials provided by Doka (e.g. User Information booklets, Instructions for Assembly and Use, Operating Instruction manuals, plans etc.) are up to date and available to all users, and that they have been made aware of them and have easy access to them at the usage location.
- In the relevant technical documentation and form-work utilisation plans, Doka shows the workplace safety precautions that are necessary in order to use the Doka products safely in the usage situations shown.
In all cases, users are obliged to ensure compliance with national laws, standards and regulations throughout the entire project and to take appropriate additional or alternative workplace safety precautions where necessary.

Hazard assessment

- The customer is responsible for drawing up, documenting, implementing and continually updating a hazard assessment at every job-site. This booklet serves as the basis for the site-specific hazard assessment, and for the instructions given to users on how to prepare and utilise the system. It does not substitute for these, however.

Remarks on this booklet

- This document can be used as general Instructions for Assembly and Use (Method Statement) or be incorporated into site-specific Instructions for Assembly and Use (Method Statement).
- **The graphics, animations and videos in this document or app sometimes depict partially assembled assemblies and may require additional safety equipment and/or measures to comply with safety regulations.**
The customer must ensure all applicable regulations are complied with, even if they are not shown or implied in the graphics, animations and videos provided.
- **Individual sections contain further safety instructions and/or special warnings as applicable.**

Planning

- Provide safe workplaces for those using the form-work (e.g. for when it is being erected/dismantled, modified or repositioned etc). It must be possible to get to and from these workplaces via safe access routes!
- **If you are considering any deviation from the details and instructions given in this booklet, or any application which goes beyond those described in the booklet, then revised static calculations must be produced for checking, as well as supplementary assembly instructions.**

Regulations; industrial safety

- All laws, Standards, industrial safety regulations and other safety rules applying to the utilisation of our products in the country and/or region in which you are operating must be observed at all times.
- If a person or object falls against, or into, the side-guard component and/or any of its accessories, the component affected may only continue in use after it has been inspected and passed by an expert.

Rules applying during all phases of the assignment

- The customer must ensure that this product is erected and dismantled, reset and generally used for its intended purpose in accordance with the applicable laws, standards and rules, under the direction and supervision of suitably skilled persons. These persons' mental and physical capacity must not in any way be impaired by alcohol, medicines or drugs.
- Doka products are technical working appliances which are intended for industrial / commercial use only, always in accordance with the respective Doka User Information booklets or other technical documentation authored by Doka.
- The stability and load-bearing capacity of all components and units must be ensured during all phases of the construction work!
- Do not step on or apply strain to cantilevers, closures, etc. until suitable measures to ensure their stability have been correctly implemented (e.g. by tie-backs).
- Strict attention to and compliance with the functional instructions, safety instructions and load specifications are required. Non-compliance can cause accidents and severe injury (risk of fatality) and considerable damage to property.
- Sources of fire in the vicinity of the formwork are prohibited. Heaters are permissible only when used correctly and situated a correspondingly safe distance from the formwork.
- Customer must give due consideration to any and all effects of the weather on the equipment and regards both its use and storage (e.g. slippery surfaces, risk of slipping, effects of the wind, etc.) and implement appropriate precautionary measures to secure the equipment and surrounding areas and to protect workers.
- All connections must be checked at regular intervals to ensure that they are secure and in full working order.
In particular threaded connections and wedged connections have to be checked and retightened as necessary in accordance with activity on the jobsite and especially after out-of-the-ordinary occurrences (e.g. after a storm).
- It is strictly forbidden to weld Doka products – in particular anchoring/tying components, suspension components, connector components and castings etc. – or otherwise subject them to heating.
Welding causes serious change in the microstructure of the materials from which these components are made. This leads to a dramatic drop in the failure load, representing a very great risk to safety.
It is permissible to cut individual tie rods to length with metal cutting discs (introduction of heat at the end of the rod only), but it is important to ensure that flying sparks do not heat and thus damage other tie rods.
The only articles which are allowed to be welded are those for which the Doka literature expressly points out that welding is permitted.

Assembly

- The equipment/system must be inspected by the customer before use, to ensure that it is in an acceptable condition. Steps must be taken to exclude components that are damaged, deformed, or weakened due to wear, corrosion or rot (e.g. fungal decay).
- Using our safety and formwork systems together with those of other manufacturers can create risks that may lead to injury and damage to property. This requires separate verification by the user.
- The equipment/system must be assembled and erected in accordance with the applicable laws, standards and rules by trained customer personnel whilst maintaining any applicable safety inspections that may be required.
- It is not permitted to modify Doka products; such modifications constitute a safety risk.

Closing the formwork

- Doka products and systems must be set up so that all loads acting upon them are safely transferred!

Pouring

- Do not exceed the permitted fresh-concrete pressures. Over-high pouring rates overload the formwork, cause greater deflection and risk breakage.

Stripping the formwork

- Do not strip out the formwork until the concrete has reached sufficient strength and the person in charge has given the order for the formwork to be stripped out!
- When stripping out the formwork, never use the crane to break concrete cohesion. Use suitable tools such as timber wedges, special pry-bars or system features such as Framax stripping corners.
- When stripping out the formwork, do not endanger the stability of any part of the structure, or of any scaffolding, platforms or formwork that is still in place!

Transporting, stacking and storing

- Observe all country-specific regulations applying to the handling of formwork and scaffolding. For system formwork the Doka slinging means stated in this booklet must be used – this is a mandatory requirement.
If the type of sling is not specified in this document, the customer must use slinging means that are suitable for the application envisaged and that comply with the regulations.
- When lifting, always make sure that the unit to be lifted and its individual parts can absorb the forces that occur.
- Remove loose parts or secure them so that they cannot slip out of position and drop.
- When lifting formwork or formwork accessories with a crane, no persons must be carried along, e.g. on working platforms or in multi-trip packaging.
- All components must be stored safely, following all the special Doka instructions given in the relevant sections of this document!

Maintenance

- Only original Doka components may be used as spare parts. Repairs may only be carried out by the manufacturer or authorised facilities.

Miscellaneous

The weights as stated are averages for new material; actual weights can differ, depending on material tolerances. Dirt accretions, moisture saturation, etc. can also affect weight.

We reserve the right to make alterations in the interests of technical progress.

Eurocodes at Doka

The permissible values stated in Doka documents (e.g. $F_{perm} = 70$ kN) are not design values (e.g. $F_{Rd} = 105$ kN), unless specified!

- It is essential to avoid confusing permissible values with design values!
- Doka documents will continue to state the permissible values.

Allowance has been made for the following partial factors:

- $\gamma_F = 1.5$
- $\gamma_{M, timber} = 1.3$
- $\gamma_{M, steel} = 1.1$
- $k_{mod} = 0.9$

Consequently, all the design values for an EC design calculation can be determined from the permissible values.

Symbols used

The following symbols are used in this document:



DANGER

This is a notifier drawing attention to an extremely dangerous situation in which non-compliance with this notifier will lead to death or severe, irreversible injury.



WARNING

This is a notifier drawing attention to a dangerous situation in which non-compliance with this notifier can lead to death or severe, irreversible injury.



CAUTION

This is a notifier drawing attention to a dangerous situation in which non-compliance with this notifier can lead to slight, reversible injury.



NOTICE

This is a notifier drawing attention to a situation in which non-compliance with this notifier can lead to malfunctions or damage to property.



Instruction

Indicates that actions have to be performed by the user.



Sight-check

Indicates that you need to do a sight-check to make sure that necessary actions have been carried out.



Tip

Points out useful practical tips.



Reference

Cross-references other documents.

System description

Xsafe edge protection Z leads to a safe and economical solution at the structure edge. The optimised design makes this edge protection system light but at the same time strong. It corresponds to EN 13374 class A and supports productive and safe working on the structure shell.

Labour-saving & easy to handle

- At only 13.3 kg, this is one of the lightest edge-protection barriers on the market.
- Easy to erect as there are so few individual parts.
- Speedy installation with self-explanatory system logic.

Time-saving & flexible

- Usable with the Handrail post Z 1.20m and Handrail post Z 0.60m for safety barrier heights up to 1.80 m.
- Can be combined with Handrail posts XP 1.20m and approved XP adapters for fixing to the structure.

Economical & functional

- Design focus is on the essential basic functions.
- Simple planning helps conserve resources.
- Xsafe edge protection Z can be supplied in any RAL-compatible customer colours. Minimum order quantity: 70 pcs. (= 1 full pallet)
- orderable 24/7 in the Doka Online Shop

Edge protection - railing height up to 1.20 m

with Handrail post Z 1.20m

Safety barriers

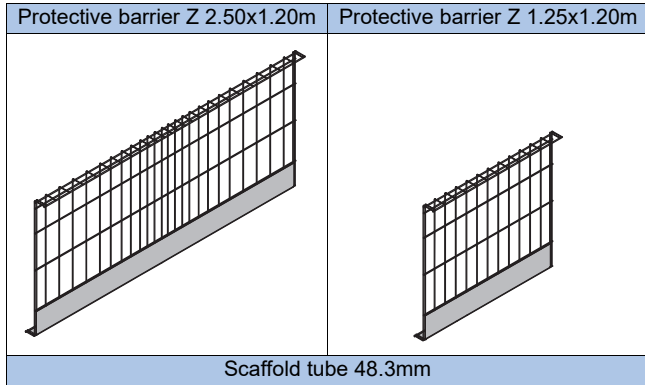

Handrail posts

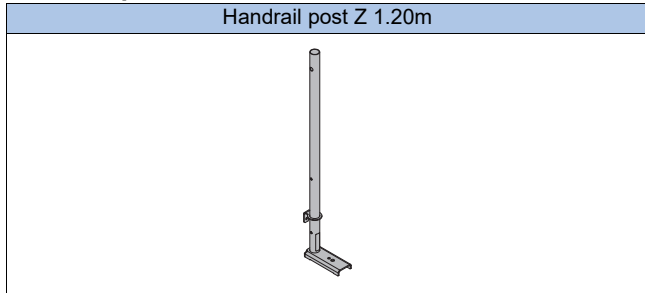

with Handrail post XP

Note:

Alternatively, the Xsafe protective barrier Z can also be used in combination with the Handrail post XP 1.20m or Handrail post XP flex 1.60m for railing height 1.20 m.



For detailed information about the Handrail post XP and about anchoring of approved XP adapters see the 'Xsafe edge protection XP' and the 'Doka express anchor 16x125mm' User Information booklets.

Handrail posts

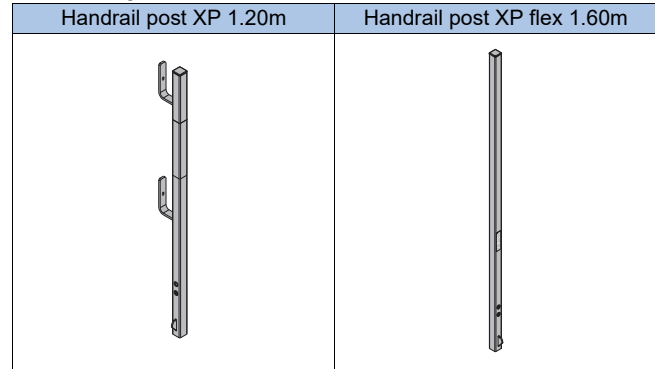

Holders

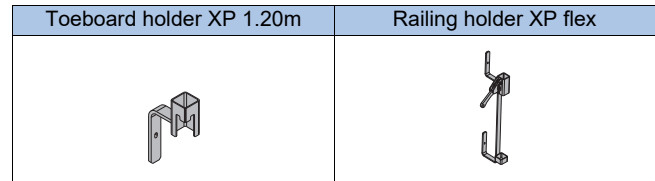

Fixing devices

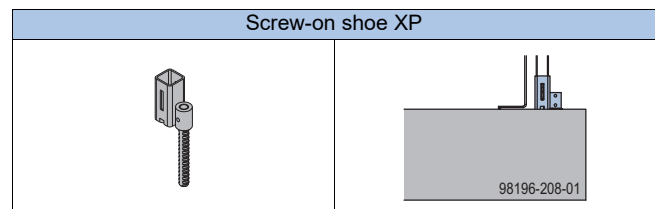
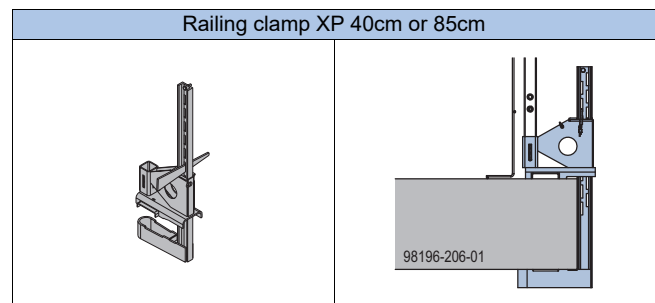
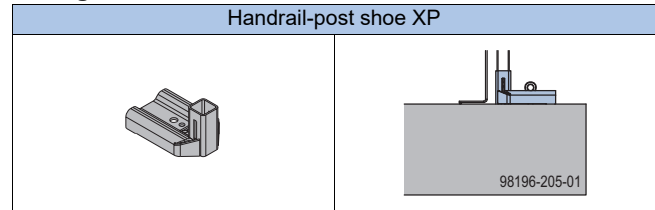

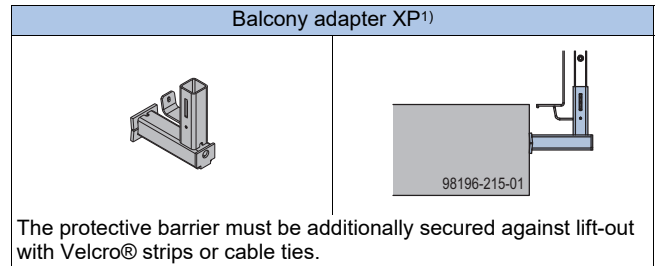
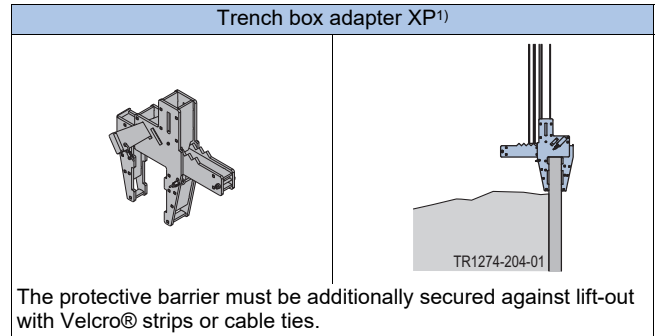
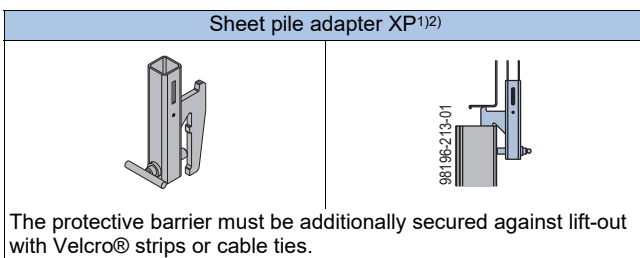
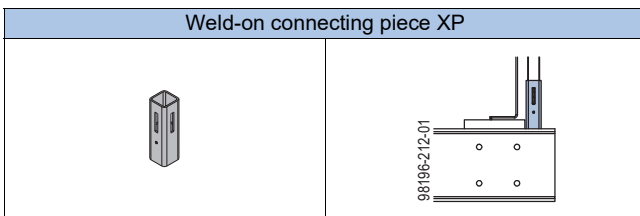
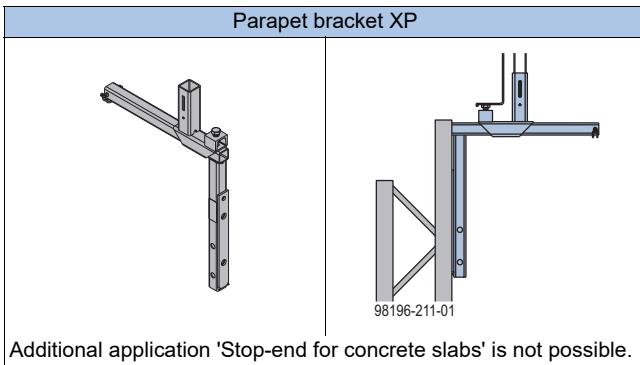
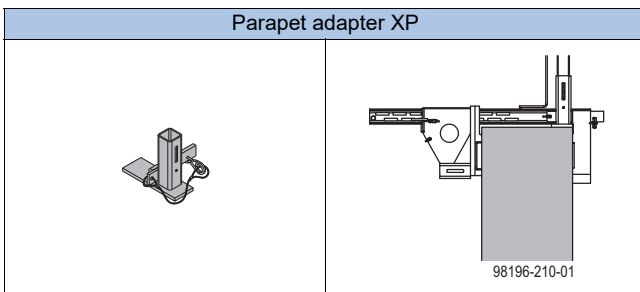
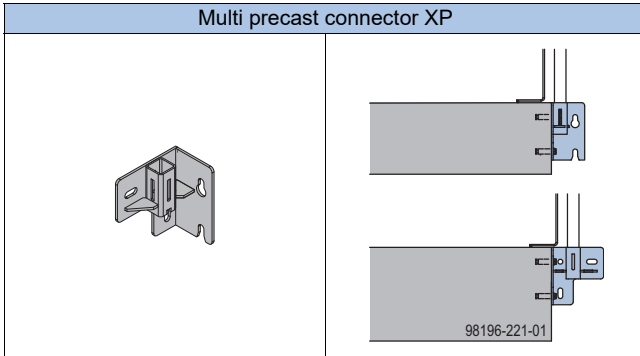
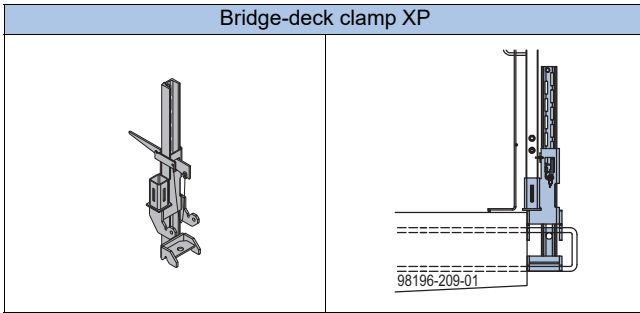

Installing Handrail post Z 1.20m and safety barrier

Installing the Handrail post Z 1.20m



NOTICE

- If no fall protection (such as a facade scaffold or platform) is in place when the side-guards are being mounted or dismantled, a personal fall-arrest system (PFAS) must be used.
- Suitable attachment points must be defined by an approved person appointed by the contractor.
- Only fix the connectors to components that can reliably transfer the forces involved.
- The permitted influence widths of the Handrail post Z and the permitted loads on the anchorages are given in the section headed [Structural design](#).



Follow the 'Doka express anchor 16x125mm' User Information booklet or the fitting instructions for the alternative anchor-bolt!

- ▶ Fix the Handrail post Z using a Doka express anchor 16x125mm or an alternative anchor-bolt (diam. 12 mm) with a minimum clamping length of 3 cm.

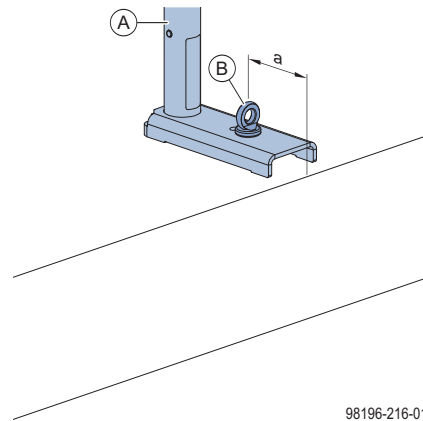

98196-216-01

a ... distance from edge min. 15 cm (with Doka express anchor 16x125mm)

A Handrail post Z

B Doka express anchor 16x125mm

Holes in Handrail post Z

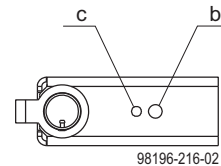

98196-216-02

b ... diam. 18 mm (for Doka express anchor 16x125mm)

c ... diam. 13 mm (for alternative anchor-bolt)



The handrail post must be facing towards the inside of the building.

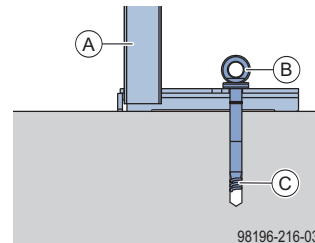

98196-216-03

A Handrail post Z

B Doka express anchor 16x125mm

C Doka coil 16mm

Installing the safety barriers

Installing the Protective barrier Z 1.20m

- ▶ Push the safety bow upwards until it hits the stop.

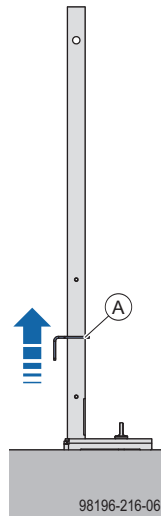

A Safety bow

- ▶ Engage the Protective barrier Z 1.20m in the handrail post from above and allow the safety bow to slide down.

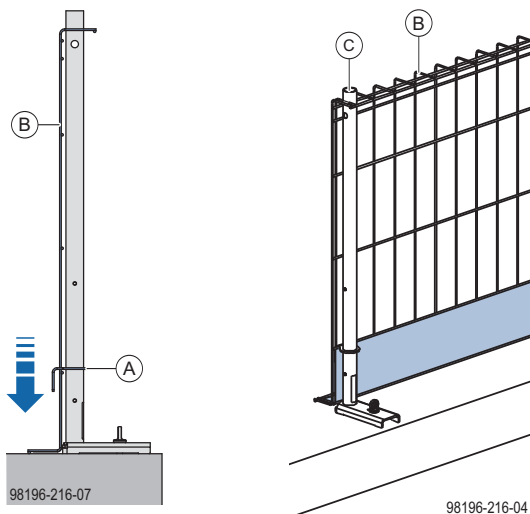

A Safety bow
B Protective barrier Z 2.50x1.20m or 1.25x1.20m
C Handrail post Z 1.20m

Variant with scaffold tubes

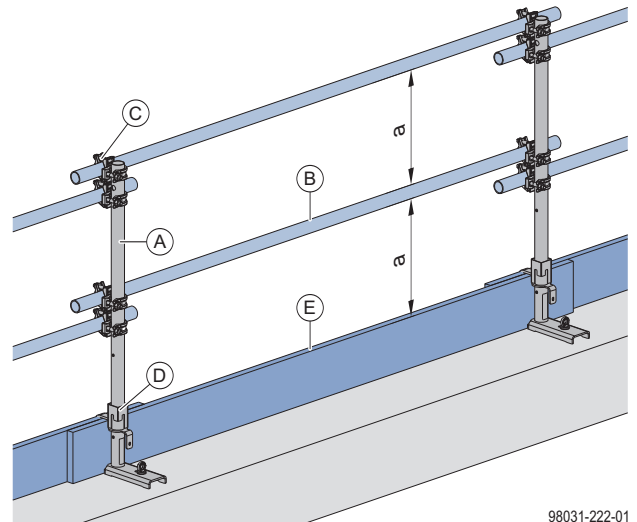

a ... max. 47.0 cm

- A** Handrail post Z 1.20m
- B** Scaffold tube 48.3mm
- C** Swivel coupler or Normal coupler 48mm
- D** Toeboard holder XP 0.60m
- E** Toeboard



- Use the Toeboard holder XP 0.60m for fastening the overlapping toeboard.
- Turn the safety bow of the Handrail post Z backwards.

Installing Handrail post XP and safety barrier

Installing the Handrail post XP

How to install, for example with the Handrail-post shoe XP:

- ▶ Secure the handrail-post shoe to the slab with Doka express anchor 16x125mm and Doka coil 16mm.
- ▶ Push on the Handrail post XP until it locks.

Practical example:

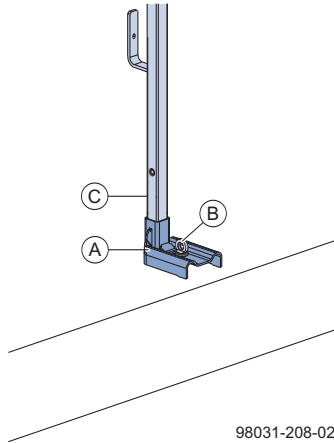

- A Handrail-post shoe XP
- B Doka express anchor 16x125mm
- C Handrail post XP 1.20m

Installing the safety barriers

with Handrail post XP 1.20m

- ▶ Hang the Protective barrier Z 1.20m into place in all 4 railing shackles.

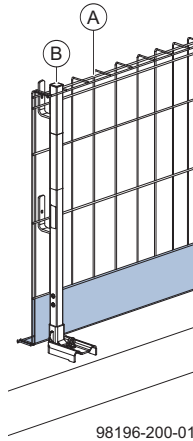

- A Protective barrier Z 2.50x1.20m or 1.25x1.20m
- B Handrail post XP 1.20m

with Handrail post XP flex 1.60m

with Railing holder XP flex



For detailed information about the Handrail post XP flex 1.60m and Railing holder XP flex see the 'Xsafe edge protection XP' User Information booklet.

- ▶ Install the Railing holder XP flex.

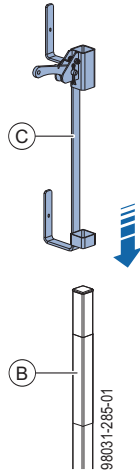

- B** Handrail post XP flex 1.60m
- C** Railing holder XP flex

- ▶ Hang the Protective barrier Z 1.20m into place in all 4 railing shackles.

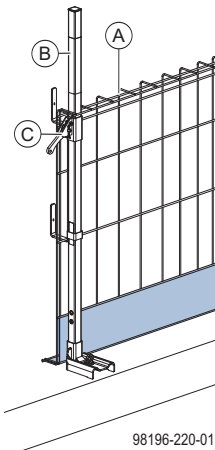

- A** Protective barrier Z 2.50x1.20m or 1.25x1.20m
- B** Handrail post XP flex 1.60m
- C** Railing holder XP flex

with Toeboard holder XP 1.20m



For detailed information about the Handrail post XP flex 1.60m and Toeboard holder XP see the 'Xsafe edge protection XP' User Information booklet.

- ▶ Install the Toeboard holder XP 1.20m.

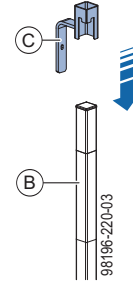

- B** Handrail post XP flex 1.60m
- C** Toeboard holder XP 1.20m

- ▶ Engage the Protective barrier Z 1.20m from above and allow the Toeboard holder XP 1.20m to slide down.

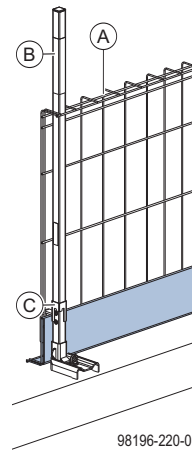

- A** Protective barrier Z 2.50x1.20m or 1.25x1.20m
- B** Handrail post XP flex 1.60m
- C** Toeboard holder XP 1.20m

Practical examples

Protective barrier Z 2.50x1.20m

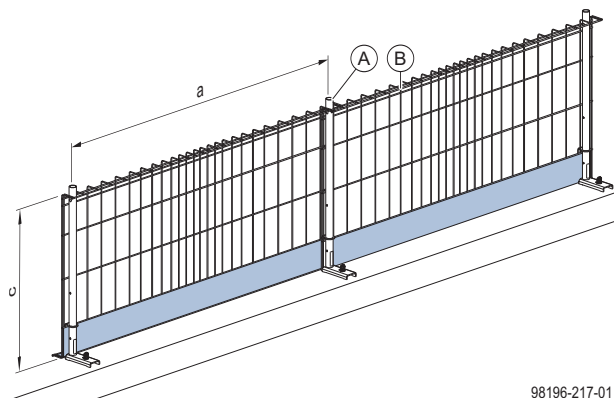

a ... spacing (span) between handrail posts max. 2.40 m
c ... railing height 1.17 m

- A** Handrail post Z 1.20m,
Handrail post XP 1.20m,
Handrail post XP flex 1.60m with Handrail post XP flex,
Handrail post XP flex 1.60m with Toeboard holder XP
- B** Protective barrier Z 2.50x1.20m

Protective barrier Z 1.25x1.20m

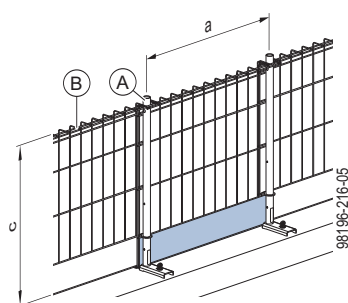

a ... spacing (span) between handrail posts max. 1.15 m
c ... railing height 1.17 m

- A** Handrail post Z 1.20m,
Handrail post XP 1.20m,
Handrail post XP flex 1.60m with Handrail post XP flex,
Handrail post XP flex 1.60m with Toeboard holder XP
- B** Protective barrier Z 1.25x1.20m

Structural design

General notes on structural design

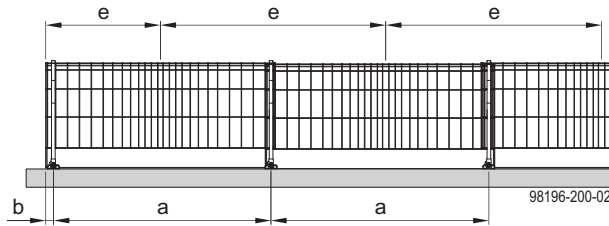

a ... span
 b ... cantilever
 e ... influence width



NOTICE

A fundamental distinction must be made between the span (**a**) and the influence width (**e**):

- The span is the distance between the hand-rail posts.
- The permitted influence width of a handrail post is stated in the respective tables.
- The actual influence width can only be determined by calculation, and corresponds to roughly the spacing 'a' between the hand-rail posts, and in the cantilever-arm zone to around $b + a/2$.



- The span (**a**) of the handrail posts is roughly equal to the influence width (**e**) if
 - they are evenly spaced,
 - there are no cantilevering projections.
- The wind conditions likely to be encountered in Europe, in accordance with EN 13374, are largely recognised by the peak velocity pressure $q=0.6 \text{ kN/m}^2$.
- An aerodynamic coefficient $c_f = 1.3$ was taken into consideration in calculation of the permissible influence widths.

Permitted cantilever (b) of edge-protection components

Edge-protection component	Permitted cantilever			
	Dynamic pressure q [kN/m ²]			
	0.2	0.6	1.1	1.3
Protective barrier Z 2.50x1.20m	0.55 m	0.55 m	0.35 m	0.10 m
Scaffold tube 48.3mm	1.30 m			

Anchoring with Doka express anchor 16x125mm or with alternative anchor-bolt (diam. 12 mm)

Characteristic cube compressive strength ($f_{ck, \text{cube}}$):
 $\geq 10 \text{ N/mm}^2$

Distance of anchorage point from edge: min. 15 cm

Peak velocity pressure q [kN/m ²]	Permissible influence width 'e' [m]		
	Protective barrier Z 2.50x1.20m ¹⁾	Protective barrier Z 1.25x1.20m ¹⁾	Scaffold tubes 48.3mm ²⁾
0.2	2.4	1.15	5.0
0.6			4.7
1.1	1.2		4.8
1.3			4.1

¹⁾ with toeboard 3 x 20 cm, 4 x 20 cm or 5 x 20 cm
²⁾ with toeboard 5 x 20 cm

Actual tensile force in the Doka express anchor:
 $F_{Ed} = 6.9 \text{ kN}$ ($F_{perm.} = 4.6 \text{ kN}$)



Required load-bearing capacity of alternative anchor-bolts:

$F_{Ed} = 6.3 \text{ kN}$ ($F_{perm.} = 4.2 \text{ kN}$)

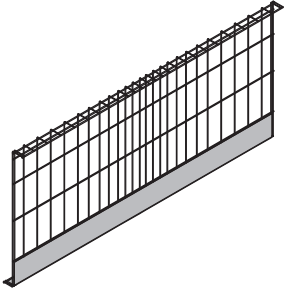
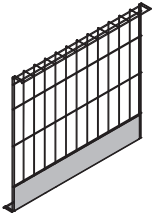
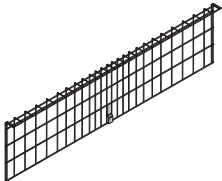

Follow the manufacturers' applicable fitting instructions.

Edge protection - railing height up to 1.80 m

Safety barriers

Protective barrier Z 2.50x1.20m	Protective barrier Z 1.25x1.20m
	
Protective barrier Z 2.50x0.60m	Protective barrier Z 1.25x0.60m
	
Scaffold tube 48.3mm	

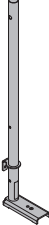
Handrail post Z

Handrail post Z 1.20m	Handrail post Z 0.60m
	

Extending height of edge protection to barrier height 1.80 m

Xsafe edge protection Z with railing height 1.20 m already installed (see the section headed [Installing Handrail post Z 1.20m and safety barrier](#)).

- ▶ Use the safety plate to fix the Protective barrier Z 0.60m to the bottom Protective barrier Z 1.20m.

Installing the Handrail post Z 0.60m

- ▶ Push Handrail post Z 0.60m down on to Handrail post Z 1.20m until the locking pin engages.

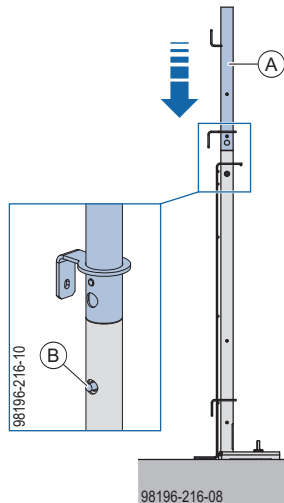

A Handrail post Z 0.60m

B Locking pin



- The locking pin must engage.
- The railing shackles must be facing towards the inside of the building.

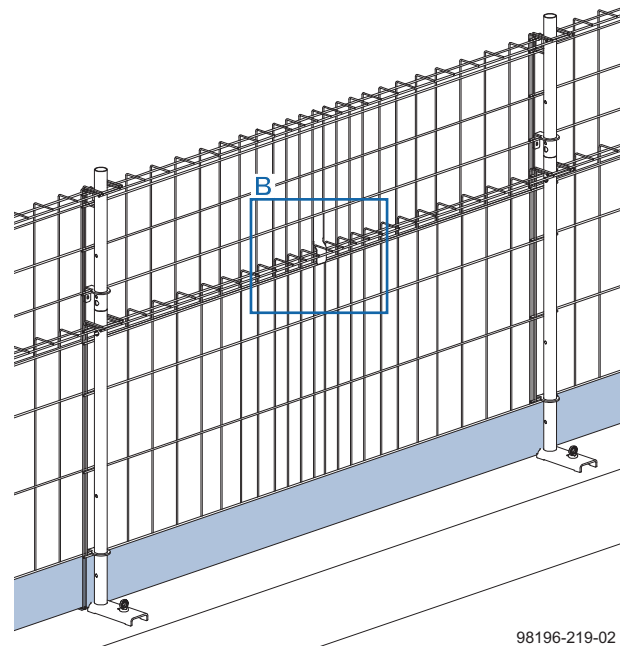

Close-up B

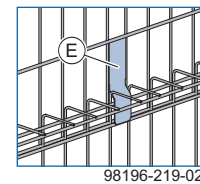

E Safety plate



Safety plate must overlap.

Installing the safety barriers

Installing the Protective barrier Z 0.60m

- ▶ Push the safety bow of the Handrail post Z 0.60m upwards until it hits the stop.
- ▶ Engage the Protective barrier Z 0.60m from above and allow the safety bow to slide down.

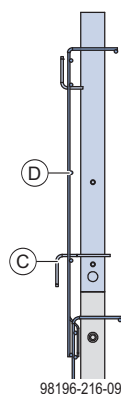

C Safety bow of Handrail post Z 0.60m

D Protective barrier Z 0.60m

Variant with scaffold tubes

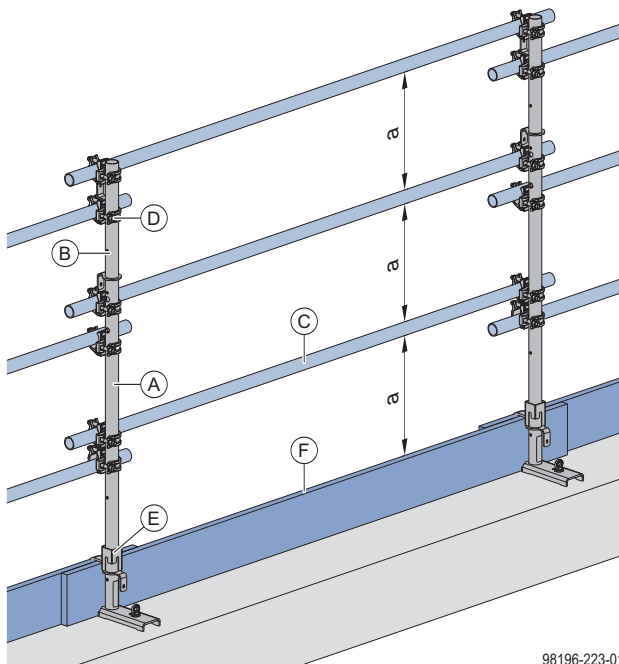

a ... max. 47.0 cm

- A** Handrail post Z 1.20m
- B** Handrail post Z 0.60m
- C** Scaffold tube 48.3mm
- D** Swivel coupler or Normal coupler 48mm
- E** Toeboard holder XP 0.60m
- F** Toeboard



- Use the Toeboard holder XP 0.60m for fastening the overlapping toeboard.
- Turn the safety bow of the Handrail post Z backwards.

Structural design

General notes on structural design

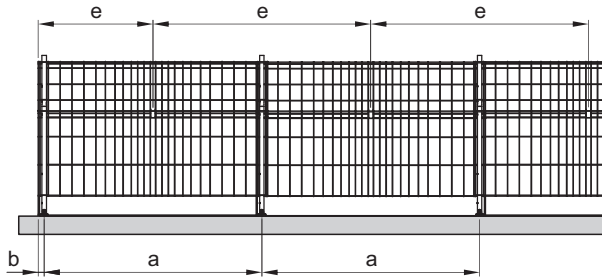

98196-219-01

a ... span
b ... cantilever
e ... influence width



NOTICE

A fundamental distinction must be made between the span (**a**) and the influence width (**e**):

- The span is the distance between the handrail posts.
 - The permitted influence width of a handrail post is stated in the respective tables.
 - The actual influence width can only be determined by calculation, and corresponds to roughly the spacing 'a' between the handrail posts, and in the cantilever-arm zone to around $b + a/2$.
- The span (**a**) of the handrail posts is roughly equal to the influence width (**e**) if
- they are evenly spaced,
 - the guardrail boards are either continuous or are jointed at the handrail posts, and
 - there are no cantilevering projections.
- The wind conditions likely to be encountered in Europe, in accordance with EN 13374, are largely recognised by the peak velocity pressure $q=0.6 \text{ kN/m}^2$ (highlighted grey in the tables).
- An aerodynamic coefficient $c_f = 1.3$ was taken into consideration in calculation of the permissible influence widths.



Permitted cantilever (b) of edge-protection components

Edge-protection component	Permitted cantilever			
	Peak velocity pressure q [kN/m ²]			
	0.2	0.6	1.1	1.3
Protective barrier Z 2.50x1.20m	0.55 m	0.55 m	0.35 m	0.10 m
Scaffold tube 48.3mm	1.30 m			

Anchoring with Doka express anchor 16x125mm or with alternative anchor-bolt (diam. 12 mm)

Characteristic cube compressive strength ($f_{ck, \text{cube}}$):
 $\geq 10 \text{ N/mm}^2$

Distance of anchorage point from edge: min. 15 cm

Peak velocity pressure q [kN/m ²]	Permissible influence width 'e' [m]		
	Protective barrier Z ¹⁾ 2.50x1.20m and 2.50x0.60m	Protective barrier Z ¹⁾ 1.25x1.20m and 1.25x0.60m	Scaffold tubes 48.3mm ²⁾
0.2	2.4	1.15	4.2
0.6			3.0
1.1	1.2		2.5
1.3			

¹⁾ with toeboard 3 x 20 cm, 4 x 20 cm or 5 x 20 cm

²⁾ with toeboard 5 x 20 cm

Actual tensile force in the Doka express anchor:
 $F_{Ed} = 13.5 \text{ kN}$ ($F_{perm.} = 9.0 \text{ kN}$)

Required load-bearing capacity of alternative anchor-bolts:

$F_{Ed} = 12.4 \text{ kN}$ ($F_{perm.} = 8.3 \text{ kN}$)

Follow the manufacturers' applicable fitting instructions.

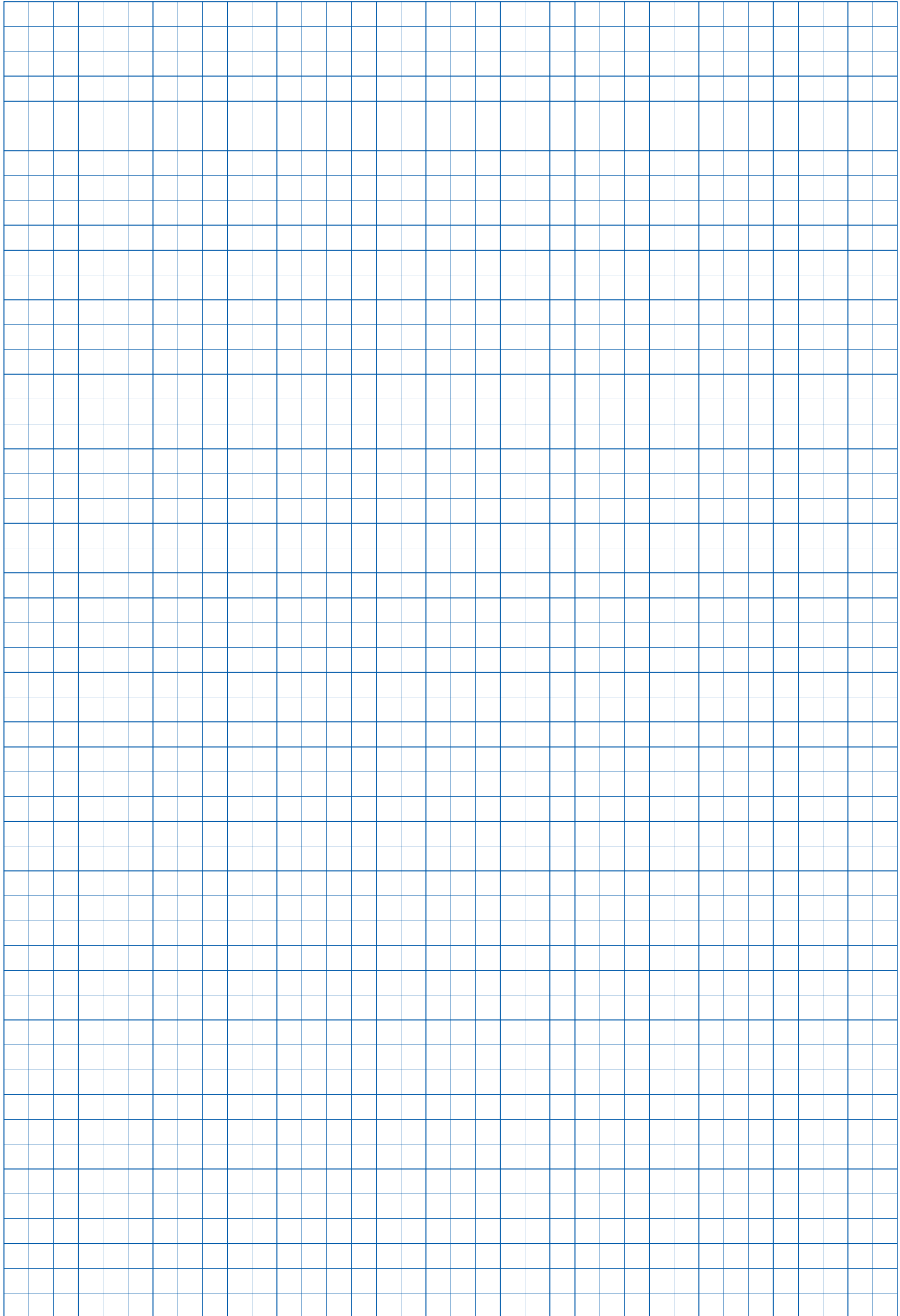

General

Individual design options

Mounting advertising signboards

Advertising signboards can be attached to the Protective barrier Z on-site.



NOTICE

- It is only allowed to fit signboards to 1.20 m high Protective barriers Z.
- Size of signboard (width x height): max. 1.50x1.00m (1.50 m²)
- Max. distance between posts: 1.20 m
- Dynamic pressure q: max. 0.6 kN/m²
- Mounting signboards on two adjacent Protective barriers Z is not allowed (must be spaced at least one barrier apart).
- Fasten the signboard to the Protective barrier Z centrally, using cable ties.
 - Tie it 4x at the top, 6x in the middle and 4x at the bottom (only applies to signboards measuring 1.50x1.00m).
- The holes for fixing the signboard must be drilled on-site.
- Vertical stacking with Protective barrier Z 0.60m is still possible.
- The stacking height will depend on how thick the advertising signboard is.
- When the signboards are stacked, some of them may end up being scratched.



Alternatively, advertising nets or tarpaulins can also be attached (attachment method will depend on the type of net or tarp).

Practical example

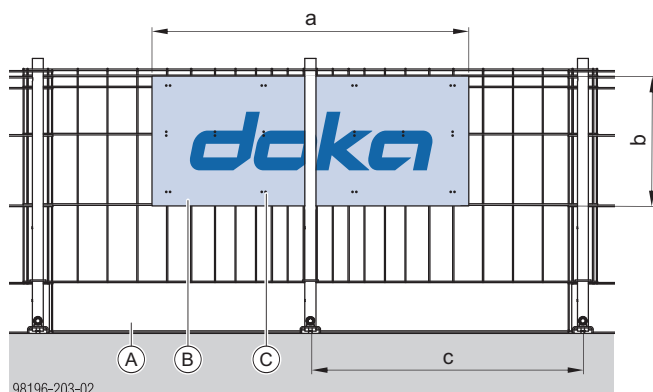

- a ... 150 cm
 b ... 100 cm
 c ... max. 120 cm

A Protective barrier Z 2.50x1.20m

B Advertising signboard 1.50x1.00m

C Fixing points for cable ties (width min. 4.6 mm)

Colour scheme and customer logo

- Protective barriers Z can be ordered in various colours **(A)** (all RAL colours possible). They are powder-coated in a single colour.
- On request, the empty area of the toeboard can also be used for affixing customer stickers **(B)**.

For more information, please contact your Doka technician.

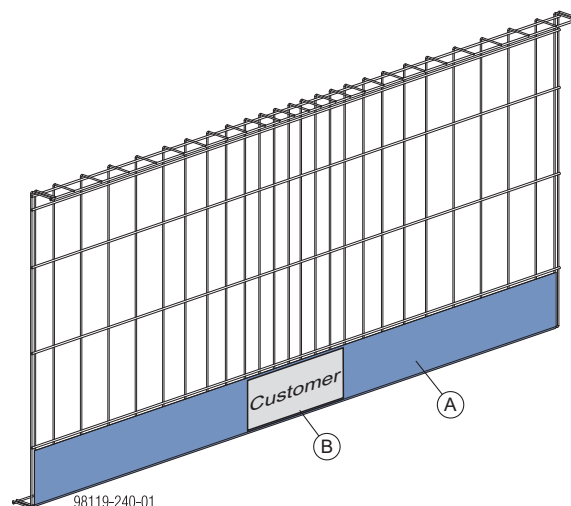

Transporting, stacking and storing

Utilise the benefits of Doka multi-trip packaging on your site.

Multi-trip packaging such as containers, stacking pallets and skeleton transport boxes keep everything in place on the site, minimise time wasted searching for parts, and streamline the storage and transport of system components, small items and accessories.

Protective barrier Z pallet

Protective barrier Z pallet 1.20m

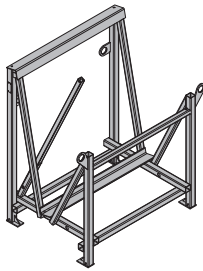

Features:

- Safe storage and transport pallet for up to 70 Protective barriers Z 2.50x1.20m or 1.25x1.20m.
- Removable shaped tube for securing the Protective barriers Z in position.
- Compatible with Bolt-on castor set B.

Permitted load-bearing capacity: 1080 kg (2380 lbs)



NOTICE

- The type plate must be in place and clearly legible.

Protective barrier Z pallet 0.60m

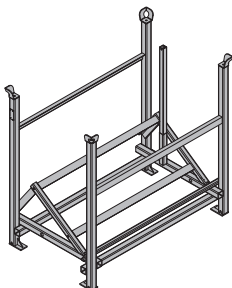

Features:

- Safe storage and transport pallet for up to 65 Protective barriers Z 2.50x0.60m or 1.25x0.60m.
- Removable shaped tube for securing the Protective barriers Z in position.
- Compatible with Bolt-on castor set B.

Permitted load-bearing capacity: 530 kg (1168 lbs)

Permitted imposed stacking load: 602 kg (1327 lbs)



NOTICE

- The type plate must be in place and clearly legible.

Loading Protective barrier Z pallet

Loading, Protective barrier Z 1.20m as example:

- ▶ Centre the Protective barriers Z on the pallet, set alternately right way up and upside down.

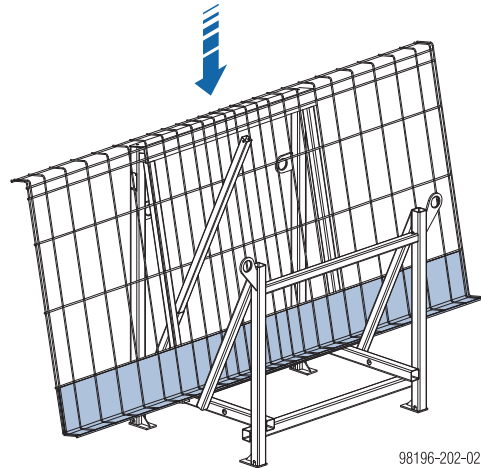

98196-202-02

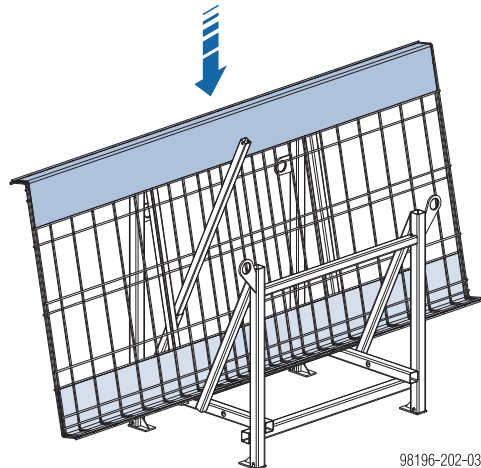

98196-202-03



The shaped tube (A) can be removed to facilitate loading and unloading of the protective barriers. When loading, make sure that the protective barriers are all stacked exactly on top of each other so that the shaped tube can be inserted into the opening created in this way.

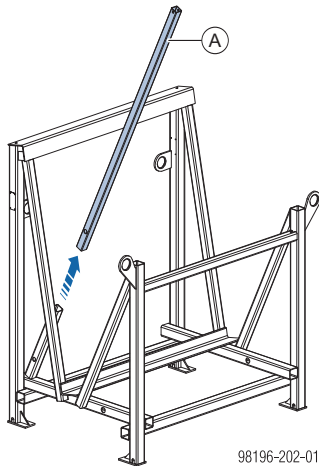

Practical examples

Protective barrier Z 1.20m

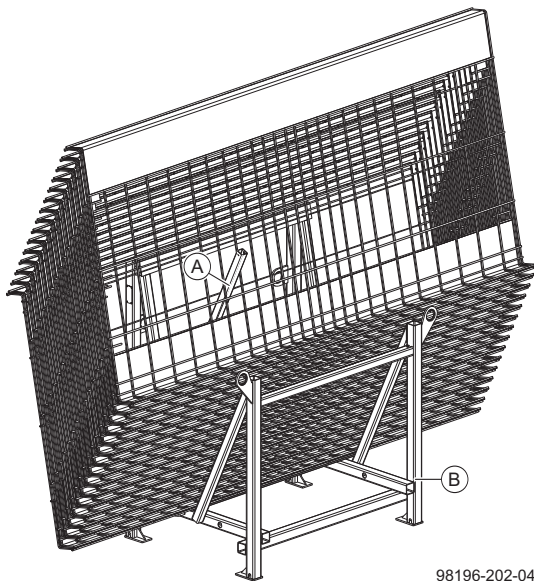

- A Shaped tube
- B Protective barrier Z pallet 1.20m

Protective barrier Z 0.60m

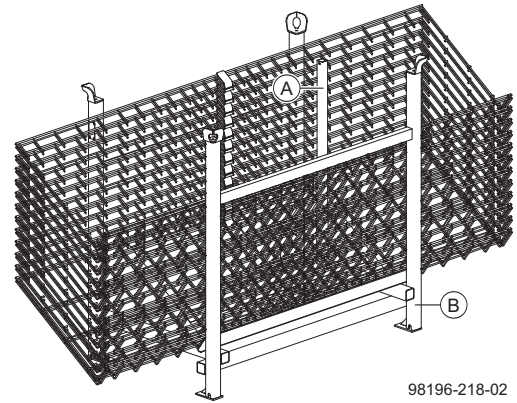

- A Shaped tube
- B Protective barrier Z pallet 0.60m

Protective barrier Z pallet as storage pallet



NOTICE

- Do **not** stack Protective barrier Z pallets 1.20m on top of each other.
- One more pallet can be placed on top of the pallet of Protective barriers Z 0.60m.
- If wind speeds are high (storm wind), set two pallets tight beside each other or secure the single pallets, for example with tie-backs.
- How to use with bolt-on castor set:
 - Always apply the fixing brake when the pallet is 'parked'.

Protective barrier Z pallet as transport pallet

Lifting by crane



NOTICE

- Load the items centrally.
- Reposition the pallet only with the shaped tube correctly installed.
- Use a suitable crane lifting tackle (e.g. Doka 4-part chain 3.20m). Do not exceed the permitted working load limit.
- Sling angle β max. 30° .
- Attach the lifting tackle only to the crane lifting points provided for the purpose.
- Reposition only one pallet at a time.

Protective barrier Z 1.20m

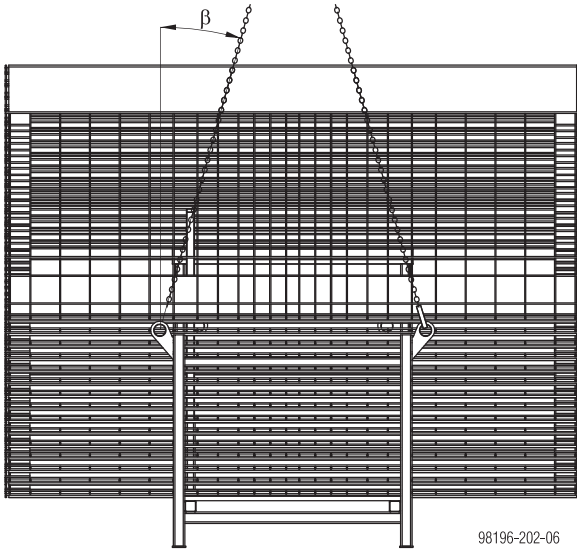

Protective barrier Z 0.60m

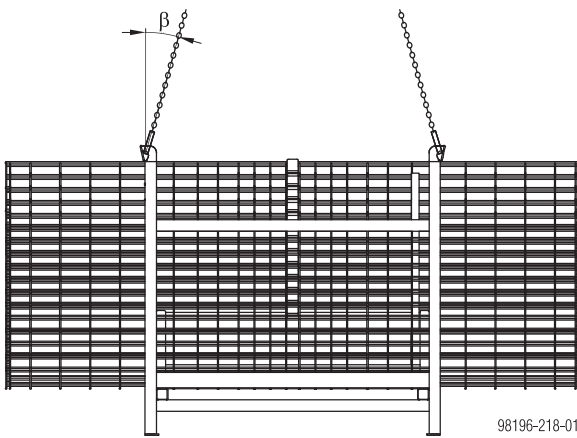

- Before repositioning, check that the lifting tackle is correctly attached at all points.

Repositioning by forklift truck or pallet stacking truck



NOTICE

- Load the items centrally.
- Reposition the pallet only with the shaped tube correctly installed.
- Secure the Protective barriers Z to the pallet in such a way that they cannot slide or tip.

Transport by truck



- Reposition the pallet only with the shaped tube correctly installed.
- When loading pallets on to a truck, make sure that the Protective barriers Z are all inclined in the same direction. This leaves all the crane slinging points easily accessible.
- By preference, load the pallets lengthways to the truck's cargo bed. Arranged in this way, there is room for 3 pallets side by side.

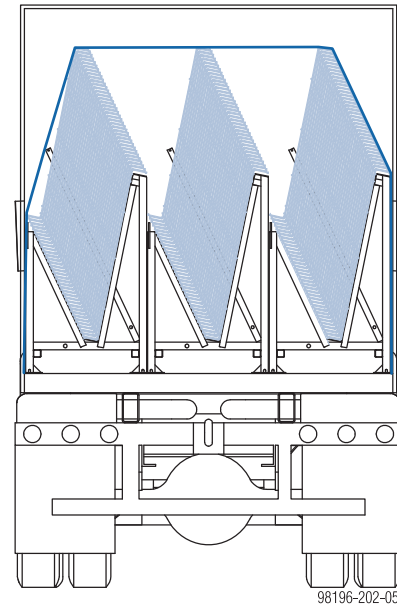

Doka skeleton transport box 1.70x0.80m

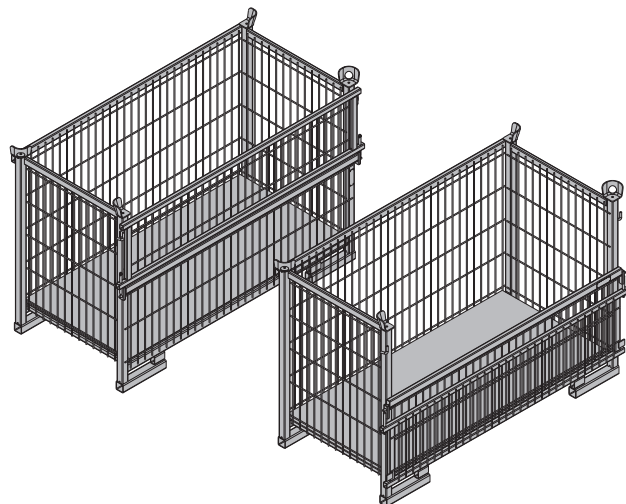

Storage and transport device for small items. To make the Doka skeleton transport box easier to load and unload, one of its sidewalls can be opened.

Permitted load-bearing capacity: 700 kg (1540 lbs)
 Permitted imposed stacking load: 3150 kg (6950 lbs)

Using Doka skeleton transport boxes 1.70x0.80m as storage units

Max. n° of units on top of one another

Outdoors (on the site) Floor gradients up to 3%	Indoors Floor gradients up to 1%
2	5
It is not allowed to stack empty pallets on top of one another!	



NOTICE

Stacked multi-trip boxes or pallets must have the heaviest boxes at the bottom and the lightest at the top.

Using Doka skeleton transport boxes 1.70x0.80m as transport devices

Lifting by crane



NOTICE

- Multi-trip packaging items must be lifted individually.
- Only lift the boxes when their sidewalls are closed!
- Use suitable lifting chains:
 - e.g. Doka 4-part chain 3.20m
 - Do not exceed the permitted working load limit of the lifting chains.
- Sling angle β max. 30°!

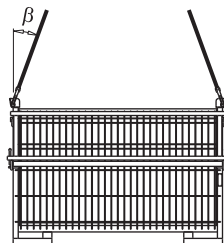

9234-203-01

Repositioning by forklift truck or pallet stacking truck

The forks can be inserted under either the broadside or the narrowside of the containers.

Doka multi-trip transport box

Storage and transport device for small items

Doka multi-trip transport box 1.20x0.80m

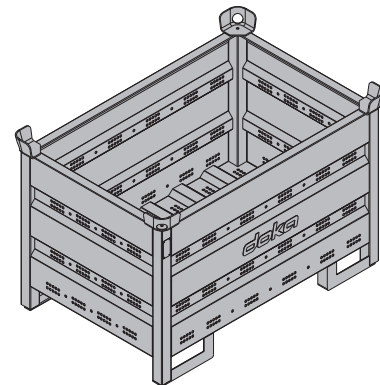

Permitted load-bearing capacity: 1500 kg (3300 lbs)
Permitted imposed stacking load: 7850 kg (17300 lbs)

Different items in the Doka multi-trip transport box can be kept separate with the **Multi-trip transport box partitions 1.20m or 0.80m**.

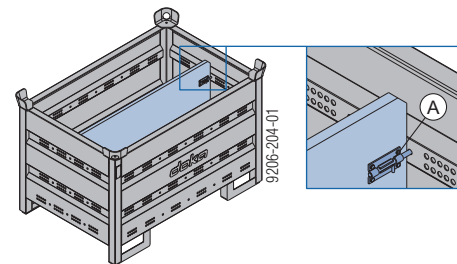

A Slide-bolt for fixing the partition

Possible ways of dividing the box

Multi-trip transport box partition	in the longitudinal direction	in the transverse direction
1.20m	max. 3	-
0.80m	-	max. 3

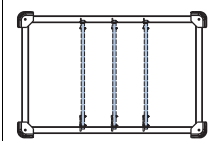
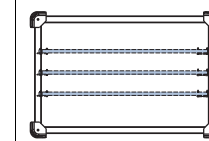

Doka multi-trip transport box 1.20x0.80mx0.41m

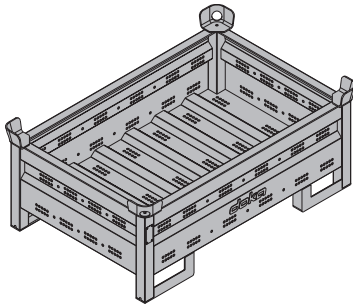

Permitted load-bearing capacity: 750 kg (1650 lbs)
Permitted imposed stacking load: 7200 kg (15870 lbs)

Using Doka multi-trip transport boxes as storage units

Max. n° of units on top of one another

Outdoors (on the site) Floor gradients up to 3%		Indoors Floor gradients up to 1%	
Doka multi-trip transport box 1.20x0.80m		Doka multi-trip transport box 1.20x0.80m	
Doka multi-trip transport box 1.20x0.80x0.41m		Doka multi-trip transport box 1.20x0.80x0.41m	
3	5	6	10
It is not allowed to stack empty pallets on top of one another!			



NOTICE

Stacked multi-trip boxes or pallets must have the heaviest boxes at the bottom and the lightest at the top.

Using Doka multi-trip transport boxes as transport devices

Lifting by crane



NOTICE

- Multi-trip packaging items must be lifted individually.
- Use suitable lifting chains:
 - e.g. Doka 4-part chain 3.20m
 - Do not exceed the permitted working load limit of the lifting chains.
- Sling angle β max. 30°!

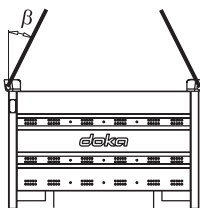

9206-202-01

Repositioning by forklift truck or pallet stacking truck

The forks can be inserted under either the broadside or the narrowside of the containers.

Bolt-on castor set B

The Bolt-on castor set B turns multi-trip packaging items into fast and manoeuvrable transport devices. Suitable for drive-through access openings > 90 cm.

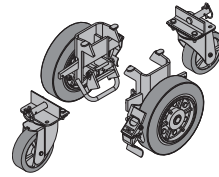









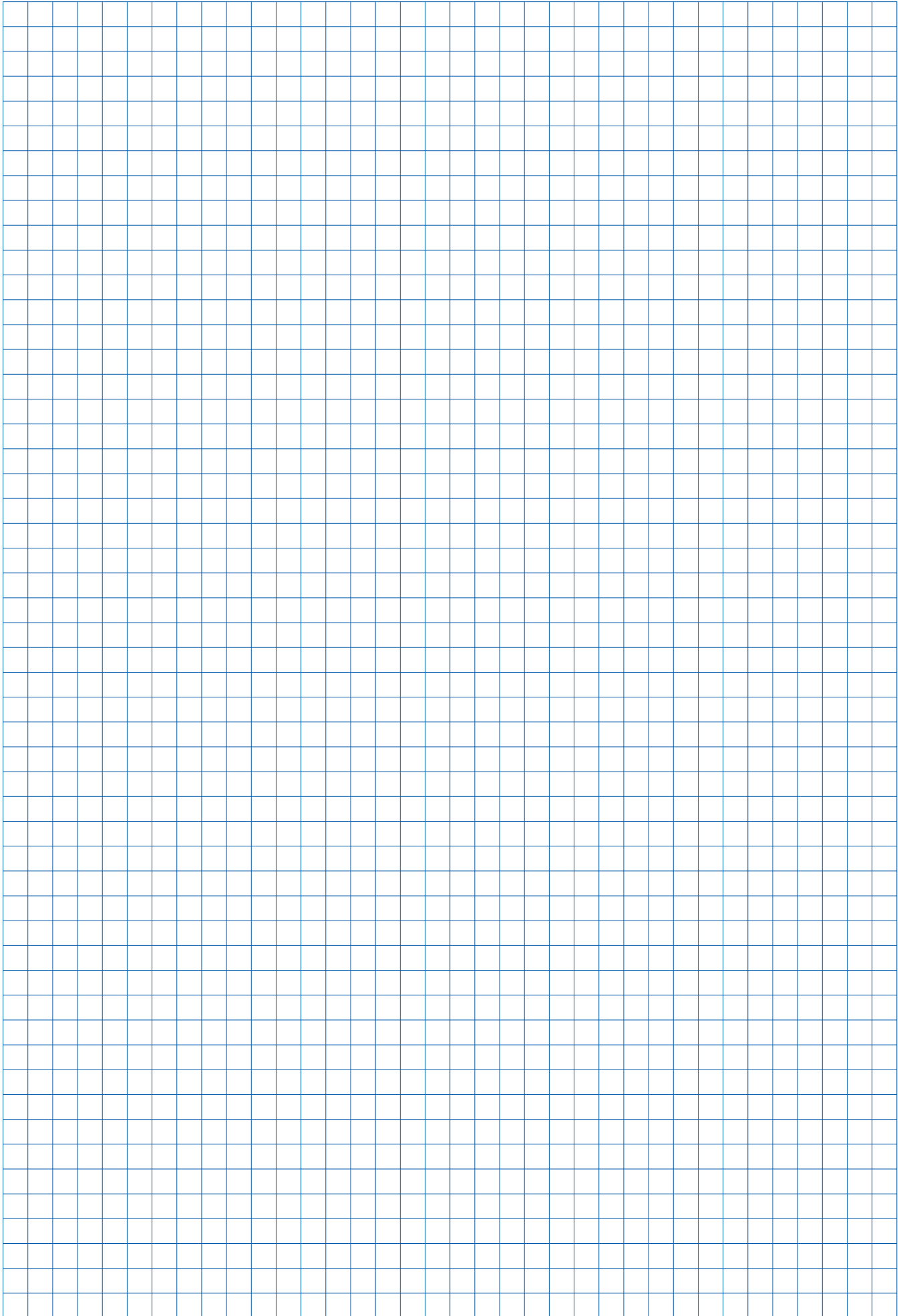

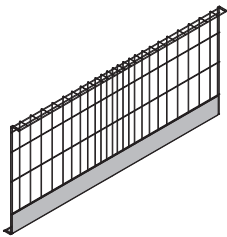
The Bolt-on castor set B can be mounted to the following multi-trip packaging items:

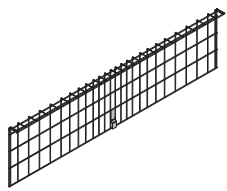



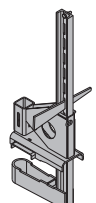

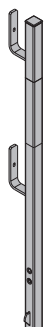

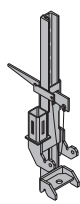
- Doka accessory box
- Doka stacking pallets
- Protective barrier Z pallets

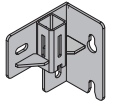
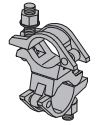

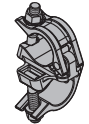
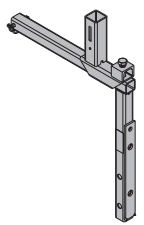
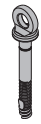

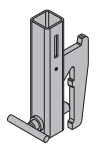
Follow the directions in the 'Bolt-on castor set B' User Information booklet!

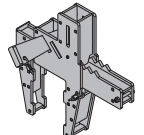

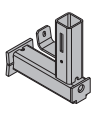
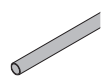
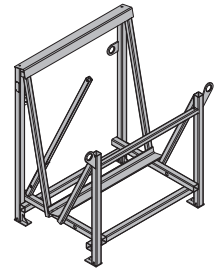
	[kg]	Article N°		[kg]	Article N°
Protective barrier Z 2.50x1.20m Protective barrier Z 1.25x1.20m Schutzgitter Z 	13.3 7.3	586642000 586643000	Powder-coated blue		
Handrail post XP flex 1.60m Geländersteher XP flex 1,60m 			Galvanised	4.8	586494000
Protective barrier Z 2.50x0.60m Protective barrier Z 1.25x0.60m Schutzgitter Z 	7.4 3.9	586644000 586645000	Powder-coated blue		
Railing holder XP flex Geländerhalter XP flex 			Galvanised Height: 66.6 cm	2.5	586495000
Handrail post Z 1.20m Geländersteher Z 1,20m 	5.0	586640000	Galvanised		
Handrail-post shoe XP Geländerschuh XP 			Galvanised Length: 20 cm	2.2	586457000
Railing clamp XP 40cm Geländerzwinde XP 40cm 			Galvanised Height: 73 cm	7.7	586456000
Handrail post Z 0.60m Geländersteher Z 0,60m 	2.5	586641000	Galvanised		
Railing clamp XP 85cm Geländerzwinde XP 85cm 			Galvanised Height: 115 cm	9.3	586468000
Handrail post XP 1.20m Geländersteher XP 1,20m 	4.1	586460000	Galvanised Height: 118 cm		
Screw-on shoe XP Schraubschuh XP 			Galvanised Height: 27 cm	1.5	586458000
Toeboard holder XP 1.20m Fußwehrhalter XP 1,20m 	0.64	586461000	Galvanised Height: 21 cm		
Bridge-deck clamp XP Tragwerkzwinde XP 			Galvanised Height: 68 cm	7.4	586465000

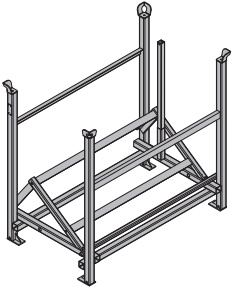
	[kg]	Article N°		[kg]	Article N°
Multi precast connector XP Multi-Fertigteileanschluss XP  Galvanised Height: 20 cm	3.0	586493000	Swivel coupler 48mm Drehkupplung 48mm  Galvanised Width-across: 22 mm	1.5	582560000
Parapet adapter XP Brüstungsadapter XP  Galvanised Height: 17 cm	2.9	586469000	Normal coupler 48mm Normalkupplung 48mm  Galvanised Width-across: 22 mm	1.2	682004000
Parapet bracket XP Attikakonsole XP  Galvanised Length: 48.5 cm Height: 67.5 cm	6.0	586488000	Doka express anchor 16x125mm Doka-Expressanker 16x125mm  Galvanised Length: 18 cm	0.31	588631000
Weld-on connecting piece XP Anschweißstützen XP  Non-treated Height: 16 cm	0.81	586467000	Doka coil 16mm Doka-Coil 16mm  Galvanised Diameter: 1.6 cm	0.009	588633000
Sheet pile adapter XP Spundwandadapter XP  Galvanised Length: 11 cm Width: 10 cm Height: 29 cm	2.6	586484000	Information plate for express anchor Plakette Expressanker  PS Width: 8 cm Height: 7.5 cm	0.1	588630000
Trench box adapter XP Verbauplattenadapter XP  Galvanised Length: 32 cm	6.5	586492000	Doka 4-part chain 3.20m Doka-Vierstrangkette 3,20m  Follow the directions in the "Operating Instructions"!	15.0	588620000
Balcony adapter XP Balkonadapter XP  Galvanised Length: 20.9 cm Width: 8.0 cm Height: 22.1 cm	2.4	586485000	Multi-trip packaging		
Scaffold tube 48.3mm 0.50m Scaffold tube 48.3mm 1.00m Scaffold tube 48.3mm 1.50m Scaffold tube 48.3mm 2.00m Scaffold tube 48.3mm 2.50m Scaffold tube 48.3mm 3.00m Scaffold tube 48.3mm 3.50m Scaffold tube 48.3mm 4.00m Scaffold tube 48.3mm 4.50m Scaffold tube 48.3mm 5.00m Scaffold tube 48.3mm 5.50m Scaffold tube 48.3mm 6.00m Gerüstrohr 48,3mm  Galvanised	1.7 3.6 5.4 7.2 9.0 10.8 12.6 14.4 16.2 18.0 19.8 21.6 3.6	682026000 682014000 682015000 682016000 682017000 682018000 682019000 682021000 682022000 682023000 682024000 682025000 682001000	Protective barrier Z pallet 1.20m Palette Schutzgitter Z 1,20m  Galvanised Length: 106 cm Width: 80 cm Height: 149 cm	72.6	586646000

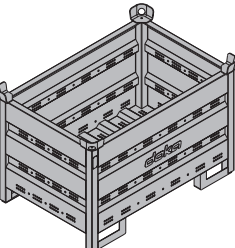
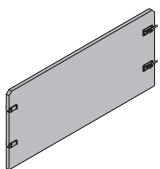
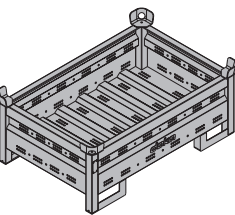
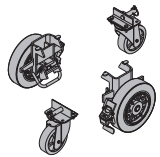
	[kg]	Article N°	[kg]	Article N°
<p>Protective barrier Z pallet 0.60m Palette Schutzgitter Z 0,60m</p>  <p>Galvanised Length: 134.4 cm Width: 82.4 cm Height: 127.6 cm</p>	71.4	586647000		
<p>Doka skeleton transport box 1.70x0.80m Doka-Gitterbox 1,70x0,80m</p>  <p>Galvanised Height: 113 cm</p>	87.0	583012000		
<p>Doka multi-trip transport box 1.20x0.80m Doka-Mehrwegcontainer 1,20x0,80m</p>  <p>Galvanised Height: 78 cm</p>	70.0	583011000		
<p>Multi-trip transport box partition 0.80m Multi-trip transport box partition 1.20m Mehrwegcontainer Unterteilung</p>  <p>Steel parts galvanised Timber parts varnished yellow</p>	3.7 5.5	583018000 583017000		
<p>Doka multi-trip transport box 1.20x0.80x0.41m Doka-Mehrwegcontainer 1,20x0,80x0,41m</p>  <p>Galvanised</p>	42.5	583009000		
<p>Bolt-on castor set B Anklemm-Radsatz B</p>  <p>Painted blue</p>	33.6	586168000		



Formwork & Scaffolding.
We make it work.
