

Framed formwork Framax Xlife plus

User Information

Instructions for assembly and use (Method statement)

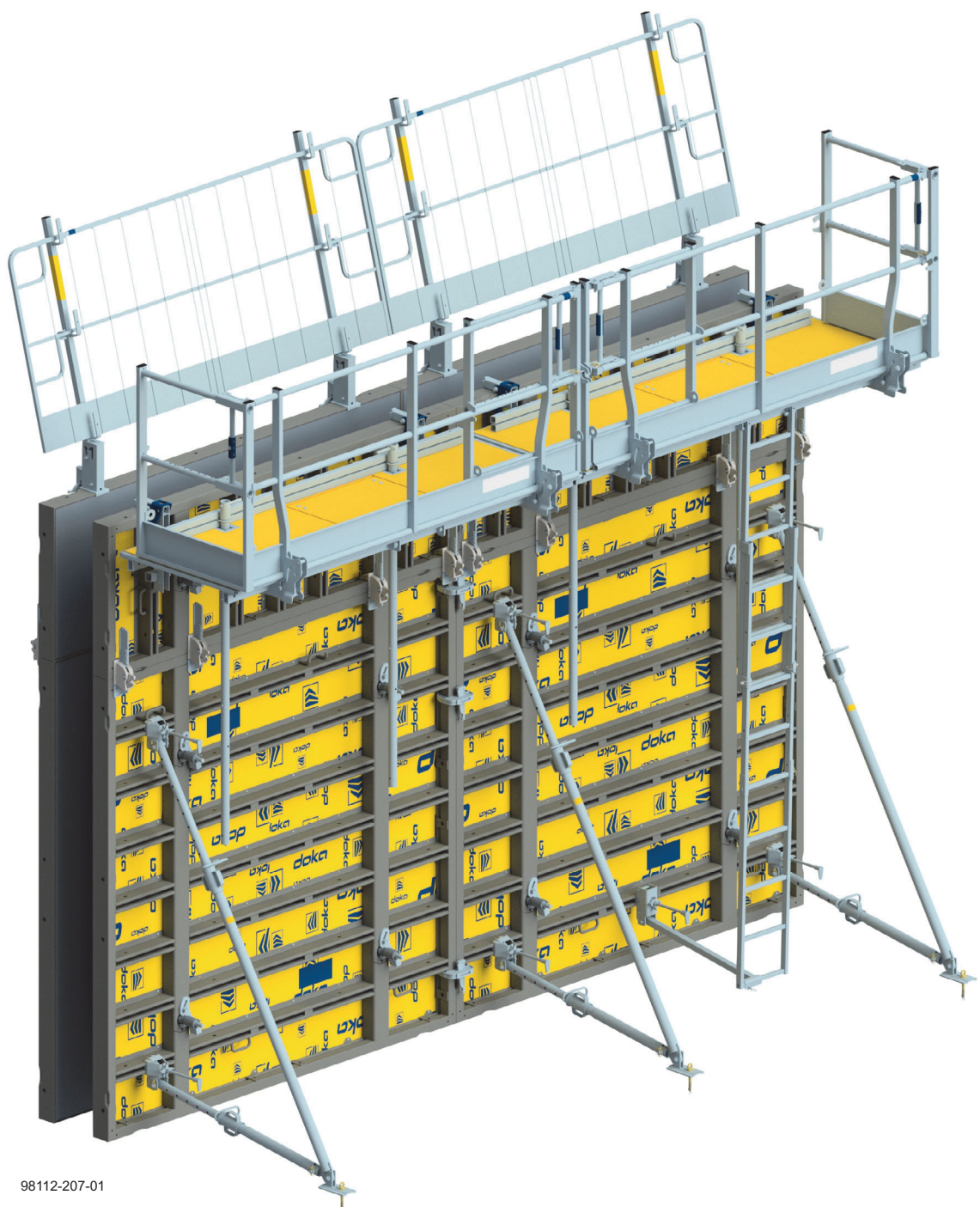

Contents

4 Introduction

- 4 Elementary safety warnings
- 8 Intended use

9 Wall formwork

- 10 Instructions for assembly and use for room-high formwork
- 14 Instructions for assembly and use for high formwork
- 18 Framax Xlife plus panel in detail
- 20 System grid
- 22 Inter-panel connections
- 25 Panel bracing with Framax universal waling
- 28 Vertical stacking of panels
- 54 Tie rod system Framax Xlife plus
- 67 Length adjustment using closures
- 69 90 degree corners
- 83 Acute & obtuse-angled corners
- 89 Shaft formwork
- 100 Inter-panel connections for increased tensile loads
- 101 Stop-end formwork
- 104 Wall junctions, offsets and steps
- 110 Wall thickness >45 and up to 60 cm
- 113 Window and door openings
- 114 Plumbing accessories
- 118 Pouring platforms
- 124 Pouring platforms with single brackets
- 140 Opposing guardrail
- 143 Wall formwork at the edge of the structure
- 151 Ladder system
- 155 Tools for plumbing and aligning and for stripping the formwork
- 157 Lifting by crane
- 160 Transporting, stacking and storing

167 General

- 167 Areas of use
- 168 Framax Xlife plus combined with . . .
- 170 Cleaning and care of your equipment
- 173 Fall protection on the structure

174 Article list

Introduction

Elementary safety warnings

User target groups

- This booklet is aimed at all persons who will be working with the Doka product or system that it describes. It contains information on the standard design for setting up this system, and on correct, compliant utilisation of the system.
- All persons working with the product described herein must be familiar with the contents of this booklet and with all the safety instructions it contains.
- Persons who are incapable of reading and understanding this booklet, or who can do so only with difficulty, must be instructed and trained by the customer.
- The customer is to ensure that the information materials provided by Doka (e.g. User Information booklets, Instructions for Assembly and Use, Operating Instruction manuals, plans etc.) are up to date and available to all users, and that they have been made aware of them and have easy access to them at the usage location.
- In the relevant technical documentation and formwork utilisation plans, Doka shows the workplace safety precautions that are necessary in order to use the Doka products safely in the usage situations shown.
In all cases, users are obliged to ensure compliance with national laws, standards and regulations throughout the entire project and to take appropriate additional or alternative workplace safety precautions where necessary.

Hazard assessment

- The customer is responsible for drawing up, documenting, implementing and continually updating a hazard assessment at every job-site. This booklet serves as the basis for the site-specific hazard assessment, and for the instructions given to users on how to prepare and utilise the system. It does not substitute for these, however.

Remarks on this booklet

- This document can be used as general Instructions for Assembly and Use (Method Statement) or be incorporated into site-specific Instructions for Assembly and Use (Method Statement).
- **The graphics, animations and videos in this document or app sometimes depict partially assembled assemblies and may require additional safety equipment and/or measures to comply with safety regulations.**
The customer must ensure all applicable regulations are complied with, even if they are not shown or implied in the graphics, animations and videos provided.
- **Individual sections contain further safety instructions and/or special warnings as applicable.**

Planning

- Provide safe workplaces for those using the formwork (e.g. for when it is being erected/dismantled, modified or repositioned etc). It must be possible to get to and from these workplaces via safe access routes!
- **If you are considering any deviation from the details and instructions given in this booklet, or any application which goes beyond those described in the booklet, then revised static calculations must be produced for checking, as well as supplementary assembly instructions.**

Regulations; industrial safety

- All laws, Standards, industrial safety regulations and other safety rules applying to the utilisation of our products in the country and/or region in which you are operating must be observed at all times.
- If a person or object falls against, or into, the side-guard component and/or any of its accessories, the component affected may only continue in use after it has been inspected and passed by an expert.

Rules applying during all phases of the assignment

- The customer must ensure that this product is erected and dismantled, reset and generally used for its intended purpose in accordance with the applicable laws, standards and rules, under the direction and supervision of suitably skilled persons. These persons' mental and physical capacity must not in any way be impaired by alcohol, medicines or drugs.
- Doka products are technical working appliances which are intended for industrial / commercial use only, always in accordance with the respective Doka User Information booklets or other technical documentation authored by Doka.
- The stability and load-bearing capacity of all components and units must be ensured during all phases of the construction work!
- Do not step on or apply strain to cantilevers, closures, etc. until suitable measures to ensure their stability have been correctly implemented (e.g. by tie-backs).
- Strict attention to and compliance with the functional instructions, safety instructions and load specifications are required. Non-compliance can cause accidents and severe injury (risk of fatality) and considerable damage to property.
- Sources of fire in the vicinity of the formwork are prohibited. Heaters are permissible only when used correctly and situated a correspondingly safe distance from the formwork.
- Customer must give due consideration to any and all effects of the weather on the equipment and regards both its use and storage (e.g. slippery surfaces, risk of slipping, effects of the wind, etc.) and implement appropriate precautionary measures to secure the equipment and surrounding areas and to protect workers.
- All connections must be checked at regular intervals to ensure that they are secure and in full working order.
In particular threaded connections and wedged connections have to be checked and retightened as necessary in accordance with activity on the jobsite and especially after out-of-the-ordinary occurrences (e.g. after a storm).
- It is strictly forbidden to weld Doka products – in particular anchoring/tying components, suspension components, connector components and castings etc. – or otherwise subject them to heating.
Welding causes serious change in the microstructure of the materials from which these components are made. This leads to a dramatic drop in the failure load, representing a very great risk to safety.
It is permissible to cut individual tie rods to length with metal cutting discs (introduction of heat at the end of the rod only), but it is important to ensure that flying sparks do not heat and thus damage other tie rods.
The only articles which are allowed to be welded are those for which the Doka literature expressly points out that welding is permitted.

Assembly

- The equipment/system must be inspected by the customer before use, to ensure that it is in an acceptable condition. Steps must be taken to exclude components that are damaged, deformed, or weakened due to wear, corrosion or rot (e.g. fungal decay).
- Using our safety and formwork systems together with those of other manufacturers can create risks that may lead to injury and damage to property. This requires separate verification by the user.
- The equipment/system must be assembled and erected in accordance with the applicable laws, standards and rules by trained customer personnel whilst maintaining any applicable safety inspections that may be required.
- It is not permitted to modify Doka products; such modifications constitute a safety risk.

Closing the formwork

- Doka products and systems must be set up so that all loads acting upon them are safely transferred!

Pouring

- Do not exceed the permitted fresh-concrete pressures. Over-high pouring rates overload the formwork, cause greater deflection and risk breakage.

Stripping the formwork

- Do not strip out the formwork until the concrete has reached sufficient strength and the person in charge has given the order for the formwork to be stripped out!
- When stripping out the formwork, never use the crane to break concrete cohesion. Use suitable tools such as timber wedges, special pry-bars or system features such as Framax stripping corners.
- When stripping out the formwork, do not endanger the stability of any part of the structure, or of any scaffolding, platforms or formwork that is still in place!

Transporting, stacking and storing

- Observe all country-specific regulations applying to the handling of formwork and scaffolding. For system formwork the Doka slinging means stated in this booklet must be used – this is a mandatory requirement.

If the type of sling is not specified in this document, the customer must use slinging means that are suitable for the application envisaged and that comply with the regulations.

- When lifting, always make sure that the unit to be lifted and its individual parts can absorb the forces that occur.
- Remove loose parts or secure them so that they cannot slip out of position and drop.
- When lifting formwork or formwork accessories with a crane, no persons must be carried along, e.g. on working platforms or in multi-trip packaging.
- All components must be stored safely, following all the special Doka instructions given in the relevant sections of this document!

Maintenance

- Only original Doka components may be used as spare parts. Repairs may only be carried out by the manufacturer or authorised facilities.

Miscellaneous

The weights as stated are averages for new material; actual weights can differ, depending on material tolerances. Dirt accretions, moisture saturation, etc. can also affect weight.

We reserve the right to make alterations in the interests of technical progress.

Eurocodes at Doka

The permissible values stated in Doka documents (e.g. $F_{perm} = 70$ kN) are not design values (e.g. $F_{Rd} = 105$ kN), unless specified!

- It is essential to avoid confusing permissible values with design values!
- Doka documents will continue to state the permissible values.

Allowance has been made for the following partial factors:

- $\gamma_F = 1.5$
- $\gamma_{M, timber} = 1.3$
- $\gamma_{M, steel} = 1.1$
- $k_{mod} = 0.9$

Consequently, all the design values for an EC design calculation can be determined from the permissible values.

Symbols used

The following symbols are used in this document:



DANGER

This is a notifier drawing attention to an extremely dangerous situation in which non-compliance with this notifier will lead to death or severe, irreversible injury.



WARNING

This is a notifier drawing attention to a dangerous situation in which non-compliance with this notifier can lead to death or severe, irreversible injury.



CAUTION

This is a notifier drawing attention to a dangerous situation in which non-compliance with this notifier can lead to slight, reversible injury.



NOTICE

This is a notifier drawing attention to a situation in which non-compliance with this notifier can lead to malfunctions or damage to property.



Instruction

Indicates that actions have to be performed by the user.



Sight-check

Indicates that you need to do a sight-check to make sure that necessary actions have been carried out.



Tip

Points out useful practical tips.



Reference

Cross-references other documents.

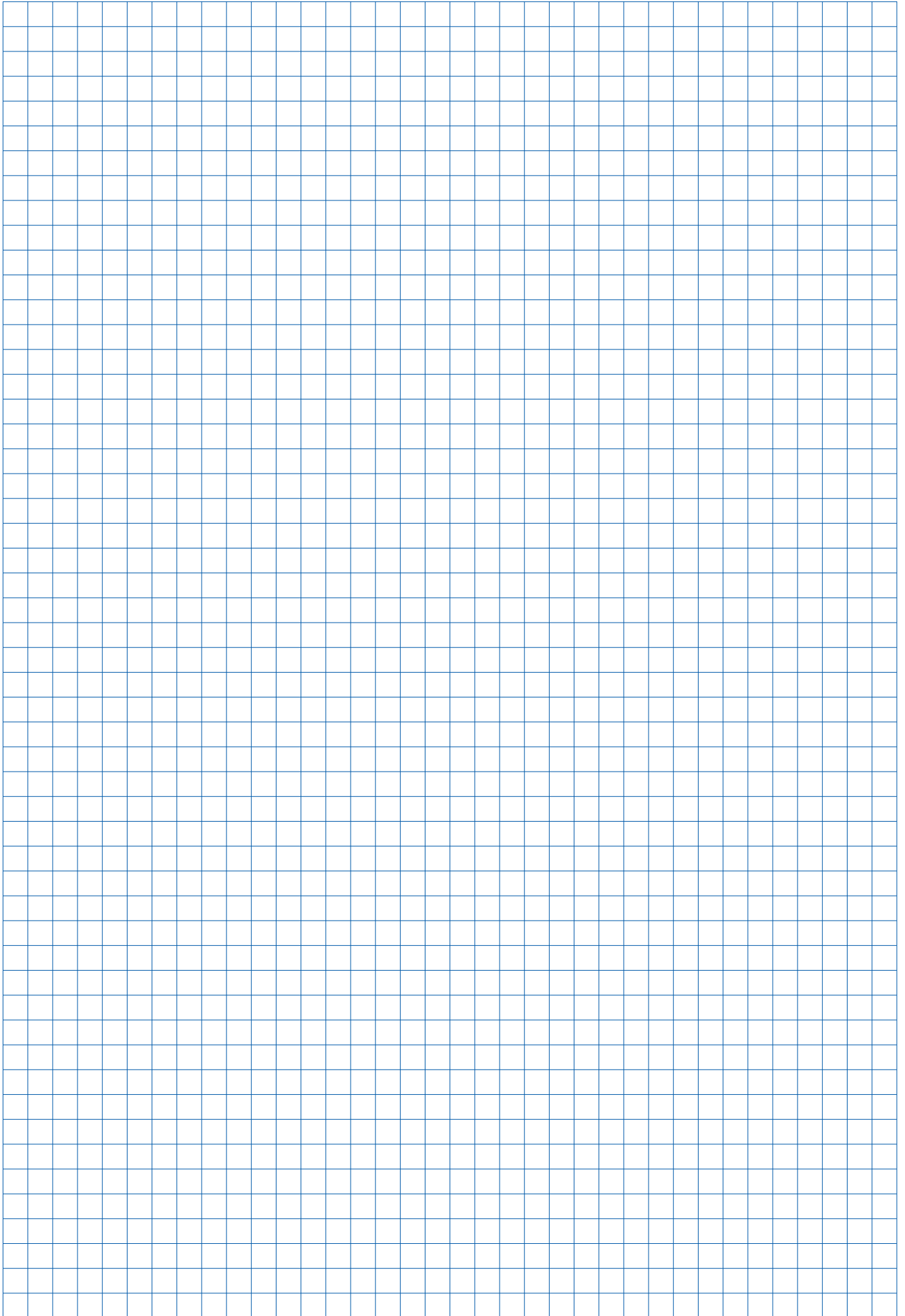

Intended use

The Framed formwork Framax Xlife plus is a formwork system for the cast-in-place concrete construction of walls, foundations and shafts.

The Framed formwork Framax Xlife plus is designed for setting up using a crane.

Boundary conditions for use:

- Max. formwork height: 8.10 m
- Max. wall thickness: 60 cm

In special cases, boundary conditions can vary. The relevant information in the Doka technical documents must be observed.

Other use or use not in conformity with that stated above is non-intended use and requires the prior written approval of the Doka company!

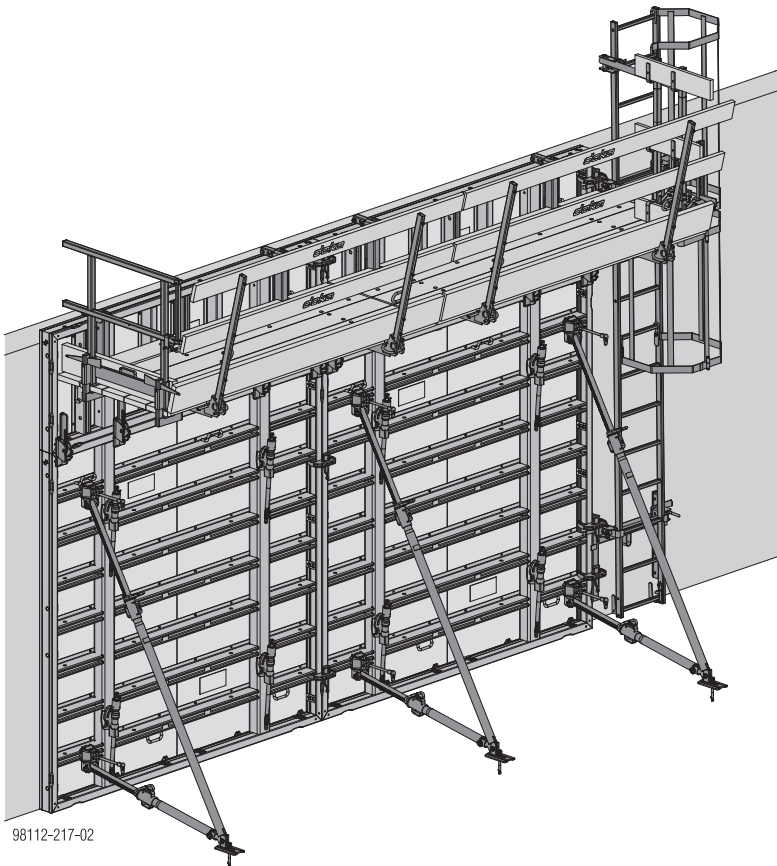

Wall formwork

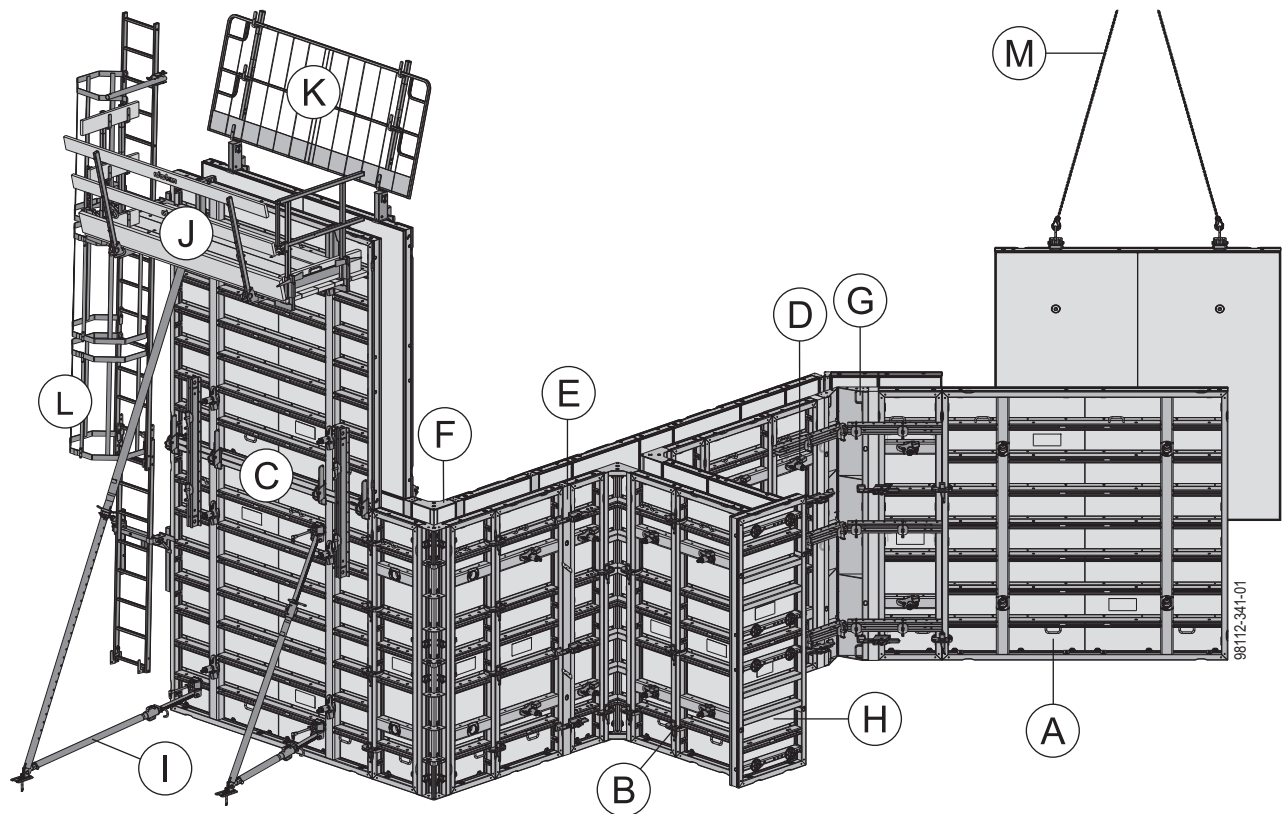

Section:

- A [Framax Xlife plus panel in detail](#)
- B [Inter-panel connections](#)
- C [Vertical stacking of panels](#)
- D [Tie rod system Framax Xlife plus](#)
- E [Length adjustment using closures](#)
- F [90 degree corners](#)
- G [Acute & obtuse-angled corners](#)
- H [Stop-end formwork](#)
- I [Plumbing accessories](#)
- J [Pouring platforms](#)
- K [Opposing guardrail](#)
- L [Ladder system](#)
- M [Lifting by crane](#)

Permitted fresh-concrete pressure:

See the sections headed [Framax Xlife plus panel in detail](#) and [Tie rod system Framax Xlife plus](#)

Instructions for assembly and use for room-high formwork

The sequence shown here is based on a straight wall. However, you should always start to form from the corner outwards.

Ladders must be located so as to create viable 'traffic routes' in the horizontal. (On a straight wall, for example, one ladder on the first element and another on the last).

If single brackets are used instead of pouring platforms, follow the instructions in the section headed [Pouring platforms with single brackets](#).

Transporting / handling the panels

- ▶ For offloading panels from a truck, or lifting them on-site (see the section headed [Transporting, stacking and storing](#)).
- ▶ To separate the panels, use Framax transport bolts and the Doka 4-part chain 3.20m (see the section headed [Transporting, stacking and storing](#)).

Pre-assembly

- ▶ Pre-assemble gang-forms face-down on a prepared flat area (see the section headed [Inter-panel connections](#)).
- ▶ With the gang-form still flat, mount panel struts to it (see the section headed [Plumbing accessories](#)).
- ▶ Install distance protectors with form tie in 'parked' position (see the section headed [Tying the panels](#)).
- ▶ Install Ladder system XS (including ladder cage, if necessary) (see the section headed [Ladder system](#)).

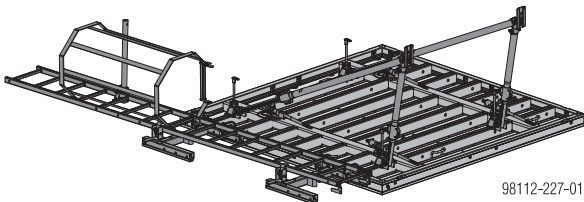

Closing the formwork

! NOTICE

- For working at heights that cannot be reached from the floor, use a suitable elevated platform (e.g. Platform stairway 0.97m, Wheel-around scaffold DF or mobile scaffold tower)!
- Always comply with the country-specific safety regulations!
- Do not step on to the pouring platform until an all-round guardrail system (including counter railing) is in place!
Otherwise wear a personal fall-arrest system (e.g. safety harness)!

- ▶ Attach the gang-form to the crane with Framax lifting hooks (see the section [Lifting by crane](#)).

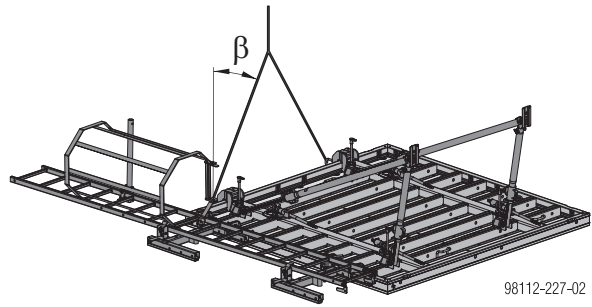

- ▶ Raise the gang-form by crane.
- ▶ Spray the formwork sheet with release agent (see the section headed [Cleaning and care of your equipment](#)).
- ▶ Fly the gang-form to its new location.



NOTICE

Never use a sledge hammer to plumb and align the panels!

This would damage the profiles of the gangs.

- ▶ Use only proper aligning tools (e.g. a special pry-bar) that cannot cause any damage (see the section [Tools for plumbing and aligning and for stripping the formwork](#)).
- ▶ Fix the panel struts firmly to the ground (see the section [Plumbing accessories](#)).

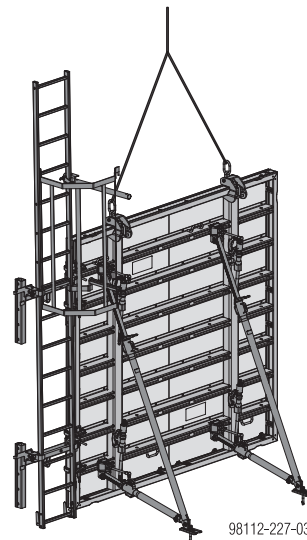

The gang-form is now stable and can be plumbed and aligned exactly, with no need for the crane.

- ▶ Use the Framax assembling tool to disengage the gang-form from the crane (see the section [Lifting by crane](#)).

- ▶ Engage the pouring platform with pre-installed end-of-platform sideguard (see the section [Pouring platforms](#)).

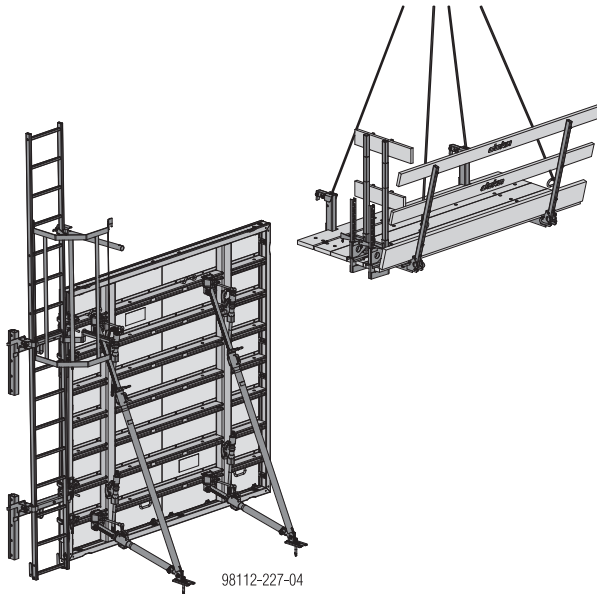

- ▶ Detach the pouring platform from the crane. The crew can reach the lifting points by standing on an elevated platform (for access, flip up the formwork-side deck-board).
- ▶ Continue lining up further gang-forms in this way, and link them together (see the section [Inter-panel connections](#)).

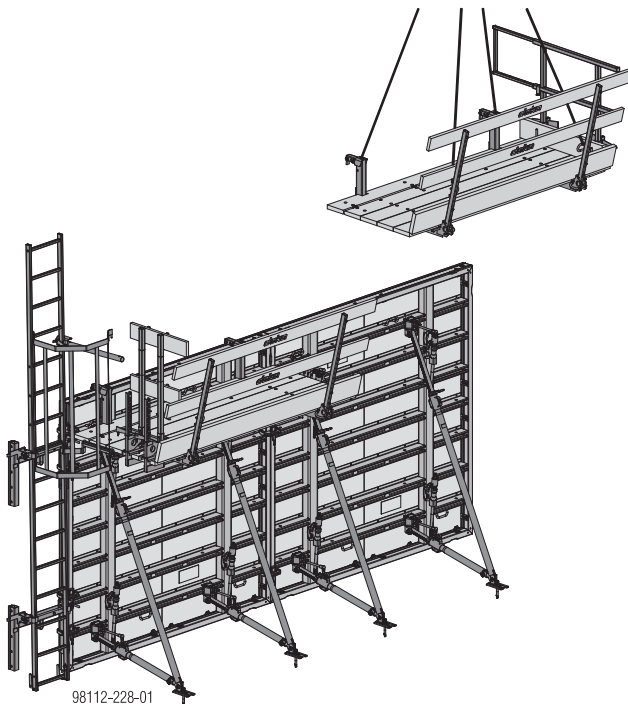

Erecting the opposing formwork:

Once the reinforcement has been placed, the formwork can be closed.

- ▶ With the gang-form of the opposing formwork laid flat, install form-tie nuts and counter railings (see the sections headed [Tying the panels](#) and [Opposing guardrail](#)).
- ▶ Spray the formwork sheet with release agent (see the section headed [Cleaning and care of your equipment](#)).
- ▶ Lift the opposing formwork by crane to its next location (see the section headed [Lifting by crane](#)).

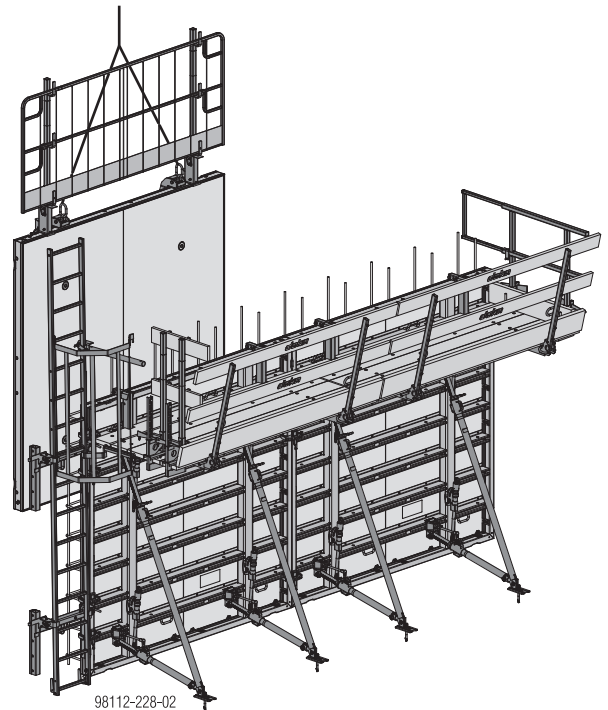

- ▶ Fit the form ties (see the section headed [Tie rod system Framax Xlife plus](#)).



WARNING

No panel struts on the opposing formwork!
Risk of the formwork tipping over!

- ▶ Do not disconnect the gang-form from the crane until a large enough number of form ties have been installed to keep it safely in the upright.

- ▶ Use the Framax assembling tool to disengage the crane tackle with Framax lifting hooks from the gang-form (see the section headed [Lifting by crane](#)).
- ▶ Continue lining up further gang-forms in this way, and link them together (see the section headed [Inter-panel connections](#)).

Pouring



NOTICE

Do not exceed the maximum permissible rate of placing.

Framed formwork Framax Xlife plus:

Permissible fresh-concrete pressure: See sections [Framax Xlife plus panel in detail](#) and [Tie rod system Framax Xlife plus](#).



Observe the section 'Pressure of fresh concrete on vertical formwork, DIN 18218' in the Calculation Guide 'Doka formwork engineering' or contact Doka.



Observe DIN 4235 Part 2 'Compacting of concrete by vibrating; Compacting by internal vibrators'.

- Lower the Xsafe plus counter railing.
- Pour the concrete.
- Make only moderate use of vibrators, carefully coordinating the times and locations of vibrator use.

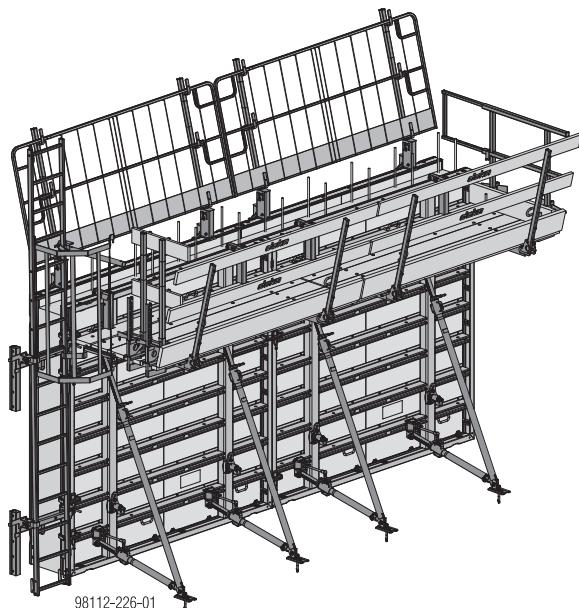

Stripping the formwork



NOTICE

- Comply with the stipulated stripping times.
- Remove any loose items from the formwork and platforms, or secure them firmly.
- Use the Framax assembling tool to position the crane tackle with Framax lifting hooks at the gang-form (see the section headed [Lifting by crane](#)).
- Take out the form ties (see the section headed [Tie rod system Framax Xlife plus](#)) and undo the connectors to the adjacent panels.

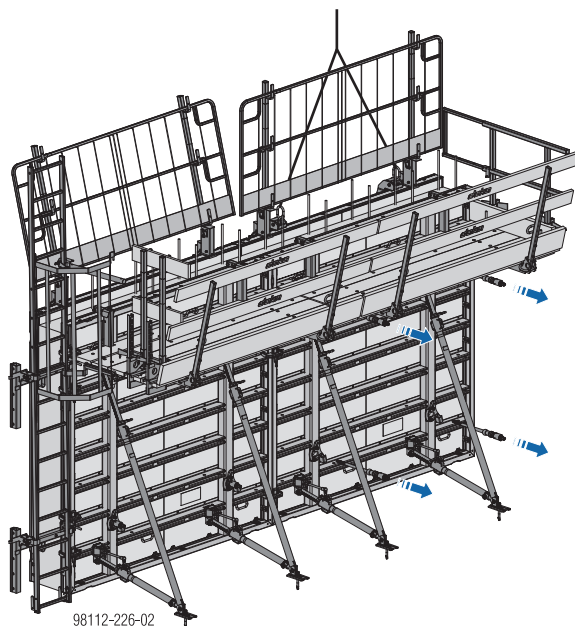

In order to speed up operations when lifting and repositioning by crane, most of the form ties can be taken out in advance.

Important!

There must be at least as many form ties left in place as are needed to keep the panels safely in the upright.



WARNING

The formwork tends to adhere to the concrete. When stripping the formwork, do not try to break concrete cohesion using the crane!

Risk of crane overload.

- Use suitable tools to detach the formwork from the concrete (see the section headed [Tools for plumbing and aligning and for stripping the formwork](#)).
- Lift the gang-form away and to its next location. If the gang-form is 'parked' prior to its next use, it must have sufficient stability (see the section headed [Plumbing accessories](#)). Gang-forms with only one panel strut must not be 'parked' upright, but placed face-down.
- Clean residual concrete off the formwork sheet (see the section headed [Cleaning and care of your equipment](#)).

- ▶ Where the gang-form has panel struts and a pouring platform attached to it, first attach this gang-form to the crane, and only then detach the floor anchorages of the panel struts.

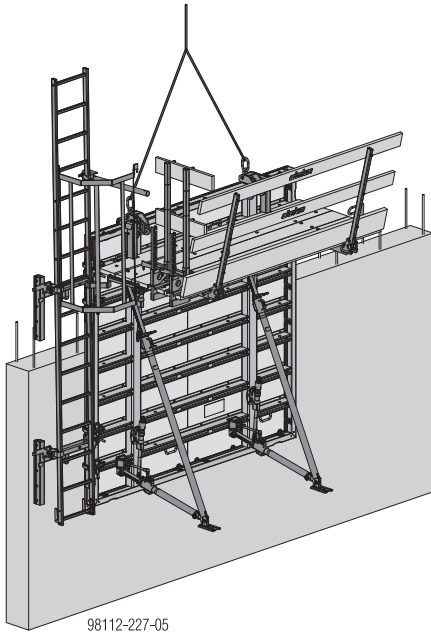

Instructions for assembly and use for high formwork

The sequence shown here is based on a straight wall. However, you should always start to form from the corner outwards.

Ladders must be located so as to create viable 'traffic routes' in the horizontal. (On a straight wall, for example, one ladder on the first element and another on the last).



Follow the directions in the 'Xsafe platform system plus' User Information booklet.

If single brackets are used instead of pouring platforms, follow the instructions in the section headed [Pouring platforms with single brackets](#).

Transporting / handling the panels

- ▶ For offloading panels from a truck, or lifting them on-site (see the section headed [Transporting, stacking and storing](#)).
- ▶ To separate the panels, use Framax transport bolts and the Doka 4-part chain 3.20m (see the section headed [Transporting, stacking and storing](#)).

Pre-assembly

- ▶ Pre-assemble gang-forms face-down on a prepared flat area (see section [Inter-panel connections](#)).
- ▶ Attach the Tie-off set PPE type A*) for the personal fall-arrest system to the frame profile or function profile.

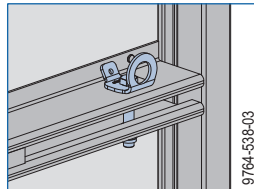
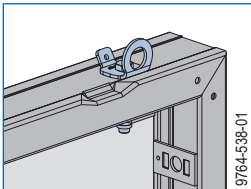

*) tested according to EN 795 (type A)

- ▶ Install distance protectors with form tie in 'parked' position (see section [Tying the panels](#)).
- ▶ Install the platforms, access system (incl. ladder cage, as necessary) and panel struts on the gang-form while it is laid flat (see sections [Pouring platforms](#) and [Plumbing accessories](#)).

The Xsafe plus counter railing must be in the pushed-in position.

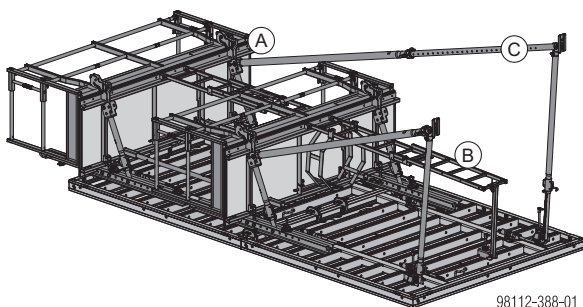

B Access system

C Panel strut

Closing the formwork



NOTICE

- For working at heights that cannot be reached from the floor, use a suitable elevated platform (e.g. Platform stairway 0.97m, Wheel-around scaffold DF, mobile scaffold tower or scissor-type elevated work platform)!
- Always comply with the country-specific safety regulations!
- Do not step on to the pouring platform until an all-round guardrail system (including counter railing) is in place!
Otherwise wear a personal fall-arrest system (e.g. safety harness)!

- ▶ Install Xsafe plus lifting walers on the gang-form.
- ▶ Attach the crane to the Xsafe plus lifting walers (see the section headed [Lifting by crane](#)).
- ▶ Raise the gang-form by crane.
- ▶ Spray the formwork sheet with release agent (see the section headed [Cleaning and care of your equipment](#)).
- ▶ Lift the gang-form to its new location.



NOTICE

Never use a sledge hammer to plumb and align the panels!

This would damage the profiles of the gangs.

- ▶ Use only proper aligning tools (e.g. a special pry-bar) that cannot cause any damage (see the section headed [Tools for plumbing and aligning and for stripping the formwork](#)).
 - ▶ Fix the panel struts firmly to the ground (see the section headed [Plumbing accessories](#)).
- The gang-form is now stable and can be plumbed and aligned exactly, with no need for the crane.

A Platform

**WARNING**

No all-round guardrail system present on the pouring platform!

Danger to life from fatal falls!

- ▶ Use a personal fall-arrest system (e.g. safety harness)
The Tie-off set PPE type A (A) connected to the framed formwork panel serves as attachment point.

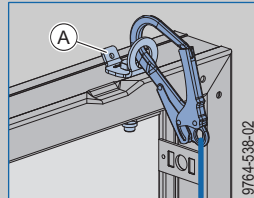

- ▶ Extend the Xsafe plus counter railing.

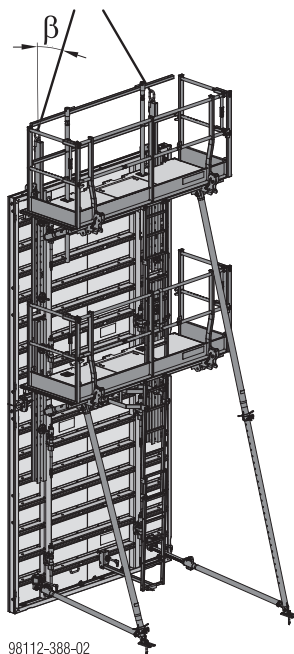

- ▶ Detach the gang-form from the crane.
- ▶ Continue lining up further gang-forms in this way, and link them together (see the section headed [Inter-panel connections](#)).

Erecting the opposing formwork:

Once the reinforcement has been placed, the formwork can be closed.

- ▶ With the gang-form of the opposing formwork laid flat, install form-tie nuts, counter railings and intermediate platforms (see the sections headed [Tying the panels](#), [Opposing guardrail](#) and [Pouring platforms](#)).
- ▶ Spray the formwork sheet with release agent (see the section headed [Cleaning and care of your equipment](#)).
- ▶ Lift the opposing formwork by crane to its next location (see the section headed [Lifting by crane](#)).

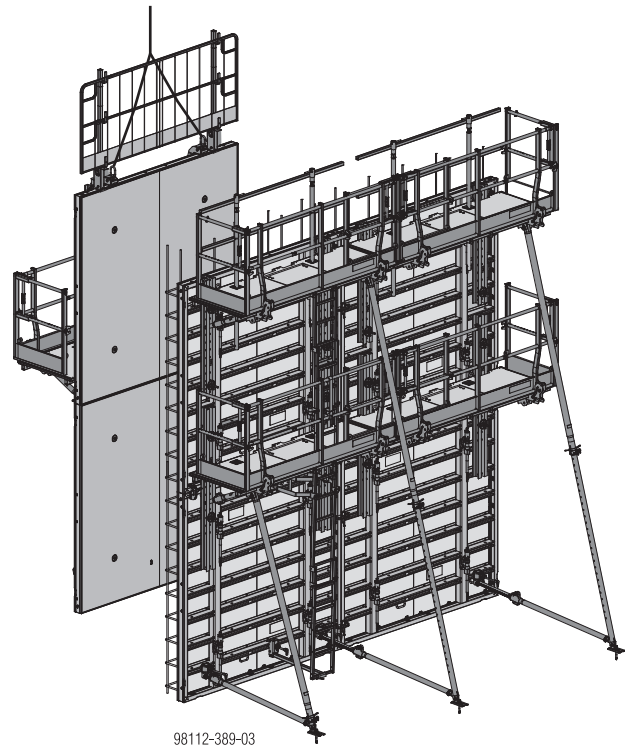

- ▶ Working from the ground, insert the bottom two rows of form ties (see the section headed [Tie rod system Framax Xlife plus](#)).



Before disconnecting from the crane:

- ▶ If there are no panel struts on the opposing formwork, do not disconnect the panel from the crane until a large enough number of form ties have been installed to keep it safely in the upright.

- ▶ Detach the gang-form from the crane.
- ▶ Insert the remaining form ties (see the section headed [Tie rod system Framax Xlife plus](#)). These form-tie points can be reached from the platforms.
- ▶ Continue lining up further gang-forms in this way, and link them together (see the section headed [Inter-panel connections](#)).

Pouring



NOTICE

Do not exceed the maximum permissible rate of placing.

Framed formwork Framax Xlife plus:

Permissible fresh-concrete pressure: See sections [Framax Xlife plus panel in detail](#) and [Tie rod system Framax Xlife plus](#).



Observe the section 'Pressure of fresh concrete on vertical formwork, DIN 18218' in the Calculation Guide 'Doka formwork engineering' or contact Doka.



Observe DIN 4235 Part 2 'Compacting of concrete by vibrating; Compacting by internal vibrators'.

- Lower the Xsafe plus counter railing.
- Pour the concrete.
- Make only moderate use of vibrators, carefully coordinating the times and locations of vibrator use.

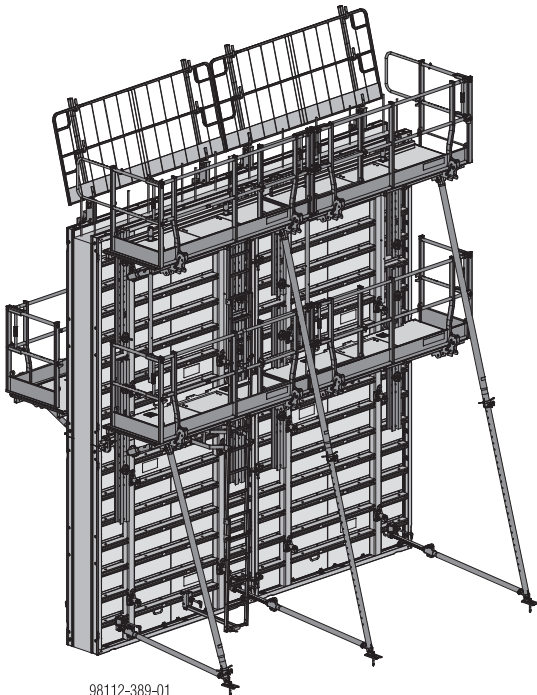

Stripping the formwork



NOTICE

- Comply with the stipulated stripping times.
 - Remove any loose items from the formwork and platforms, or secure them firmly.
- Begin work on stripping the formwork on the opposing formwork:**



WARNING

- There must be at least as many form ties left in place as are needed to keep the panel safely in the upright.
- Take out the form ties from the two top rows of ties (see the section headed [Tie rod system Framax Xlife plus](#)). These form-tie points can be reached from the platforms.
- Attach the gang-form of the opposing formwork to the crane.
- Working from the floor, remove the bottom two rows of form ties (see the section headed [Tie rod system Framax Xlife plus](#)) and undo the connectors to the adjacent panels.

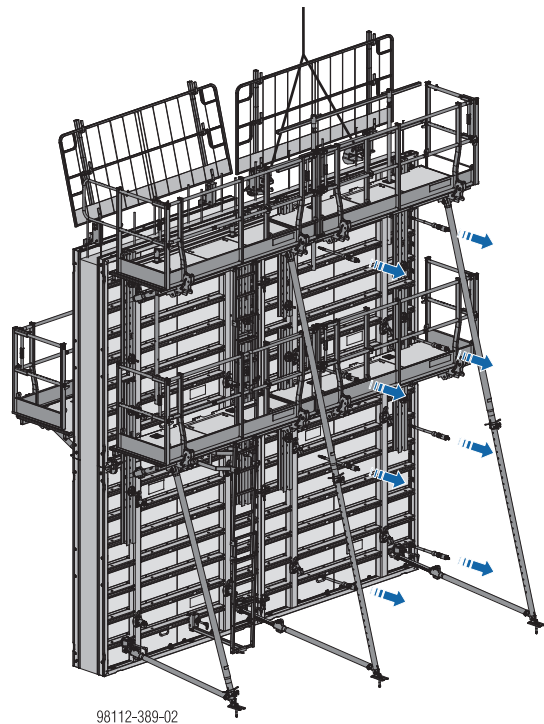

WARNING

- The formwork tends to adhere to the concrete. When stripping the formwork, do not try to break concrete cohesion using the crane! Risk of crane overload.
- Use suitable tools to detach the formwork from the concrete (see the section headed [Tools for plumbing and aligning and for stripping the formwork](#)).
- Lift the gang-form away and to its next location, or place it flat on its back for intermediate storage.
- Clean residual concrete off the formwork sheet (see the section headed [Cleaning and care of your equipment](#)).

- ▶ Where the gang-form has panel struts attached to it, first attach this gang-form to the crane, and only then detach the floor anchorages of the panel struts.

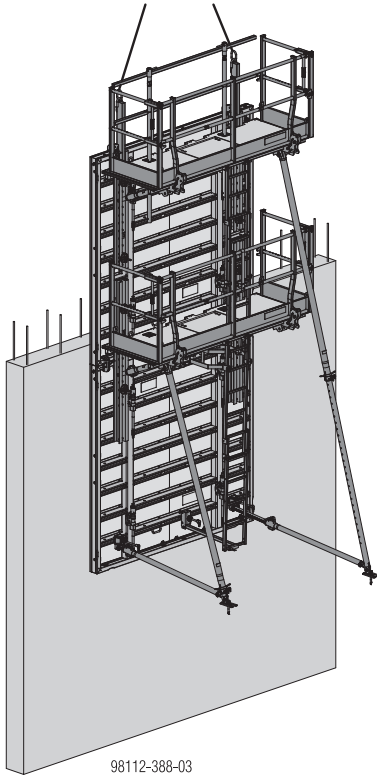

Framax Xlife plus panel in detail

High load-bearing capacity

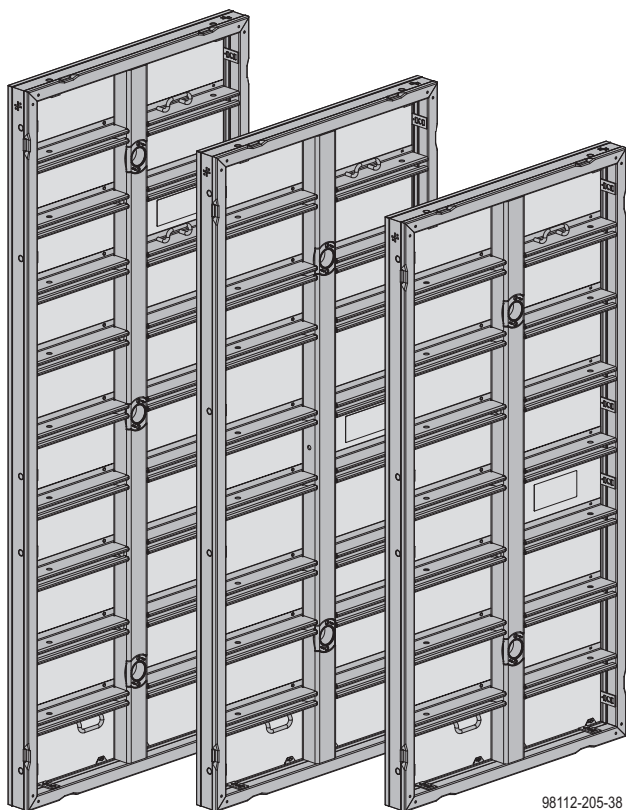

80 kN/m² pressure of fresh concrete acting on whole area, to DIN 18218, where the surface planeness tolerances to DIN 18202 Table 3 Line 6 are observed.

Exception: 75kN/m² in the case of 3.00m high panels!

Clean concrete surfaces with the innovative Xlife sheet

The Xlife sheet ensures high numbers of repeat use, it is less prone to damage and gives a superb concrete finish every time.

- High quality concrete finish
- Less touching-up needed
- Less cleaning - the Xlife sheet can be cleaned using a high-pressure spray cleaner
- The sheeting is screwed on from the back, preventing rivet impressions in the concrete and making cleaning easier

Dimensionally stable, galvanised and powder-coated steel frame

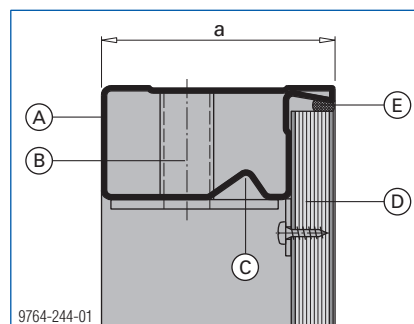

a ... 123 mm

- A** Frame profile
- B** Cross borehole
- C** Continuous hardware slot for inter-panel connectors
- D** Xlife sheet
- E** Silicone sealing strip

- Dimensionally stable frame profiles
- Powder-coated, so easy to clean
- Edges are easy to clean - panels always butt tightly
- All-round hardware slot for fastening the inter-panel connectors at any point
- Hot-dip galvanised for long life
- Formwork sheet is edge-protected by the frame profile
- Cross boreholes for corner configurations and stop-ends



WARNING

► It is forbidden to climb on the function profiles. The function profiles are NOT a substitute for a ladder.

Accessories are easy to fasten in the function profile

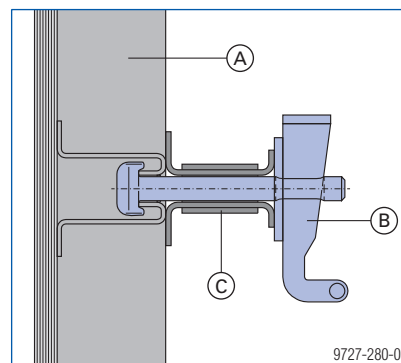

- A** Framax Xlife plus panel
- B** Framax wedge clamp
- C** Framax universal waling

Form-tie sleeves

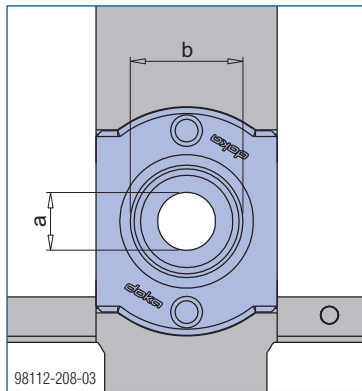

a ... diam. 32 mm

b ... diam. 80 mm

- Large, centrally arranged anchoring sleeves with steel sealing edge
- Only 2 form ties per 2.70 m and 3.00 m of panel height

Handles

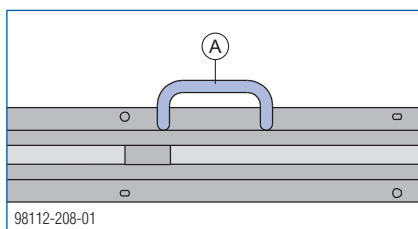

A Integral handle



WARNING

Do not use these integrated handles as slinging points for crane-handling!

Danger of formwork dropping from crane!

- ▶ Use only suitable lifting accessories and slinging points. See the sections headed [Lifting by crane](#) and [Transporting, stacking and storing](#).

Lifting edge

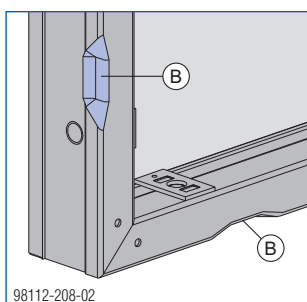

B Lifting edge

- Practical lifting edge, as an insertion point for the aligning tool

Panel versions

Manufactured from 2022 onwards

- all cross profiles are designed as function profiles
- holes for DokaXact
- powder-coated grey

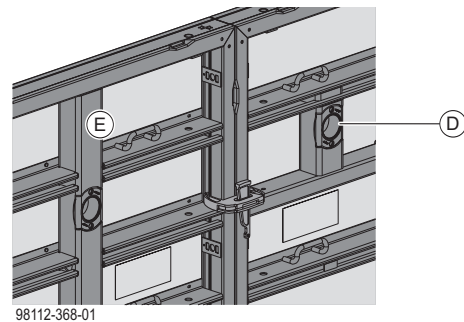

D Framax Xlife plus panel 0.90x3.30m (art. n° 589292600)

E Framax Xlife plus panel 1.35x3.30m (art. n° 589291600)

Manufactured between 2019 and 2021: Height 3.30 m, Manufactured between 2015 and 2021: Height 2.70 and 1.35 m (code letter C)

- changed position of the function profiles (compatible with the version manufactured from 2022 onwards)
- with transparent powder coating (except extra-large panels)

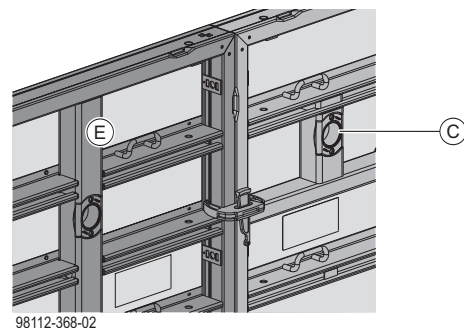

C Framax Xlife plus panel C 0.90x3.30m (art. n° 589292500)

E Framax Xlife plus panel 1.35x3.30m (art. n° 589291600)

Manufactured between 2015 and 2018 (code letter B)

- a further development of the first generation (code letter A)
- position of the top and bottom function profiles not compatible with versions manufactured from 2019 onwards
- with transparent powder coating (except extra-large panels)

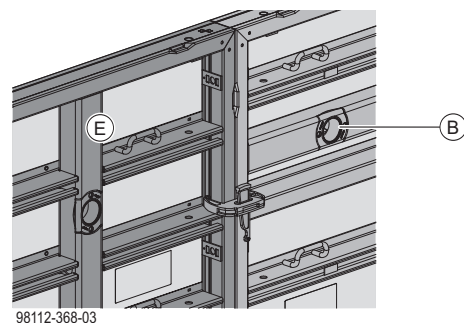

B Framax Xlife plus panel B 0.90x3.30m (art. n° 589292000)

E Framax Xlife plus panel 1.35x3.30m (art. n° 589291600)

System grid



98112-205-01

For details, see [Article list](#)

Framax Xlife plus panels

The heights and widths of the Framax Xlife plus panels together result in a logical, advantageous increment-grid that makes this formwork highly flexible and economical.

- Easy planning and forming
- 15 cm grid
- Very few closures needed
- Clear joint pattern
- Symmetrically arranged, centred form ties

Panel widths

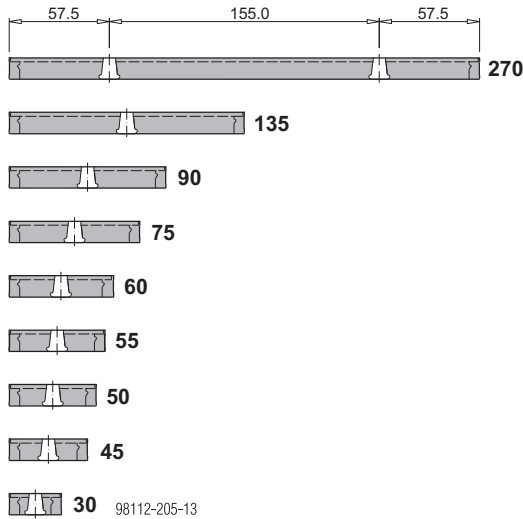

Dimensions in cm

Note:

Additional panel widths are available on request.

Panel heights

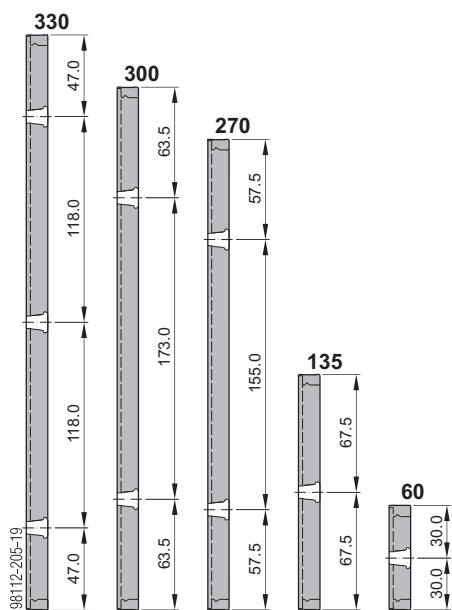

Dimensions in cm

Universal panels

The special hole pattern makes these panels particularly suitable for efficient forming of:

- corners
- wall junctions
- stop-ends
- columns

Framax Xlife universal panels

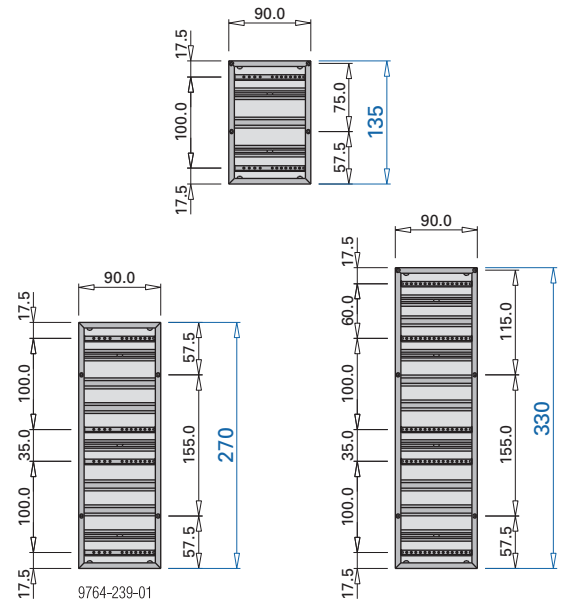

Dimensions in cm

Framax Xlife plus universal panel 0.90x3.00m

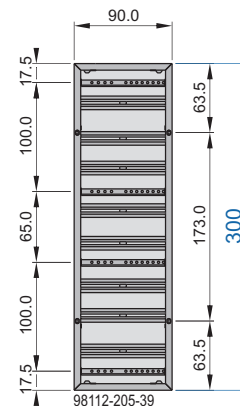

Dimensions in cm

Inter-panel connections

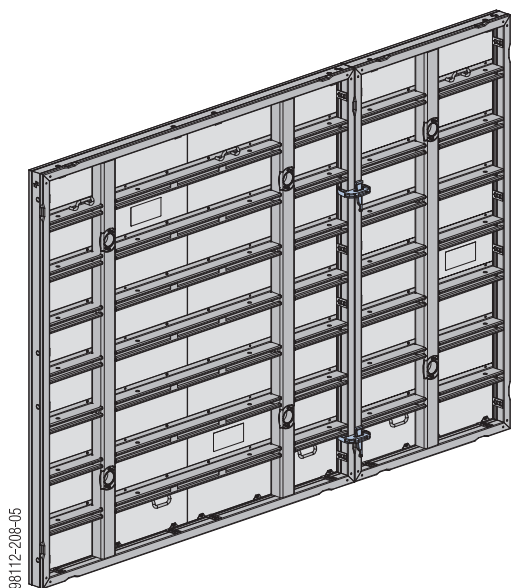

Inter-panel connections are easy with Framax quick acting clamps RU

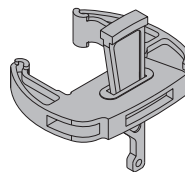

Framax quick acting clamp RU:

permitted tensile force: 15.0 kN

permitted shear force: 6.0 kN

permitted moment: 0.5 kNm

The continuous hardware slot running around the inside of the frame profile means that panels can be fastened together at any point desired. This allows adjacent panels to be staggered in height, steplessly.

Attributes of the panel connectors:

- provide self-aligning, crane-handleable connections between the panels
- have no loose parts which might get lost
- dirt-resistant and hard-wearing for site use
- easy to fix, with a formwork hammer



NOTICE

- Use a formwork hammer weighing max. 800 g.
- Do not oil or grease wedged connections.

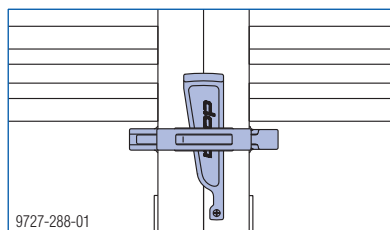
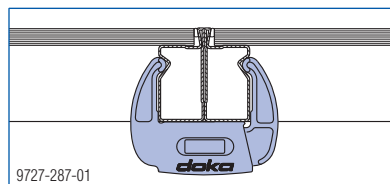

Number of inter-panel connections

Vertical inter-panel joint:

Panel height (panel upright)	Number of clamps
0.60m	1
1.35m	2
2.70m	2
3.00m	3
3.30m	3

Panel width (panel on its side)	Number of clamps
0.30 - 0.55m	1
0.60 - 1.35m	2

Horizontal inter-panel joint:

See the section headed [Vertical stacking of panels](#) for details on the positions of the Framax quick acting clamps RU, Framax multi function clamps and Framax aligning clamps needed for **vertical stacking**.

Note:

For details regarding extra inter-panel connections on outside corners and stop-ends (for increased tensile loads) see the section headed [Inter-panel connections for increased tensile loads](#).

Filler inter-panel connection with Framax multi function clamp

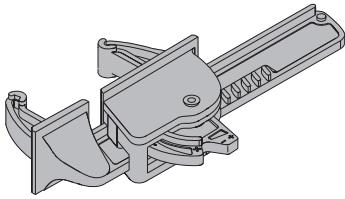

Framax multi function clamp:

- Permitted tensile force: 15.0 kN
- Permitted shear force: 9.0 kN
- Permitted moment: 0.9 kNm
- Values apply only when mounted on profile.

Particularly when panels are stacked in the vertical, the fact that the clamp bears directly on the profiles means that there is often no need for any extra bracing of the panels with universal walings.

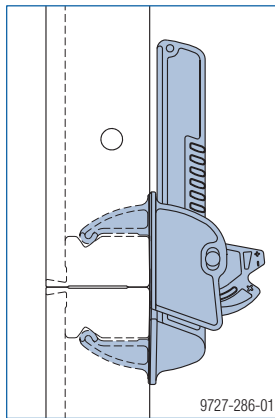
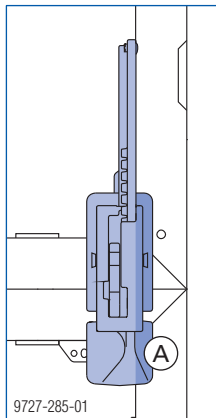

A Contact surface on the profile

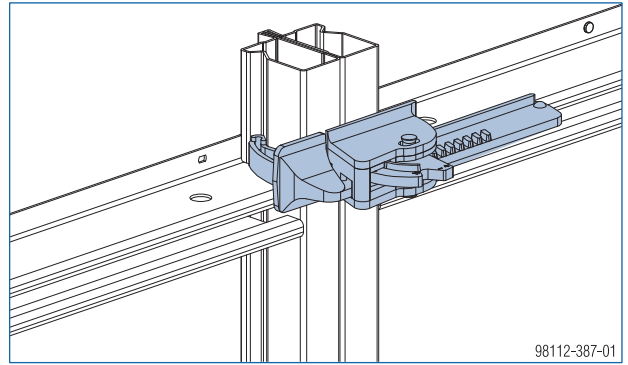

Joining the panels using the Framax multi function clamp provides additional bracing of the gang-form (as the clamp bears directly onto the profile).

Filler connection up to 15 cm

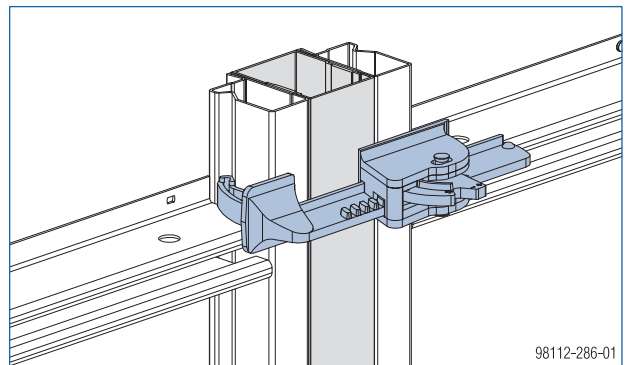

With its 15 cm clamping range, the Framax multi function clamp exactly matches the panel size-grid. For more information, see the section headed [Length adjustment using closures](#).

Squared timber connection up to 20 cm

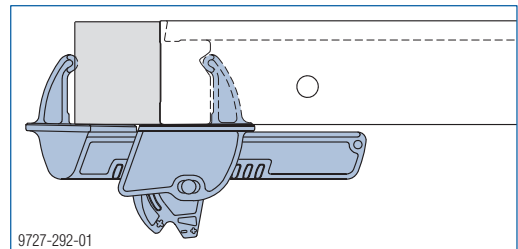

Bracing inter-panel connection with Framax aligning clamp

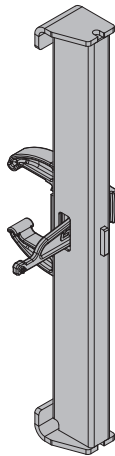

Framax aligning clamp:

Permitted tensile force: 15.0 kN

Permitted shear force: 6.0 kN

Permitted moment: 1.5 kNm

Values apply only when mounted on profile.

Particularly when panels are stacked in the vertical, the fact that the clamp bears directly on the profiles means that there is often no need for any extra bracing of the panels with universal walings.

The installation procedure is similar to that for the Framax quick acting clamp RU.

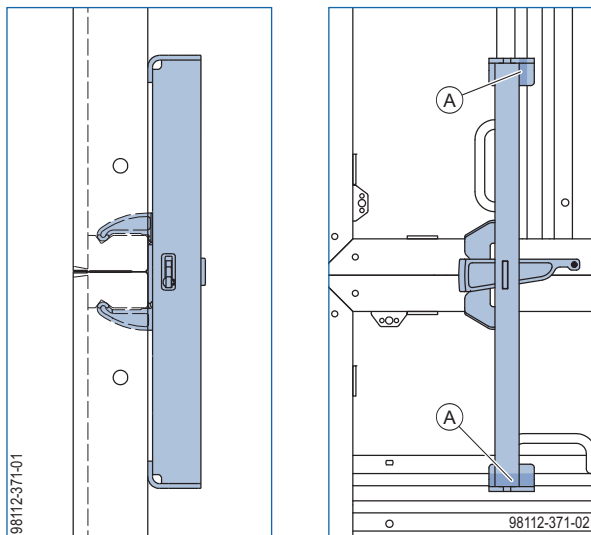

A Contact surface on the profile

Panel bracing with Framax universal waling

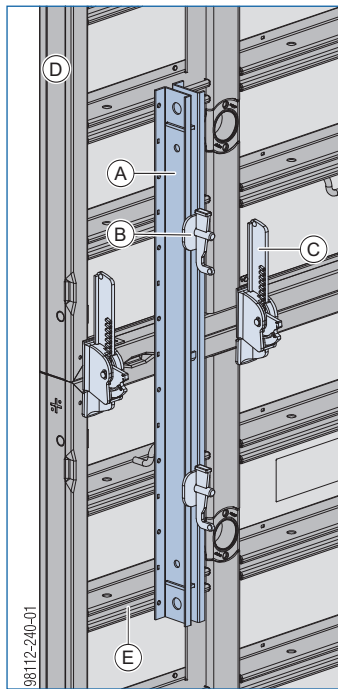

- A Framax universal waling 1.50m
- B Framax wedge clamp
- C Framax multi function clamp
- D Framax Xlife plus panel
- E Function profile as bearing surface for universal waling

Using additional universal walings gives gang-forms better rigidity, especially in higher **vertically stacked configurations**. This makes it possible to pick up and set down large gang-forms by crane without any problems. The additional universal walings are also useful for transferring the loads from platforms.

Note:

Instead of the universal waling, it is also possible to use a Multi-purpose waling WS10 Top50.

Framax universal waling:

Permitted moment (for vertical stacking of panels):
5.0 kNm

Due to the permitted tensile load of 14 kN in the function profile, even stiffer components such as Multi-purpose walings WS10 Top50 are also subject to: permitted moment 5.0 kNm

How to attach

using the Framax wedge clamp or universal clamp

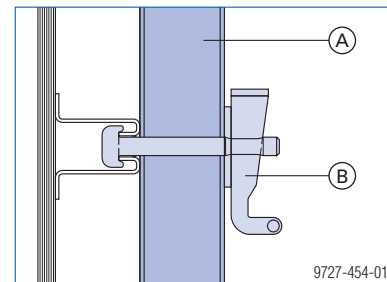

- A Framax universal waling
- B Framax wedge clamp or Universal clamp 5-10cm



NOTICE

Do not oil or grease wedged connections.

using the Framax universal fixing bolt and Super plate

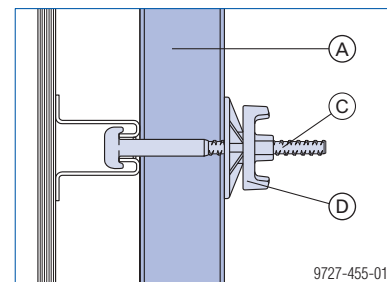

- A Framax universal waling
- C Framax universal fixing bolt
- D Super plate 15.0

Bracing of single form-tie panels



NOTICE

If more than two single form-tie panels are used next to each other, bracing with universal walings will be required.

Single form-tie panels:

Panel width 0.30 to 1.35m

Note:

- Position the universal walings in such a way that **at most two single form-tie panels without bracing are placed side by side**.
- Universal walings are required only **in the bottom function profile**.
- Max. closure width** between the single form-tie panels: **15 cm** using the **Framax multi function clamp**

Example with 5 single form-tie panels

CORRECT position of the universal waling:

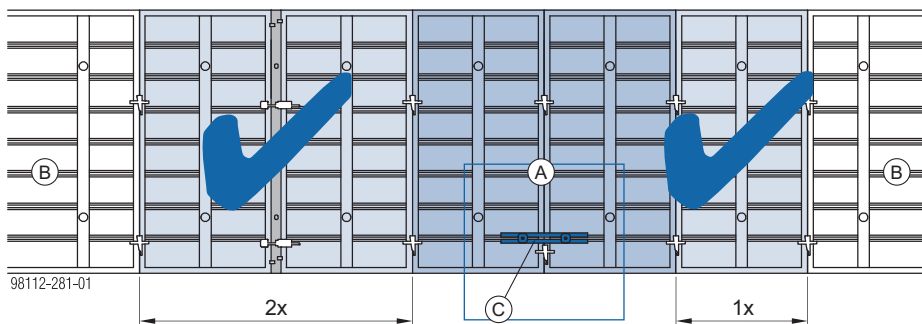

Alternative with Framax aligning clamp:

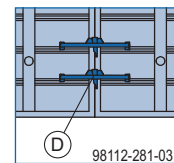

WRONG position of the universal waling:

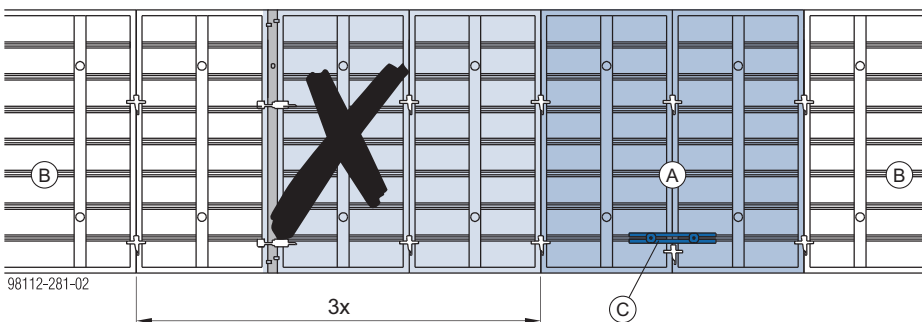

x ... single form-tie panel without bracing

- A Framax Xlife plus panels braced with a universal waling
- B Framax Xlife plus panel 2.70x2.70m
- C Framax universal waling + Framax wedge clamps
- D Framax aligning clamp

Corner configuration with single form-tie panels (example)

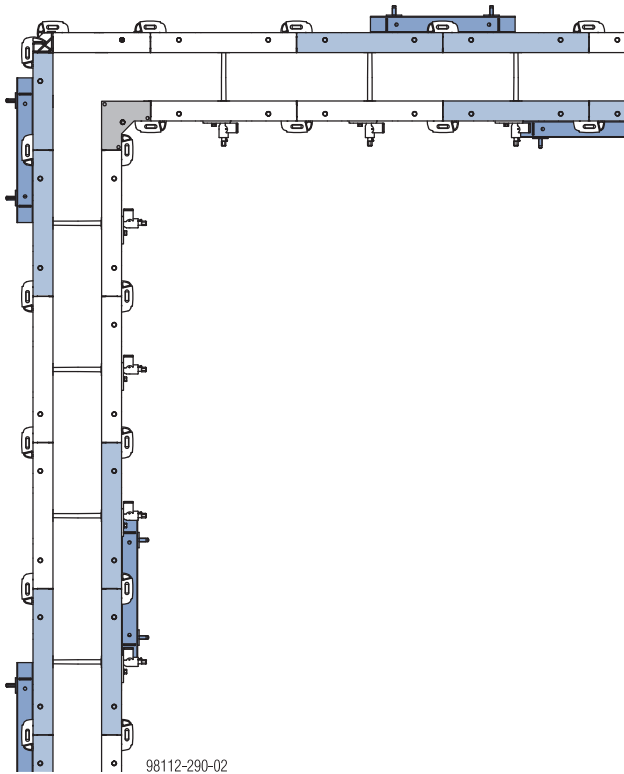

Example with 3 single form-tie panels turned on their sides

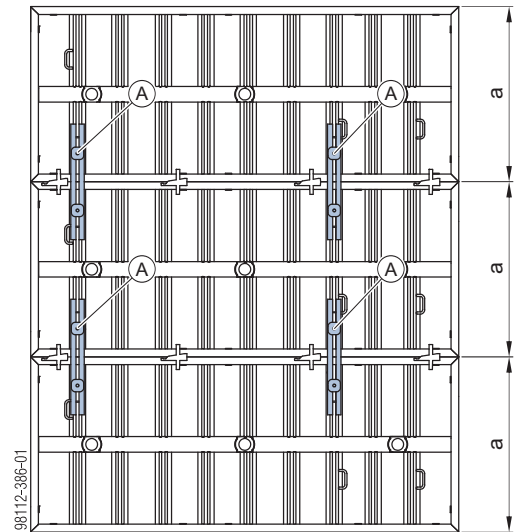

a ... panels up to 1.35m wide

A Framax universal waling 0.90m + Framax wedge clamps

Example with 4 single form-tie panels turned on their sides

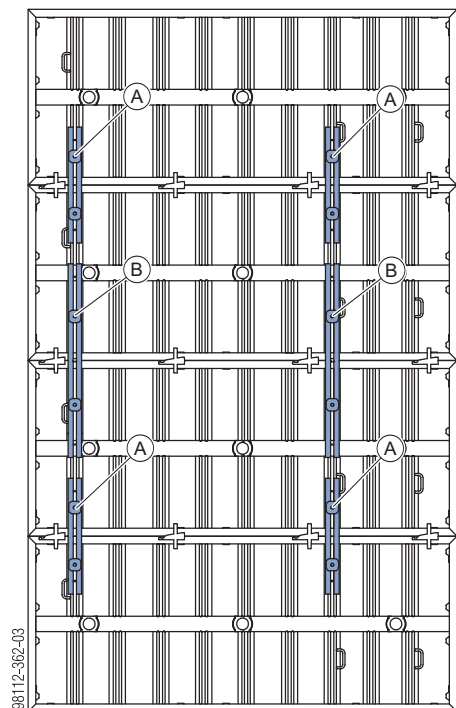

a ... panels up to 1.35m wide

A Framax universal waling 0.90m + Framax wedge clamps

B Framax universal waling 1.50m + Framax wedge clamps

Bracing of single form-tie panels on their side



NOTICE

Vertically stacked **single form-tie panels turned on their sides** require bracing with universal walings.

The positions of the universal walings shown here are for gang-form widths 2.70m to 3.30m!

Example with 2 single form-tie panels turned on their sides

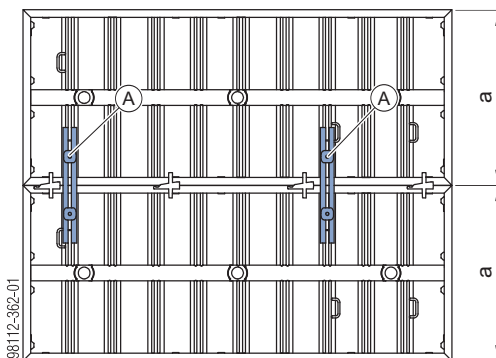

a ... panels up to 1.35m wide

A Framax universal waling 0.90m + Framax wedge clamps

Vertical stacking of panels

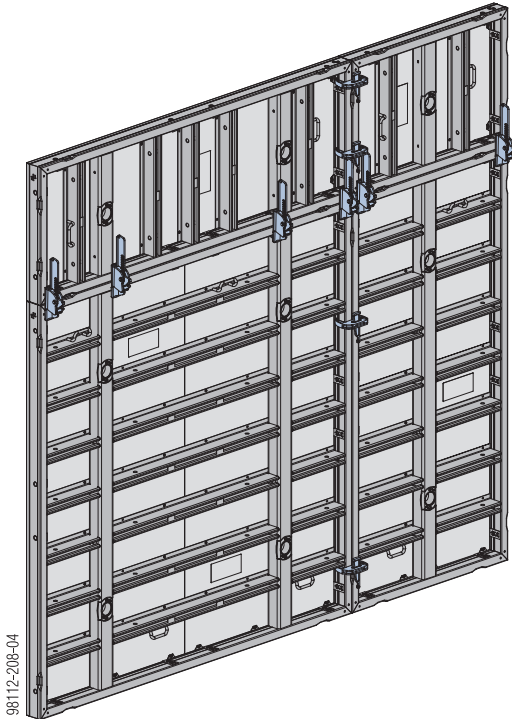

Positions of the necessary connectors, form-tie components and accessories for:

- Lifting and setting down
- Crane-handling
- Pouring platform
- Concrete pouring

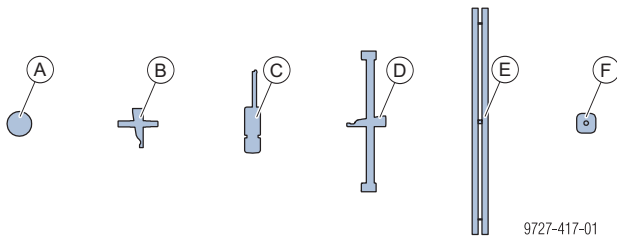

- A** Framax Xlife plus form tie 20.0
[Tie rod system Framax Xlife plus](#)
- B** Framax quick acting clamp RU
[Inter-panel connections are easy with Framax quick acting clamps RU](#)
- C** Framax multi function clamp
[Filler inter-panel connection with Framax multi function clamp](#)
- D** Framax aligning clamp
[Bracing inter-panel connection with Framax aligning clamp](#)
- E** Framax universal waling
[Panel bracing with Framax universal waling](#)
- F** Framax wedge clamp
[Panel bracing with Framax universal waling](#)

Framax quick acting clamp RU:

Permissible tensile force: 15.0 kN
Permissible shear force: 6.0 kN
Permissible moment: 0.5 kNm

Framax multi function clamp:

Permissible tensile force: 15.0 kN
Permissible shear force: 9.0 kN
Permissible moment: 0.9 kNm
Values apply only when mounted on profile.

Framax aligning clamp:

Permissible tensile force: 15.0 kN
Permissible shear force: 6.0 kN
Permissible moment: 1.5 kNm
Values apply only when mounted on profile.

Framax universal waling:

Permissible moment (for vertical stacking): 5.0 kNm
Due to the permissible tensile load of 14 kN in the function profile, even stiffer components such as Multi-purpose walings WS10 Top50 are also subject to: permissible moment 5.0 kNm



The **planning software Tipos-Doka** is always very helpful when it comes to finding the optimum technical and economical solution for the formwork issue concerned.

Framax Xlife plus panel 2.70m

with Framax multi function clamp

Number of Framax multi function clamps needed at each vertically stacked panel joint

Width of upright panels	Framax multi function clamp
0.30 - 0.55 m	1
0.60 - 1.35 m	2
2.70 m	4 (+1 *)

*) formwork height 405 cm or 2nd inter-panel joint without universal waling.

Number of universal walings needed at each vertically stacked panel joint

Formwork height	1st panel joint	2nd panel joint	3rd panel joint
300 - 495 cm	1 ¹⁾	—	—
540 - 675 cm	2	1	—
705 - 810 cm	2 (+1 ²⁾)	2 (+1 ²⁾)	1

The values given in the table apply for a gang-form width of 270 cm.

¹⁾ up to 405 cm not needed when a lightweight pouring platform with single brackets is used.

²⁾ only needed if intermediate platforms are to be used.

Formwork height: 300 and 315 cm

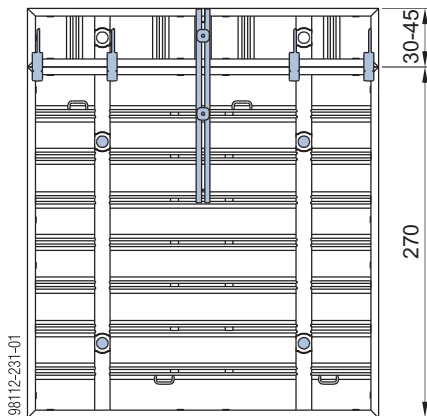

When using a lightweight pouring platform with single brackets (Framax bracket 90), the universal waling is not necessary.

Formwork height: 320, 325, 330, 345 and 360 cm

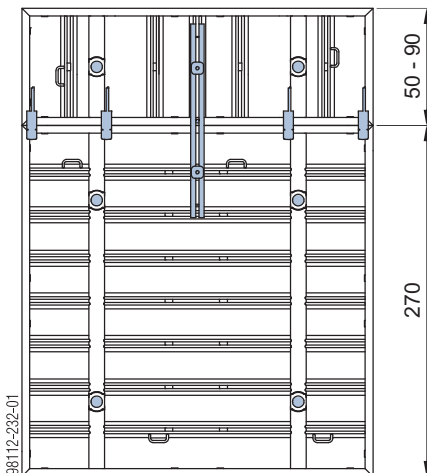

When using a lightweight pouring platform with single brackets (Framax bracket 90), the universal waling is not necessary.

Formwork height: 405 cm

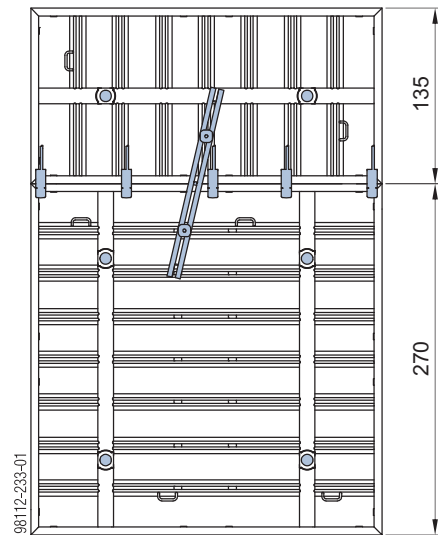

When using a lightweight pouring platform with single brackets (Framax bracket 90), the universal waling is not necessary.

Formwork height: 435 and 450 cm

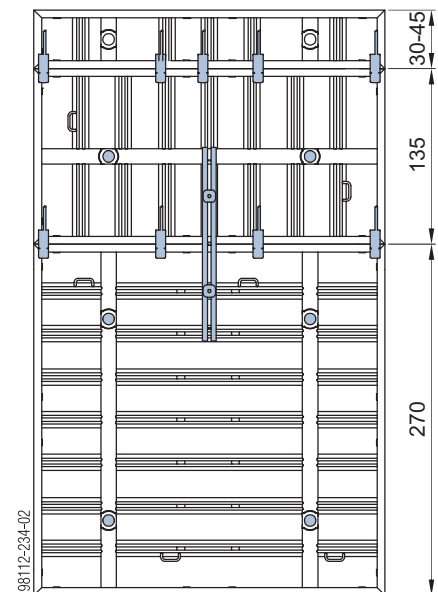

Formwork height: 455, 460, 465, 480 and 495 cm

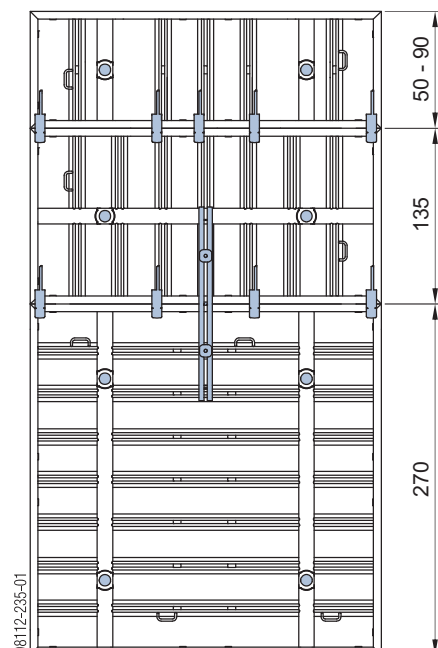

Formwork height: 540 cm

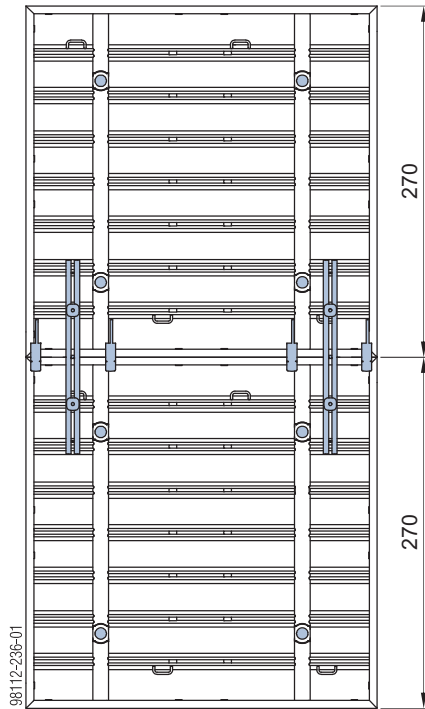

Formwork height: 590, 595, 600, 615, 630 and 675 cm

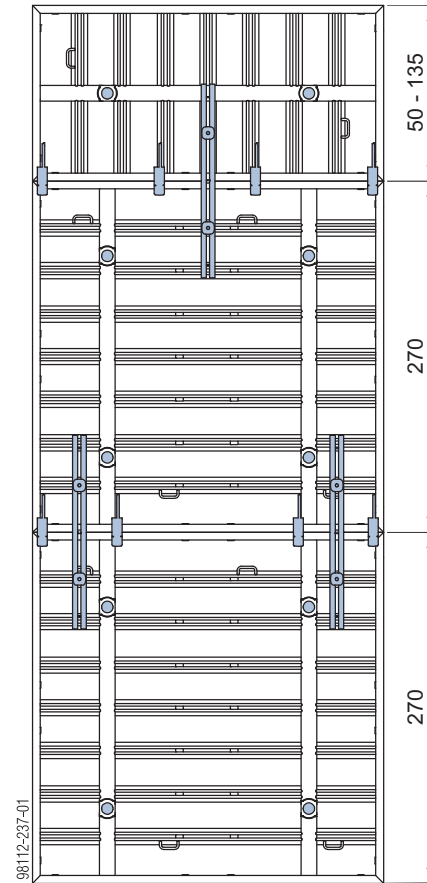

Formwork height: 570 and 585 cm

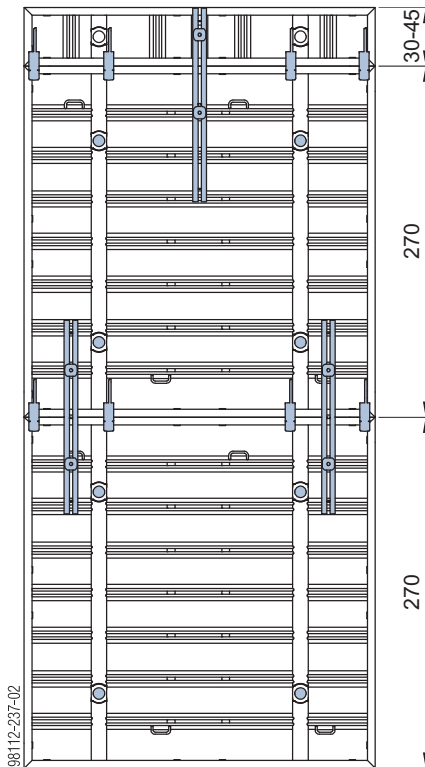

Formwork height: 705 and 720 cm

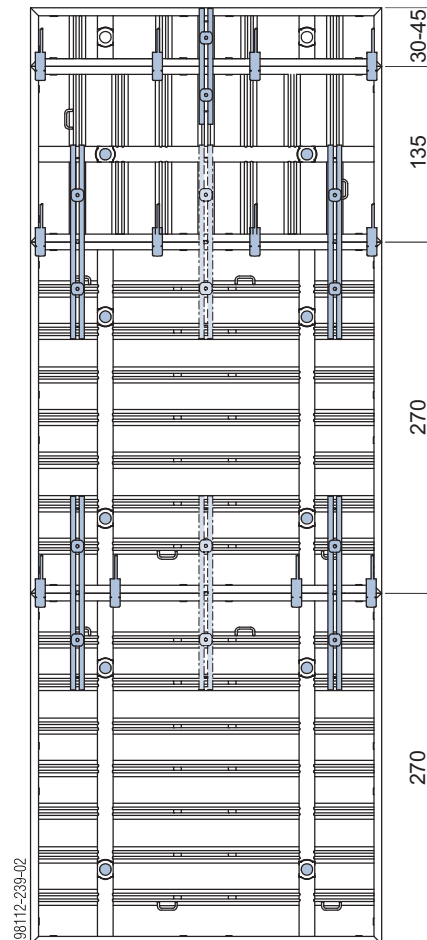

The third universal waling at the first and the second panel joint is only needed if intermediate platforms are to be used.

Formwork height: 725, 730, 735, 750 and 765 cm

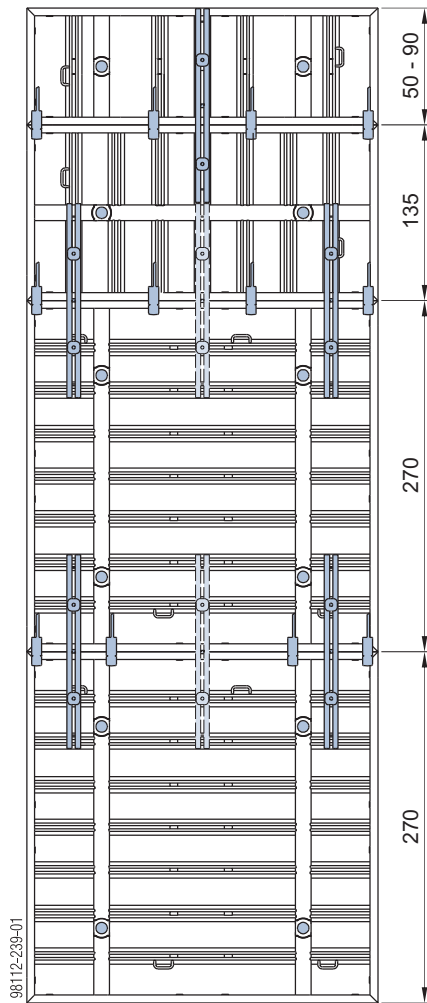

The third universal waling at the first and the second panel joint is only needed if intermediate platforms are to be used.

Formwork height: 810 cm

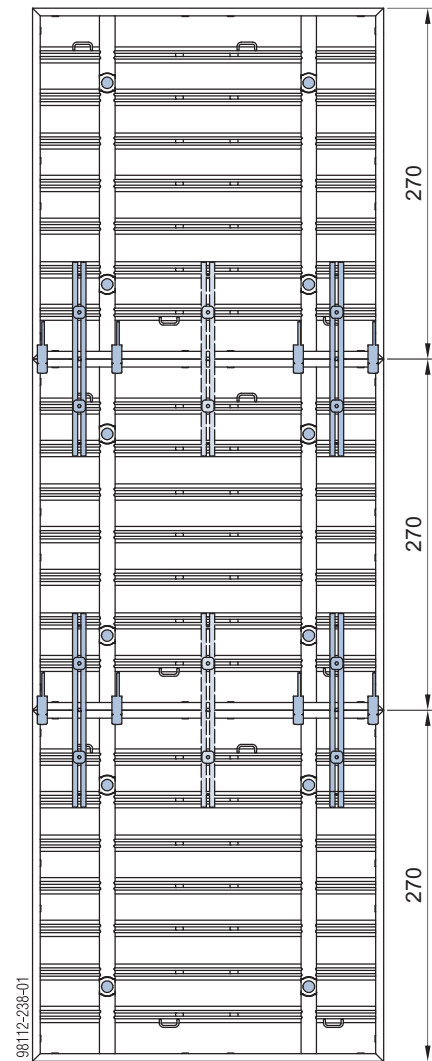

The third universal waling at the first and the second panel joint is only needed if intermediate platforms are to be used.

with Framax quick acting clamp RU

Number of Framax quick acting clamps RU needed at each vertically stacked panel joint

Width of upright panels	Framax quick acting clamp RU
0.30 - 0.55 m	1
0.60 - 1.35 m	2
2.70 m	4

Number of universal walings needed at each vertically stacked panel joint

Formwork height	1st panel joint	2nd panel joint	3rd panel joint
300 - 465 cm	1 ¹⁾	1	—
480 - 630 cm	2	1	—
675 - 735 cm	2 (+1 ²⁾)	2 (+1 ³⁾)	1
750 - 810 cm	3	3	2

The values given in the table apply for a gang-form width of 270 cm.

¹⁾ up to 315 cm not needed when a lightweight pouring platform with single brackets is used.

²⁾ only needed if intermediate platforms are to be used.

³⁾ needed only for height 705 to 735 cm when intermediate platforms are used.

Formwork height: 300 and 315 cm

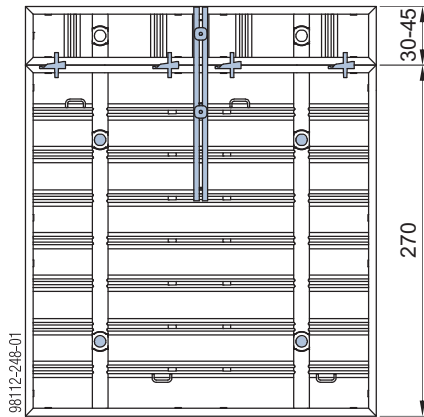

Universal waling only needed if pouring platforms are to be used.

Formwork height: 320, 325, 330, 345, 360 and 405 cm

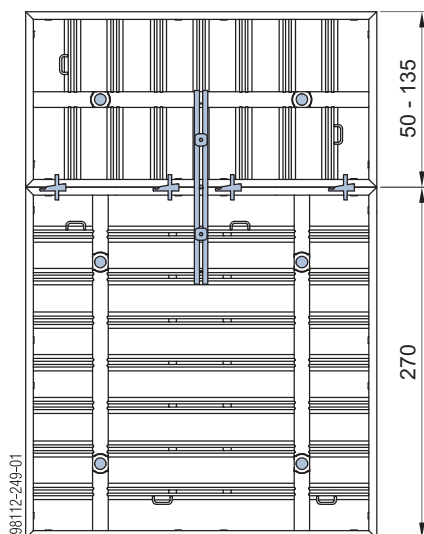

Formwork height: 435 and 450 cm

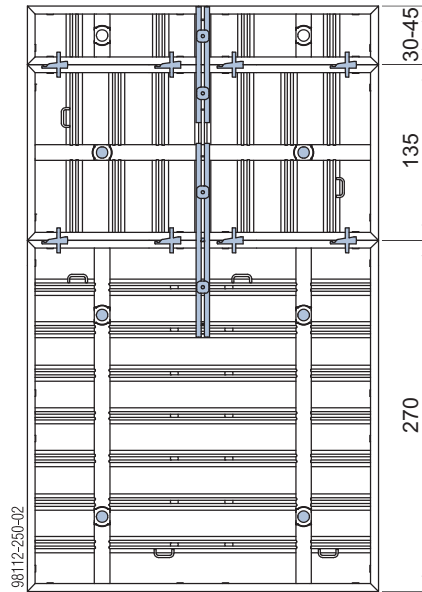

Formwork height: 455, 460 and 465 cm

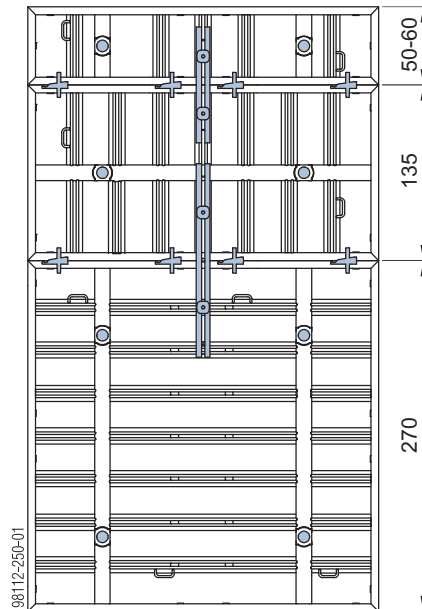

Formwork height: 480 and 495 cm

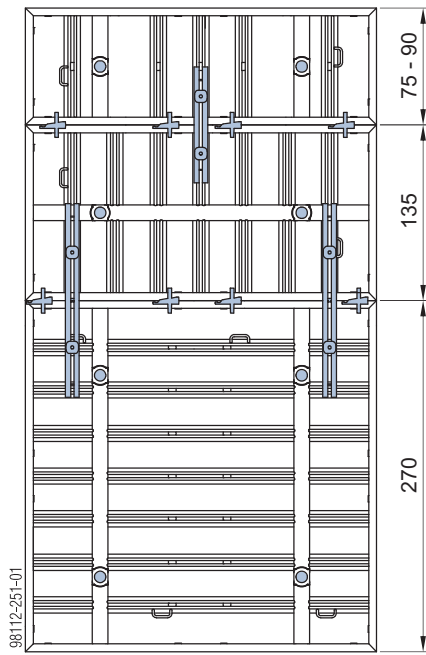

Formwork height: 570 and 585 cm

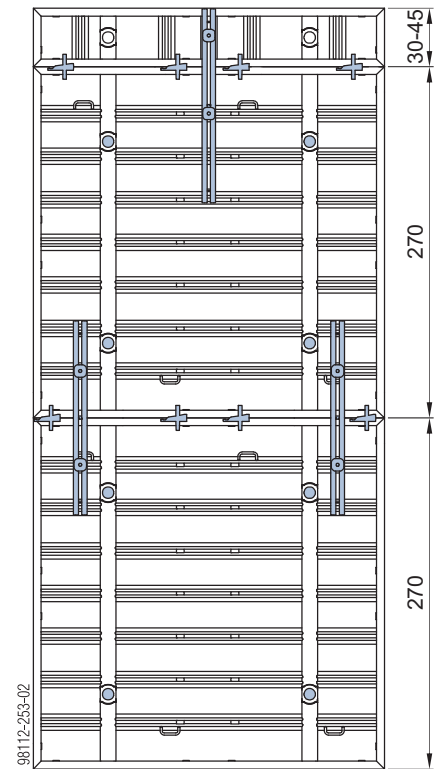

Formwork height: 540 cm

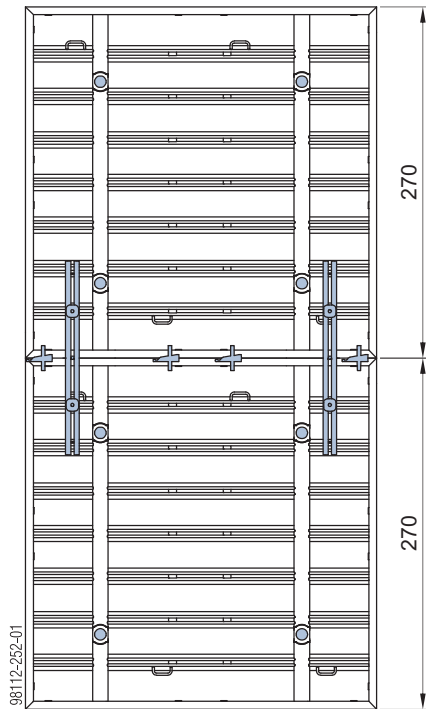

Formwork height: 590, 595, 600, 615 and 630 cm

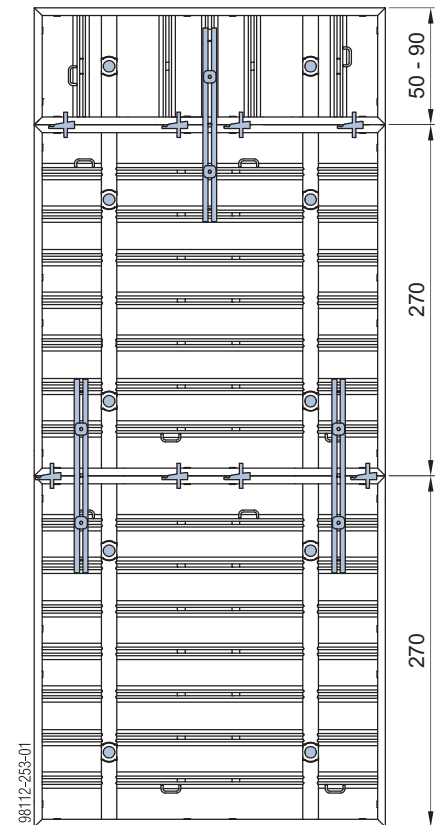

Formwork height: 675 cm

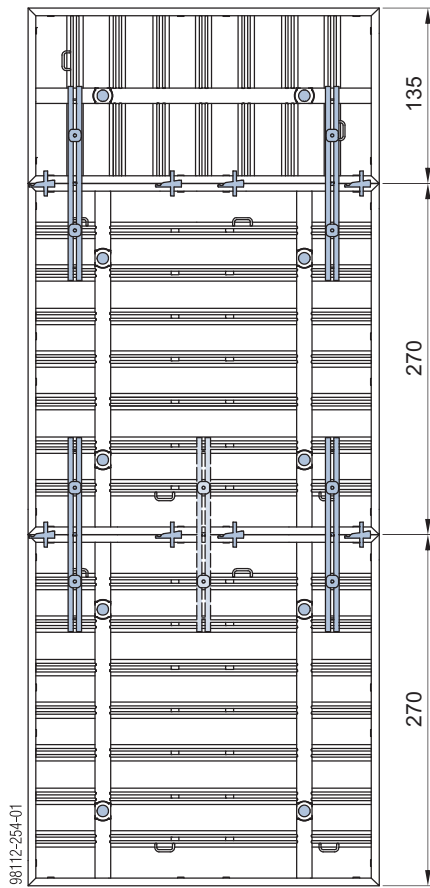

The third universal waling at the first panel joint is only needed if intermediate platforms are to be used.

Formwork height: 705 and 720 cm

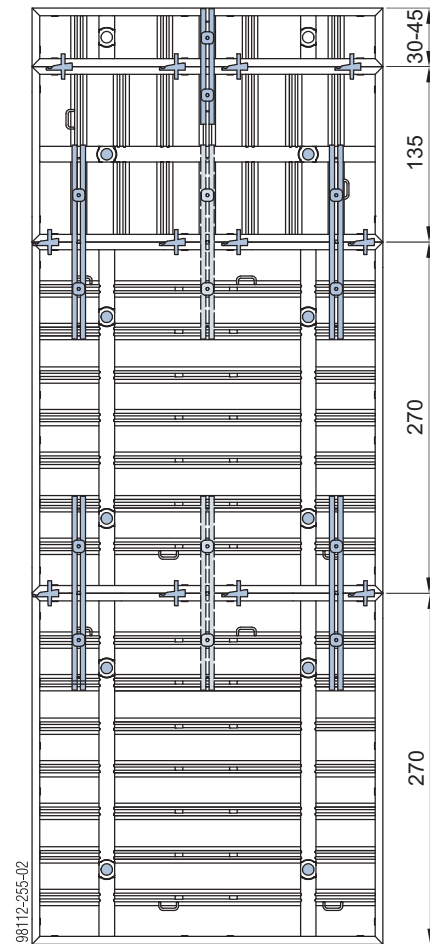

The third universal waling at the first and the second panel joint is only needed if intermediate platforms are to be used.

Formwork height: 725, 730 and 735 cm

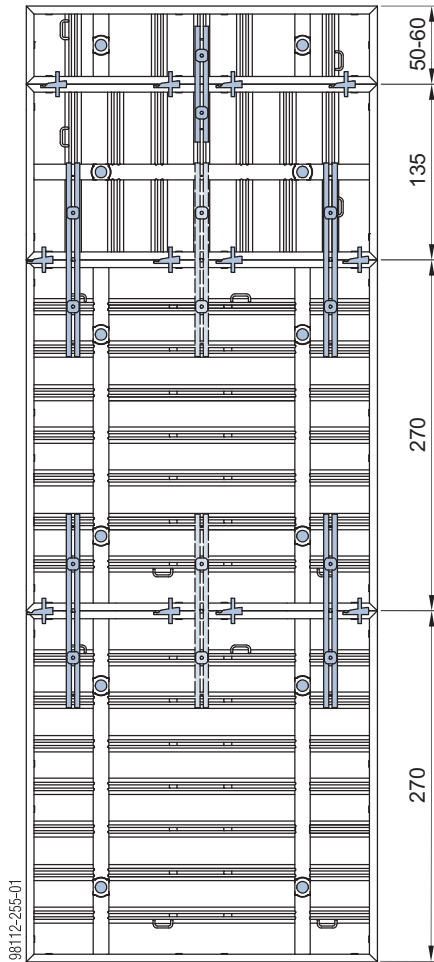

The third universal waling at the first and the second panel joint is only needed if intermediate platforms are to be used.

Formwork height: 750 and 765 cm

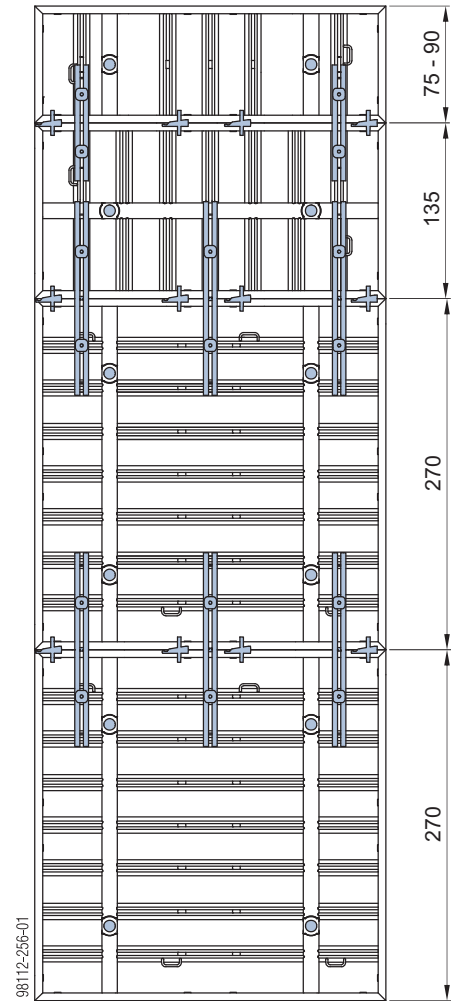

Formwork height: 810 cm

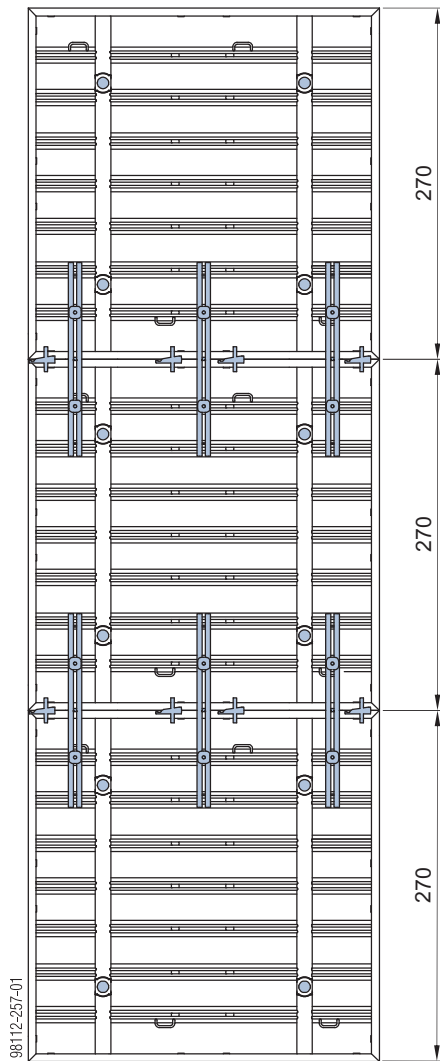

with Framax aligning clamp

Number of Framax aligning clamps needed at each vertically stacked panel joint

Width of upright panels	Framax aligning clamp
0.30 - 0.55m	1
0.60 - 1.35 m	2
2.70m	See graphics

Formwork height: 325, 330, 345, 360 and 405 cm

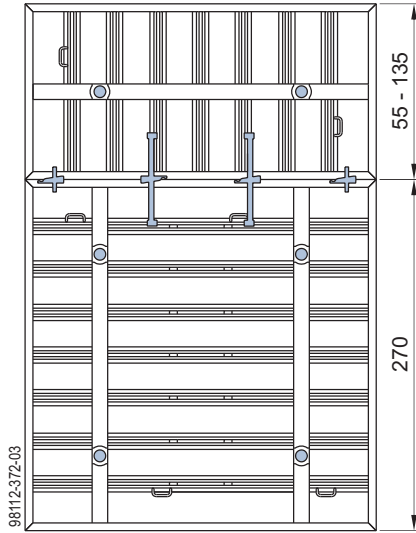

Formwork height: 540 cm

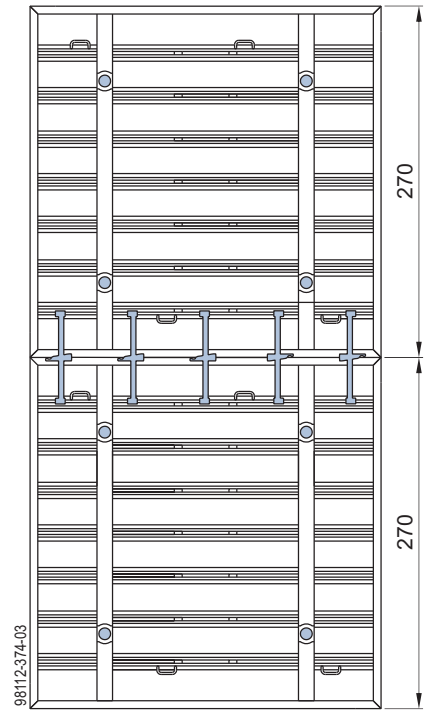

Formwork height: 460, 465, 480 and 495 cm

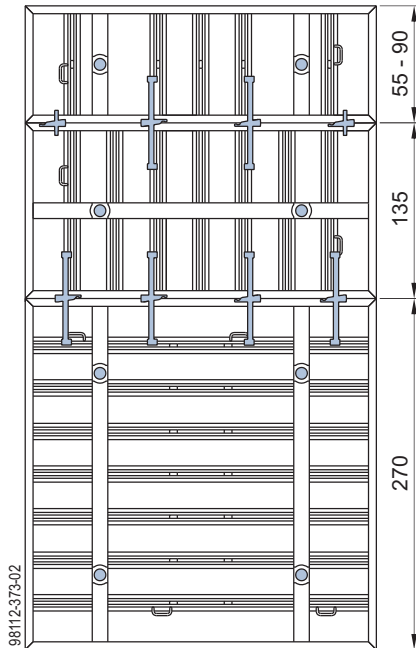

Framax Xlife plus panel 3.00m

with Framax multi function clamp

Number of Framax multi function clamps needed at each vertically stacked panel joint

Width of upright panels	Framax multi function clamp
0.30 - 0.55 m	1
0.60 - 1.35 m	2
2.70 m	4 (+1 *)

*) 2nd inter-panel joint without universal waling.

Number of universal walings needed at each vertically stacked panel joint

Formwork height	1st panel joint	2nd panel joint
330 - 525 cm	1 ¹⁾	—
570 - 720 cm	2 (+1 ²⁾)	1
735 - 765 cm	3	2

The values given in the table apply for a gang-form width of 270 cm.

¹⁾ up to 375 cm not needed when a lightweight pouring platform with single brackets is used.

²⁾ needed only for height 630 to 720 cm when intermediate platforms are used.

Permitted fresh-concrete pressure **75kN/m²** on 3.00m high panels.

Formwork height: 330 and 345 cm

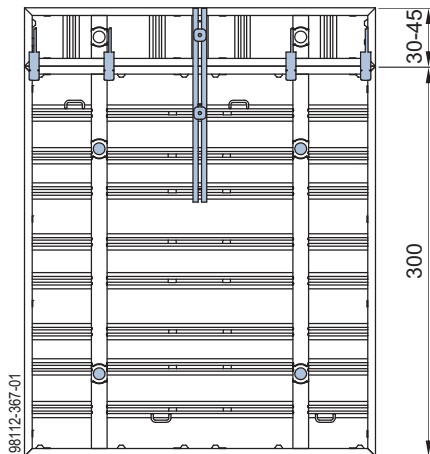

When using a lightweight pouring platform with single brackets (Framax bracket 90), the universal waling is not necessary.

Formwork height: 350, 355, 360 and 375 cm

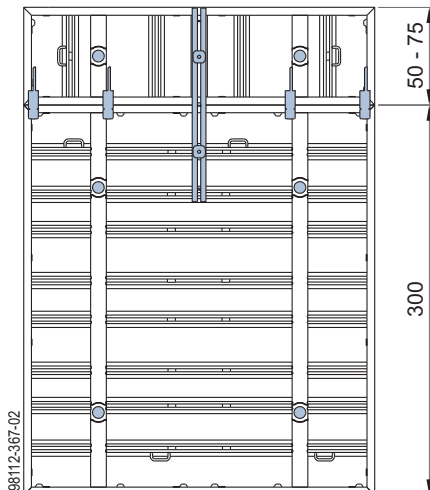

When using a lightweight pouring platform with single brackets (Framax bracket 90), the universal waling is not necessary.

Formwork height: 390 and 435 cm

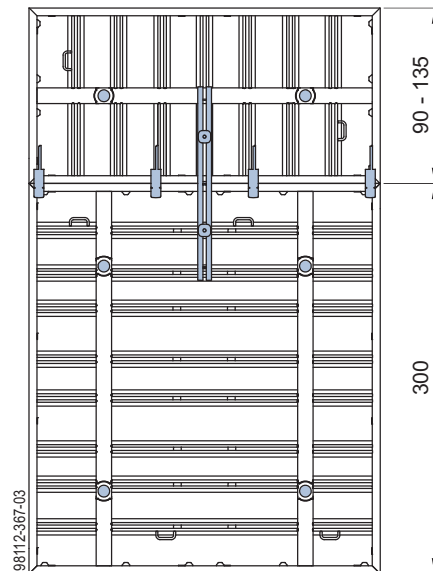

Formwork height: 465 and 480 cm

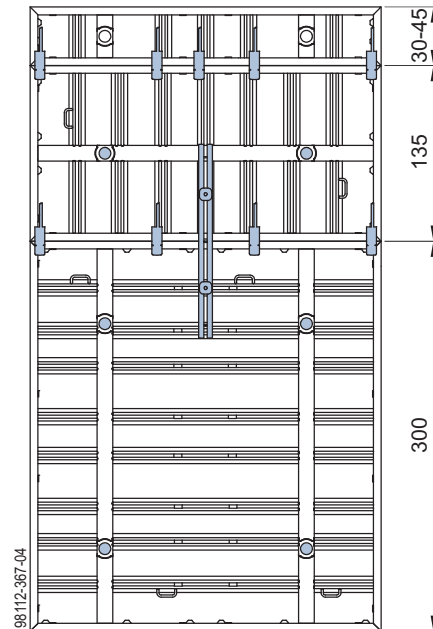

Formwork height: 485, 490, 495, 510 and 525 cm

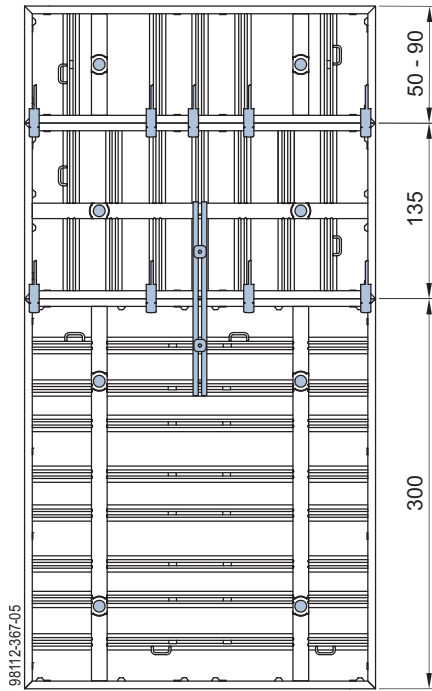

Formwork height: 600 and 615 cm

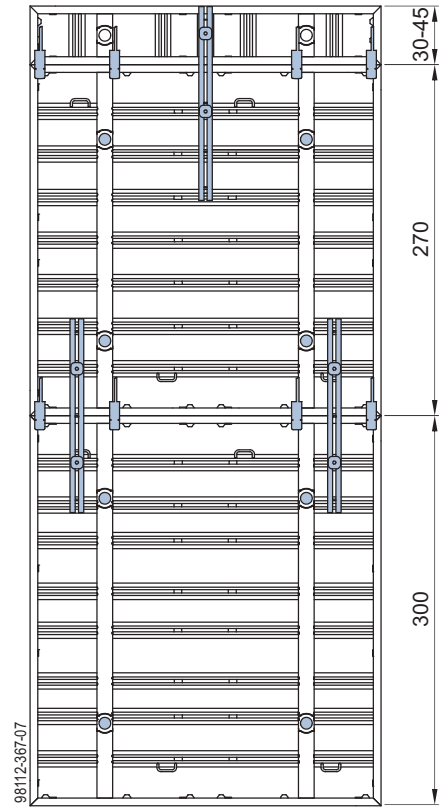

Formwork height: 570 cm

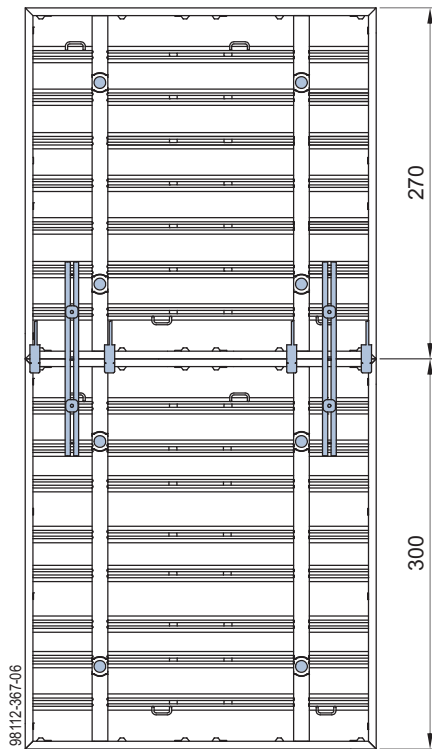

The topmost universal waling is not needed if a light pouring platform made of single brackets (Framax bracket 90) is to be used.

Formwork height: 600 and 630

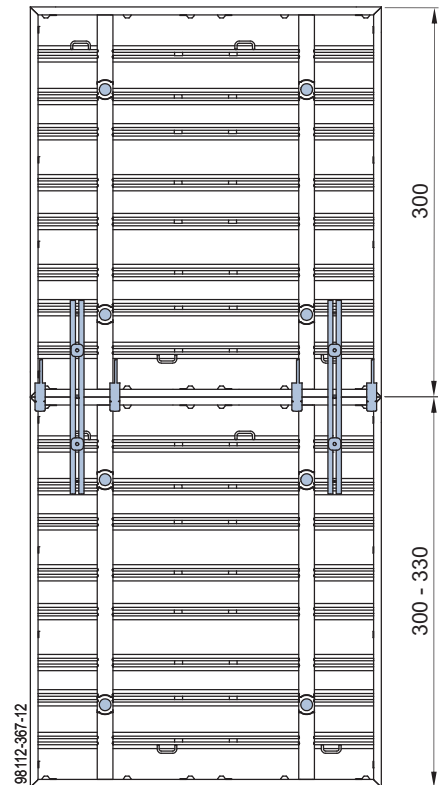

Formwork height: 630, 645, 660 and 675 cm

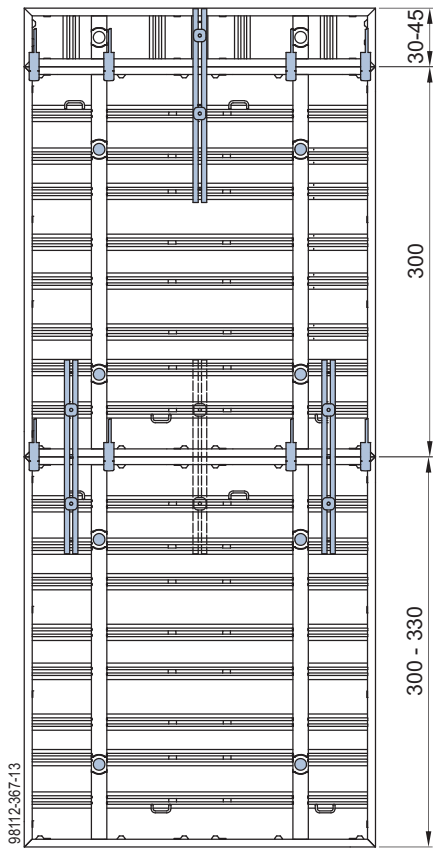

The third universal waling is needed only if intermediate platforms are to be used.

Formwork height: 735 and 765 cm

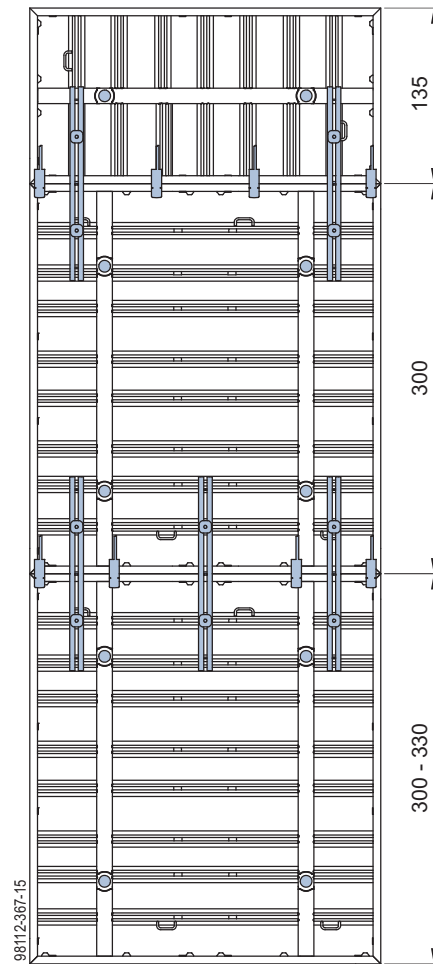

Formwork height: 650, 655, 660, 675, 680, 685, 690, 705 and 720 cm

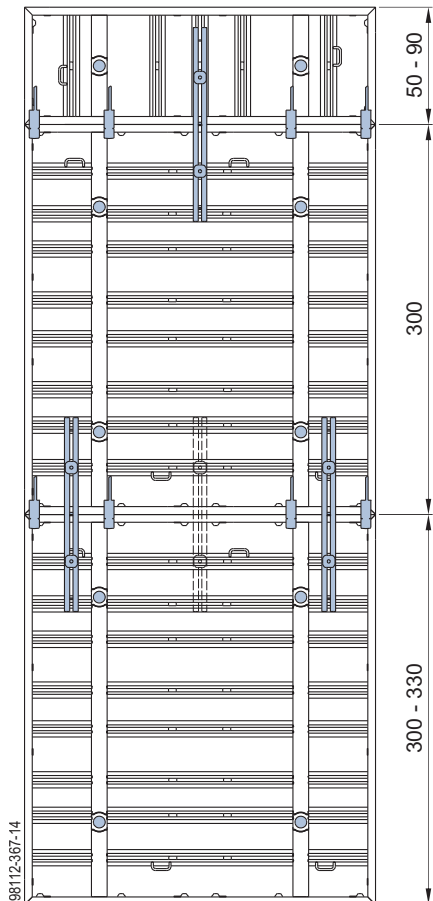

The third universal waling is needed only if intermediate platforms are to be used.

with Framax quick acting clamp RU

Number of Framax quick acting clamps RU needed at each vertically stacked panel joint

Width of upright panels	Framax quick acting clamp RU
0.30 - 0.55 m	1
0.60 - 1.35 m	2
2.70 m	4

Number of universal walings needed at each vertically stacked panel joint

Formwork height	1st panel joint	2nd panel joint
330 - 480 cm	1 ¹⁾	1
485 - 720 cm	2 (+1 ²⁾)	1
735 - 765 cm	3	2

The values given in the table apply for a gang-form width of 270 cm.

¹⁾ up to 345 cm not needed when a lightweight pouring platform with single brackets is used.

²⁾ needed only for height 630 to 720 cm when intermediate platforms are used.

Permitted fresh-concrete pressure **75kN/m²** on 3.00m high panels.

Formwork height: 465 and 480 cm

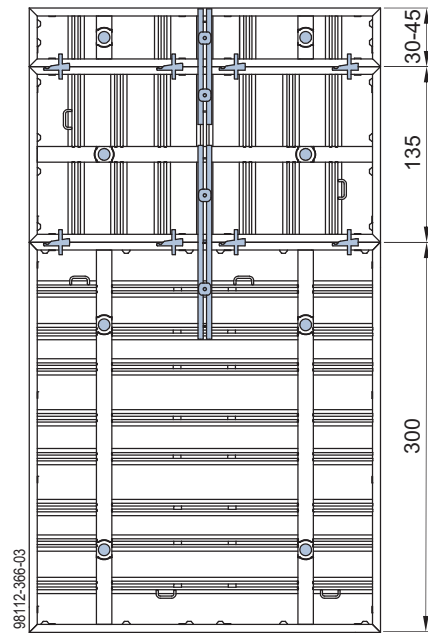

Formwork height: 485, 490, 495, 510 and 525 cm

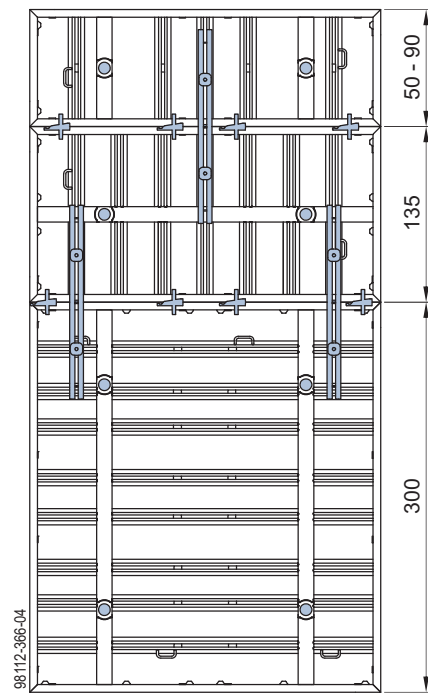

Formwork height: 330 and 345 cm

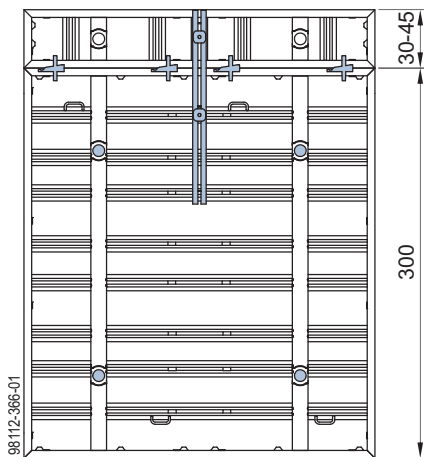

Universal waling only needed if pouring platforms are to be used.

Formwork height: 350, 355, 360, 375, 390 and 435 cm

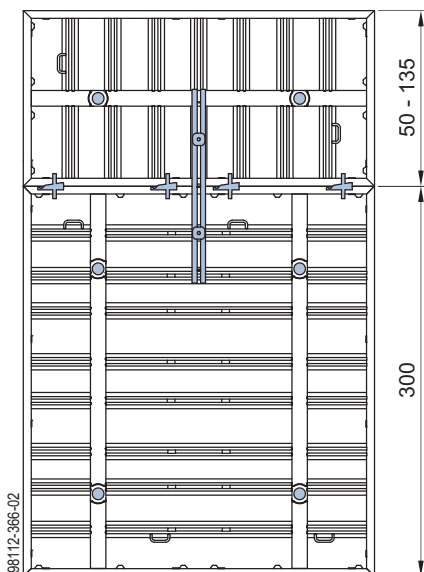

Formwork height: 570 cm

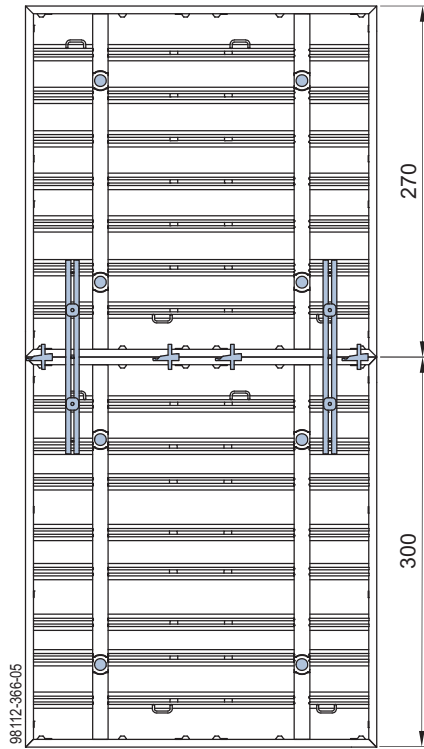

Formwork height: 600 and 630 cm

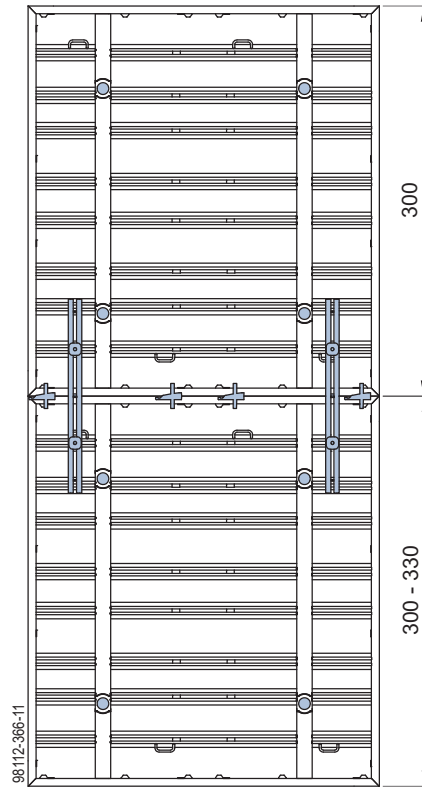

Formwork height: 600 and 615 cm

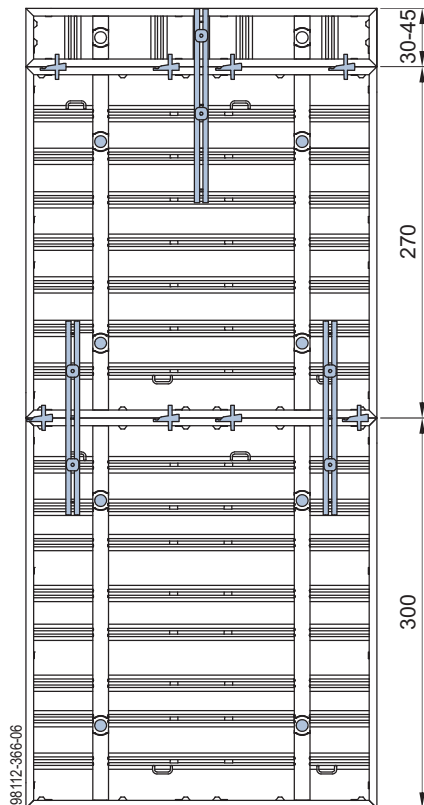

Formwork height: 630, 645, 660 and 675 cm

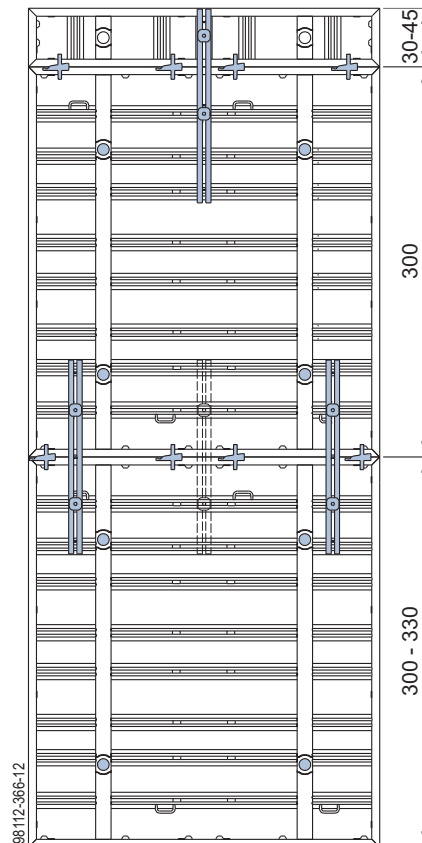

The third universal waling is needed only if intermediate platforms are to be used.

Formwork height: 650, 655, 660, 675, 680, 685, 690, 705 and 720 cm

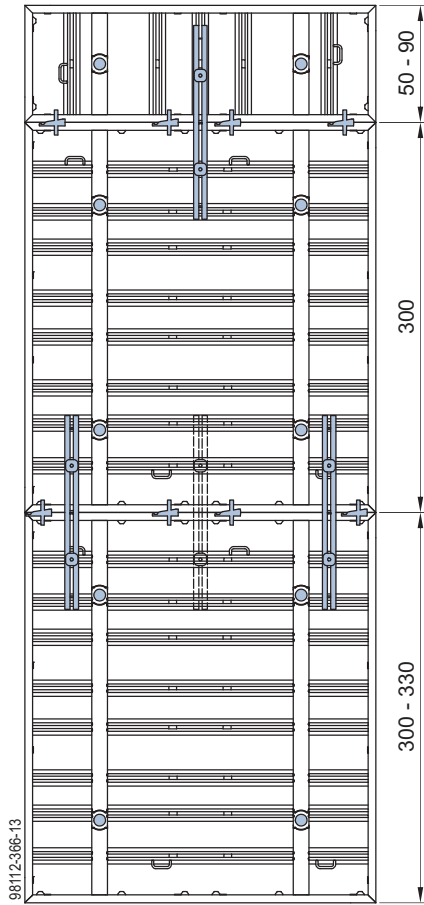

Formwork height: 735 and 765 cm

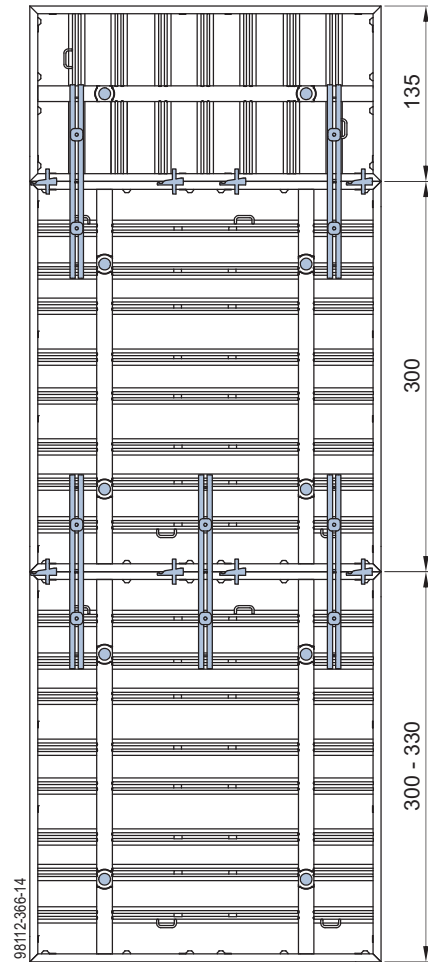

The third universal waling is needed only if intermediate platforms are to be used.

with Framax aligning clamp

Number of Framax aligning clamps needed at each vertically stacked panel joint

Width of upright panels	Framax aligning clamp
0.30 - 0.55m	1
0.60 - 1.35m	2
2.70m	See graphics

Permitted fresh-concrete pressure **75kN/m²** on 3.00m high panels.

Formwork height: 355, 360, 375, 390 and 435 cm

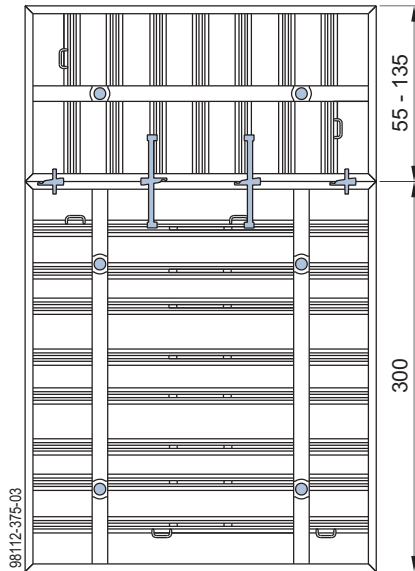

Formwork height: 570 cm

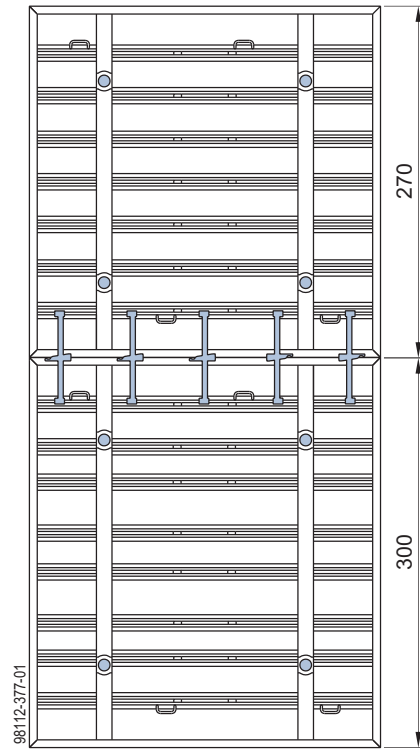

Formwork height: 490, 495, 510 and 525 cm

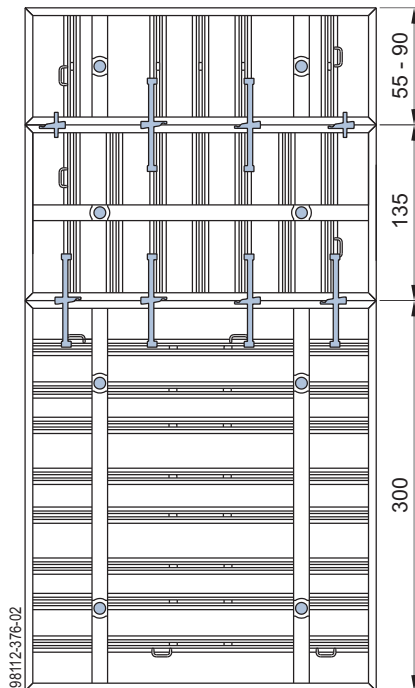

Framax Xlife plus panel 3.30m

with Framax multi function clamp

Number of Framax multi function clamps needed at each vertically stacked panel joint

Width of upright panels	Framax multi function clamp
0.30 - 0.55 m	1
0.60 - 1.35 m	2
2.70 m	4 (+1 *)

*) 2nd inter-panel joint without universal waling.

Number of universal walings needed at each vertically stacked panel joint

Formwork height	1st panel joint	2nd panel joint
360 - 555 cm	1 ¹⁾	—
600 - 750 cm	2 (+1 ²⁾)	1
795 cm	3	2

The values given in the table apply for a gang-form width of 270 cm.

¹⁾ up to 405 cm not needed when a lightweight pouring platform with single brackets is used.

²⁾ needed only for height 690 to 750 cm when intermediate platforms are used.

Formwork height: 360 and 375 cm

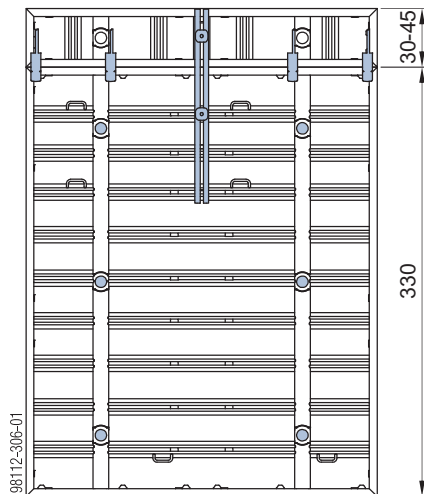

When using a lightweight pouring platform with single brackets (Framax bracket 90), the universal waling is not necessary.

Formwork height: 380, 385, 390 and 405 cm

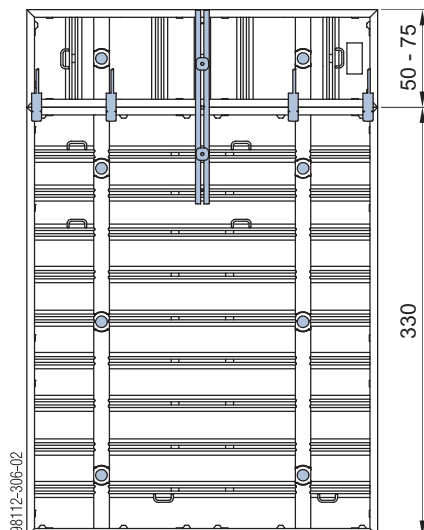

When using a lightweight pouring platform with single brackets (Framax bracket 90), the universal waling is not necessary.

Formwork height: 420 and 465 cm

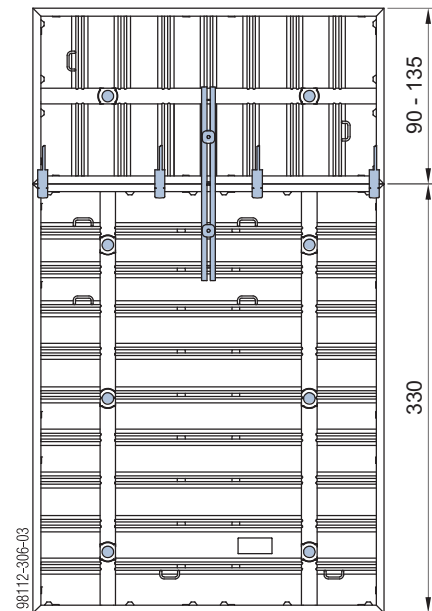

Formwork height: 495 and 510 cm

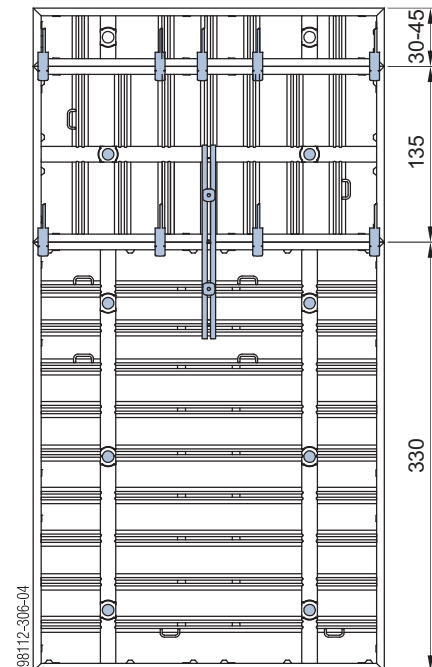

Formwork height: 515, 520, 525, 540 and 555 cm

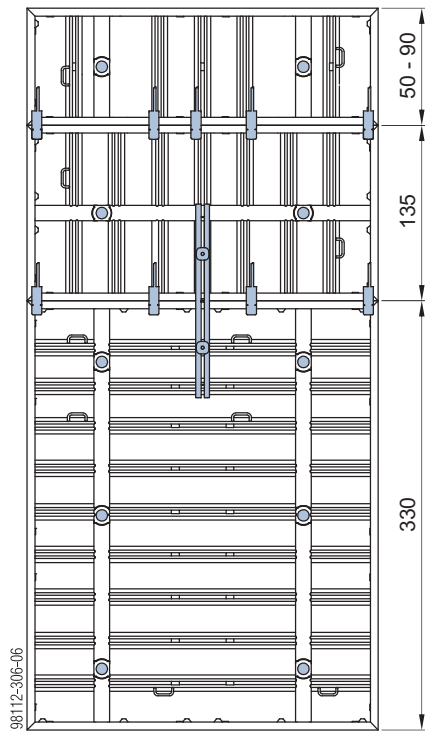

Formwork height: 630 and 645 cm

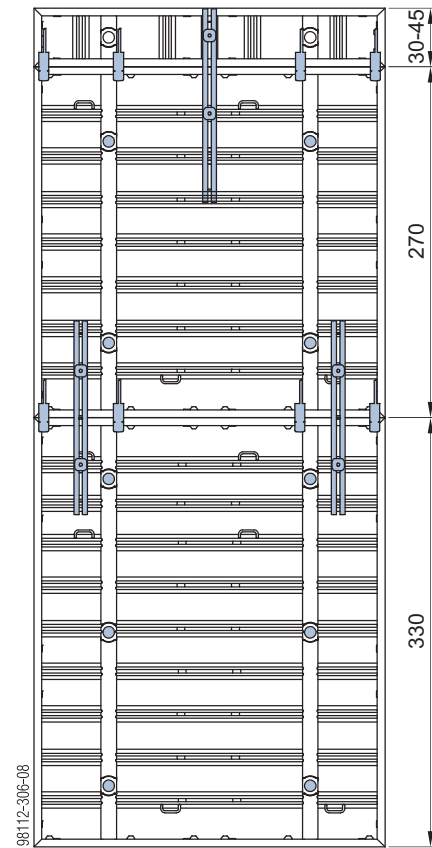

Formwork height: 600 cm

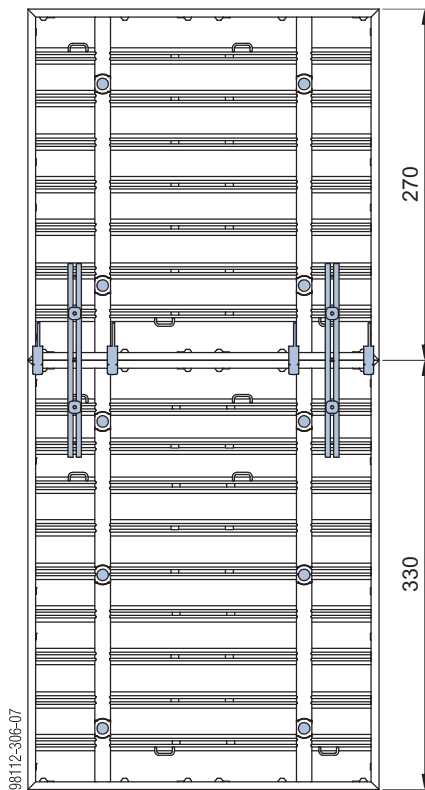

The topmost universal waling is not needed if a light pouring platform made of single brackets (Framax bracket 90) is to be used.

Formwork height: 660 cm

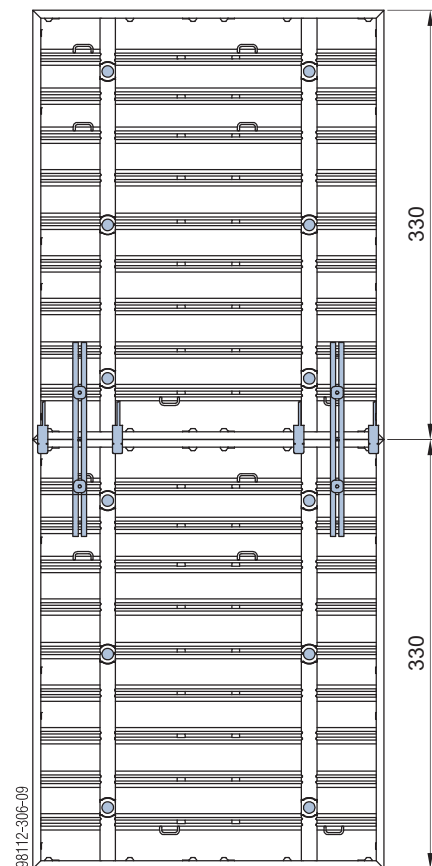

Formwork height: 690 and 705 cm

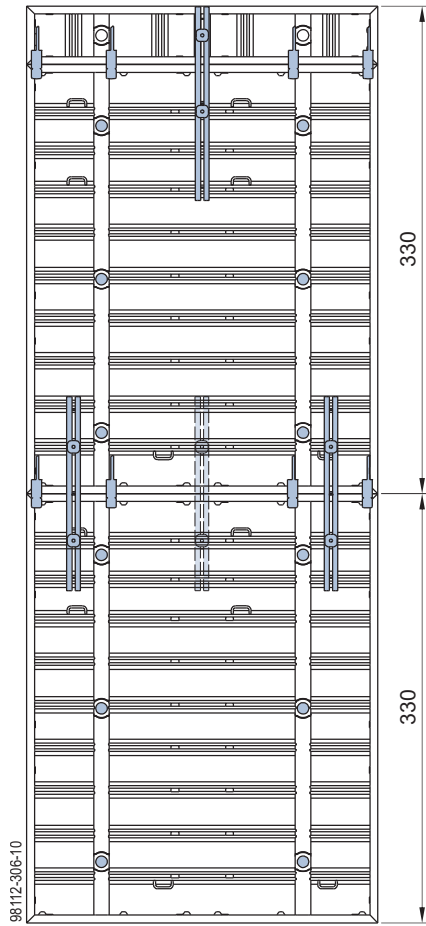

The third universal waling is needed only if intermediate platforms are to be used.

Formwork height: 710, 715, 720, 735 and 750 cm

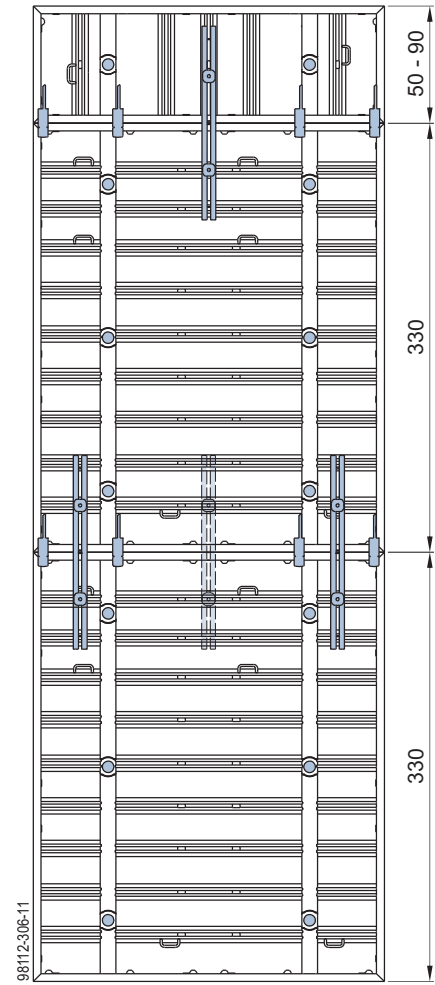

The third universal waling is needed only if intermediate platforms are to be used.

Formwork height: 795 cm

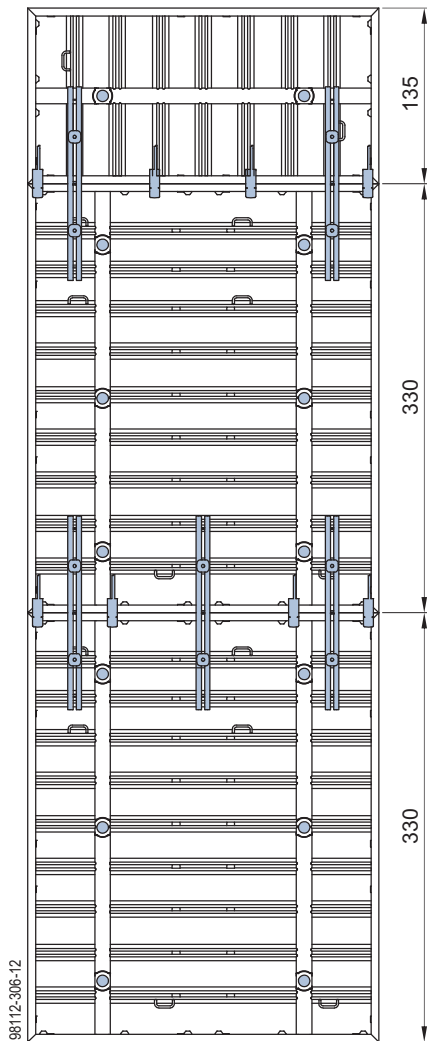

with Framax quick acting clamp RU

Number of Framax quick acting clamps RU needed at each vertically stacked panel joint

Width of upright panels	Framax quick acting clamp RU
0.30 - 0.55 m	1
0.60 - 1.35 m	2
2.70 m	4

Number of universal walings needed at each vertically stacked panel joint

Formwork height	1st panel joint	2nd panel joint
360 - 510 cm	1 ¹⁾	1
515 - 750 cm	2 (+1 ²⁾)	1
795 cm	3	2

The values given in the table apply for a gang-form width of 270 cm.

¹⁾ up to 375 cm not needed when a lightweight pouring platform with single brackets is used.

²⁾ needed only for height 690 to 750 cm when intermediate platforms are used.

Formwork height: 360 and 375 cm

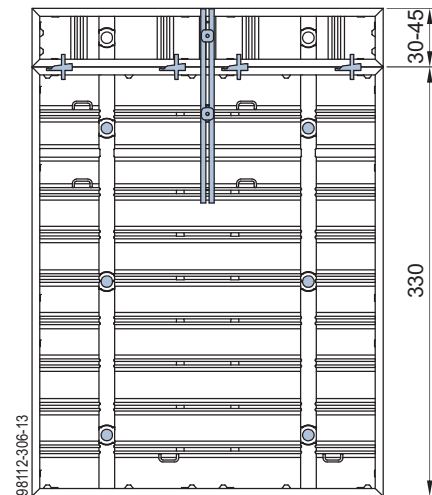

Universal waling only needed if pouring platforms are to be used.

Formwork height: 380, 385, 390, 405, 420 and 465 cm

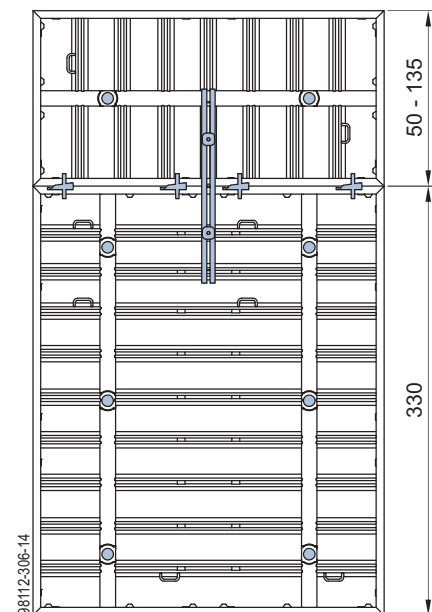

Formwork height: 495 and 510 cm

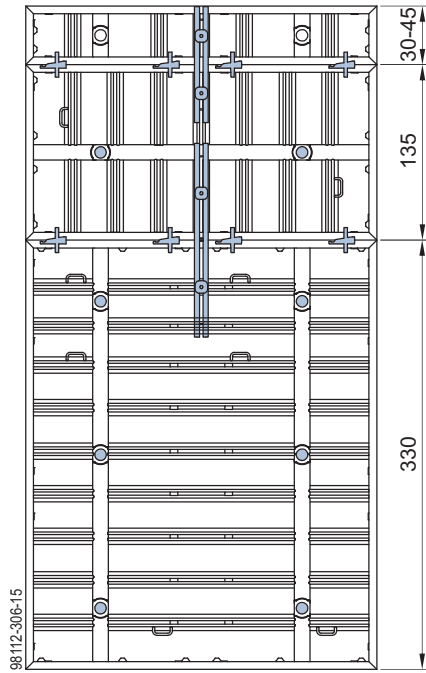

Formwork height: 600 cm

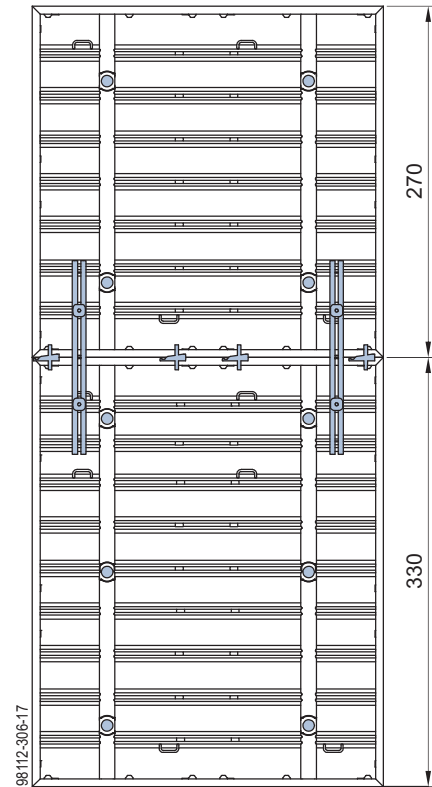

Formwork height: 515, 520, 525, 540 and 555 cm

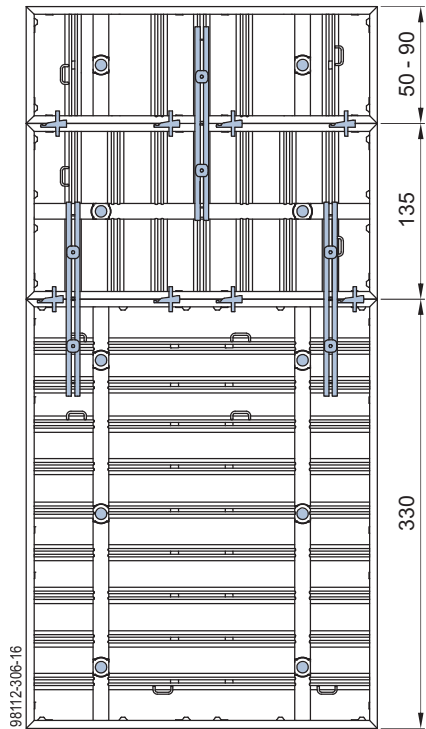

Formwork height: 630 and 645 cm

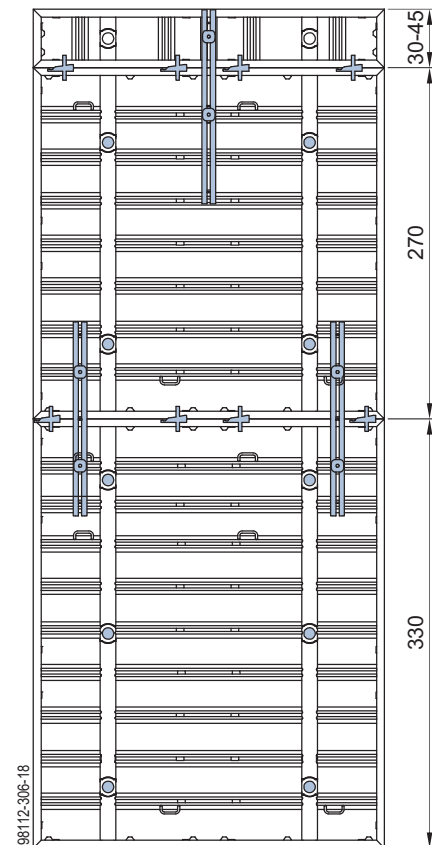

Formwork height: 660 cm

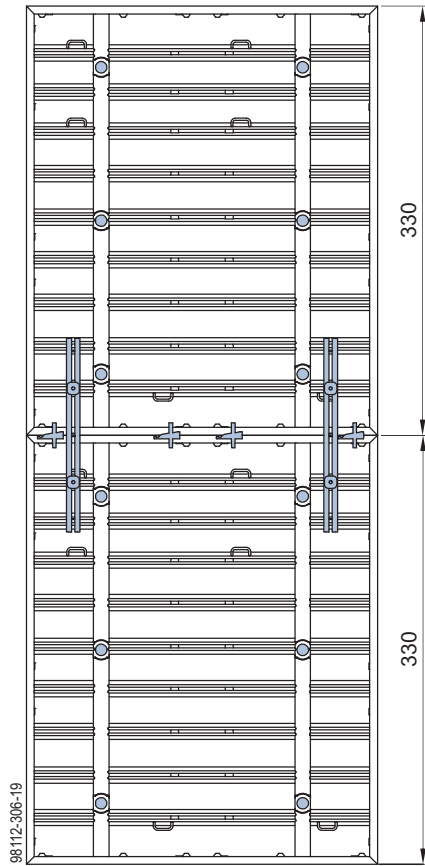

Formwork height: 710, 715, 720, 735 and 750 cm

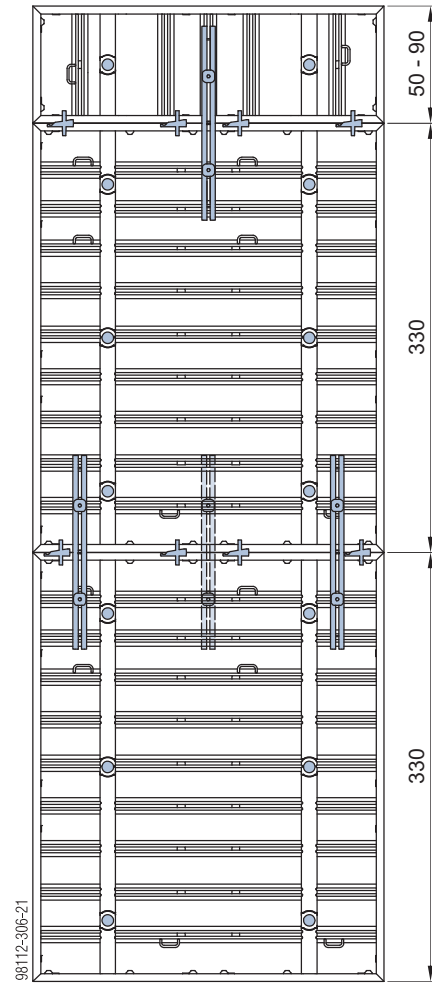

Formwork height: 690 and 705 cm

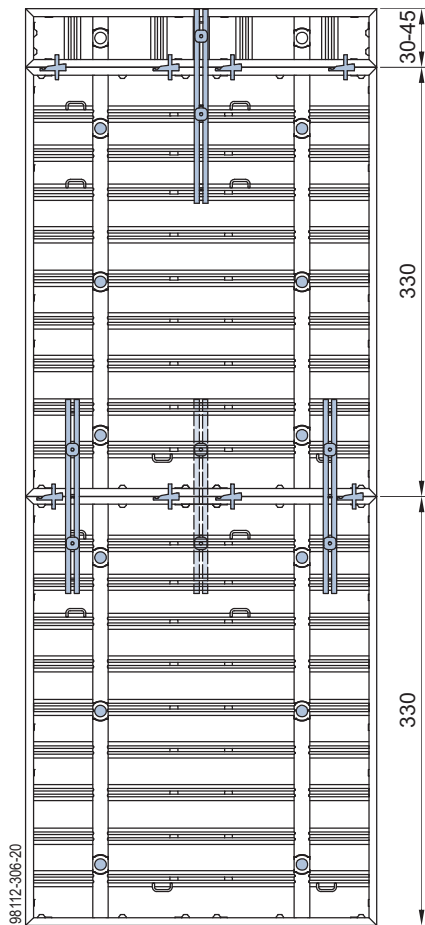

The third universal waling is needed only if intermediate platforms are to be used.

The third universal waling is needed only if intermediate platforms are to be used.

Formwork height: 795 cm

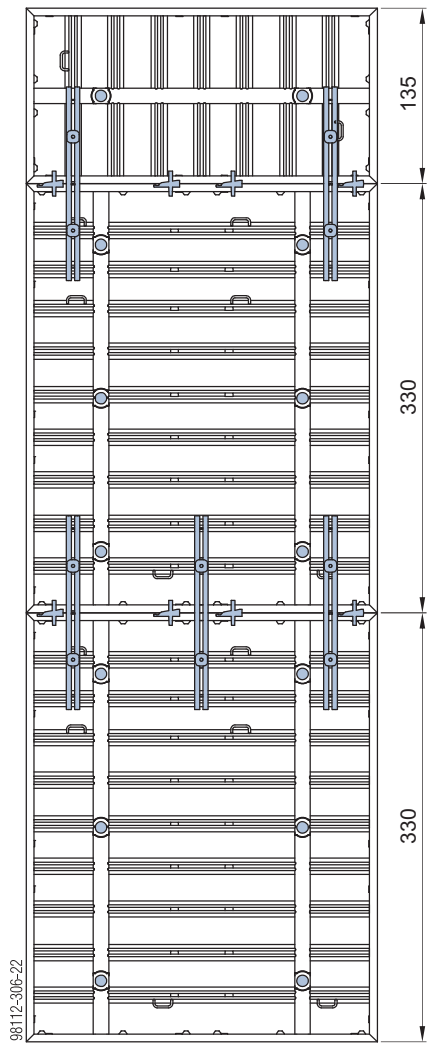

with Framax aligning clamp

Formwork height: 600 cm

Number of Framax aligning clamps needed at each vertically stacked panel joint

Width of upright panels	Framax aligning clamp
0.30 - 0.55m	1
0.60 - 1.35m	2
2.70m	See graphics

Formwork height: 385, 390, 405, 420 and 465 cm

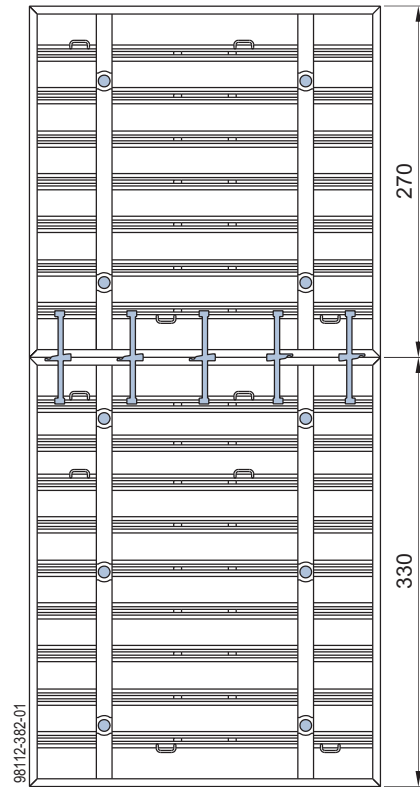
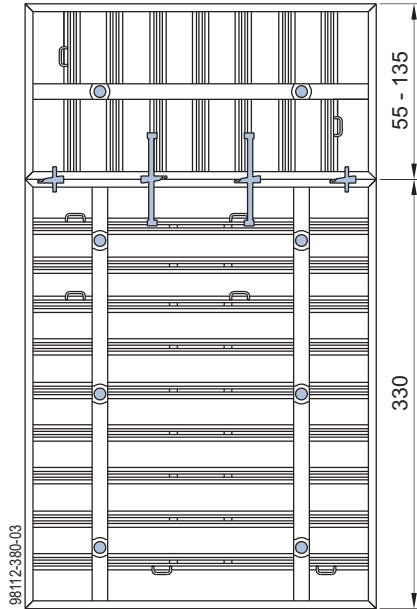

Formwork height: 520, 525, 540 and 555 cm

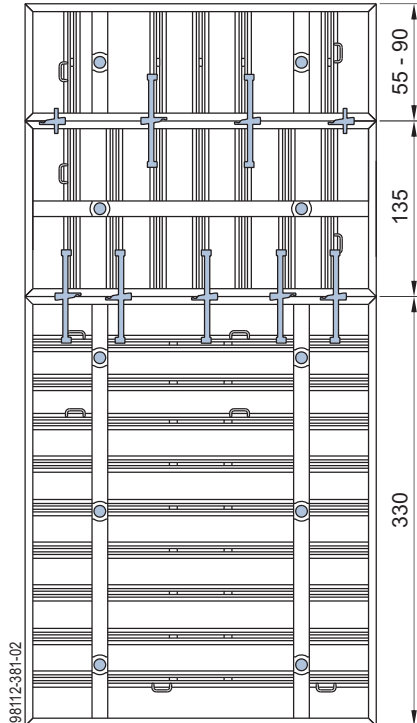

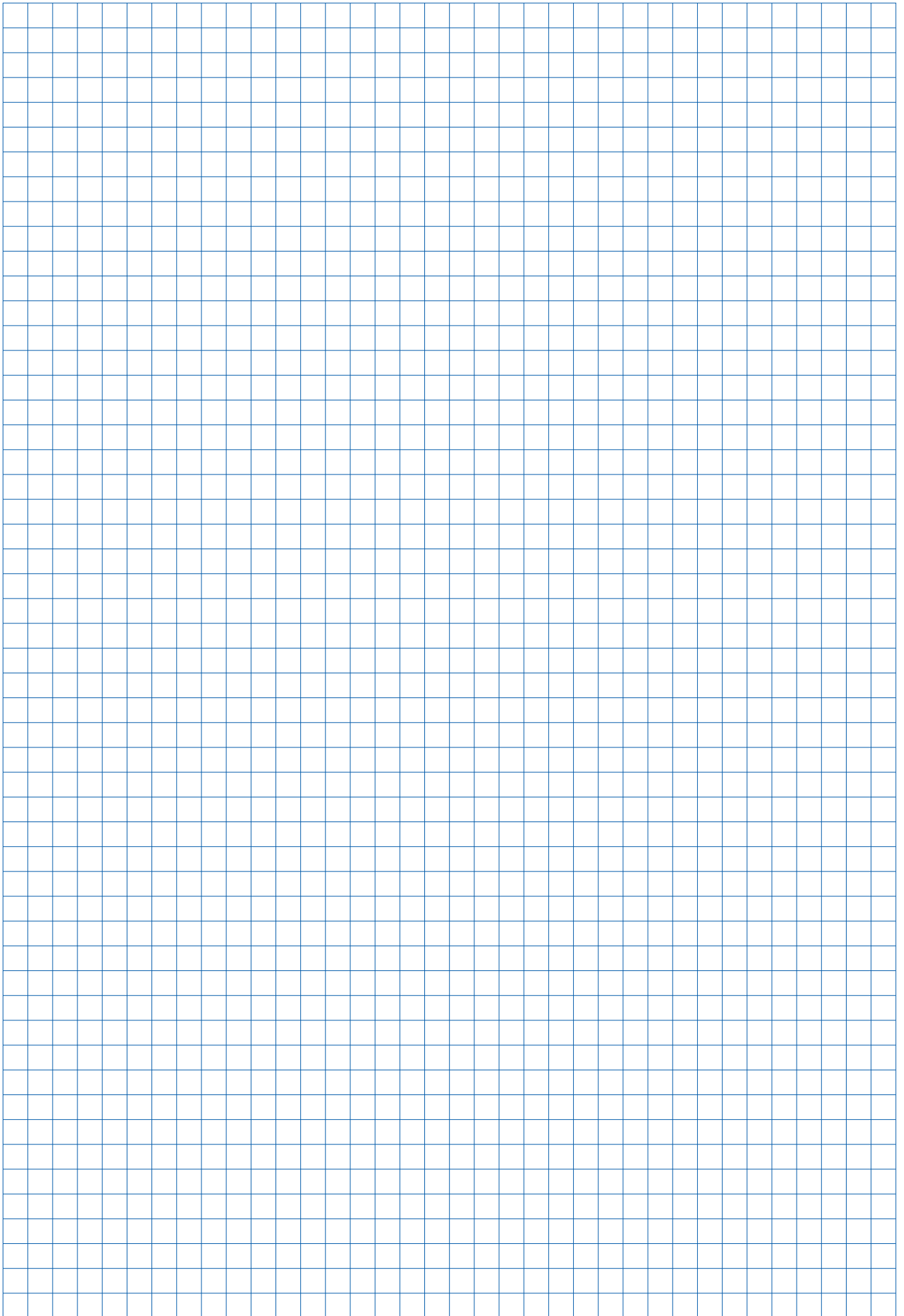

Tie rod system Framax Xlife plus

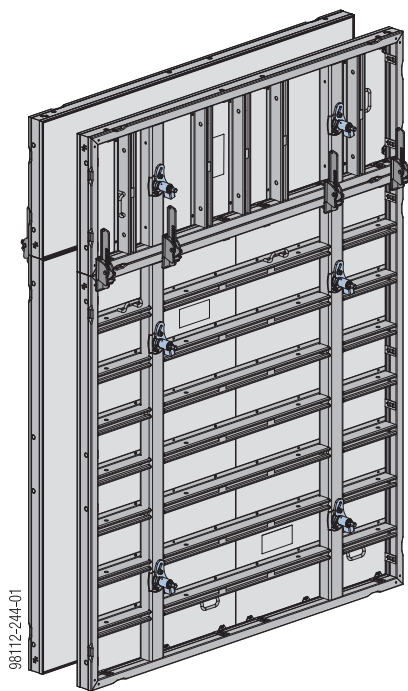

The **Framax Xlife plus ratchet 3/4" SW24** or the **Framax Xlife plus ratchet 1/2" SW24 L** can be used for low-noise releasing and tightening of all form-tie components.



WARNING

Delicate rod steel!

- Never weld or heat tie rods.
- Tie rods that are damaged or have been weakened by corrosion or wear must be withdrawn from use.

Inclination of panels and mismatch between panels

Thanks to their large anchoring sleeves, the panels can be inclined on one or both sides, and be mismatched.

Close-up of the Framax Xlife plus form-tie nut I 20.0

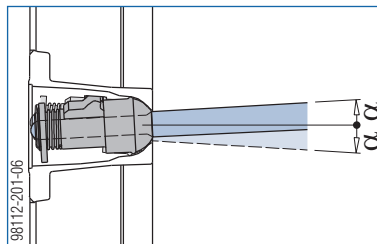

α ...max. 4°

Tie rod system Framax Xlife plus 20.0:

- can be operated from one side
- for wall thicknesses from 15 cm to 40 cm
- no lost jacket tubes



NOTICE

- Fit one form tie in each anchoring sleeve.
- For exceptions, see sections:
 - [Framax head anchor 15-40cm](#)
 - [90 degree corners](#)
 - [Acute & obtuse-angled corners](#)

Note:

Seal off any unneeded anchoring sleeves with the **Framax Xlife plus frame hole plug 32mm NG**.

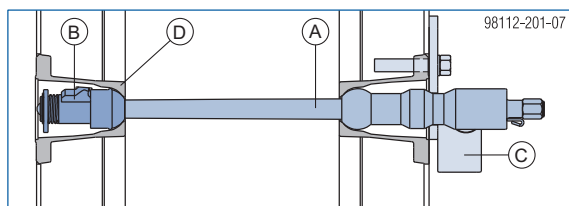

- A** Framax Xlife plus form tie 20.0
- B** Framax Xlife plus form-tie nut I 20.0
- C** Framax Xlife plus distance protector NG
- D** Anchoring sleeve inside the framed formwork panel

	Wall thicknesses in 0.5 cm increments
Framax Xlife plus form tie 20.0 15-30cm	15 to 30 cm
Framax Xlife plus form tie 20.0 25-40cm	25 to 40 cm

Framax Xlife plus form tie 20.0:
Permissible load-bearing capacity: 152 kN

Conical on one side max. 4°	Conical on both sides max. 2 x 4°	Mismatch between panels max. 1.0 cm per 15 cm of wall thickness
98112-245-01	98112-245-02	98112-245-03

Note:

Secure inclined panels against uplift.

Adjusting to the wall thickness

Setting the form tie

- ▶ Remove the spring clip.
- ▶ Push the ball pin away from the stop cylinder.

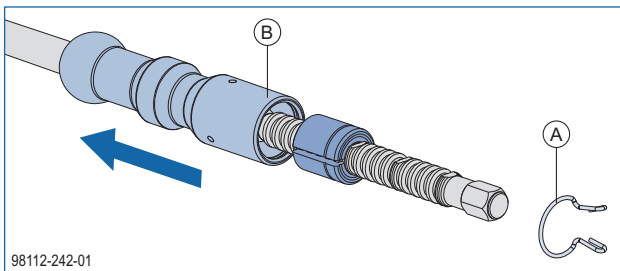

- A Spring clip
- B Ball pin



Turning the ball pin makes it easier to push it away.

- ▶ Open the stop cylinder and position it.

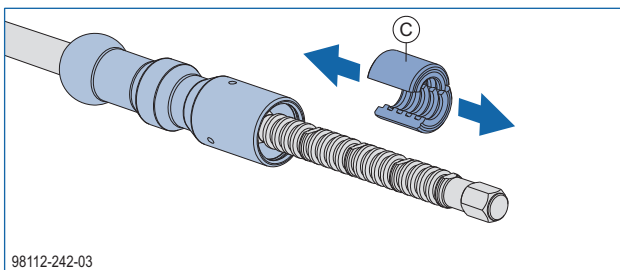

- C Stop cylinder

- ▶ Push the ball pin back over the stop cylinder.
- ▶ Secure the ball pin with the spring clip.

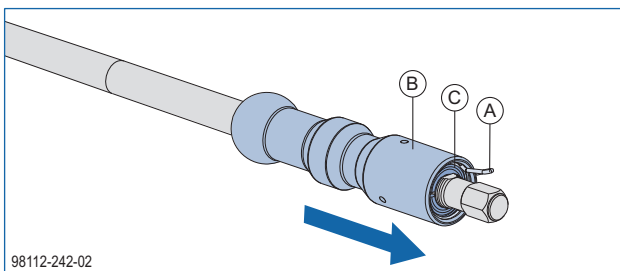

- A Spring clip
- B Ball pin
- C Stop cylinder

Wall thicknesses of between 15.0 cm and 40.0 cm, in 1 cm increments

Standard position of the stop cylinder

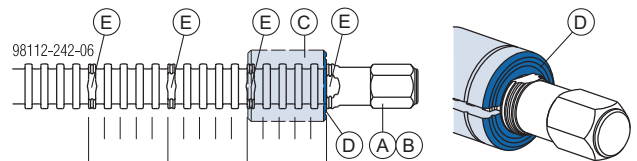

A	15.0	20.0	25.0	30.0
B	25.0	30.0	35.0	40.0

- A Framax Xlife plus form tie 15-30cm
- B Framax Xlife plus form tie 25-40cm
- C Stop cylinder
- D Coloured mark and marking groove
- E Wall thickness indicator

Example: Wall thickness = 22.0 cm

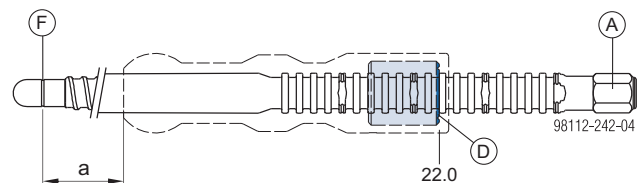

a ... 32.0 cm (wall thickness + 10.0 cm)

- A Framax Xlife plus form tie 15-30cm
- D Coloured mark and marking groove
- F Control marking on the tie rod

Wall thicknesses of between 15.5 cm and 40.5 cm, in 1 cm increments

Stop cylinder, turned 180°

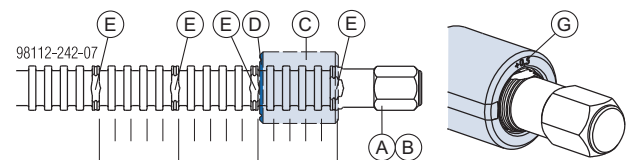

A	15.5	20.5	25.5	30.5
B	25.5	30.5	35.5	40.5

- A Framax Xlife plus form tie 15-30cm
- B Framax Xlife plus form tie 25-40cm
- C Stop cylinder
- D Coloured mark and marking groove
- E Wall thickness indicator
- G '+0.5' marking on the stop cylinder

Example: Wall thickness = 36.5 cm

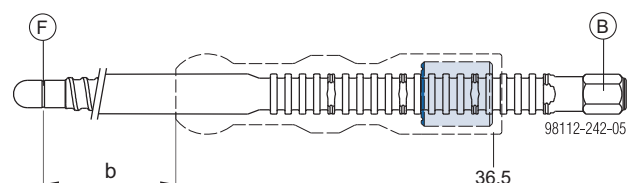

b ... 46.5 cm (wall thickness + 10.0 cm)

- B Framax Xlife plus form tie 25-40cm
- F Control marking on the tie rod

Securing the distance

The Framax Xlife plus form ties do not need any jacket tubes. For this reason, at least the upper form-tie points must be fitted with distance protectors for pressure bracing.

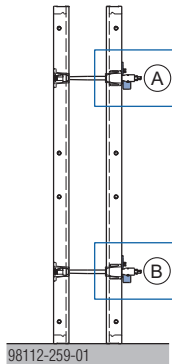

- A** Framax Xlife plus distance protector NG **required**
- B** Framax Xlife plus distance protector NG optional

Tying the panels



NOTICE

Before each use, spray the concrete-contacting part of the form tie with release agent! This ensures subsequent detachment from the concrete.

1st formwork half (e.g. holding formwork)

- Position the form-tie nut into the anchoring sleeve of the framed formwork panel.

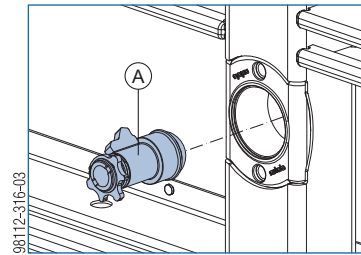

The hook of the form-tie nut engages in the recess of the anchoring sleeve.

- Push the centring disc in and at the same time turn it through 180°.

Position of the centring disc:

can be installed and removed

fixed in place

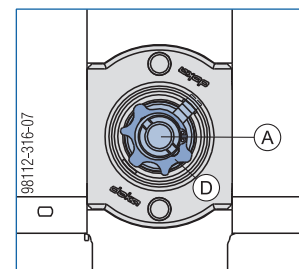
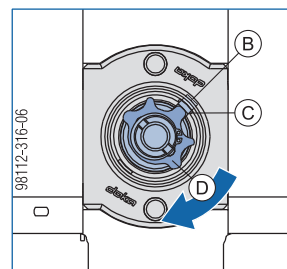

- A** Framax Xlife plus form-tie nut I 20.0
- B** Hook
- C** Recess
- D** Centring disc

Centring disc engages. Form-tie nut is fixed in place.

2nd formwork half (e.g. opposing formwork)

- ▶ Set up the opposing formwork.
- ▶ Mount the distance protector at the form-tie point (do not tighten the screw yet), and tilt it to the left.

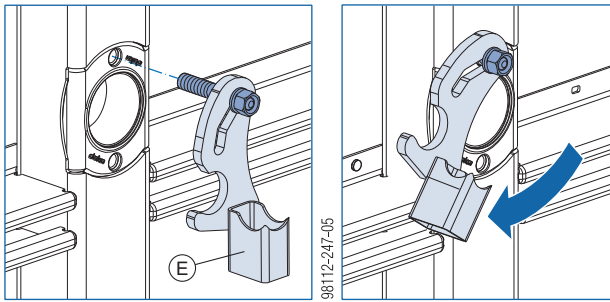

E Framax Xlife plus distance protector NG

- ▶ Screw in the form tie with the Framax Xlife plus ratchet until it is fully engaged and tighten it firmly. Tightening torque: **max. 200 Nm**

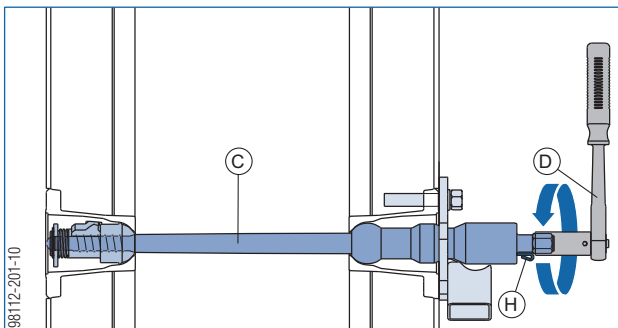

C Framax Xlife plus form tie 20.0

D Framax Xlife plus ratchet 1/2" SW24 L

H Spring clip



Check that the spring clip is installed!

- ▶ Pivot the distance protector over the form tie and tighten the screw (width across flats 24). Tightening torque: **max. 80 Nm**

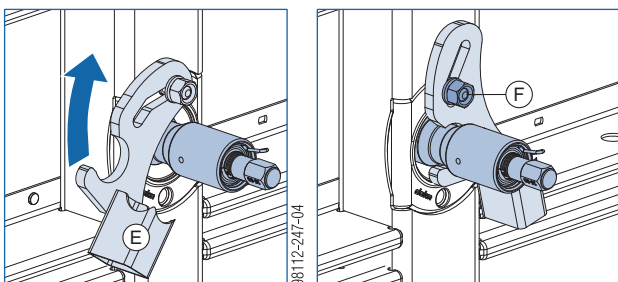

E Framax Xlife plus distance protector NG

F Screw (width across flats 24)

Removing the form ties



Loosening the form ties sooner rather than later after pouring the concrete makes them easier to remove at a later time.

- ▶ Disengage the distance protector (slacken the screw, width across flats 24) and pivot it clear.
- ▶ Unscrew the Framax Xlife plus form tie with the Framax Xlife plus ratchet or an impact wrench.

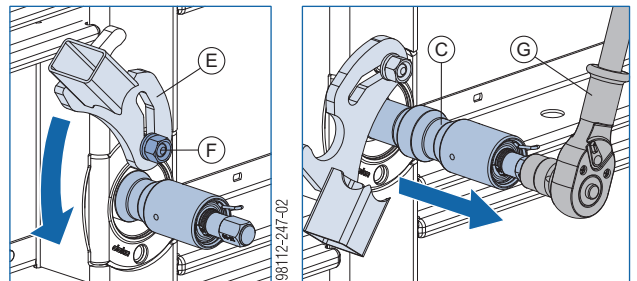

C Framax Xlife plus form tie 20.0

E Framax Xlife plus distance protector NG

F Screw (width across flats 24)

G Framax Xlife plus ratchet 3/4" SW24

- ▶ Temporarily store the Framax Xlife plus form tie in the distance protector.

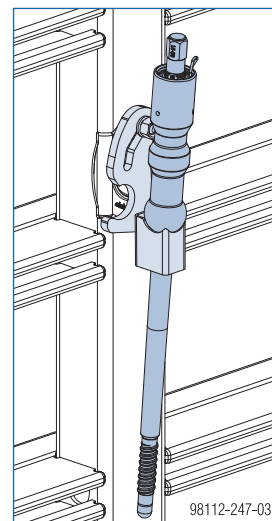

Removing form-tie nut

For example if the panel of the holding formwork is to be used as opposing formwork for the next pouring section.

- ▶ Push the centring disc of the form-tie nut in and at the same time turn it through 180°.

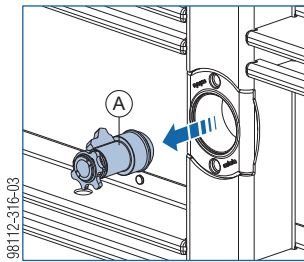

A Framax Xlife plus form-tie nut I 20.0

The form-tie nut can be removed.

- ▶ Insert the parking bolt into the hole in the function profile.

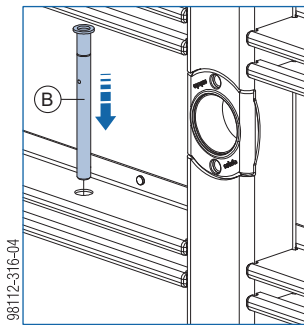

B Framax Xlife plus parking bolt



If the parking bolt is used on its own (without form-tie nut), secure it in the top insertion position with a spring cotter.

- ▶ Push the form-tie nut on to the parking bolt from below and secure it with a spring cotter.

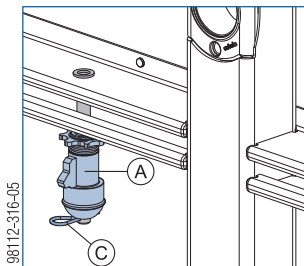

A Framax Xlife plus form-tie nut I 20.0

C Spring cotter 5mm

Cleaning and care of your equipment

- ▶ When cleaning the formwork, always remove any dried concrete residues from the form-tie sleeves of the opposing formwork.

Form-tie points for fair-faced concrete quality

- ▶ Attach the Framax Xlife plus fair-faced concr. cone 87mm (with built-in magnets) to the anchoring sleeves of the panels.
- ▶ On the side of the holding formwork (form-tie nut), seal the fair-faced concrete cone with a sealing disc (self-adhesive).

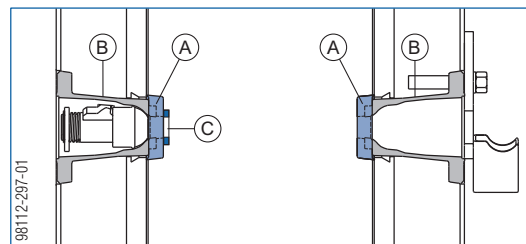

Close-up

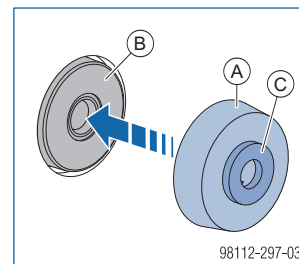

A Framax Xlife plus fair-faced concr. cone 87mm

B Anchoring sleeve inside the Framax Xlife plus panel

C Sealing disc 20/43 20.0/26.5

- ▶ Install the form tie and the distance protector (see the section headed [Tying the panels](#)).

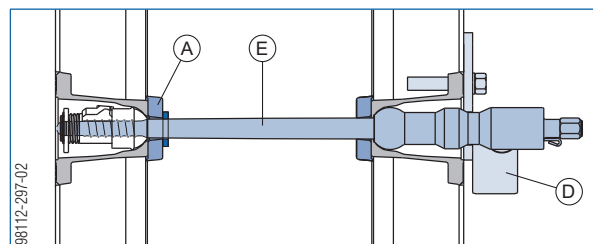

A Framax Xlife plus fair-faced concr. cone 87mm

D Framax Xlife plus distance protector NG

E Framax Xlife plus form tie 20.0

Form-tie points without form tie

In combination with the Screw sleeve 20.0, the Framax Xlife plus fair-faced concrete cone can also be used without a form tie.

This keeps the tie-hole pattern in the fair-faced concrete uniform, even at points where a form tie cannot be inserted (e.g. corner area).

- ▶ Separate the parts of the Screw sleeve 20.0 and shorten threaded part max. 3 mm from collar.

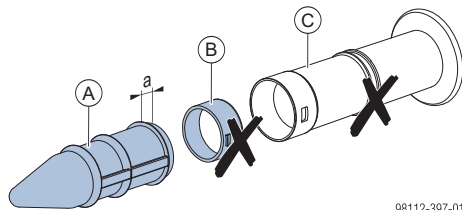

98112-397-01

a ... max. 3 mm

- A** Threaded part of the Screw sleeve 20.0 (shortened)
- B** Off-cut from the threaded part (not used)
- C** Insert part of the Screw sleeve 20.0 (not used)

- ▶ Insert the shortened threaded part of the screw sleeve into the Framax Xlife plus fair-faced concrete cone and slip this on to the anchoring sleeve.
- ▶ From the outside, secure with tie rod and super plate.

Example: Outside corner*

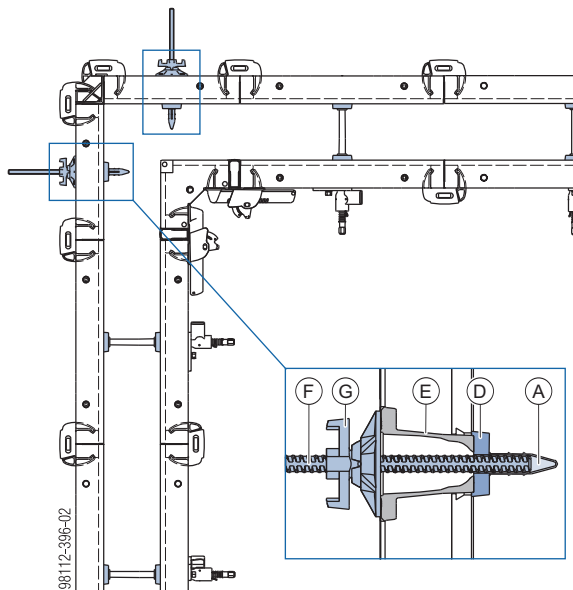

*) see the section headed [90 degree corners](#)

- A** Threaded part of the Screw sleeve 20.0
- D** Framax Xlife plus fair-faced concr. cone 87mm
- E** Anchoring sleeve inside the Framax Xlife plus panel
- F** Tie rod 20.0mm
- G** Super plate 20.0 B

The threaded part of the screw sleeve remains in the concrete.

Variant with the Doka tie rod system 20.0

Note:

For thicker walls and when special requirements apply for the tie point, use the Doka tie rod system 20.0.



For more information on making watertight form-tie points, see the 'Doka form ties for special requirements' User Information booklet.

The **Framax Xlife plus reducer I 20.0** is inserted into the anchoring sleeve in the Framax Xlife plus panel.

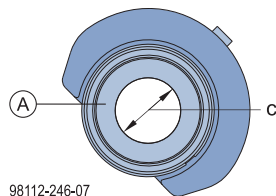
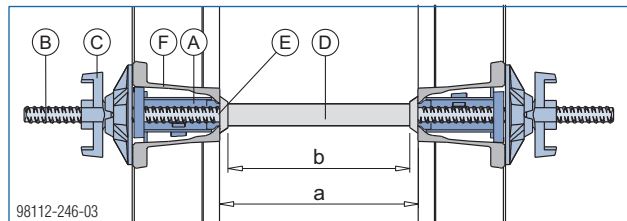

a ... wall thickness

b ... length of the plastic tube = a - 26.0 mm

c ... inside diameter 25.0 mm

A Framax Xlife plus reducer I 20.0

B Tie rod 20.0mm

C Super plate 20.0 B

D Plastic tube 26mm

E Universal cone 26/10mm

F Anchoring sleeve inside the Framax Xlife plus panel

Tie rod 20.0mm:

Permitted load-bearing capacity, allowing a 1.6 : 1 safety factor against failure: 220 kN

Permitted load-bearing capacity to DIN 18216: 160 kN

Exception:

75 kN/m² fresh-concrete pressure with 3.00 m panel height and Tie rod system 20.0

Installation:

- Position the reducer in the anchoring sleeve of the framed formwork panel.

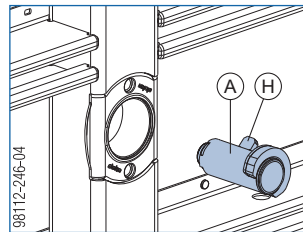

The hook (**H**) of the reducer (**A**) engages in the recess of the anchoring sleeve.

- Turn the lock of the reducer through 180 °. Reducer is locked in position.

Position of the lock:

can be installed and removed

fixed in place

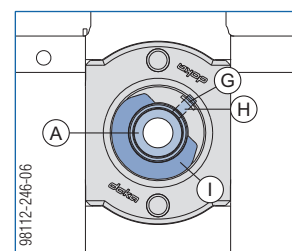
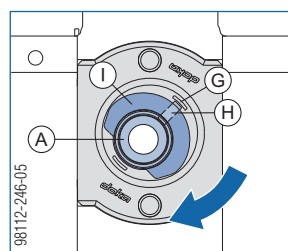

A Framax Xlife plus reducer I 20.0

G Recess

H Hook

I Lock

Variant with the Doka tie rod system 15.0

Note:

When the fresh-concrete pressure is reduced, the Framax Xlife plus reducer makes it possible to use the Tie rod system 15.0.

Exception:

60 kN/m² fresh-concrete pressure acting on whole area, to DIN 18218, observing the surface planeness tolerances to DIN 18202 Table 3 Line 7.

Exception:

55 kN/m² fresh-concrete pressure with 3.00 m panel height and Tie rod system 15.0

Framax head anchor 15-40cm

The Framax head anchor 15-40cm is used for tying Framax Xlife plus panels.

- The Framax head anchor 15-40cm holds the two sides of the formwork the required distance apart.
- For wall thicknesses from 15 to 40 cm.
- Tension bracing and compression bracing.
- Adjustable in a 5-mm grid.
- When using the Framax head anchor 15-40cm, no Framax Xlife plus form ties 20.0 are needed in the following positions:
 - on the top horizontal panel up to a panel width of 0.90m
 - in the top form-tie points of the Framax Xlife plus panel 3.30m (not vertically stacked)



NOTICE

2 Framax head anchors 15-40cm must be mounted for every 2.70m width of gang-form!

Permitted tensile force: 10 kN
Permitted compressive force: 10 kN

Assembly:

- ▶ Position the Framax head anchor 15-40cm directly above the form-tie points of the Framax Xlife plus panel.
- ▶ Telescope the Framax head anchor 15-40cm to the desired length 'a' (= wall thickness) and fix it in the relevant hole with a pin and spring cotter.

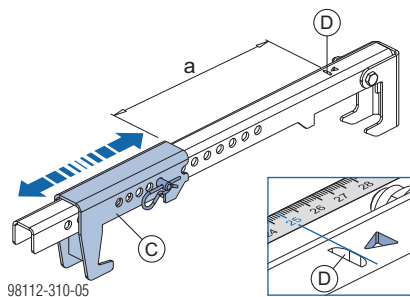

a ... 15 - 40 cm

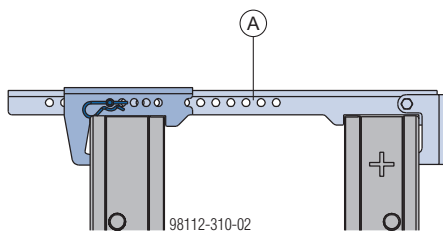

A Framax head anchor 15-40cm

C Adjusting unit

D Notch = measuring point

Example: panel of max. 0.90m vertically stacked

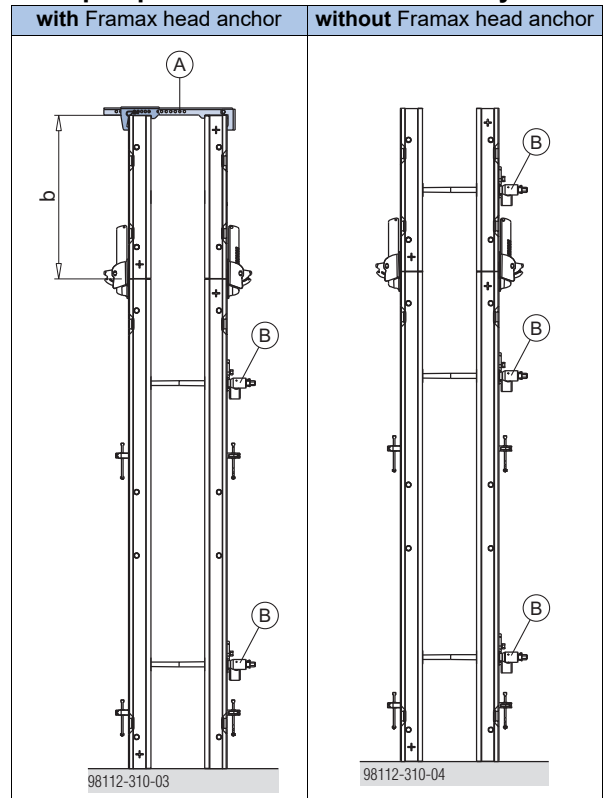

b ... max. 0.90 m

Example: Framax Xlife plus panel 3.30m

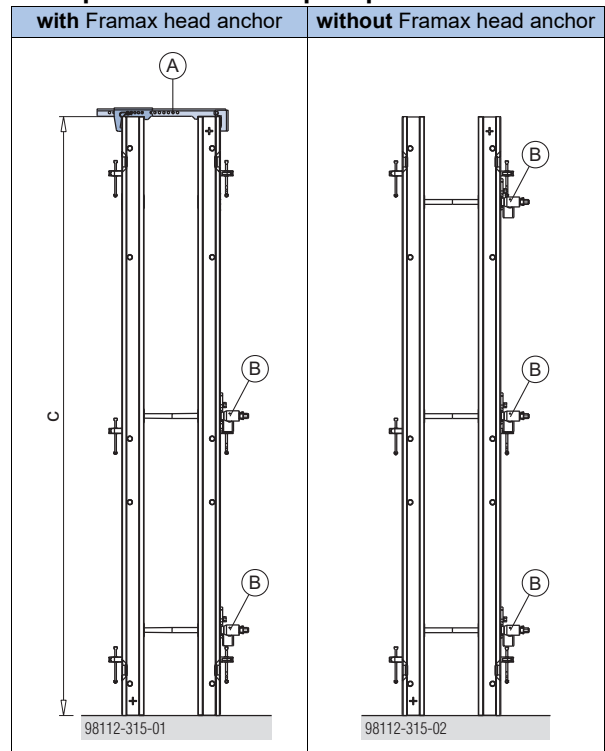









c ... 3.30 m

A Framax head anchor 15-40cm

B Tie rod system Framax Xlife plus 20.0

Closing form-tie holes

Framax Xlife plus plug 38mm	 
Framax Xlife plus plug 24mm	 
Framax Xlife plus concrete cone 28/25 300mm	 
Framax Xlife plus fair-faced concr. plug 87mm	 

 ... fire-resistant

 ... sound-insulating

Framax Xlife plus plug 38mm

Acts as a visible closure.

- Remove concrete burr (e.g. with Countersink concrete D12-35mm).
- Push a Framax Xlife plus plug into the form tie hole at each end.

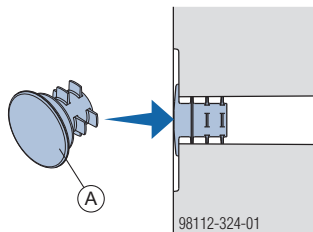

A Framax Xlife plus plug 38mm

Framax Xlife plus plug 24mm

Possibility for sealing concrete surfaces not subject to special requirements (not to be used in fair-faced concrete).

Sealing plug can be filled and smoothed flush.

- Push a Framax Xlife plus plug into the form tie hole at each end.
- Fill the form-tie points with mortar.

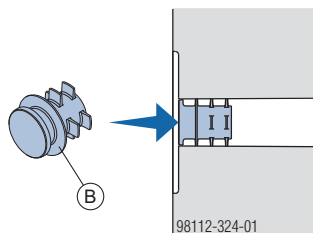

B Framax Xlife plus plug 24mm



Advantage when used as visible closure:
Not possible for third persons to remove the plug without using tools!

Framax Xlife plus concrete cone 28/25 300mm

Concrete cone for closing off form-tie points made using the Framax Xlife plus form tie 20.0 15-30cm.

Note:

On account of tolerances, after installation the concrete cone is not always flush with the concrete surface.

- Protruding: knock off the protruding length
 - Recessed: fill the recess with grout
- Coat the concrete cone with cement slurry or adhesive.
 - Use a hammer to tap the concrete cone into the form-tie hole from the bigger side.

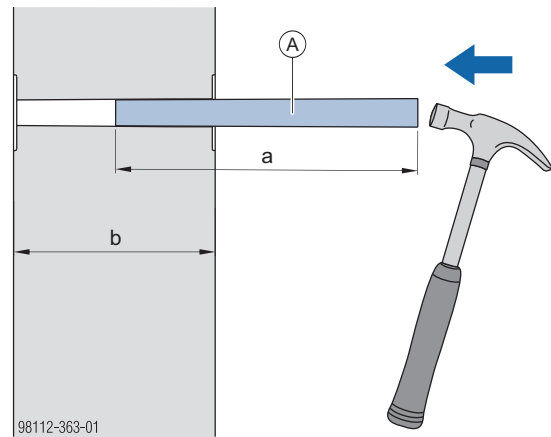

a ... 30 cm
b ... wall thickness (15 to 30 cm)

A Framax Xlife plus concrete cone 28/25 300mm



NOTICE

- Wear protective goggles to protect your eyes when knocking off the protruding length!
- Knock off the protruding end of the concrete with the hammer.

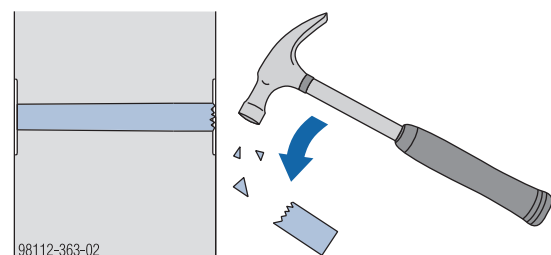

- Grout the form-tie points as necessary.

Framax Xlife plus fair-faced concr. plug 87mm

Acts as closure for form-tie points made with the fair-faced concrete cone 87mm for fair-faced concrete quality.

- Use the Framax Xlife plus cone spanner to remove the Framax Xlife plus fair-faced concr. cone 87mm.

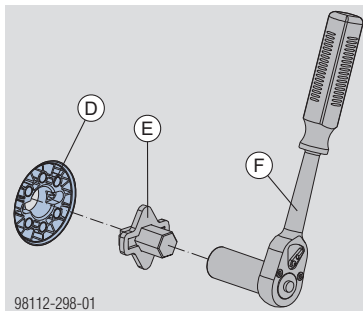

- D Framax Xlife plus fair-faced concr. cone 87mm
- E Framax Xlife plus cone spanner
- F Framax Xlife plus ratchet 1/2" SW24 L

- Close the open form-tie point with a Framax Xlife plus fair-faced concr. plug 87mm.

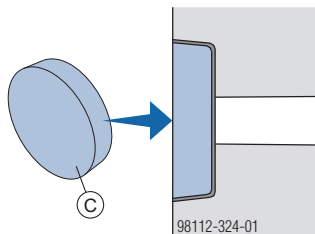

- C Framax Xlife plus fair-faced concr. plug 87mm

The concrete plug is glued into place with standard concrete adhesive.

Sealing form-tie holes

Framax Xlife plus screw plug 25mm			
Framax Xlife plus sealing plug			
Glueing in fibre concrete plugs			
Expanding mortar			

- ... fire-resistant
- ... sound-insulating
- ... watertight (for compatibility with drinking water see the section headed [Drinking-water-compatible seal](#))

Framax Xlife plus screw plug 25mm

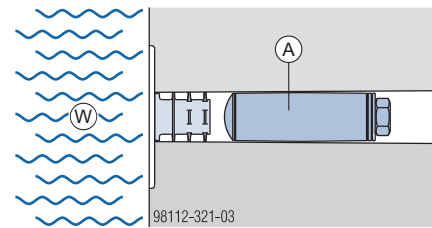

- A Framax Xlife plus screw plug 25mm
- W Water side

NOTICE
 Material temperature of the screw at time of installation at least +10 °C

- Clean the inside of the form-tie hole.
- Position the screw plug in the form-tie hole on the side with the larger opening.



A mark (piece of adhesive tape wrapped round the extension at the appropriate point) on the extension of the torque wrench is useful as a positioning aid.

- If the larger opening is on the water side, first preload the screw plug.
- Use a torque wrench to tighten the screw plug to a **tightening torque of 20 Nm**.
- If applicable, close the form-tie hole with a Framax Xlife plus plug.

Smaller opening on water side

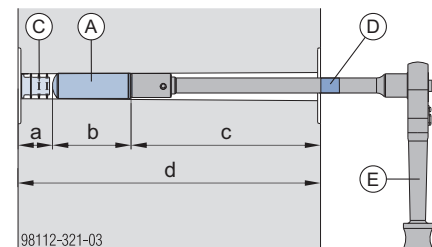

Bigger opening on water side

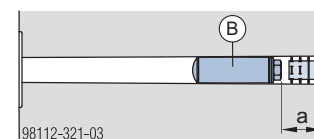

- a ...min. 30 mm on the water side
- b ... 79 mm
- c ... d - a - b
- d ... wall thickness

- A Framax Xlife plus screw plug 25mm
- B Framax Xlife plus screw plug 25mm (preloaded)
- C Plug (optional)
- D Mark (adhesive tape)
- E Torque wrench with extension

Framax Xlife plus sealing plug

Sealing plug can be filled and smoothed flush.

Watertight (2 sealing plugs)

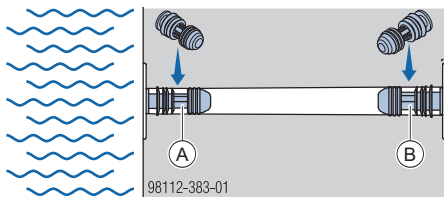

Stormwater-tight (1 sealing plug)

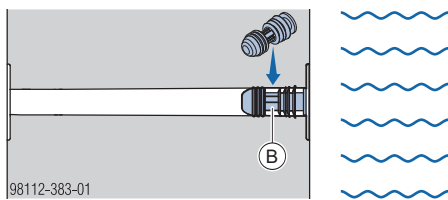
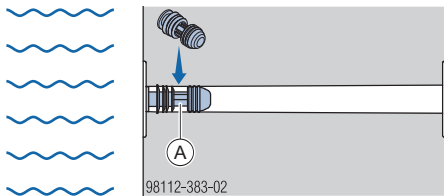

- A Framax Xlife plus sealing plug 25mm (yellow)
- B Framax Xlife plus sealing plug 28mm (blue)

Installation:

- ▶ Clean the inside of the form-tie hole.
- ▶ Use a hammer to tap the sealing plugs flush into the form-tie hole (smaller opening: yellow sealing plug, larger opening: blue sealing plug).

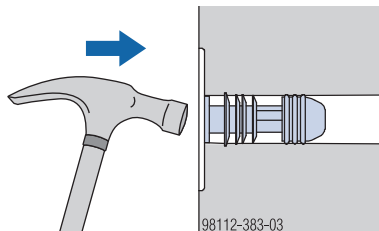

If necessary, use a tie rod to tap the sealing plug farther into the hole.

- ▶ Grout the form-tie points.

Glueing in fibre concrete plugs

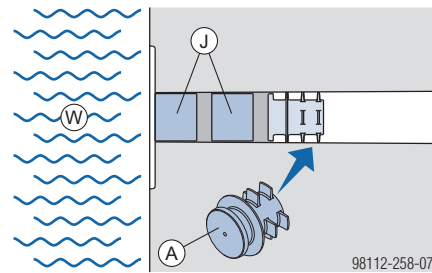

- A Framax Xlife plus plug 24mm with hole
- J Fibre concrete plug D24 21mm
- W Water side

Note:

Use **Framax Xlife plus plugs 24mm with hole**! Air escapes through the hole in the plug as the adhesive is compressed.

- ▶ Clean the inside of the form-tie hole.
- ▶ Use a tie rod to push the Framax Xlife plus plug 24mm with hole approximately 6 cm into the form-tie hole.
- ▶ From the plug, fill the form-tie hole approx. 3 cm deep with epoxy-resin adhesive.
- ▶ Push the first fibre concrete plug into the adhesive and compress the adhesive.

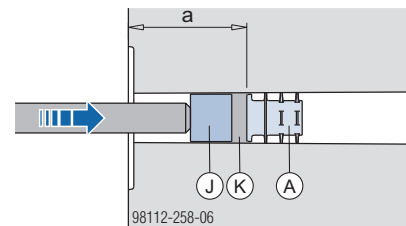

a ... approx. 6 cm

- A Framax Xlife plus plug 24mm with hole
- J Fibre concrete plug D24 21mm
- K Epoxy-resin adhesive

- ▶ Inject enough epoxy-resin adhesive to fill the form-tie hole of the fibre concrete plug to 5 mm below the surface of the concrete.
- ▶ Push the second fibre concrete plug into the adhesive and compress the adhesive.
- ▶ Use a spatula to remove the excess adhesive.

Product recommendation

Mapefix EP epoxy-resin adhesive

- Epoxy-resin-based 2-component adhesive for structural loads.
- The surface must be free of dust and oil.
- Application temperature: min. +5 °C



98112-500-01



Read and observe the manufacturer's technical data sheet!

KarPox adhesive

- Epoxy-resin-based 2-component adhesive for structural loads.
- The surface must be free of dust and oil.
- Application temperature: min. +5 °C

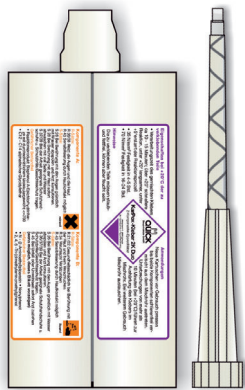

98112-500-03

KarPox double cartridge 2K Duo 2x310ml



Read and observe the manufacturer's technical data sheet!

Expanding mortar

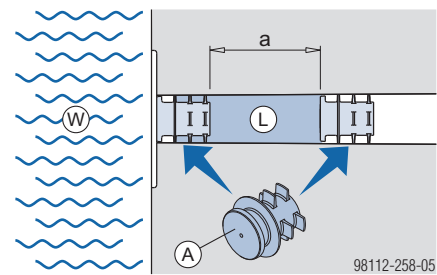

98112-258-05

a ... min. 5 cm

A Framax Xlife plus plug 24mm with hole

L Expanding mortar EM 0-0.4 E1 25kg

W Water side

Note:

Use **Framax Xlife plus plugs 24mm with hole!** Air escapes through the hole in the plug as the adhesive is compressed.

- Clean the inside of the form-tie hole.
- Use a tie rod to push the Framax Xlife plus plug 24mm with hole at least 8 cm into the form-tie hole.

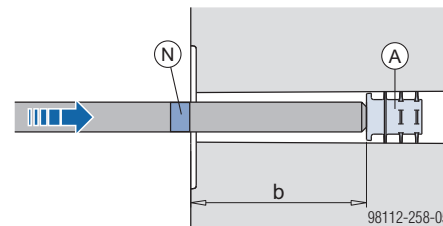

98112-258-05

b ... min. 8 cm

A Framax Xlife plus plug 24mm with hole

N Mark (adhesive tape)

- Inject enough expanding mortar to fill the form-tie hole of the plug to 5 mm below the surface of the concrete.

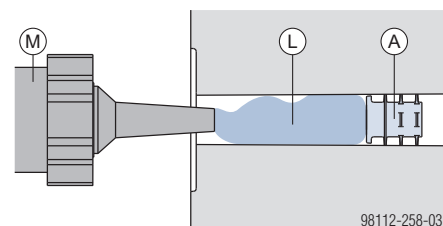

98112-258-03

A Framax Xlife plus plug 24mm with hole

L Expanding mortar EM 0-0.4 E1 25kg

M Backfilling syringe

- Press the second Framax Xlife plus plug 24mm with hole into the form-tie hole until expanding mortar is squeezed out of the hole in the plug. Expanding mortar is compacted (thickness in compacted state min. 5 cm).

Drinking-water-compatible seal

Smooth an epoxy-resin adhesive with approval for drinking-water applications over the **sealed form-tie hole** *) to obtain a surface that is drinking-water-compatible (drinking-water tanks, for example).



*) usable in all sealing situations shown here

Example, Framax Xlife plus screw plug 25mm:

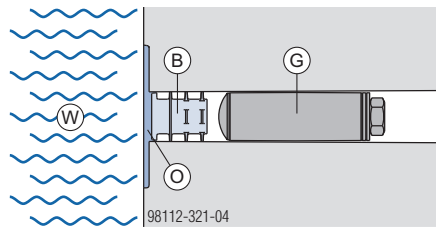

B Framax Xlife plus plug 24mm

G Framax Xlife plus screw plug 25mm

O Epoxy-resin adhesive with approval for drinking-water applications

W Water side (drinking water)

- ▶ On the water-wetted side, install the plug recessed at least 3 mm.
- ▶ Smooth the adhesive flush with the surface.

Length adjustment using closures

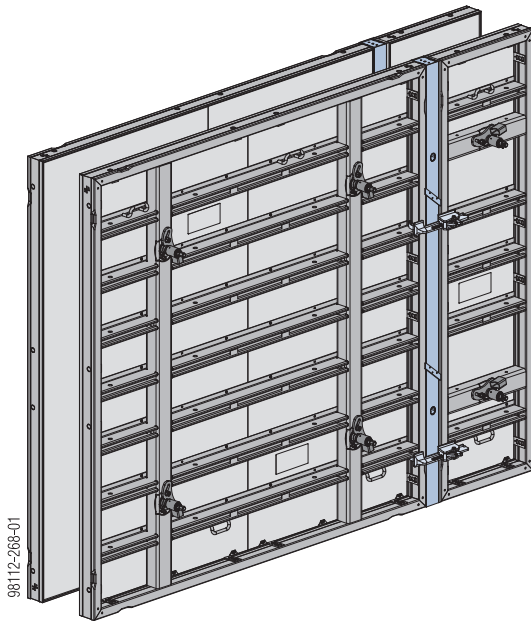

By combining the **Framax aluminium closures** (5 and 10 cm) and the **Framax fitting timbers** (2, 3, 5 and 10 cm) in various ways, closures can be made in 1 cm increments.

Example:

- Closure width = 12 cm
 - 1 Framax aluminium closure 10cm
 - 1 Framax fitting timber 2cm

Closures: 0 - 15 cm

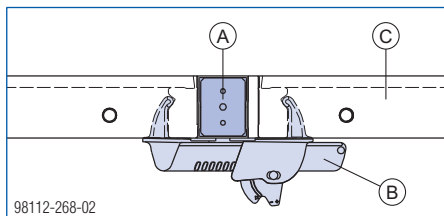

- A** Framax aluminium closure or Framax Xlife plus aluminium closure 3.00m / Framax fitting timber
- B** Framax multi function clamp
- C** Framax Xlife plus panel

Closures: 0 - 20 cm

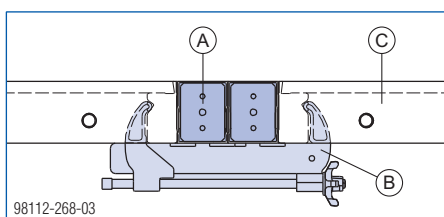

- A** Framax aluminium closure or Framax Xlife plus aluminium closure 3.00m / Framax fitting timber
- B** Framax adjustable clamp
- C** Framax Xlife plus panel

Note:

Fit the Framax adjustable clamp in the same position as the Framax multi function clamp

Framax adjustable clamp:
Permitted tensile force: 10.0 kN

Closures: 17 - 35 cm

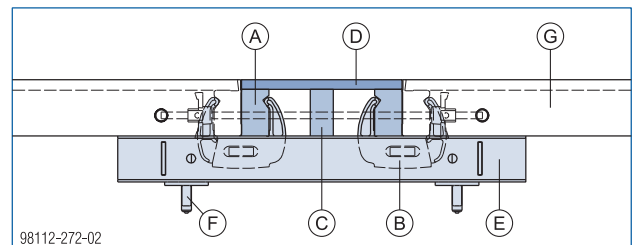
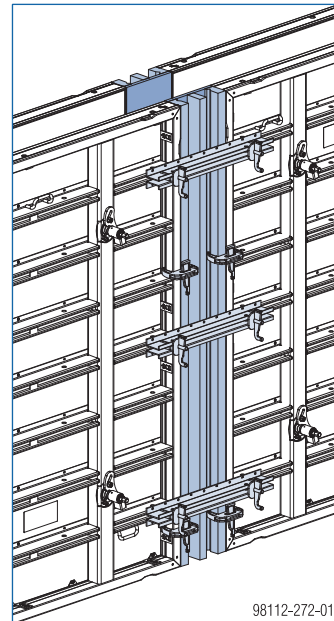

- A** Framax moulded timber 27mm (for 27mm formwork sheet) or Framax moulded timber 21mm (for 21mm formwork sheet) or Framax moulded timber 18mm (for 18mm formwork sheet)
- B** Framax quick acting clamp RU
- C** Squared timber
- D** Formwork sheet
- E** Framax universal waling
- F** Framax wedge clamp
- G** Framax Xlife plus panel
(no 1.35m wide panel or 3.00m panel on its side!)

Note:

A tension anchor can be made using a tie rod and Star grip nut 15.0 G.

Closure with non-tied closure panels

A non-tied closure can be made between two panels with a width of 2.70 m using closure panels.

Note:

- The closure panel does not need to be tied.
- **2 additional clamps** are needed at each inter-panel joint to the closure panel.
- The max. width of the closure panel depends on the panel height and must not be exceeded.

Pour height 2.70m

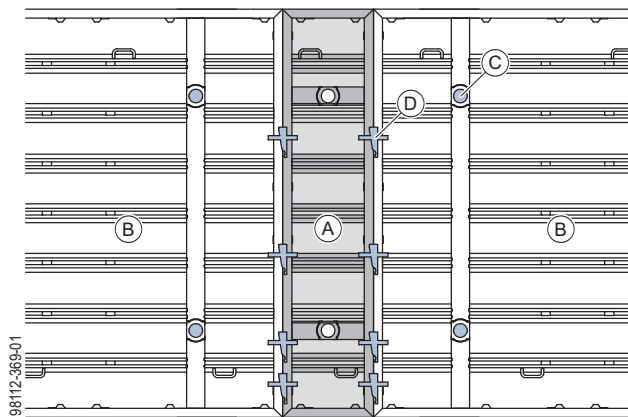

A Framax Xlife plus panel (max. width of 0.60m)

B Framax Xlife plus panel 2.70x2.70m

C Framax Xlife plus form tie 20.0

D Framax quick acting clamp RU

Pour height 3.00m

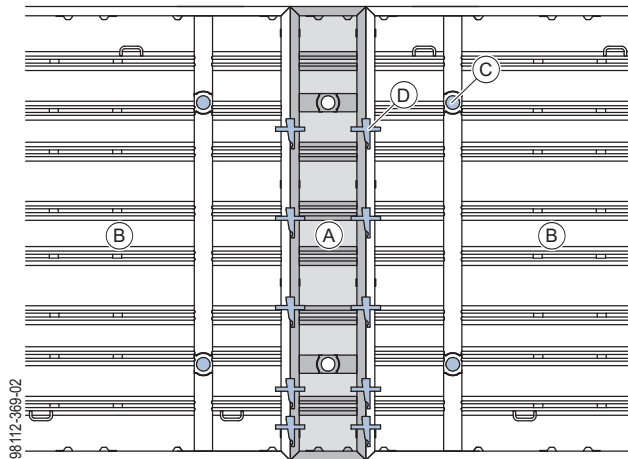

A Framax Xlife plus panel (max. width of 0.50m)

B Framax Xlife plus panel 2.70x3.00m

C Framax Xlife plus form tie 20.0

D Framax quick acting clamp RU

Pour height 3.30m

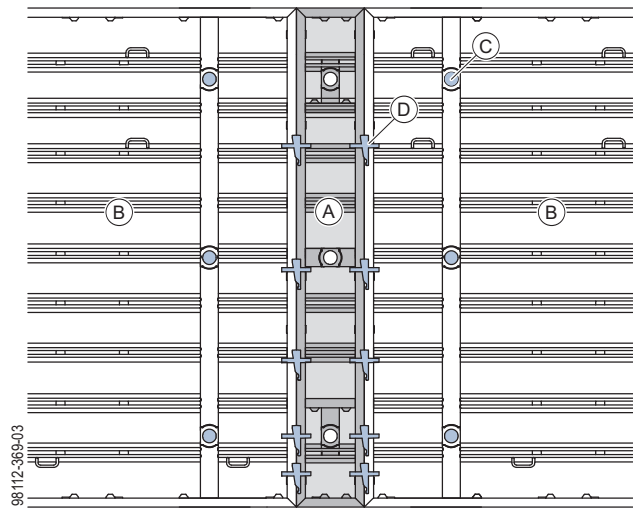

A Framax Xlife plus panel (max. width of 0.45m)

B Framax Xlife plus panel 2.70x3.30m

C Framax Xlife plus form tie 20.0

D Framax quick acting clamp RU

90 degree corners

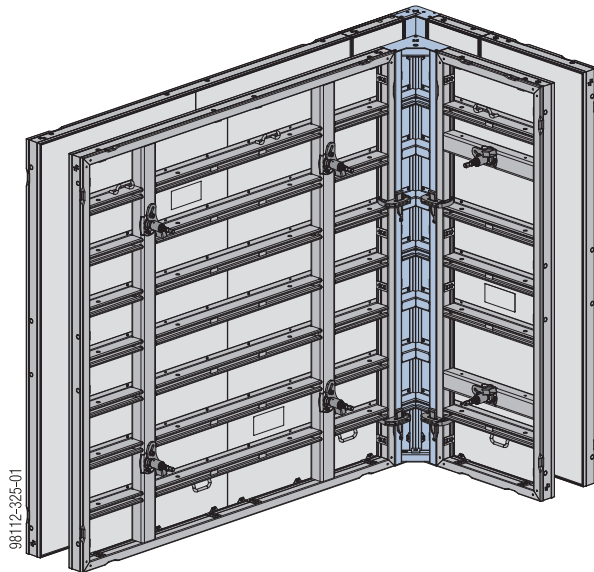

Note:

Seal off any unneeded anchoring sleeves with the **Framax Xlife plus frame hole plug 32mm NG**.

Inside formwork

Framax Xlife plus inside corner 30/30cm

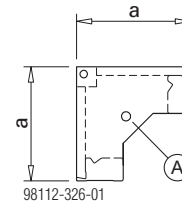

a ... 30 cm

The hole drilled in the inside corner enables a vertical stacking connection to be made using universal fixing bolts + super plates.

- A** Framax Xlife plus inside corner 30/30cm or
Framax Xlife inside corner

Outside formwork

Right-angled outside corners can be formed in any of the following ways:

- Framax outside corner (A)
- Framax Xlife plus outs. corner 10/10cm (B)
- Framax Xlife universal panel (C)

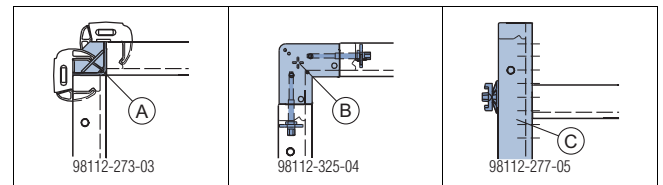

Note:

For details regarding extra inter-panel connections on outside corners (for increased tensile loads) see the section headed [Inter-panel connections for increased tensile loads](#).

Framax outside corner

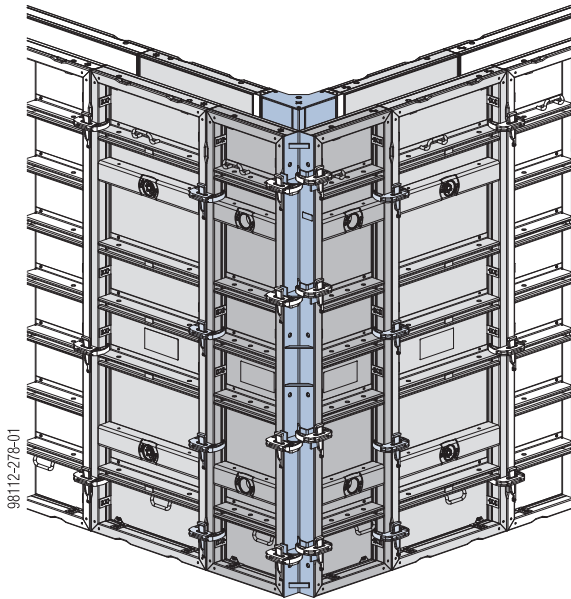

98112-278-01

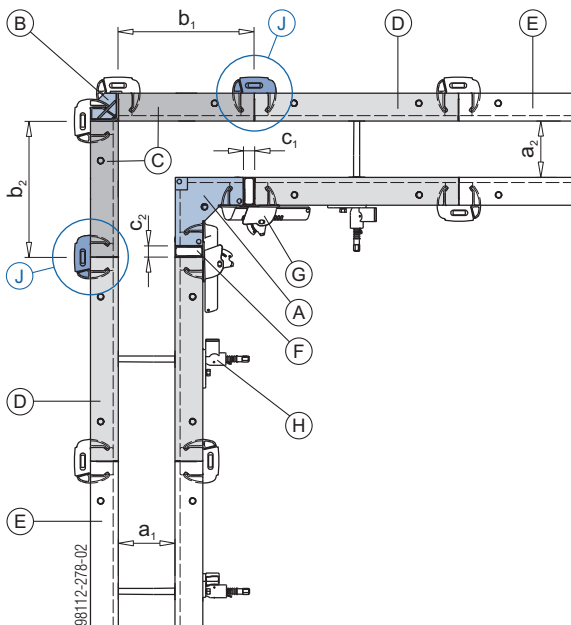

98112-278-02

a_{1,2} ... wall thickness
b_{1,2} ... panel width
c_{1,2} ... closure width

- A** Framax Xlife plus inside corner 30/30cm or Framax Xlife inside corner
- B** Framax outside corner
- C** Framax Xlife plus panel 0.45 - 0.75m
- D** Framax Xlife plus panel (no 1.35m wide panel or 3.00m panel on its side!)
- E** Framax Xlife plus panel
- F** Closure 0 - 15 cm (Framax aluminium closure / Framax fitting timber)
- G** Framax multi function clamp
- H** Tie rod system Framax Xlife plus 20.0
- J** Inter-panel connections (see section [Inter-panel connection, corner gangform \(outside\) with adjoining Framax Xlife plus panel](#))

Width of the Framax Xlife plus panel in the outside corner

Wall thickness (a)	Panel width (b)
15 cm	0.45m (45 cm)
>15 - 20 cm	0.50m (50 cm)
>20 - 25 cm	0.55m (55 cm)
>25 - 30 cm	0.60m (60 cm)
>30 - 40 cm	0.75m (75 cm)

Closure width in the inside corner

Closure width **c** = panel width **b** [cm] - 30 cm - wall thickness **a** [cm]

Example:

- Wall thickness = 35 cm
=> Panel width (b) = **0.75m (75 cm)**

Closure width = 75 cm - 30 cm - 35 cm = **10 cm**



When there is a **closure on both sides** of the inside corner, bracing can be achieved economically with the **universal corner waling**.

Inter-panel connections

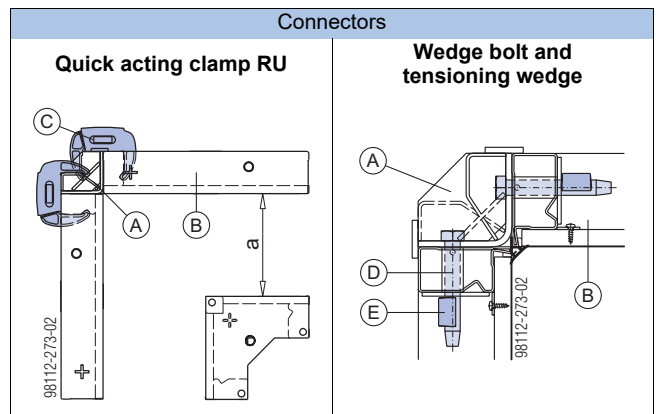

a ... wall thickness

- A** Framax outside corner
- B** Framax Xlife plus panel
- C** Quick acting clamp RU
- D** Framax wedge bolt RA 7.5
- E** Framax tensioning wedge R

Required number of connectors:

Wall thickness	Height of outside corner	Quick acting clamp RU	Tensioning wedge + wedge bolt
up to 30 cm	0.60m	2	—
	1.35m	4	—
	2.70m	8	—
	3.00m	10	—
	3.30m	10	—
> 30 and up to 40 cm	0.60m	2	2
	1.35m	—	4
	2.70m	—	8
	3.00m	—	8
	3.30m	—	10



NOTICE

Do not oil or grease wedged connections.



When striking the formwork, separate the gang-form at the Framax outside corner (remove the connectors on one side of the Framax outside corner).

Framax Xlife plus outs. corner 10/10cm

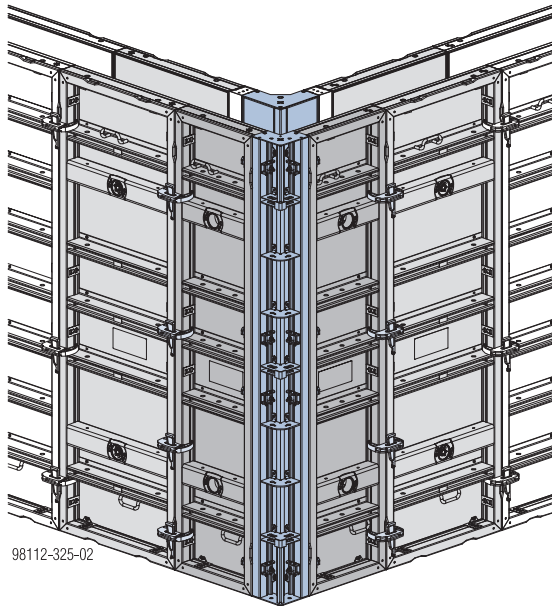

98112-325-02

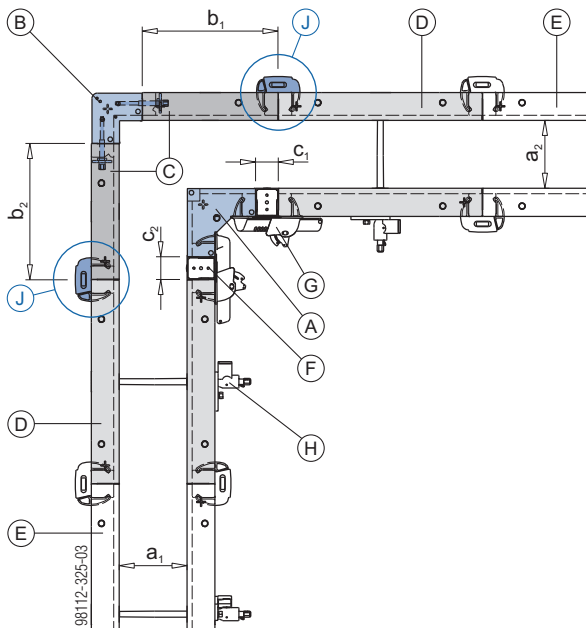

a_{1,2} ... wall thickness
b_{1,2} ... panel width
c_{1,2} ... closure width

- A** Framax Xlife plus inside corner 30/30cm or Framax Xlife inside corner
- B** Framax Xlife plus outs. corner 10/10cm
- C** Framax Xlife plus panel **0.45 - 0.75m**
- D** Framax Xlife plus panel (no 1.35m wide panel or 3.00m panel on its side!)
- E** Framax Xlife plus panel
- F** Closure **0 - 15 cm** (Framax aluminium closure / Framax fitting timber)
- G** Framax multi function clamp
- H** Tie rod system Framax Xlife plus 20.0
- J** Inter-panel connections (see the section headed [Inter-panel connection, corner gangform \(outside\) with adjoining Framax Xlife plus panel](#))

Width of the Framax Xlife plus panel in the outside corner

Wall thickness (a)	Panel width (b)
15 - 25 cm	0.45m (45 cm)
>25 - 30 cm	0.50m (50 cm)
>30 - 35 cm	0.55m (55 cm)
>35 - 40 cm	0.60m (60 cm)

Closure width in the inside corner

Closure width **c** = panel width **b** [cm] - 20 cm - wall thickness **a** [cm]

Example:

- Wall thickness = 35 cm
=> Panel width (b) = **0.60m (60 cm)**

Closure width = 60 cm - 20 cm - 35 cm = **5 cm**



When there is a **closure on both sides** of the inside corner, bracing can be achieved economically with the **universal corner waling**.

Inter-panel connections

Clamping bolt 15.0 in parking position:

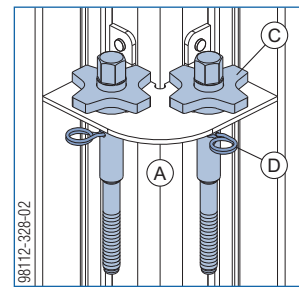

Clamping bolt 15.0 installed:

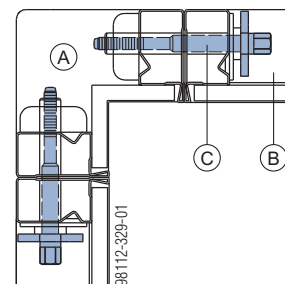

- A** Framax Xlife plus outs. corner 10/10cm
- B** Framax Xlife plus panel
- C** Clamping bolt 15.0
- D** Spring cotter D3 with double eye

Number of connectors:

One clamping bolt 15.0 must be screwed into each cross hole of the outside corner.

Clamping bolt 15.0:

Permissible tensile force: 25.0 kN
Permissible shear force: 25.0 kN

Assembly

The outside corner is assembled on the flat, at ground level.

- Lay the Framax Xlife plus panel and the Framax Xlife plus outside corner 10/10cm on squared timbers 10/10cm.

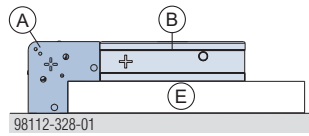

- A Framax Xlife plus outs. corner 10/10cm
- B Framax Xlife plus panel
- E Squared timber 10/10cm

- Remove the clamping bolts from the parking position, insert them from the panel side and screw them into the cross holes.

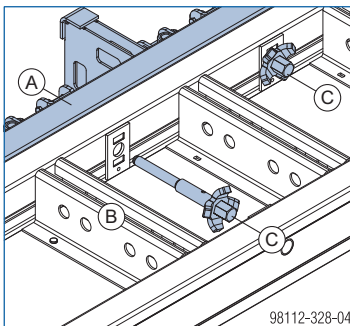

- A Framax Xlife plus outs. corner 10/10cm
- B Framax Xlife plus panel
- C Clamping bolt 15.0

Tighten the clamping bolt with the Framax Xlife plus ratchet.



- Install the bottom clamping bolt and provisionally secure the outside corner to the panel with 2 quick acting clamps RU.

This makes the rest of the clamping bolts easier to install.

- Turn the gang-form over (180°), position the second squared timber (necessary for detaching the Framax lifting hook) and set down the gang-form.
- Crane lift the second Framax Xlife plus panel onto the outside corner.

- Join this panel to the outside corner in the same way.

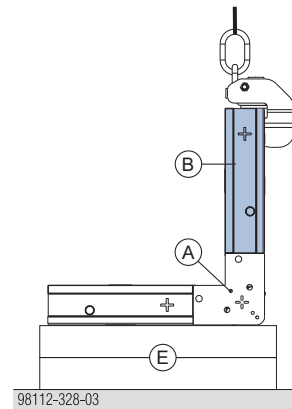

- A Framax Xlife plus outs. corner 10/10cm
- B Framax Xlife plus panel
- E Squared timber 10/10 cm + squared timber 10/10 cm

Lifting by crane

Vertical repositioning of the Framax Xlife plus outside corner:

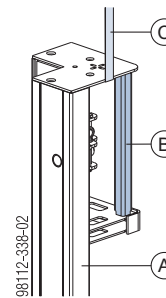

- A Framax Xlife plus outs. corner 10/10cm
- B Shaped tube
- C Textile strap (site-provided)

Repositioning the corner gang-form:

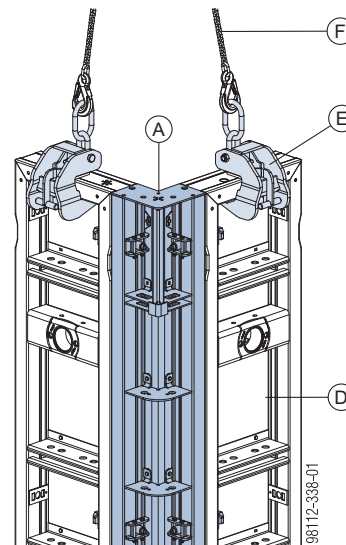

- A Framax Xlife plus outs. corner 10/10cm
- D Framax Xlife plus panel
- E Framax lifting hook
- F Two-part lifting chain



Follow the directions in the 'Framax lifting hook' Operating Instructions!

Framax Xlife universal panel

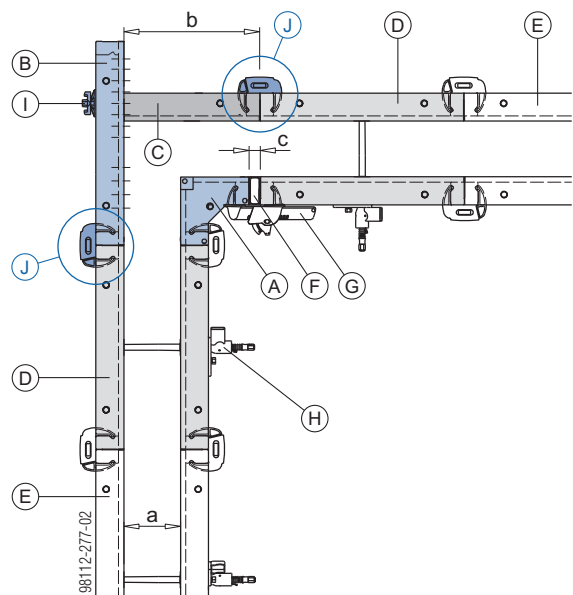
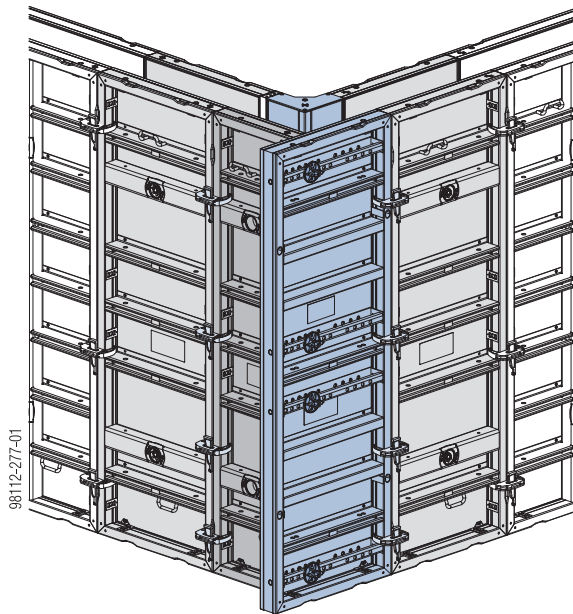

a_{1,2} ... wall thickness
b_{1,2} ... panel width
c_{1,2} ... closure width

- A** Framax Xlife plus inside corner 30/30cm or Framax Xlife inside corner
- B** Framax Xlife universal panel 0.90m
- C** Framax Xlife plus panel **0.45 - 0.75m**
- D** Framax Xlife plus panel
(no 1.35m wide panel or 3.00m panel on its side!)
- E** Framax Xlife plus panel
- F** Closure **0 - 15 cm** (Framax aluminium closure / Framax fitting timber)
- G** Framax multi function clamp
- H** Tie rod system Framax Xlife plus 20.0
- I** Framax universal fixing bolt + Super plate 15.0
- J** Inter-panel connections (see section [Inter-panel connection, corner gangform \(outside\) with adjoining Framax Xlife plus panel](#))

Note:

Different wall-thickness grids (5 and 6 cm) are possible by installing the 0.90 m wide universal panel upside down.

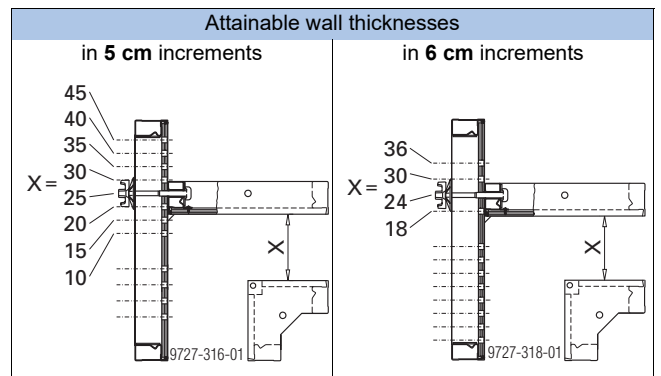

If the **entire outside corner** is raised and repositioned by crane, then **no universal walings** are needed for height-bracing the panels.

Note:

Seal off the unused holes in the formwork sheet of the universal panels with **Framax plugs R 24.5**.

Width of the Framax Xlife plus panel in the outside corner

Wall thickness (a)	Panel width (b)
15 cm	0.45m (45 cm)
>15 - 20 cm	0.50m (50 cm)
>20 - 25 cm	0.55m (55 cm)
>25 - 30 cm	0.60m (60 cm)
>30 - 40 cm	0.75m (75 cm)

Closure width in the inside corner

Closure width **c** =
panel width **b** [cm] - 30 cm - wall thickness **a** [cm]

Example:

- Wall thickness = 35 cm
=> Panel width (b) = **0.75m (75 cm)**

Closure width = 75 cm - 30 cm - 35 cm = **10 cm**



When there is a **closure on both sides** of the inside corner, bracing can be achieved economically with the **universal corner waling**.

Inter-panel connections

Required numbers of universal fixing bolts + Super plates 15.0:

Framax Xlife universal panel 1.35m	2
Framax Xlife universal panel 2.70m	4
Framax Xlife plus universal panel 3.00m	4
Framax Xlife universal panel 3.30m	5

Inter-panel connection, corner gangform (outside) with adjoining Framax Xlife plus panel

Wall thickness from 15 to 30 cm

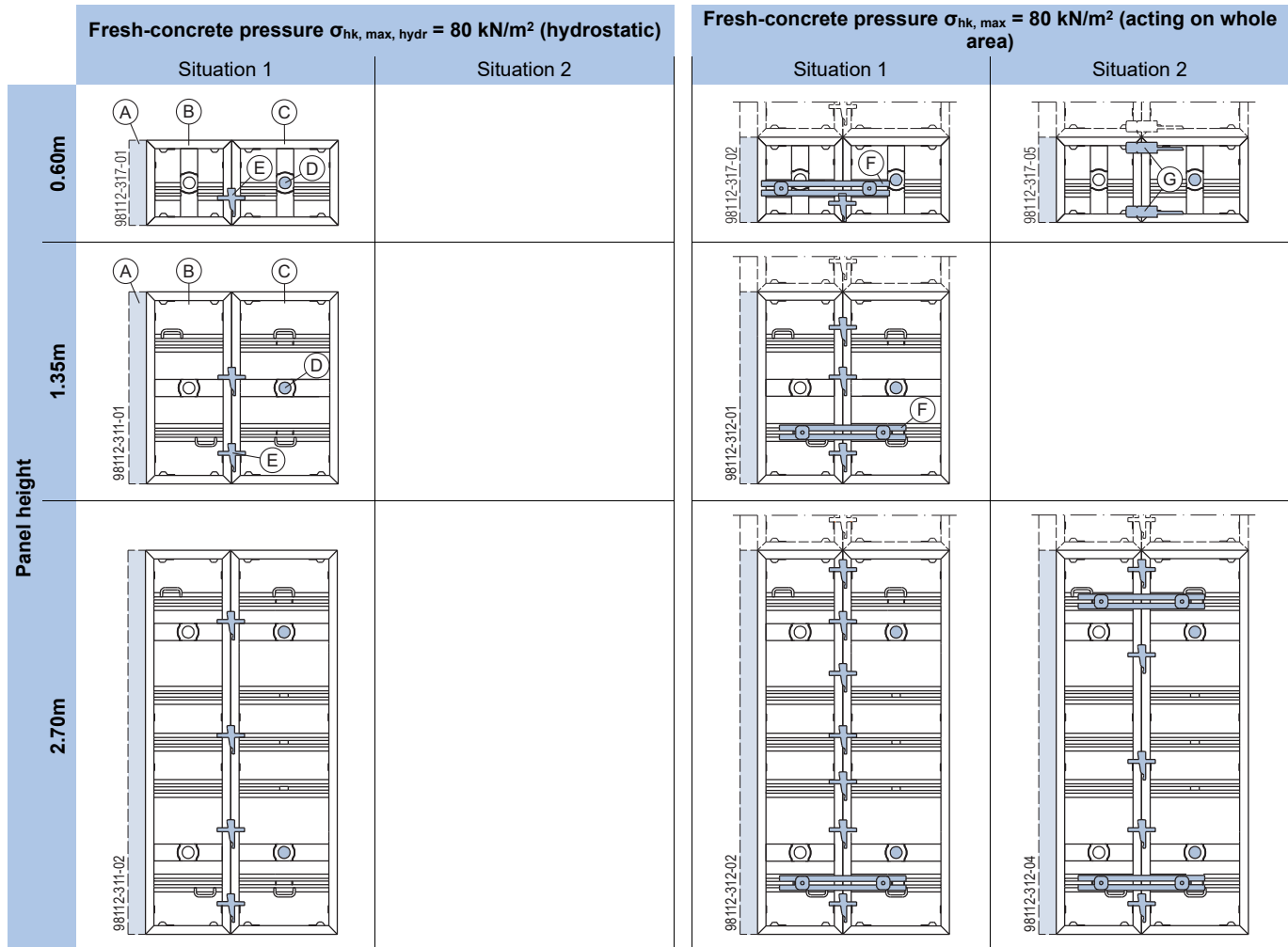

- A** Outside corner (Framax Xlife plus outs. corner 10/10cm / Framax outside corner / Framax Xlife universal panel); Inter-panel connection, see the section on the outside corner used
- B** Framax Xlife plus panel 0.45m - 0.60m
- C** Framax Xlife plus panel
(no 1.35m wide panel or 3.00m panel on its side!)
- D** Framax Xlife plus form tie 20.0
- E** Framax quick acting clamp RU
(or Framax multi function clamp for a closure)
- F** Framax universal waling + 2 Framax wedge clamps
- G** Framax multi function clamp

Alternative with Quick acting clamp RU and universal fixing bolt (fresh-concrete pressure acting on whole area)

Panel height	Quick acting clamp RU	Universal fixing bolt + Star grip nut 15.0 G
0.60 m	1	1
1.35 m	2	2
2.70 m	4	3

Wall thickness from 15 to 30 cm

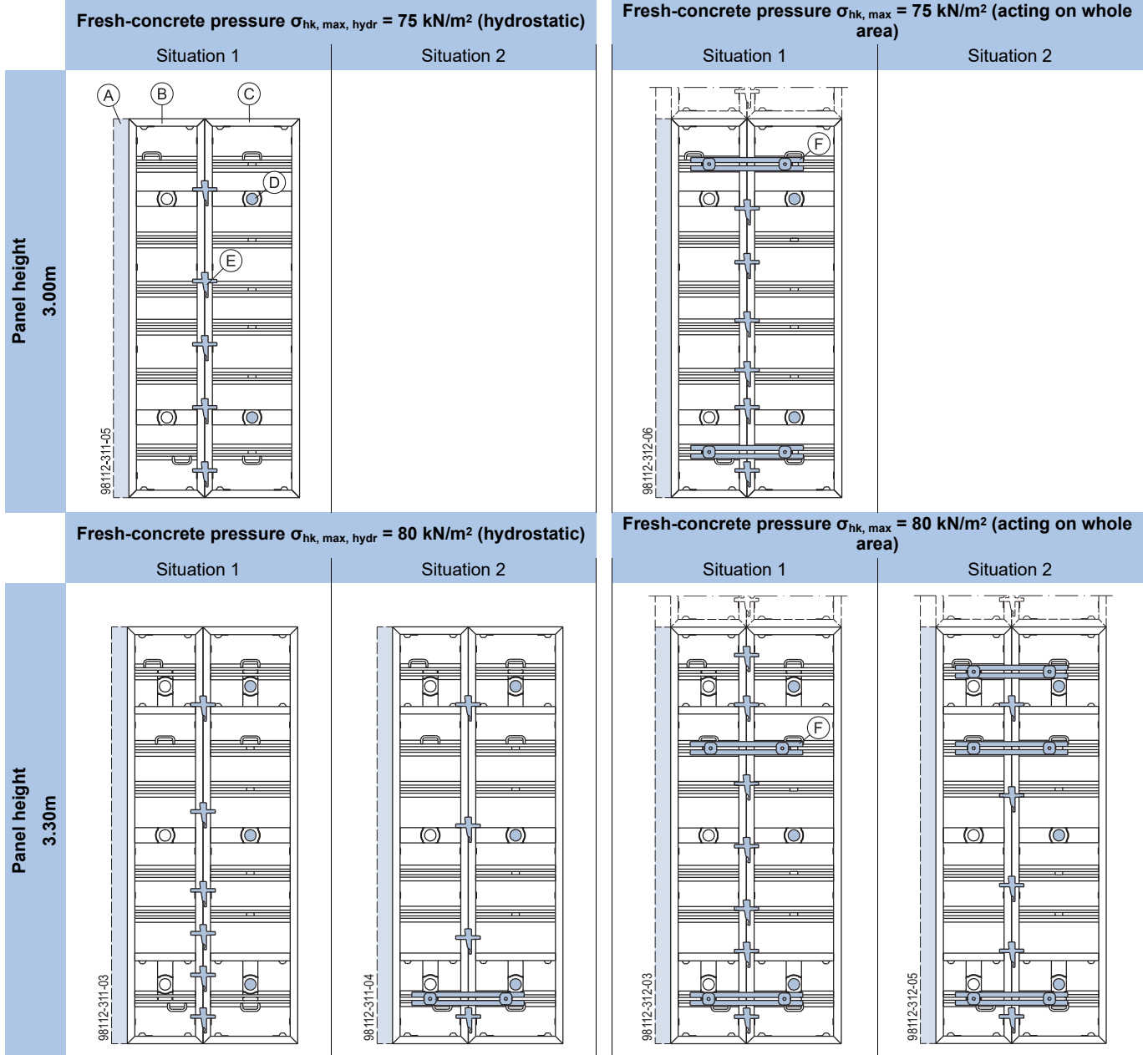

- A Outside corner (Framax Xlife plus outs. corner 10/10cm / Framax outside corner / Framax Xlife universal panel); Inter-panel connection, see the section on the outside corner used
- B Framax Xlife plus panel 0.45m - 0.60m
- C Framax Xlife plus panel (no 1.35m wide panel or 3.00m panel on its side!)
- D Framax Xlife plus form tie 20.0
- E Framax quick acting clamp RU (or Framax multi function clamp for a closure)
- F Framax universal waling + 2 Framax wedge clamps

Alternative with Quick acting clamp RU and universal fixing bolt (fresh-concrete pressure acting on whole area)

Panel height	Quick acting clamp RU	Universal fixing bolt + Star grip nut 15.0 G
3.00 m *)	4	3
3.30 m	4	4

*) Fresh-concrete pressure max. 75kN/m²

Wall thickness >30 and up to 40 cm

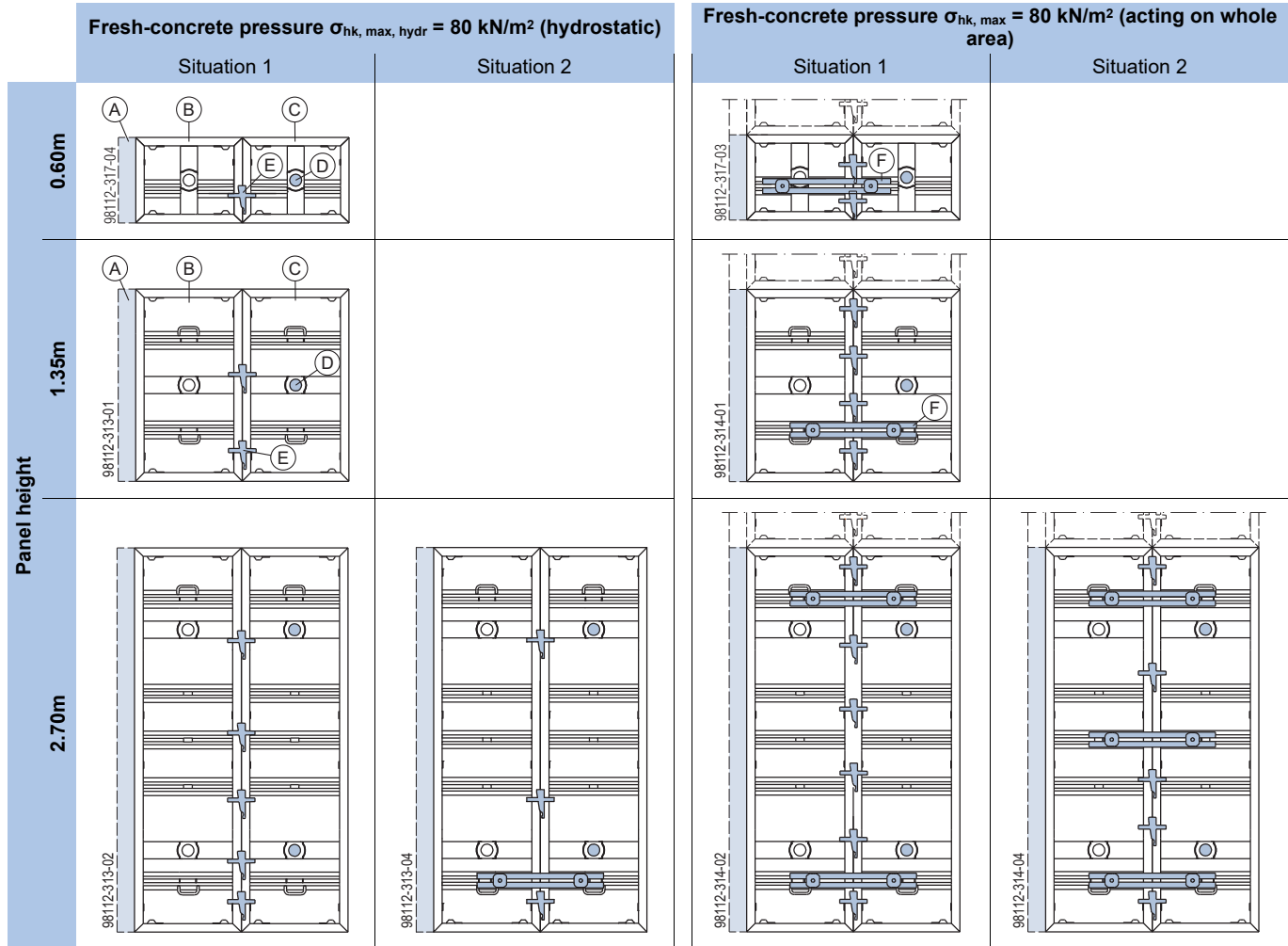

- A Outside corner (Framax Xlife plus outs. corner 10/10cm / Framax outside corner / Framax Xlife universal panel); Inter-panel connection, see the section on the outside corner used
- B Framax Xlife plus panel **0.75m** (with Framax Xlife plus outs. corner 10/10cm: **0.60m**)
- C Framax Xlife plus panel (no 1.35m wide panel or 3.00m panel on its side!)
- D Framax Xlife plus form tie 20.0
- E Framax quick acting clamp RU (or Framax multi function clamp for a closure)
- F Framax universal waling + 2 Framax wedge clamps

Alternative with Quick acting clamp RU and universal fixing bolt (fresh-concrete pressure acting on whole area)

Panel height	Quick acting clamp RU	Universal fixing bolt + Star grip nut 15.0 G
0.60 m	1	1
1.35 m	3	2
2.70 m	5	3

Wall thickness >30 and up to 40 cm

Fresh-concrete pressure $\sigma_{hk, max, hydr} = 75 \text{ kN/m}^2$ (hydrostatic)

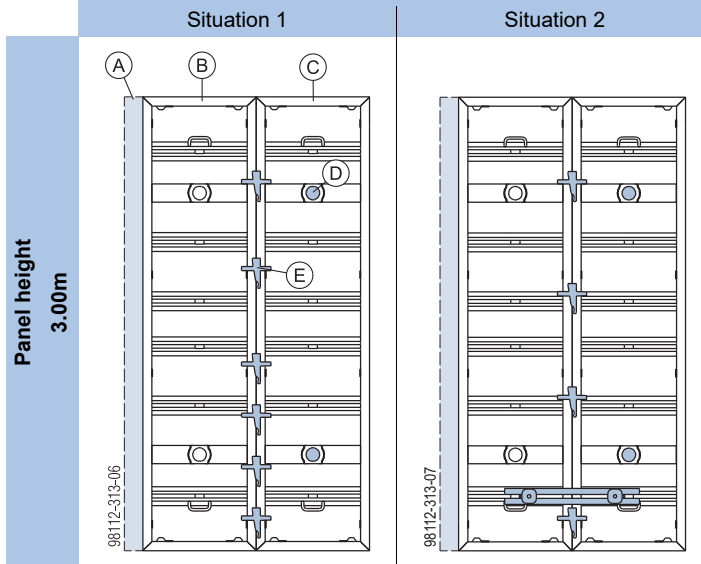

Fresh-concrete pressure $\sigma_{hk, max} = 75 \text{ kN/m}^2$ (acting on whole area)

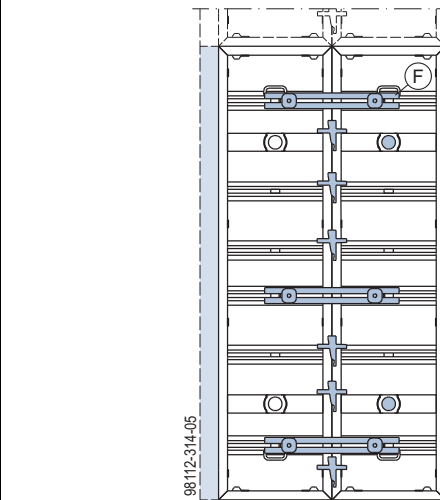

Fresh-concrete pressure $\sigma_{hk, max, hydr} = 80 \text{ kN/m}^2$ (hydrostatic)

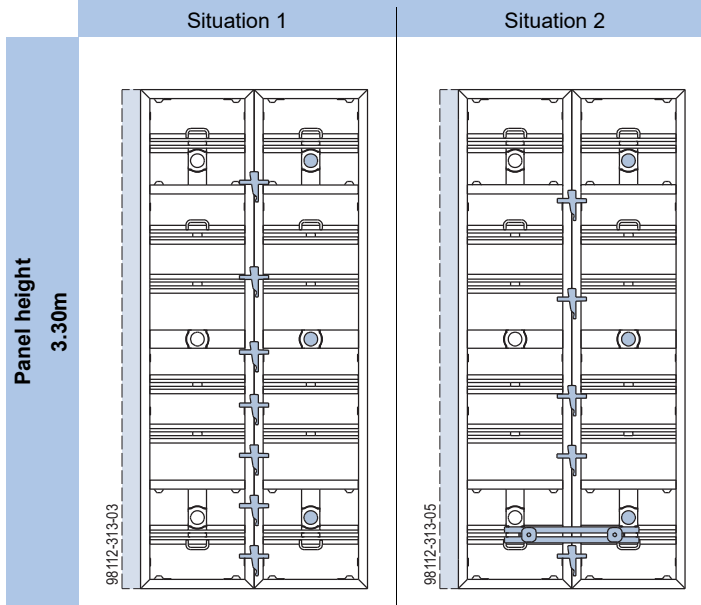

Fresh-concrete pressure $\sigma_{hk, max} = 80 \text{ kN/m}^2$ (acting on whole area)

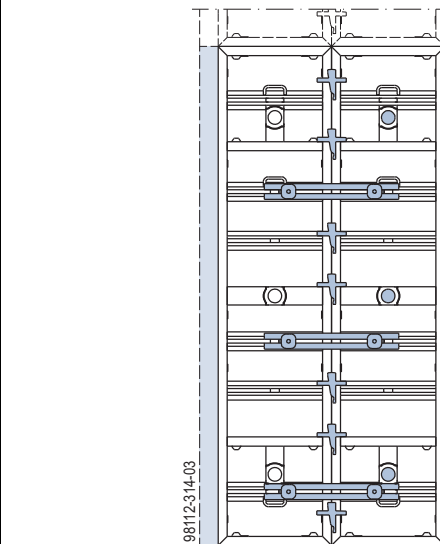

- A Outside corner (Framax Xlife plus outs. corner 10/10cm / Framax outside corner / Framax Xlife universal panel); Inter-panel connection, see the section on the outside corner used
- B Framax Xlife plus panel **0.75m** (with Framax Xlife plus outs. corner 10/10cm: **0.60m**)
- C Framax Xlife plus panel (no 1.35m wide panel or 3.00m panel on its side!)
- D Framax Xlife plus form tie 20.0
- E Framax quick acting clamp RU (or Framax multi function clamp for a closure)
- F Framax universal waling + 2 Framax wedge clamps

Alternative with Quick acting clamp RU and universal fixing bolt (fresh-concrete pressure acting on whole area)

Panel height	Quick acting clamp RU	Universal fixing bolt + Star grip nut 15.0 G
3.00 m *)	5	3
3.30 m	5	4

*) Fresh-concrete pressure max. **75 kN/m²**

Box-out in the corner zone

Note:
Box-outs in the corner zone (tying through box-out) require additional bracing with universal walings (inside and outside formwork).

T-junctions

Wall thickness up to 30 cm

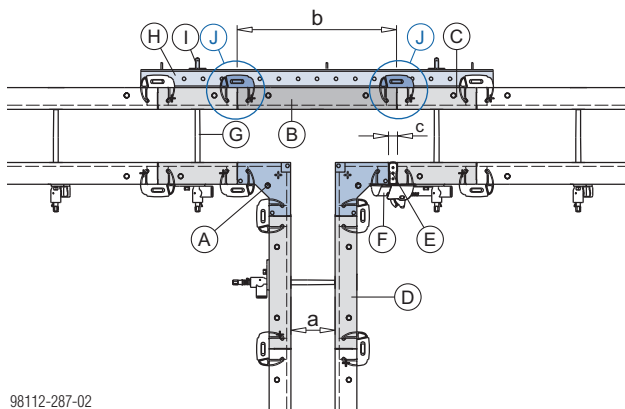
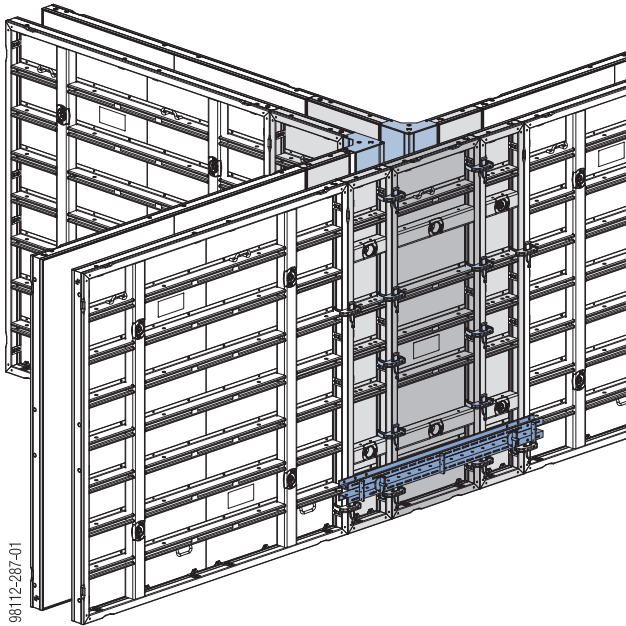

- a ... wall thickness (max. 30 cm)
 b ... panel width
 c ... closure width

- A** Framax Xlife plus inside corner 30/30cm or Framax Xlife inside corner
B Framax Xlife plus panel **0.75m / 0.90m**
C Framax Xlife plus panel (**max. width of 0.45m**)
D Framax Xlife plus panel (**no 1.35m wide panel or 3.00m panel on its side!**)
E Closure **0 - 15 cm** (Framax aluminium closure / Framax fitting timber)
F Framax multi function clamp
G Tie rod system Framax Xlife plus 20.0
H Multi-purpose waling WS10 Top50
I Framax wedge clamp
J Inter-panel connections (see section [T-junction: Inter-panel connections on Framax Xlife plus panels in the straight wall](#))

Note:

If the wall sections are short it is advisable to brace the inside corner with a **universal corner waling**.

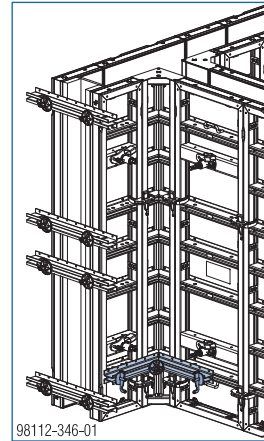

Width of the Framax Xlife plus panel in the straight wall

Wall thickness (a)	Panel width (b)
15 cm	0.75m (75 cm)
>15 - 30 cm	0.90m (90 cm)

Closure width in the inside corner

Closure width **c** =
 panel width **b** [cm] - 60 cm - wall thickness **a** [cm]

Example:

- Wall thickness = 25 cm
 => Panel width (b) = **90 cm (0.90m)**

Closure width = 90 cm - 60 cm - 25 cm = **5 cm**

Wall thickness up to 40 cm

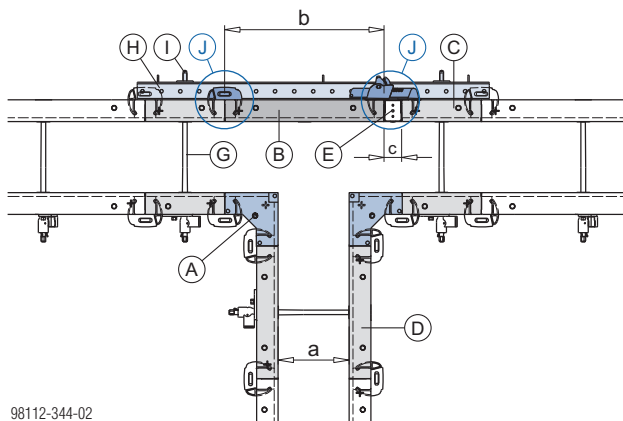
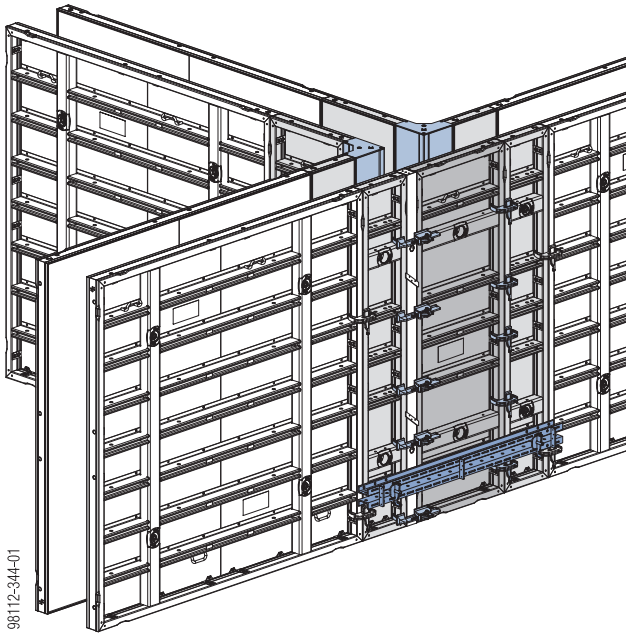

a ... wall thickness (max. 40 cm)

b ... panel width

c ... closure width

- A** Framax Xlife plus inside corner 30/30cm or Framax Xlife inside corner
- B** Framax Xlife plus panel **0.90m**
- C** Framax Xlife plus panel (**max. width of 0.30m**)
- D** Framax Xlife plus panel (**no 1.35m wide panel or 3.00m panel on its side!**)
- E** Closure **0 - 15 cm** (Framax aluminium closure / Framax fitting timber)
- G** Tie rod system Framax Xlife plus 20.0
- H** Multi-purpose waling WS10 Top50
- I** Framax wedge clamp
- J** Inter-panel connections (see section [T-junction: Inter-panel connections on Framax Xlife plus panels in the straight wall](#))

Permissible fresh-concrete pressure: 60kN/m²
(acting on whole area)

Note:

If the wall sections are short it is advisable to brace the inside corner with a **universal corner waling**.

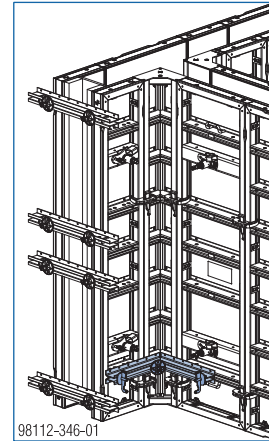
**Width of the Framax Xlife plus panel in the straight wall**

Wall thickness (a)	Panel width (b)
>30 - 40 cm	0.90m (90 cm)

Closure width in the straight wall

Closure width **c** =

60 cm + wall thickness **a** [cm] - panel width **b** [cm]

Example:

- Wall thickness = 40 cm
=> Panel width (b) = **90 cm (0.90m)**

Closure width = 60 cm + 40 cm - 90 cm = **10 cm**

Variant with the Doka tie rod system 20.0

T-junction: Inter-panel connections on Framax Xlife plus panels in the straight wall

Wall thickness from 15 to 30 cm

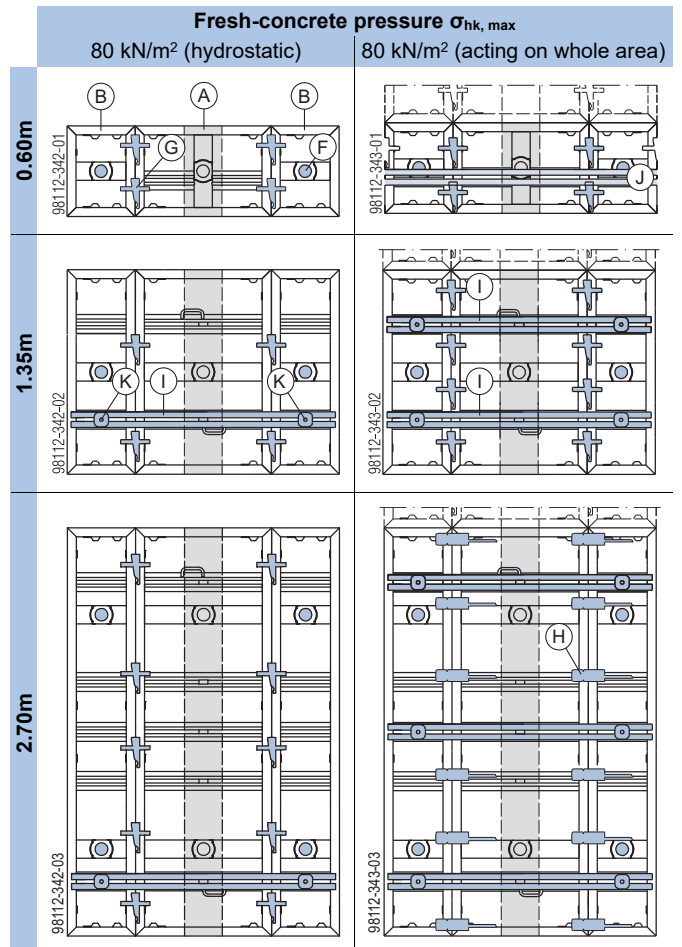

98112-279-02

a ... max. 40 cm

- A** Framax Xlife inside corner
- B** Framax Xlife panel 0.90m
- C** Closure (Framax aluminium closure / Framax fitting timber)
- D** Doka tie rod system 20.0
- E** Framax Xlife plus panel
- F** Doka tie rod system 20.0
(A form tie is only needed in this position if a Framax Xlife plus panel with a width of 1.35m is used as a connecting panel (G).)
- G** Connecting panel
- H** Tie rod system Framax Xlife plus 20.0
- I** Framax multi function clamp
- J** Framax quick acting clamp RU

Permitted fresh-concrete pressure: 80kN/m²

Alternative for each inter-panel connection (fresh-concrete pressure acting on whole area)

Panel height	Quick acting clamp RU	Universal fixing bolt + Star grip nut 15.0 G
0.60 m	1	1
1.35 m	2	2
2.70 m	4	3
3.00 m *)	4	3
3.30 m	4	4

*) Fresh-concrete pressure max. 75 kN/m²

Wall thickness from 15 to 30 cm

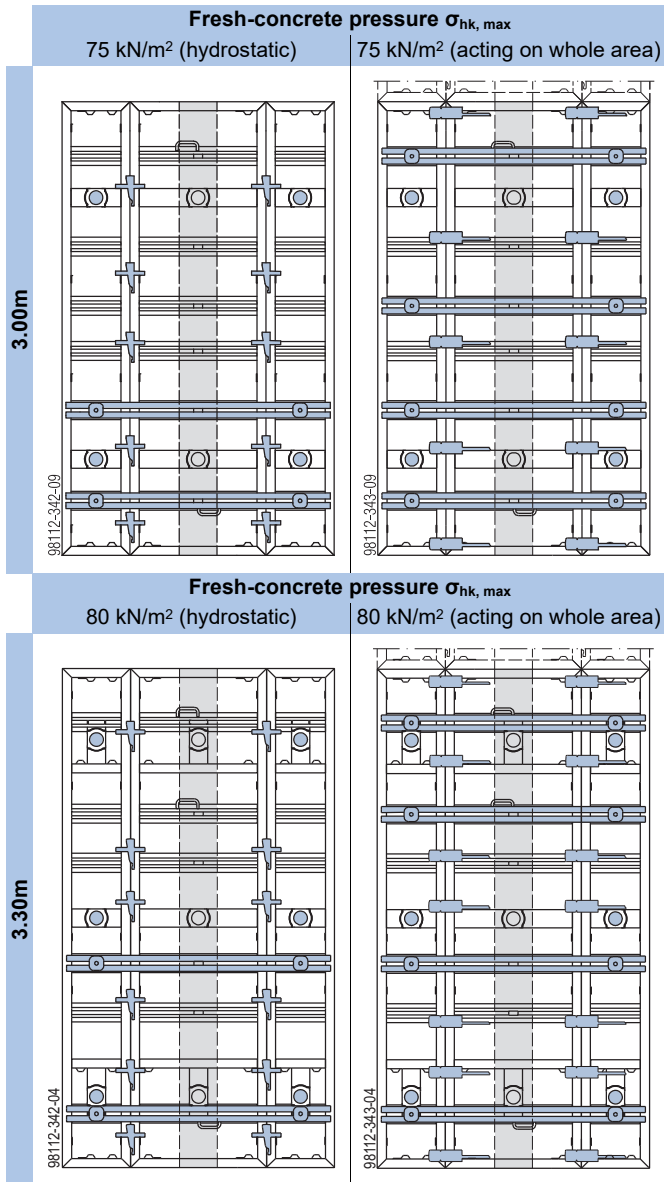

- A** Framax Xlife plus panel 0.75m or 0.90m
- B** Framax Xlife plus panel (max. width of 0.45m)
- F** Framax Xlife plus form tie 20.0
- G** Framax quick acting clamp RU
- H** Framax multi function clamp
- I** Multi-purpose waling WS10 Top50 1.75m
- J** Multi-purpose waling WS10 Top50 2.00m (fix with Framax wedge clamp to the next panel)
- K** Framax wedge clamp

Wall thickness >30 and up to 40 cm

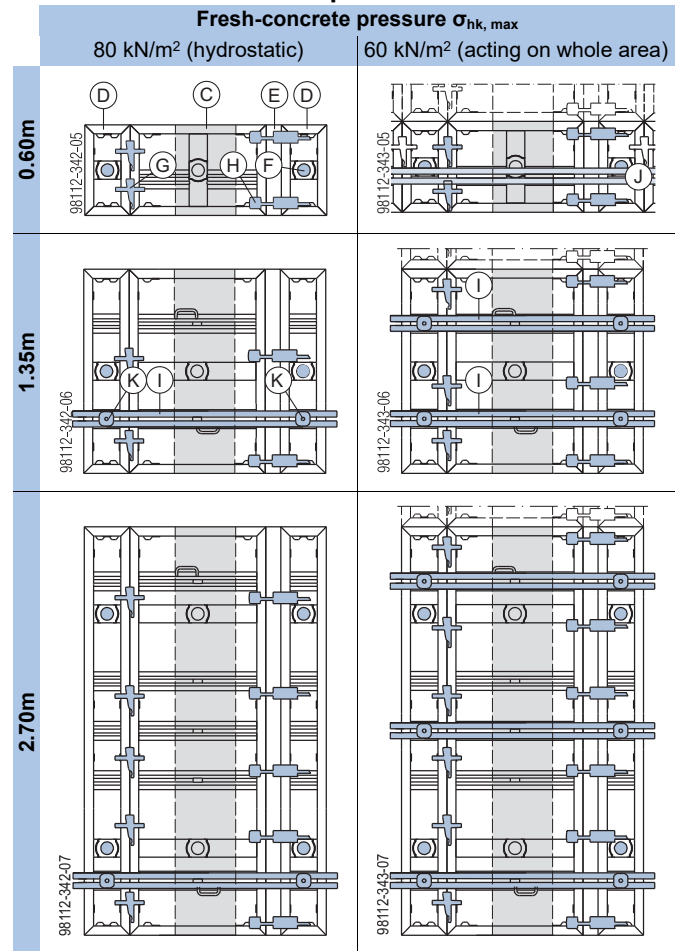

Alternative for each inter-panel connection (fresh-concrete pressure acting on whole area)

Panel height	Quick acting clamp RU	Universal fixing bolt + Star grip nut 15.0 G
0.60 m	1	1
1.35 m	2	2
2.70 m	4	3
3.00 m	4	3
3.30 m	4	4

Wall thickness >30 and up to 40 cm

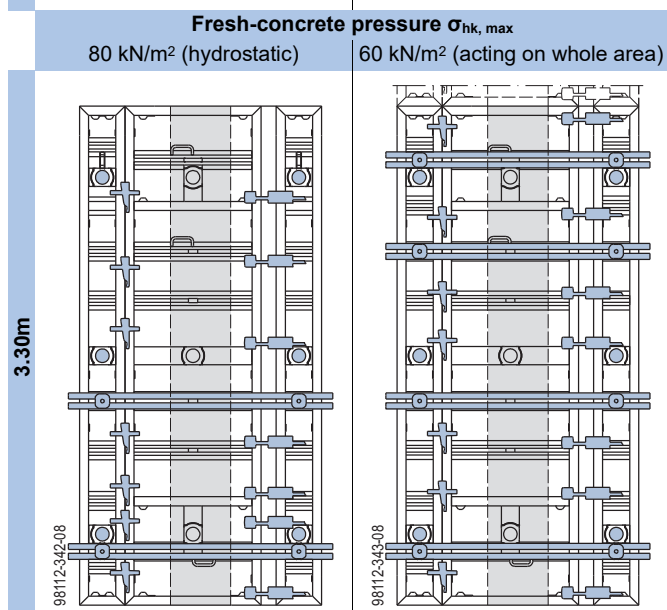
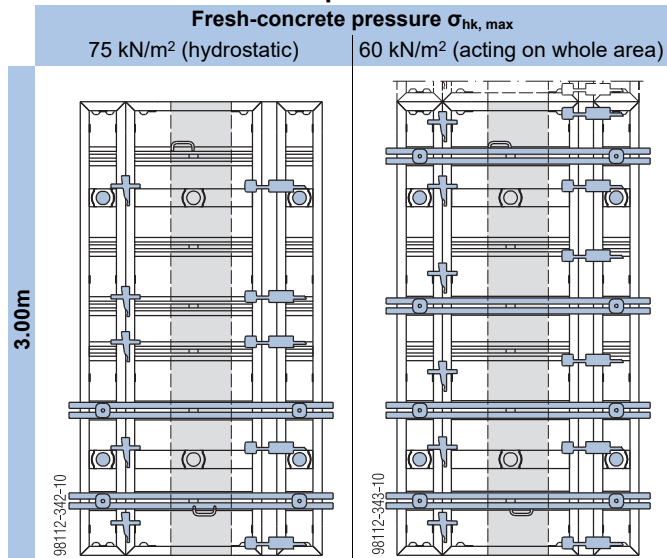

- C Framax Xlife plus panel 0.90m
- D Framax Xlife plus panel (max. width of 0.30m)
- E Closure 0 - 10 cm (Framax aluminium closure / Framax fitting timber)
- F Framax Xlife plus form tie 20.0
- G Framax quick acting clamp RU
- H Framax multi function clamp
- I Multi-purpose waling WS10 Top50 1.75m
- J Multi-purpose waling WS10 Top50 2.00m (fix with Framax wedge clamp to the next panel)
- K Framax wedge clamp

Edges

with Framax frontal triangular ledge

The Framax frontal triangular ledge can be slipped over the front end of the panel without being nailed and is used with the universal panel to form outside corners (integral slot grid for universal fixing bolts). It is also possible to form edges using the Framax triangular ledge, of course.

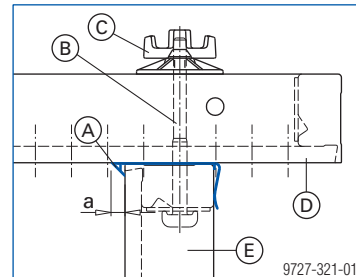

a ... 20 mm

- A Framax frontal triangular ledge or Framax triangular ledge 2.70m
- B Framax universal fixing bolt
- C Super plate 15.0
- D Framax Xlife universal panel
- E Framax Xlife plus panel

with the Framax triangular ledge

Where outside corners are formed using the Framax outside corner, the Quick acting clamps used for the interconnection mean that the Framax triangular ledge has to be used.

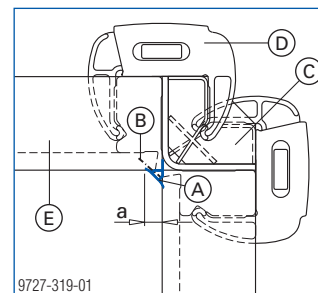

a ... 20 mm

- A Framax triangular ledge 2.70m
- B Wire nail 22x40
- C Framax outside corner
- D Framax quick acting clamp RU
- E Framax Xlife plus panel

Acute & obtuse-angled corners

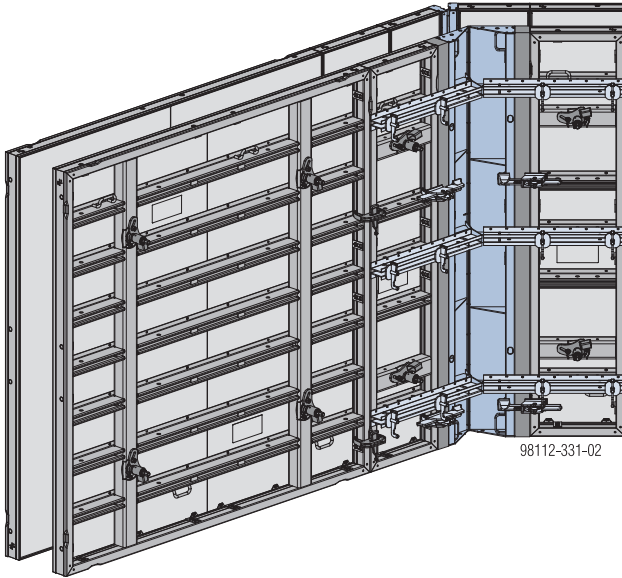

98112-331-02

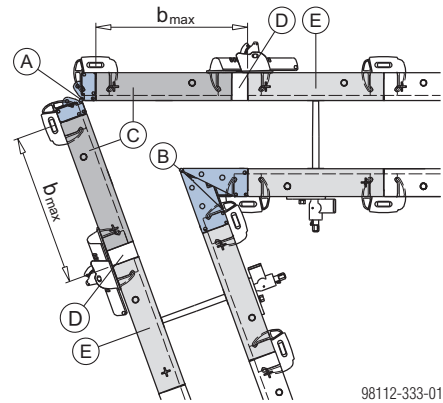

98112-333-01

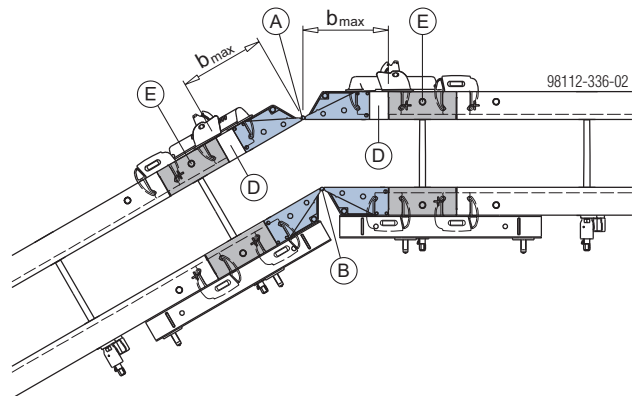

98112-336-02

Hinged inside corner I

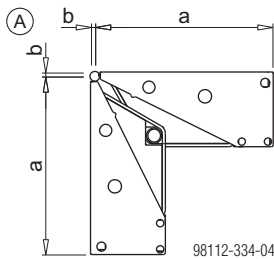

98112-334-04

a ... 29.3 cm
b ... 0.7 cm

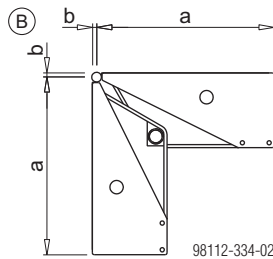

98112-334-02

a ... 29.2 cm
b ... 0.7 cm

Hinged outside corner A

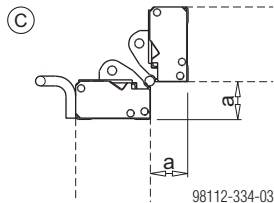

98112-334-03

a ... 6.3 cm

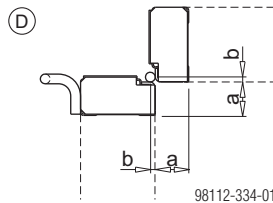

98112-334-01

a ... 5.5 cm
b ... 0.8 cm

- A Framax hinged inside corner I galv.
- B Framax hinged inside corner I
- C Framax hinged outside corner A galv.
- D Framax hinged outside corner A

Note:

Vertical stacking of the **Framax hinged outside corner A** and the **Framax hinged outside corner A galv.** on top (and vice versa) is not possible!

b_{max} (panel width + closure)	Fresh-concrete pressure $\sigma_{hk, max}$	
100 cm	80 kN/m ²	hydrostatic
80 cm	50 kN/m ²	acting on whole area
70 cm	60 kN/m ²	
60 cm	70 kN/m ²	
52 cm	80 kN/m ²	

- A Hinged outside corner (Framax hinged outside corner A or Framax hinged inside corner I)
- B Hinged inside corner (Framax hinged inside corner I)
- C Framax Xlife plus panel
- D Closure (Framax aluminium closure / Framax fitting timber)
- E Framax Xlife plus panel (max. width 0.60m)

Note:

Seal off any unneeded form-tie sleeves with the **Framax Xlife plus frame hole plug 32mm NG**.

Inside formwork

Use the **Hinged inside corner I** as the inside hinged corner to form acute and obtuse angles.

Bracing with **universal walings** is necessary for angles $\geq 120^\circ$.

Required number of universal walings:

Framax Xlife plus panel 0.60m	2
Framax Xlife plus panel 1.35m	4
Framax Xlife plus panel 2.70m	6
Framax Xlife plus panel 3.00m	6
Framax Xlife plus panel 3.30m	8

Position of the universal walings:
In every support level of the Hinged inside corner I.



NOTICE

With closures, provide additional universal walings in accordance with the section headed [Length adjustment using closures](#).

Outside formwork

The following possibilities are available as outside hinged corners for forming acute and obtuse angles:

- **Hinged outside corner A (60°-135°)**
- **Hinged inside corner I (90°-180°)**

Number of connectors needed in the hinged outside corner:

Panel height	Number of clamps
0.60 m	2
1.35 m	6
2.70 m	12
3.00 m	14
3.30 m	14

Note:

For details regarding extra inter-panel connections on outside corners (for increased tensile loads) see the section headed [Inter-panel connections for increased tensile loads](#).

Hinged outside corner A (60°-135°)

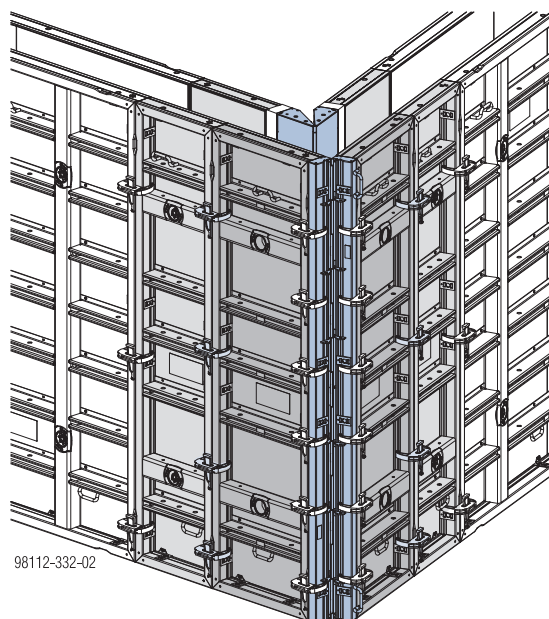

98112-332-02

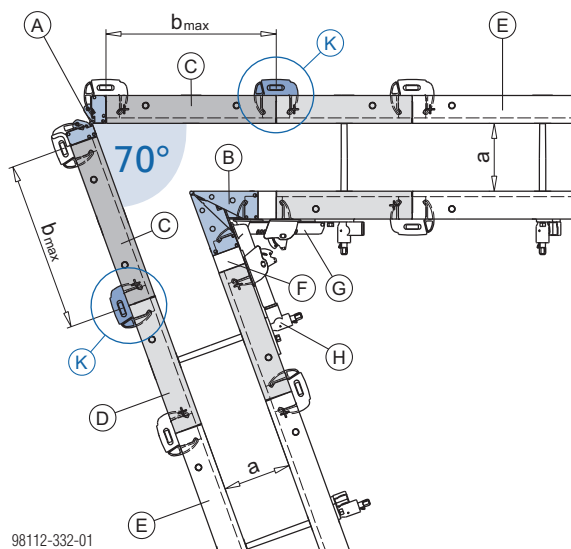

98112-332-01

a ... 30 cm

- A** Framax hinged outside corner A
- B** Framax hinged inside corner I
- C** Framax Xlife plus panel 0.75m
- D** Framax Xlife plus panel (max. width 0.60m)
- E** Framax Xlife plus panel
- F** Closure 8 cm
- G** Framax multi function clamp
- H** Tie rod system Framax Xlife plus
- K** Inter-panel connection
(see the section headed [Inter-panel connection, corner gang-form \(outside: with hinged corner\) with adjoining Framax Xlife plus panel](#))

**NOTICE****Possible collision of tie-rod and connector parts in the inside corner (angle 60°)!**

- If the inside angle is small, if necessary use universal fixing bolts and Star grip nuts 15.0 G (L) as connectors at the inside hinged corner!

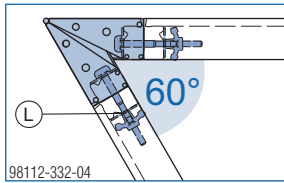

- When forming thin walls, if necessary install the Framax Xlife plus form ties (H) from the outside!

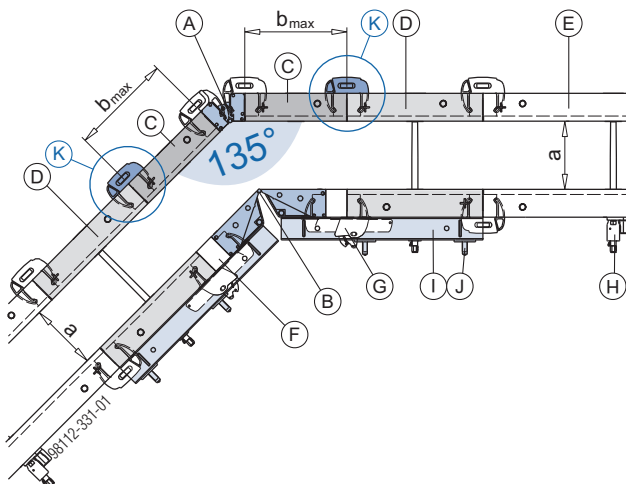
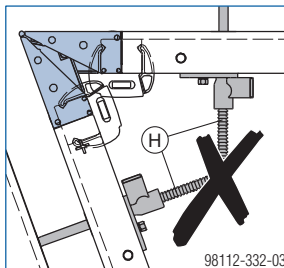

a ... 30 cm

A Framax hinged outside corner A

B Framax hinged inside corner I

C Framax Xlife plus panel 0.45m

D Framax Xlife plus panel (max. width 0.60m)

E Framax Xlife plus panel

F Closure 9 cm

G Framax multi function clamp

H Tie rod system Framax Xlife plus

I Framax universal waling 0.90m

J Framax wedge clamp

K Inter-panel connection

(see the section headed [Inter-panel connection, corner gang-form \(outside: with hinged corner\) with adjoining Framax Xlife plus panel!](#))

Hinged inside corner I (90°-180°)

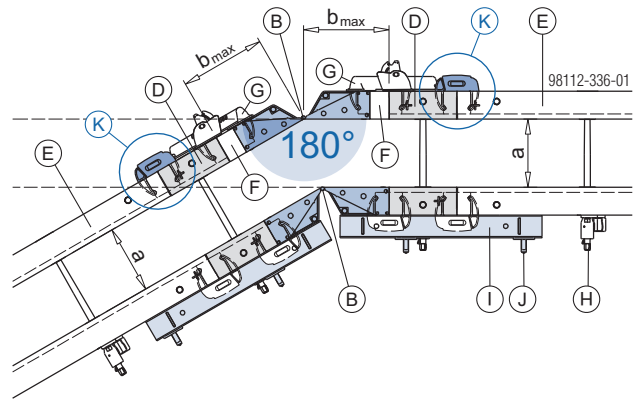
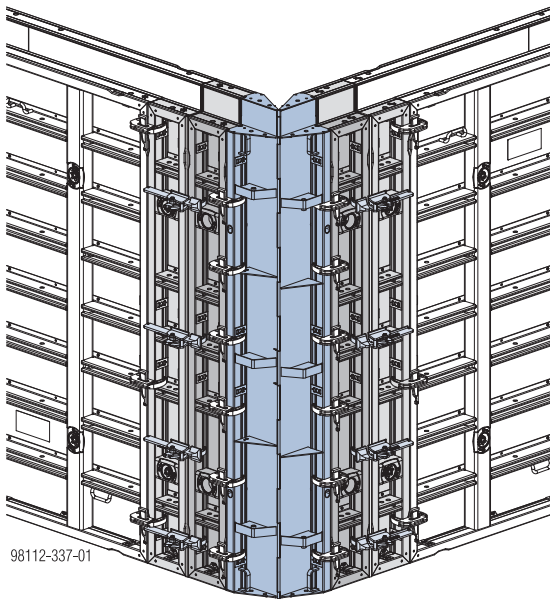

a ... 30 cm

- B** Framax hinged inside corner I
- D** Framax Xlife plus panel (max. width 0.60m)
- E** Framax Xlife plus panel
- F** Closure 8 cm
- G** Framax multi function clamp
- H** Tie rod system Framax Xlife plus
- I** Framax universal waling 0.90m
- J** Framax wedge clamp
- K** Inter-panel connection
(see the section headed [Inter-panel connection, corner gang-form \(outside: with hinged corner\) with adjoining Framax Xlife plus panel](#))

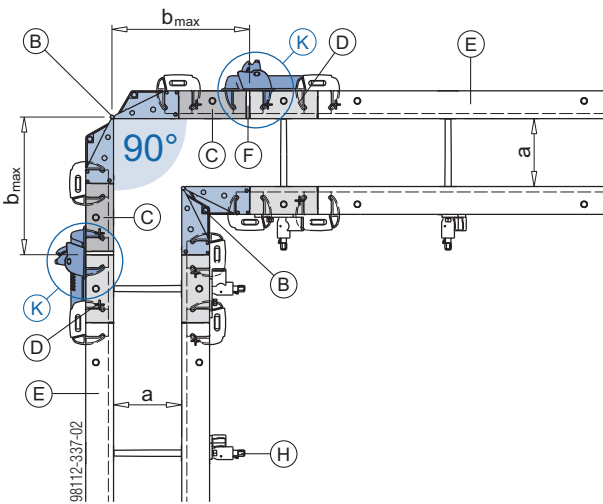

a ... 30 cm

- B** Framax hinged inside corner I
- C** Framax Xlife plus panel 0.30m
- D** Framax Xlife plus panel (max. width 0.60m)
- E** Framax Xlife plus panel
- F** Closure 2 cm
- H** Tie rod system Framax Xlife plus
- K** Inter-panel connection
(see the section headed [Inter-panel connection, corner gang-form \(outside: with hinged corner\) with adjoining Framax Xlife plus panel](#))

Note:

The hinged inside corner I can be fixed at an angle of 90° using universal fixing bolts and Super plates 15.0.

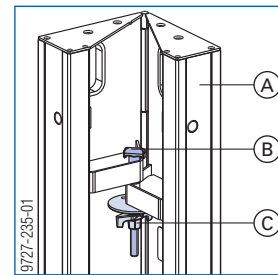

- A** Framax hinged inside corner I
- B** Framax universal fixing bolt
- C** Super plate 15.0

Inter-panel connection, corner gangform (outside; with hinged corner) with adjoining Framax Xlife plus panel

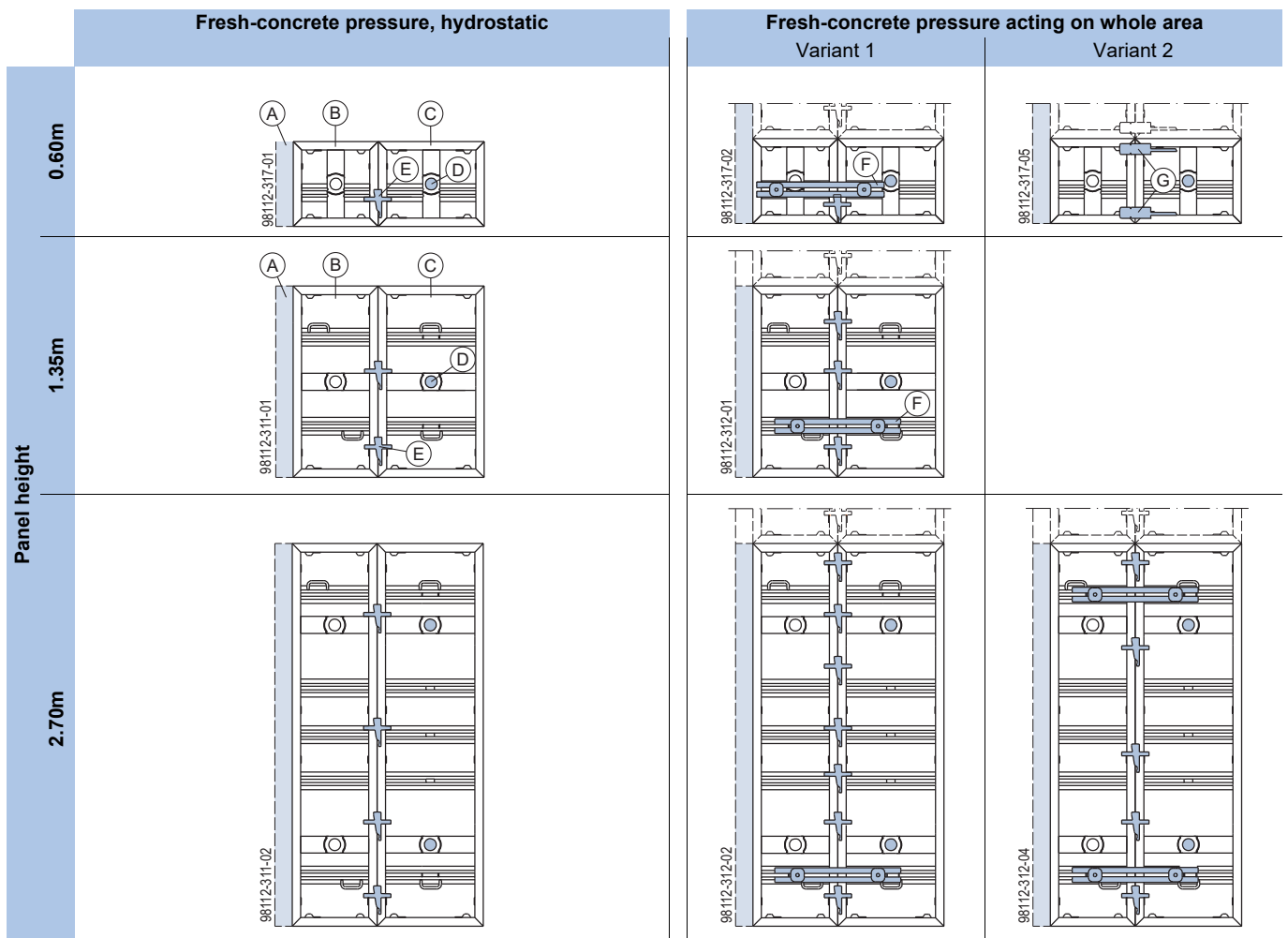

- A** Hinged outside corner *)
(Framax hinged outside corner A or Framax hinged inside corner I; Inter panel-connection, see the table 'Number of connectors needed in the hinged outside corner')
- B** Framax Xlife plus panel **0.30m - 0.75m**
- C** Framax Xlife plus panel (max. width 0.60m)
- D** Framax Xlife plus form tie 20.0
- E** Framax quick acting clamp RU
(or Framax multi function clamp for a closure)
- F** Framax universal waling + 2 Framax wedge clamps
- G** Framax multi function clamp

Alternative with Quick acting clamp RU and universal fixing bolt (fresh-concrete pressure acting on whole area)

Panel height	Quick acting clamp RU	Universal fixing bolt + Star grip nut 15.0 G
2.70 m	4	3

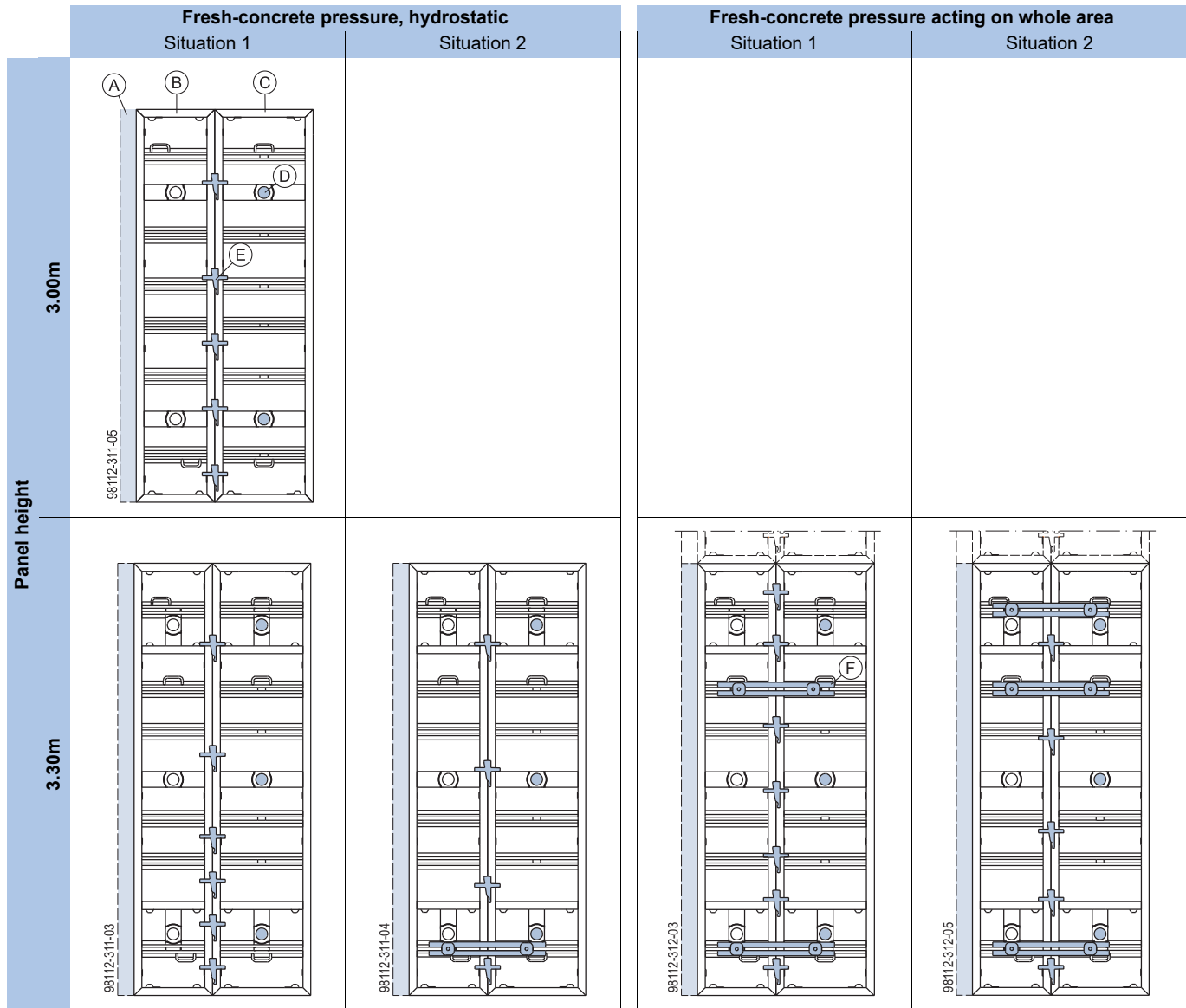

- A** Hinged outside corner *)
(Framax hinged outside corner A or Framax hinged inside corner I; Inter panel-connection, see the table 'Number of connectors needed in the hinged outside corner')
- B** Framax Xlife plus panel **0.30m - 0.75m**
- C** Framax Xlife plus panel (max. width 0.60m)
- D** Framax Xlife plus form tie 20.0
- E** Framax quick acting clamp RU
(or Framax multi function clamp for a closure)
- F** Framax universal waling + 2 Framax wedge clamps

Alternative with Quick acting clamp RU and universal fixing bolt (fresh-concrete pressure acting on whole area)

Panel height	Quick acting clamp RU	Universal fixing bolt + Star grip nut 15.0 G
3.30 m	4	4

Shaft formwork

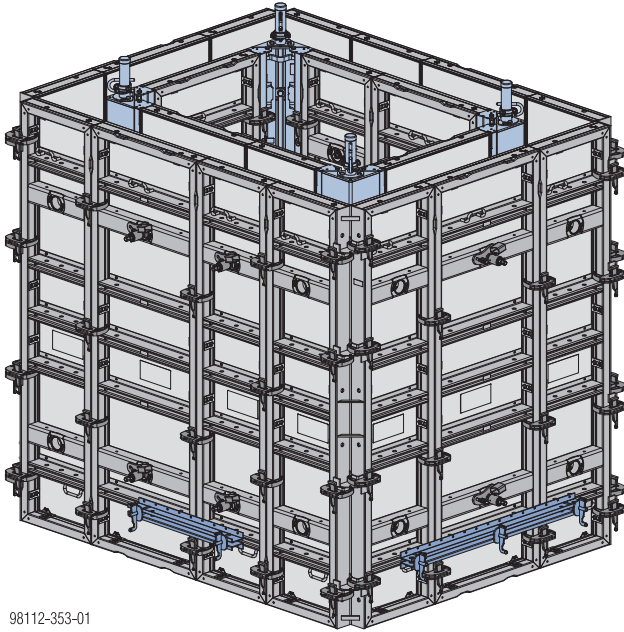

98112-353-01

Inside formwork

The **Framax-stripping corner I** is used to form right-angled inside corners in the shaft.

With it, the entire shaft formwork unit is detached from the wall in one piece and then repositioned by crane.

Product features:

- No negative impression in the concrete.
- Formwork set-up and stripping function integrated in the inside corner.
- The entire shaft formwork is repositioned in one piece.

The possibilities for setting up and stripping the formwork are as follows:

- Framax stripping spindle I
- Framax stripping spindle I with ratchet
- Framax stripping cylinder I (hydraulic)

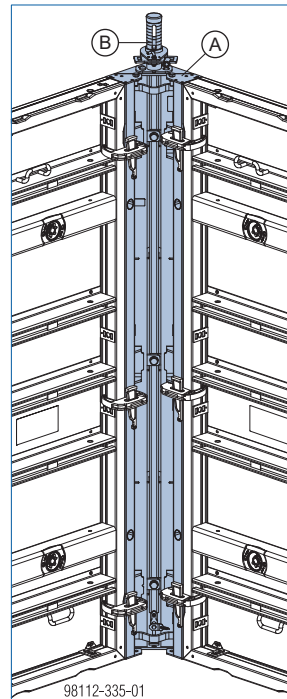

98112-335-01

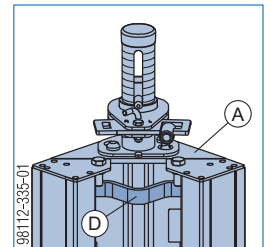

98112-335-01

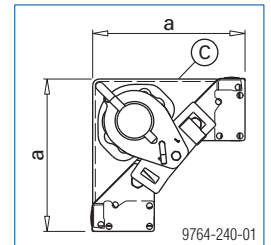

9764-240-01

a ... 30.0 cm

- A** Framax stripping corner I
- B** Framax stripping spindle I or Framax stripping spindle I with ratchet or Framax stripping cylinder I
- C** Steel form-facing
- D** Slings point (to be used exclusively for lifting **only one** stripping corner on its own!)

Required number of Framax quick acting clamps RU:

Height of the Stripping corner I	Number of clamps
1.35 m	4
2.70 m	6
3.30 m	8

Note:

In order to obtain the full available stripping-play, make sure that the Framax quick acting clamps RU are mounted at staggered heights.

Position of closures (fitting timbers) in the inside shaft formwork:

- whenever possible, not directly next to the stripping corners

Formwork-stripping clearance:

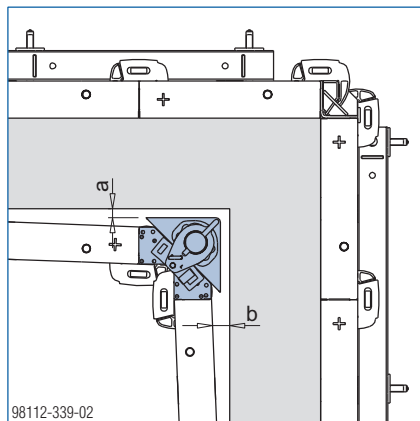
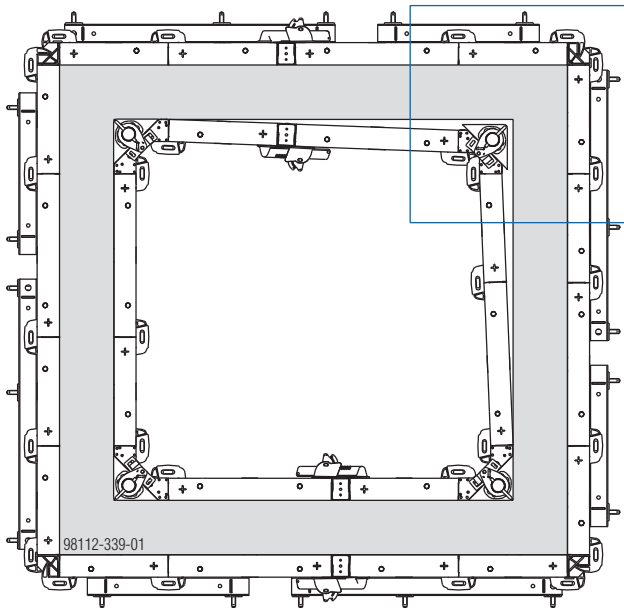

- a ... 3.0 cm
- b ... 6.0 cm

Vertical stacking of Framax stripping corners I

- ▶ Connect the bottom stripping corner to the framed formwork panel.
- ▶ Pull the coupling bolt out of the top stripping corner.
- ▶ Remove the two hexagon bolts from the bottom stripping corner.
- ▶ Engage the top stripping corner flush on the bottom stripping corner.
- ▶ Push the coupling bolt back in.
- ▶ Bolt the stripping corners together with the 2 hexagon bolts and hexagon nuts removed beforehand.
- ▶ Vertically stack the next framed formwork panel and connect it to the stripping corner.

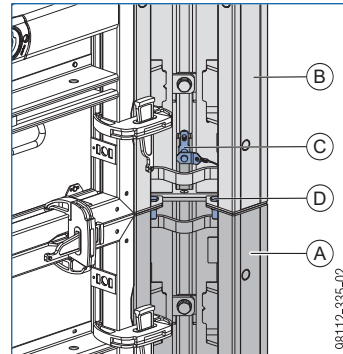

- A Bottom stripping corner I
- B Top stripping corner I
- C Coupling bolt
- D Hexagon bolt ISO 4019 M16x45 8.8 galv. +
Hexagon nut ISO 4032 M16 8 galv.

Animation:

<https://player.vimeo.com/video/256373947>

Operating the Framax stripping corner I with stripping spindle

Assembly

These assembly instructions apply to both **Stripping spindles I** and **Stripping spindles I with ratchet**.

- 1) Pull out the U-bolt from the stripping spindle.
- 2) Place the stripping spindle on the centring stud of the stripping corner.
- 3) Turn the stripping spindle clockwise until fully engaged.
- 4) Position the ratchet or spindle nut between the holes in the push rod.
- 5) Fix the stripping spindle with the U-bolt.

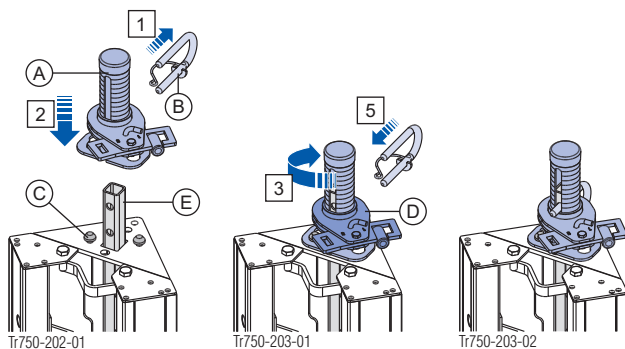

- A Framax stripping spindle I or Framax stripping spindle I with ratchet
- B U-bolt
- C Centring stud of stripping corner
- D Ratchet or spindle nut
- E Push rod

Animation:

<https://player.vimeo.com/video/256374622>

Operating the Framax stripping spindle I with ratchet

- ▶ Screw a Tie-rod 15.0mm into the Weldable coupler 15.0 of the ratchet.
- ▶ **Setting up:**
 - shift the change-over lever into the 'L' position
 - turn the ratchet **clockwise**
- ▶ **Stripping:**
 - shift the change-over lever into the 'R' position
 - turn the ratchet **anti-clockwise**.

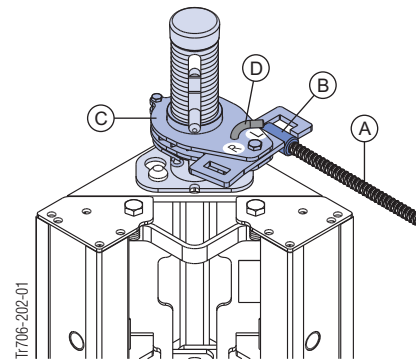

- A Tie-rod 15.0mm
- B Weldable coupler 15.0
- C Ratchet
- D Change-over lever

Operating the Framax stripping spindle I

- ▶ Push a Tie rod 15.0mm through one of the holes in the spindle nut.
- ▶ **Setting up:** Twist the spindle nut **clockwise**.
- ▶ **Stripping:** Twist the spindle nut **anti-clockwise**.

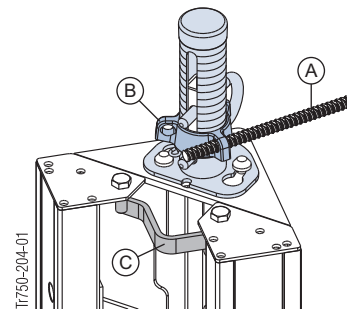

- A Tie rod 15.0mm
- B Spindle nut
- C Slinging point (to be used exclusively for lifting **only one** stripping corner on its own!)

Operation of the Framax stripping corner I hydraulic

With the **Framax stripping cylinder I**, formwork up to 5.40m high can be erected and stripped hydraulically.

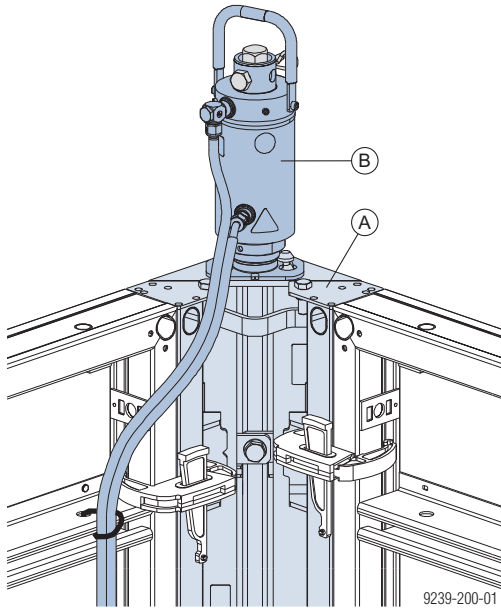

- A Framax stripping corner I
- B Framax stripping cylinder I



NOTICE

It is not permissible to install the stripping cylinder on a stripping corner that does not have a hole for the locking pin!

This hole is a standard feature of all stripping corners manufactured from 2005 onward.

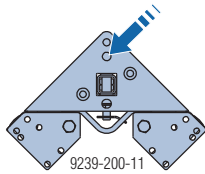

Depending on requirements, the Framax stripping cylinder I can be used with various hydraulic units and accessories.

Compatible hydraulic units

- Battery hydraulic unit V2.5 200bar DA
- Hydraulic unit Framax V4 with
 - Cordless screwdriver 18 V (1800 rotation/min)
- Hydraulic unit V45 50/60Hz with
 - System pressure controller Xclimb 60 V45
- Hydraulic unit SCP V1200 50/60Hz with
 - Coupling adapter Framax stripping cylinder I



Follow the directions in the 'Framax stripping corner I hydraulic' Operating Instructions!

Lifting by crane

Framax lifting hook

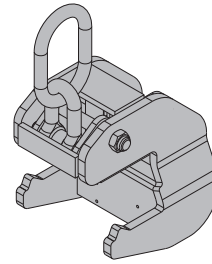

Follow the Operating Instructions!

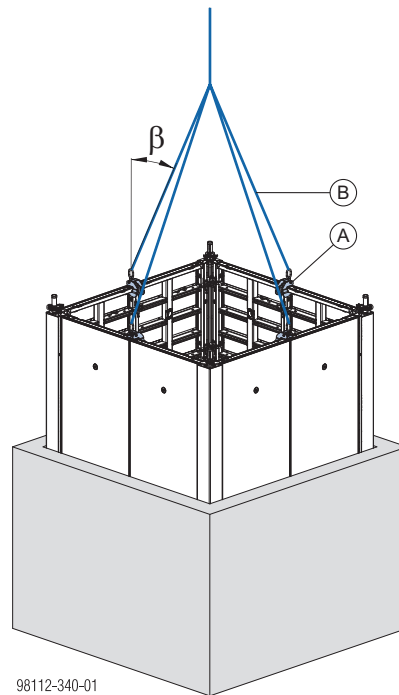

β ... max. 15°

- A Framax lifting hook
- B 4-part lifting chain

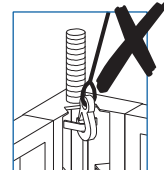
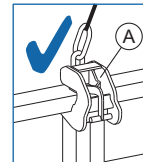

98112-339-03



Do not use the slinging point on the Stripping corner I for lifting the shaft formwork.

- ▶ The shaft formwork **may only be lifted using lifting hooks.**

Permitted weight of the shaft formwork:
4000 kg with 4 Framax lifting hooks



Use a lifting beam for repositioning large gang-forms.

Outside formwork

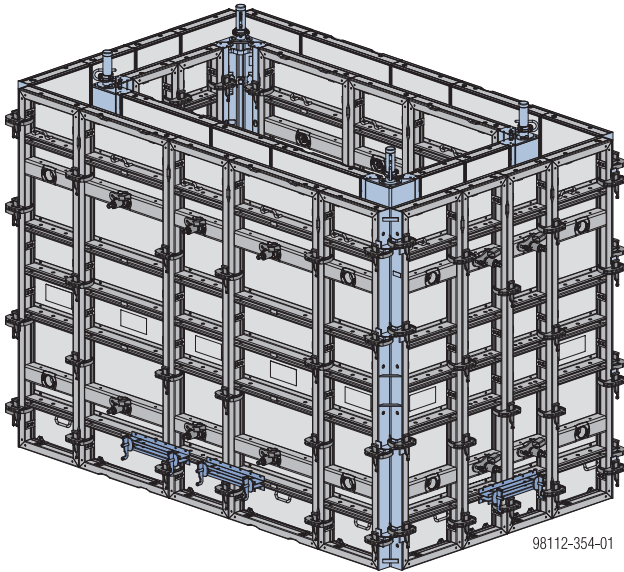

Bracing



NOTICE

Position Framax wedge clamps close to the Framax Xlife plus tie and close to the outside corner.

in corner zones

Note:

For instructions on forming right-angled outside corners and on bracing in the corner zone, see the section headed [90 degree corners!](#)

in the straight wall



NOTICE

If more than three single form-tie panels are used next to each other in the shaft, bracing with universal walings is required.

Note:

- Position the universal walings in such a way that **at most two single form-tie panels without bracing are placed side by side.**
- Always position universal walings **at the second inter-panel joint away from each corner.**
- Always position the universal walings **in the bottom function profile.**
- **Max. closure width** between the single form-tie panels: **15 cm** using the **Framax multi function clamp**

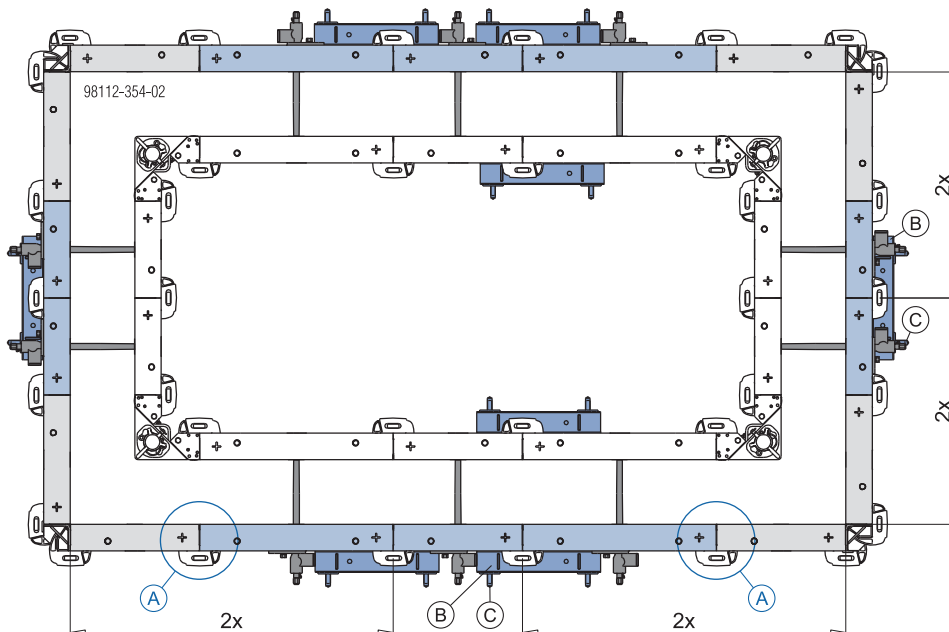

x ... panel joint

- A** Inter-panel connections
(see section [Inter-panel connection, corner gangform \(outside\) with adjoining Framax Xlife plus panel](#))
- B** Framax universal waling
- C** Framax wedge clamp

Shaft widths with only one form tie

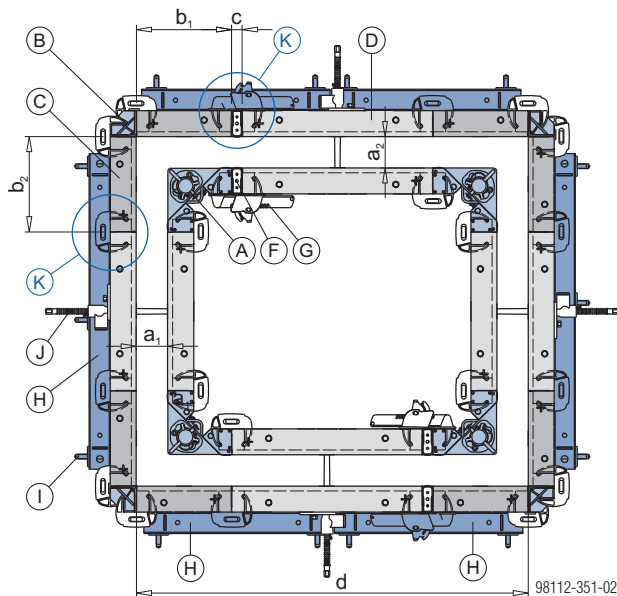

$a_{1,2}$... wall thickness

$b_{1,2}$... panel width (depends on the outside corner used, see the section headed [90 degree corners](#))

c ... closure width

d ... shaft width on the outside = max. 2.10 m

A Framax stripping corner I

B Outside corner (Framax Xlife plus outs. corner 10/10cm / Framax outside corner / Framax Xlife universal panel)

C Framax Xlife plus panel **0.45m - 0.75m**

D Framax Xlife plus panel (**max. width of 0.90m**)

F Closure **0 - 15 cm** (Framax aluminium closure / Framax fitting timber)

G Framax multi function clamp

H Framax universal waling

I Framax wedge clamp

J Tie rod system Framax Xlife plus 20.0

K Inter-panel connection

(see the section headed [Inter-panel connections, outside formwork for shaft widths with only one form tie](#))

Inter-panel connections, outside formwork for shaft widths with only one form tie

Wall thickness from 15 to 30 cm

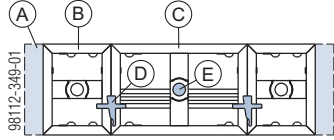
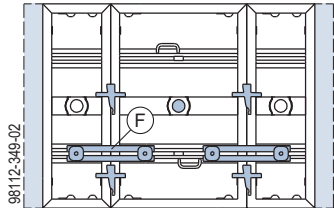
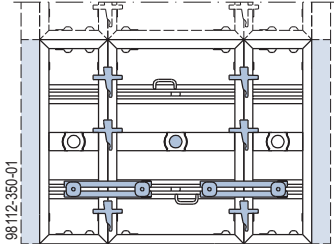
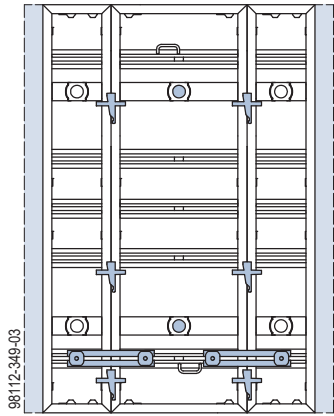
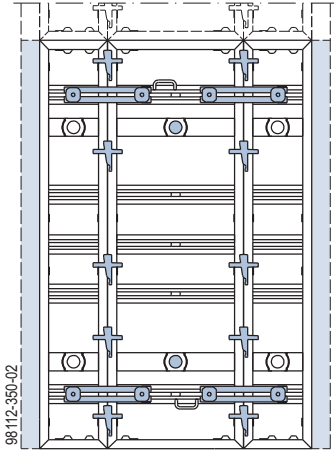
		Fresh-concrete pressure $\sigma_{hk, max}$	
		80 kN/m ² (hydrostatic)	80 kN/m ² (acting on whole area)
Panel height	0.60m		
	1.35m		
	2.70m		

A Outside corner (Framax Xlife plus outs. corner 10/10cm / Framax outside corner / Framax Xlife universal panel); Inter-panel connection, see the section on the outside corner used

B Framax Xlife plus panel **0.45m - 0.60m**

C Framax Xlife plus panel (**max. width of 0.90m**)

D Framax quick acting clamp RU
(or Framax multi function clamp for a closure)

E Framax Xlife plus form tie 20.0

F Framax universal waling + 2 Framax wedge clamps

Wall thickness from 15 to 30 cm

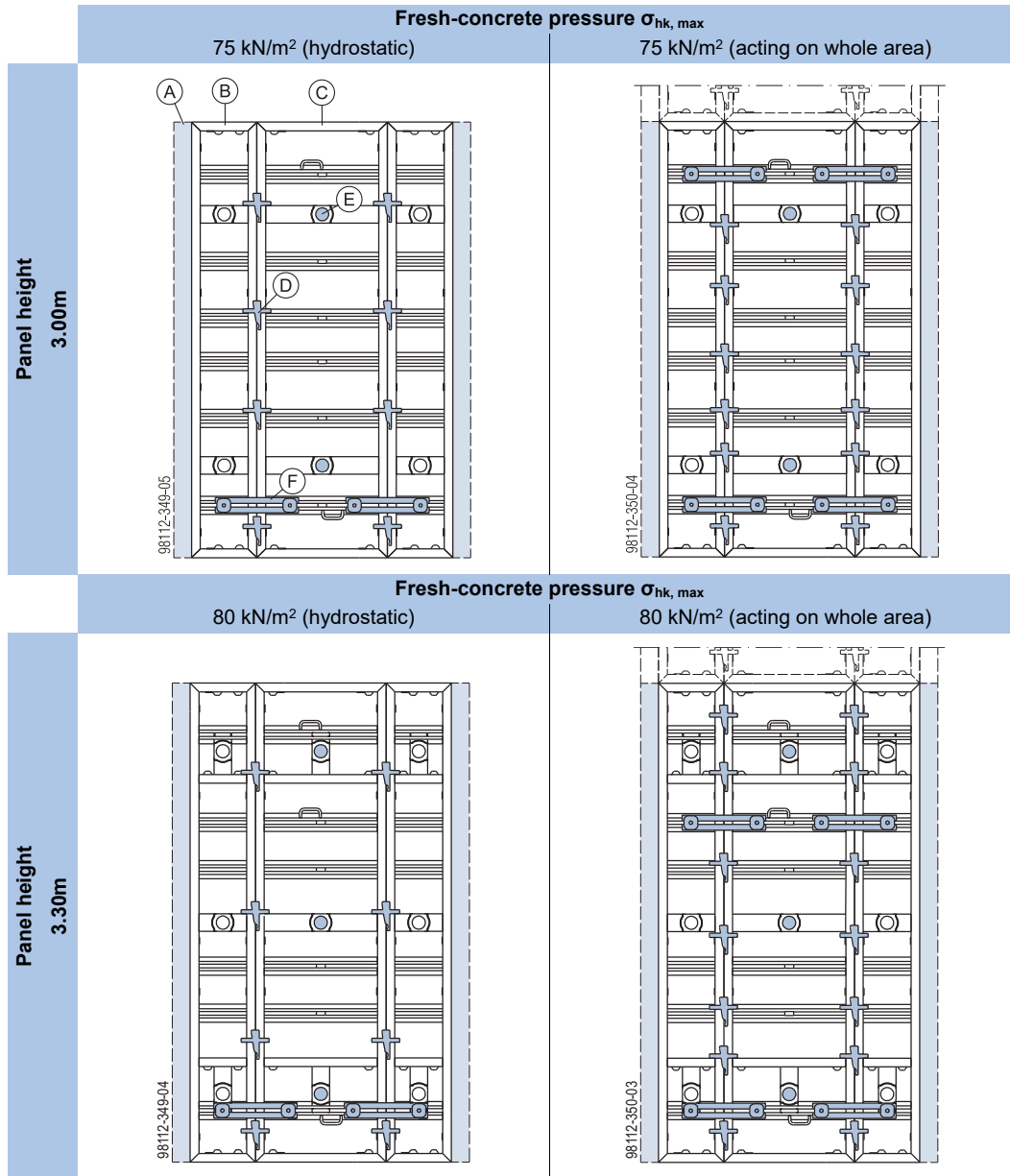

A Outside corner (Framax Xlife plus outs. corner 10/10cm / Framax outside corner / Framax Xlife universal panel); Inter-panel connection, see the section on the outside corner used

B Framax Xlife plus panel **0.45m - 0.60m**

C Framax Xlife plus panel (**max. width of 0.90m**)

D Framax quick acting clamp RU
(or Framax multi function clamp for a closure)

E Framax Xlife plus form tie 20.0

F Framax universal waling + 2 Framax wedge clamps

Wall thickness >30 and up to 40 cm

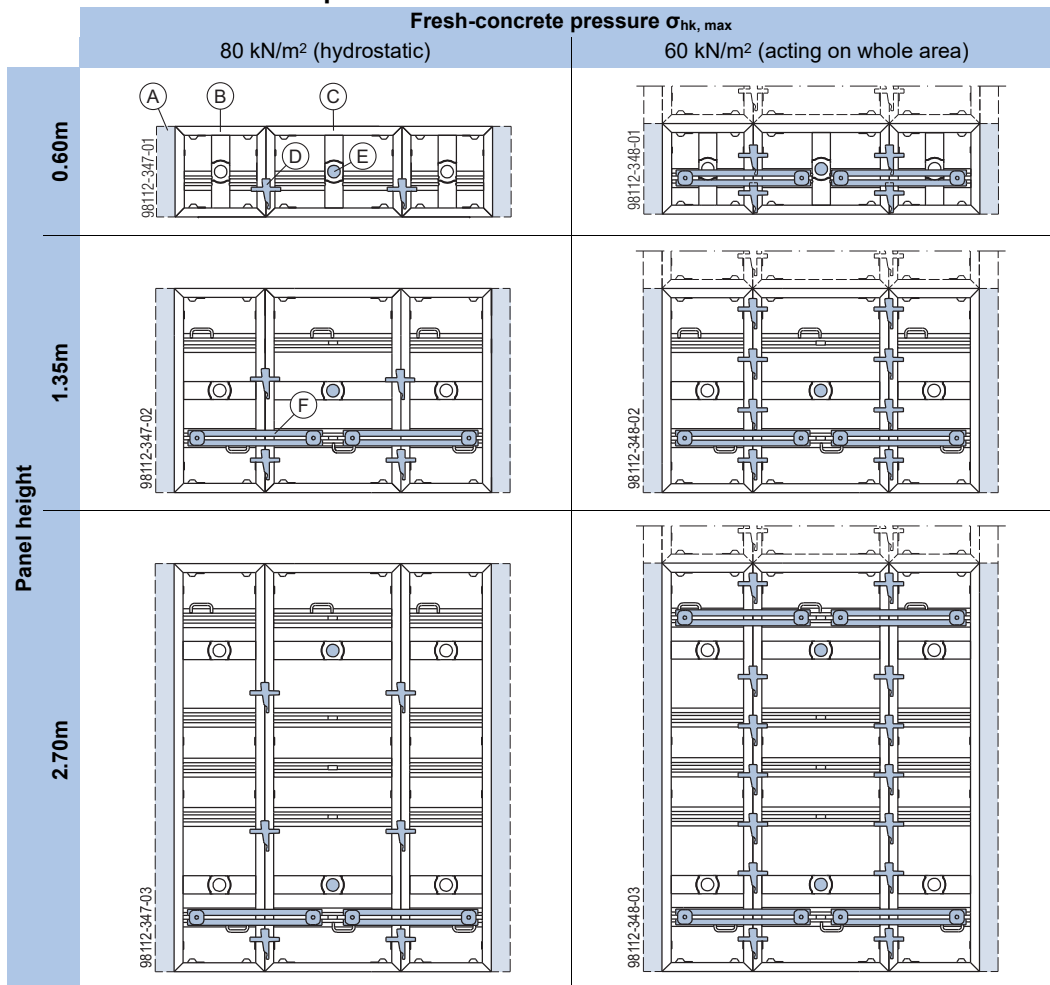

A Outside corner (Framax Xlife plus outs. corner 10/10cm / Framax outside corner / Framax Xlife universal panel); Inter-panel connection, see the section on the outside corner used

B Framax Xlife plus panel **0.60m or 0.75m**

C Framax Xlife plus panel (**max. width of 0.90m**)

D Framax quick acting clamp RU
(or Framax multi function clamp for a closure)

E Framax Xlife plus form tie 20.0

F Framax universal waling + 2 Framax wedge clamps

Wall thickness >30 and up to 40 cm

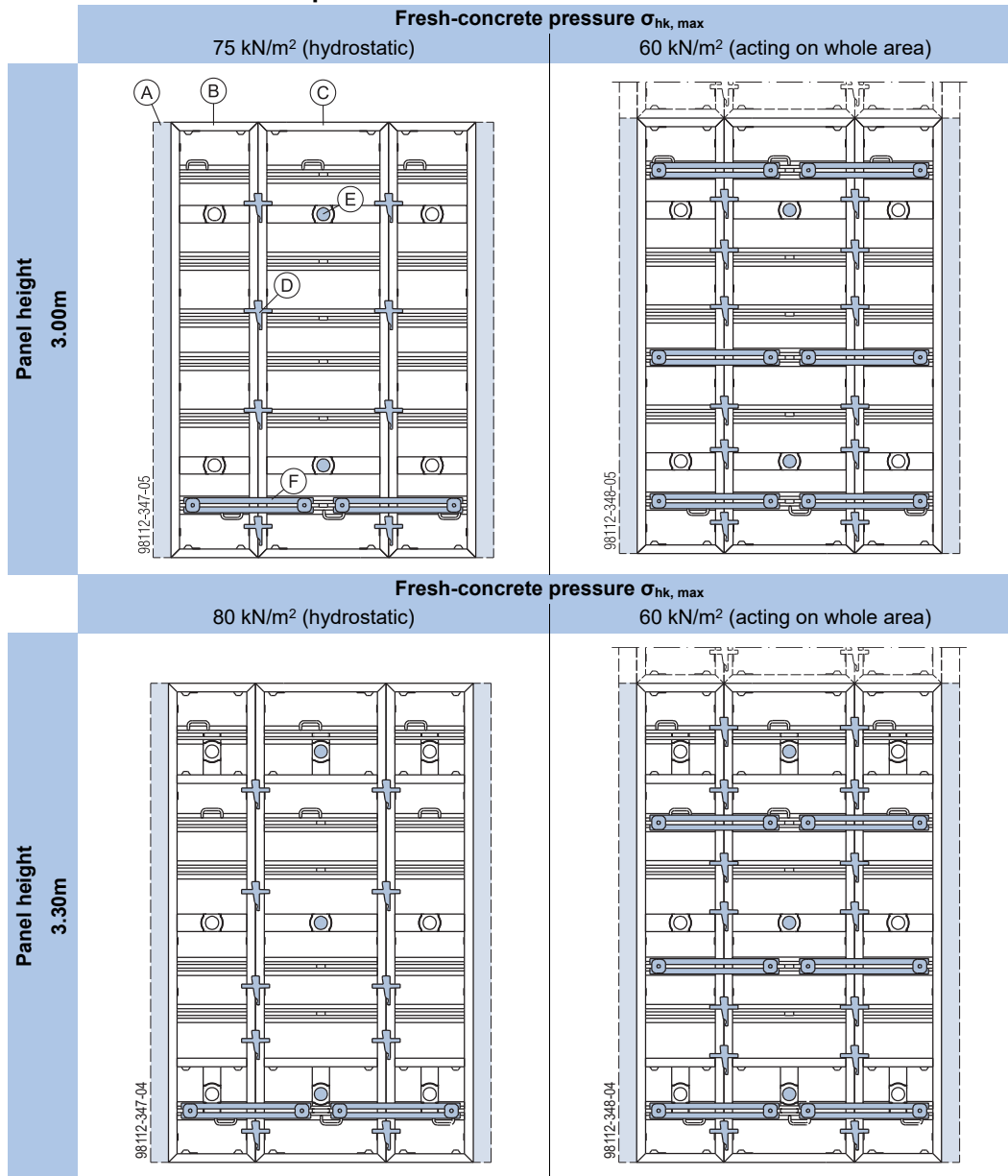

A Outside corner (Framax Xlife plus outs. corner 10/10cm / Framax outside corner / Framax Xlife universal panel); Inter-panel connection, see the section on the outside corner used

B Framax Xlife plus panel **0.60m or 0.75m**

C Framax Xlife plus panel (**max. width of 0.90m**)

D Framax quick acting clamp RU
(or Framax multi function clamp for a closure)

E Framax Xlife plus form tie 20.0

F Framax universal waling + 2 Framax wedge clamps

Shaft for use of self-compacting concrete



NOTICE

For use of self-compacting concrete (SCC), note the following:

For bracing **across the entire width of the shaft, use a single, full-length waling** (instead of two or more universal walings)!

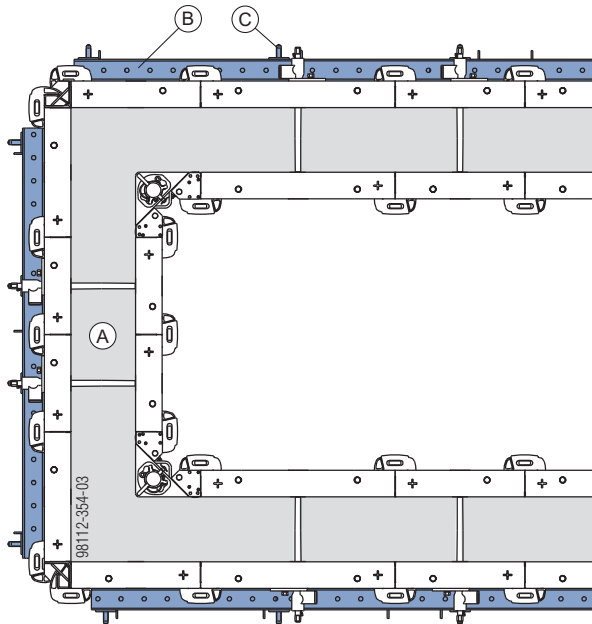

A Self-Compacting Concrete (SCC)

B Multi-purpose waling WS10 Top50

C Framax wedge clamp

Inter-panel connections for increased tensile loads

As a rule, only **2 clamps** are needed per **2.70 m**, **3 clamps per 3.00 m** and **3 clamps per 3.30 m** formwork height as a tension link between the panels.

However, where **increased tensile loads** need to be sustained near outside corners and stop-ends, **extra inter-panel connectors are needed**.

Wall thickness up to 40 cm:

- For each inter-panel joint up to 1.35 m
 - 1 additional clamp

Near stop-ends

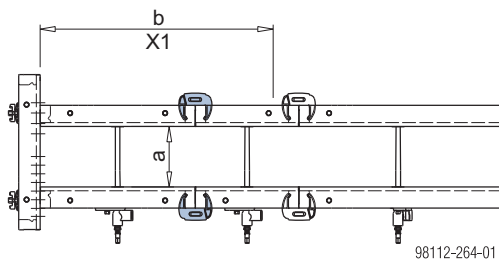

a ... up to 40 cm

b ... 1.35 m

X1 ... 1 additional clamp

Near outside corners

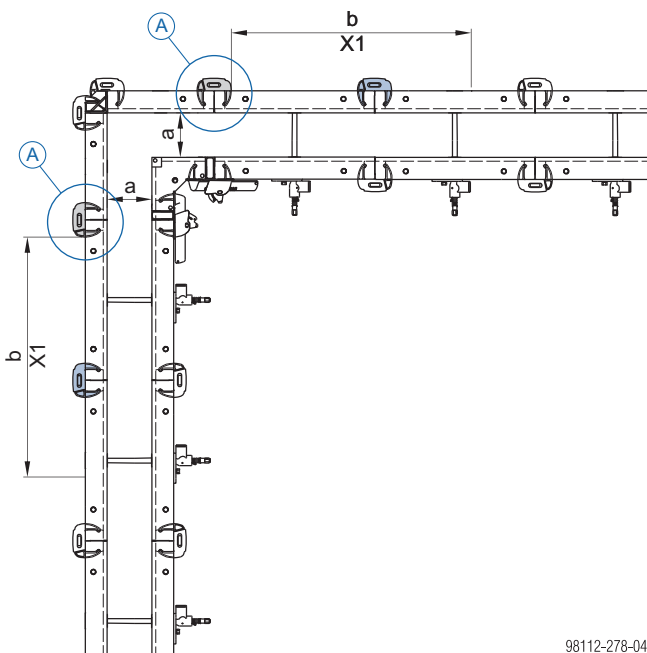

a ... up to 40 cm

b ... 1.35 m

X1 ... 1 additional clamp

A Inter-panel connection (see the section headed [Inter-panel connection, corner gangform \(outside\) with adjoining Framax Xlife plus panel](#))

Stop-end formwork

There are **3 ways** of forming **stop-ends**:

- with universal waling
- with stop-end waler tie
- with universal panel

Note:

For details regarding extra inter-panel connections on stop-ends (for increased tensile loads) see the section headed [Inter-panel connections for increased tensile loads](#).

with universal walings

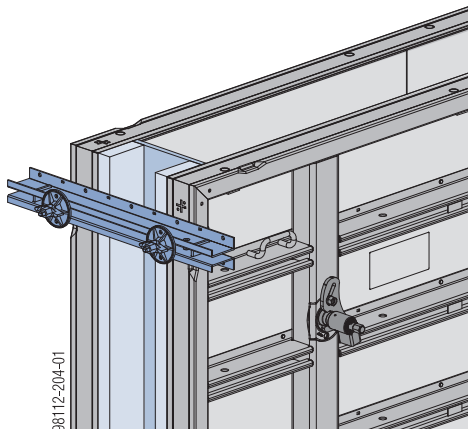

Universal walings make it possible to form **stop-ends continuously across any thickness of wall**.

They are mounted using universal fixing bolts and Super plates 15.0 fixed through the cross boreholes in the panels.

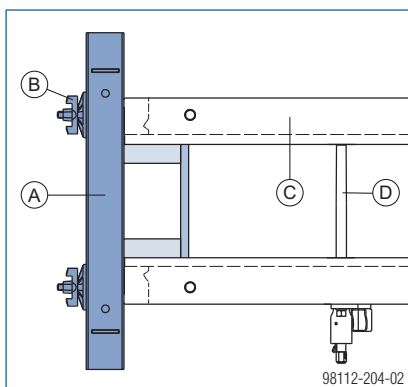

- A Framax universal waling
- B Framax universal fixing bolt + Super plate 15.0
- C Framax Xlife plus panel (panel width > 0.30m)
- D Doka tie rod system

Framax universal waling:

Permitted moment: 5.2 kNm

Framax universal fixing bolt:

permitted tensile force in the cross borehole of the Framax Xlife plus panel: 25.0 kN

with stop-end waler ties

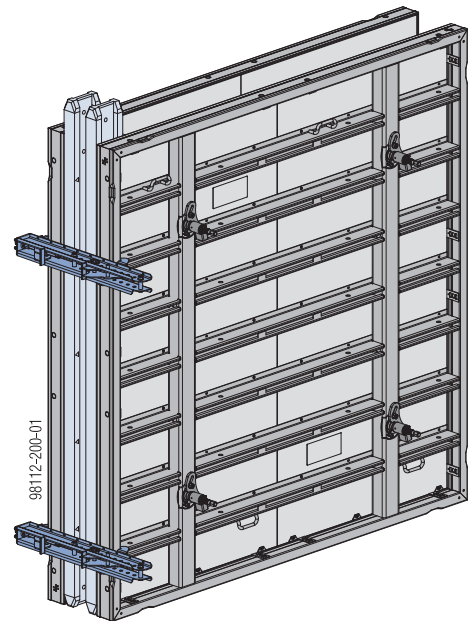

The stop-end waler ties make it possible to form stop-ends continuously from wall thicknesses of 15 cm to 45 cm.

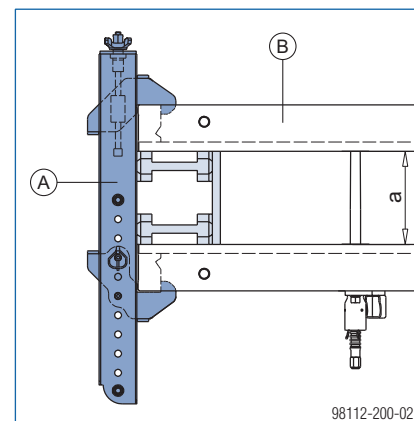

a ... 15 to 45 cm

- A Framax stop-end waler tie
- B Framax Xlife plus panel

Position of stop-end waler tie:

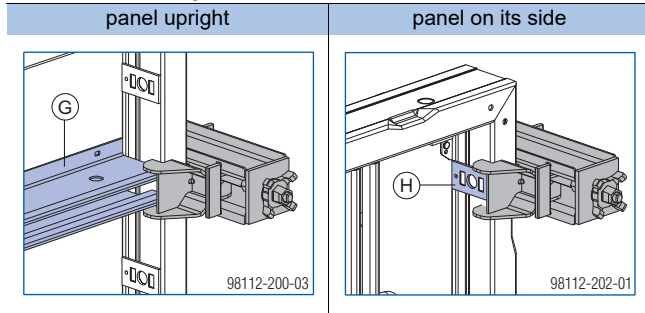

- G Function profile
- H Cross-borehole plate

Installation:

- ▶ Fix the required wall thickness with double bolts.
- ▶ Position the stop-end waler tie on the formwork.
- ▶ Fine-adjust the screwjack clamp with the star grip nut, and tighten it.

Stop-end waler tie 15-45cm

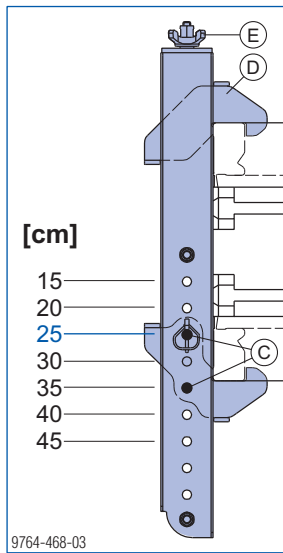

- C Double bolt
- D Screwjack clamp
- E Star grip nut

Required numbers of Framax stop-end waler ties

Panels upright			
Panel height	2.70 m	3.00 m	3.30 m
	2	3	3

Panels on their sides		
Panel width	0.30 m - 0.60 m	0.75 m - 1.35 m
	1	2

Positions of Framax stop-end waler ties

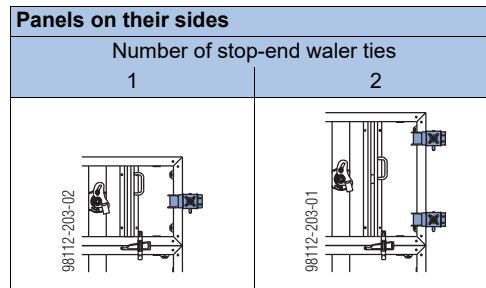
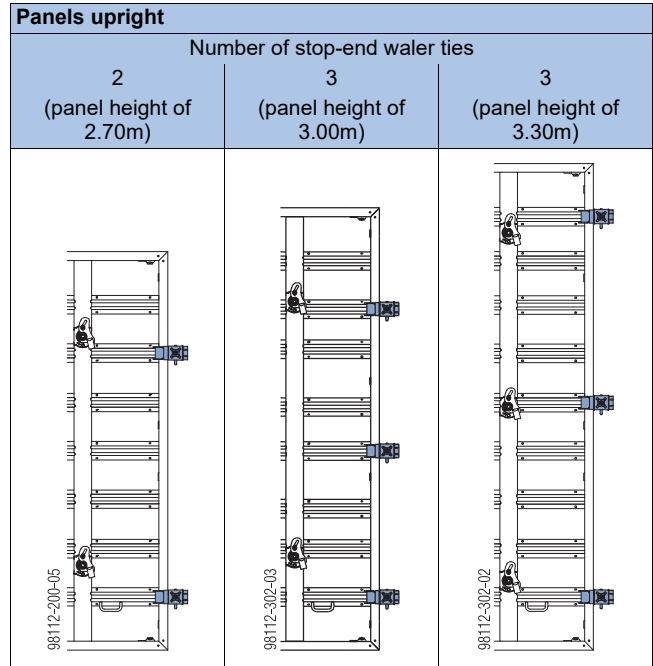

with universal panels

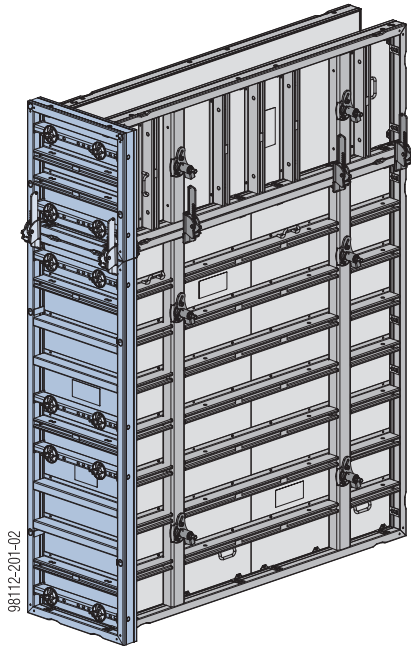

The universal panels are mounted using universal fixing bolts and Super plates 15.0.

Required numbers of universal fixing bolts + Super plates 15.0:

Universal panel 0.90m	4
Universal panel 1.35m	4
Universal panel 2.70m	8
Universal panel 3.00m *)	10
Universal panel 3.30m	10

*) Framax Xlife plus universal panel

Note:

Seal off the unused holes in the formwork sheet of the universal panels with **Framax plugs R 24.5**.

Universal panel 0.90m, 1.35m and 2.70m

The stop-end formwork can be **flexibly adapted to different wall thicknesses** by the two integrated hole-grids.

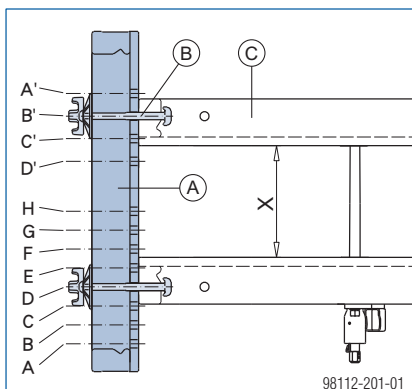

- A Framax Xlife universal panel 0.90m
- B Framax universal fixing bolt + Super plate 15.0
- C Framax Xlife plus panel (panel width > 0.30m)

Combination	Wall thickness X	
A' with H to A	16 to 51 cm	in 5 cm increments
B' with H to A	10 to 45 cm	
C' with H to A	4 to 39 cm	
D' with G to A	3 to 33 cm	

Universal panel 3.30m

The continuous **5 cm hole-grid** makes it possible to form stop-ends on walls of **up to 60 cm thick**.

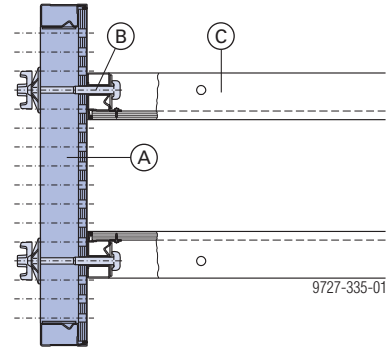

- A Framax Xlife universal panel 0.90m
- B Framax universal fixing bolt + Super plate 15.0
- C Framax Xlife plus panel (panel width > 0.30m)

Stop-ends with joint-sealing tapes

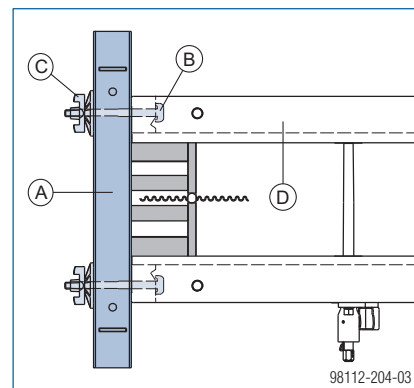

- A Framax universal waling or Multi-purpose waling WS10 Top50
- B Framax universal fixing bolt
- C Super plate 15.0
- D Framax Xlife plus panel

Wall junctions, offsets and steps

Connecting to existing walls

Right-angled connections

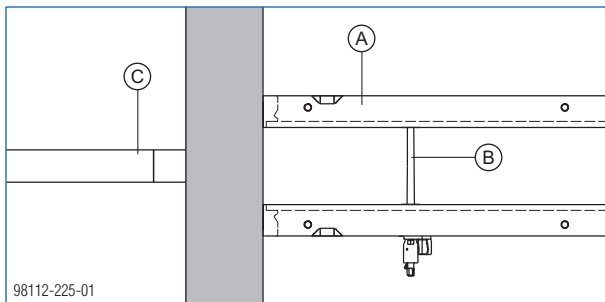

- A** Framax Xlife plus panel
- B** Tie rod system Framax Xlife plus 20.0
- C** Timber brace

In-line connections

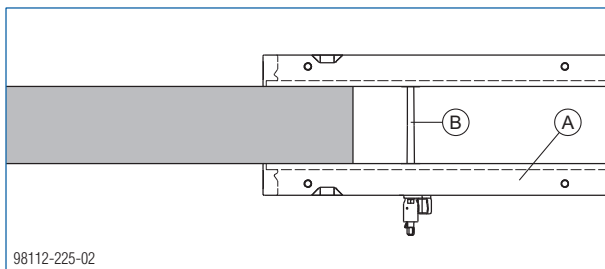

- A** Framax Xlife plus panel
- B** Tie rod system Framax Xlife plus 20.0

Corner connections

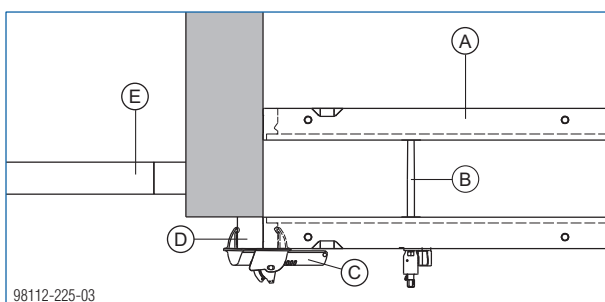

- A** Framax Xlife plus panel
- B** Tie rod system Framax Xlife plus 20.0
- C** Framax multi function clamp
- D** Squared timber
- E** Timber brace

Wall steps

Wall step of 10 cm

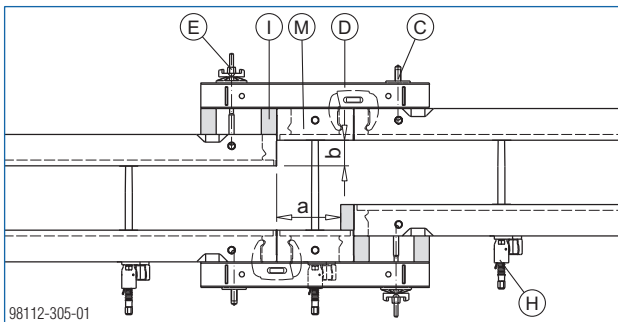

a ... 30 cm

b ... 10 cm

- C** Framax wedge clamp
- D** Framax universal waling 0.90m
- E** Super plate 15.0 + Framax universal fixing bolt 10-25cm
- H** Tie rod system Framax Xlife plus 20.0
- I** Squared timber
- M** Framax Xlife plus panel 0.30m

Note:

On short walls (with high horizontal forces), shoring is required to restrain the formwork.

Wall step of 25 cm

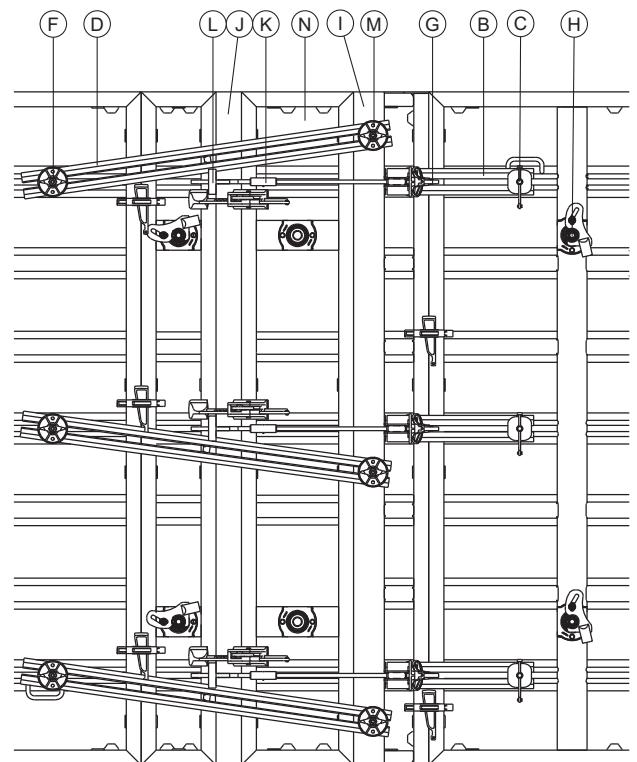
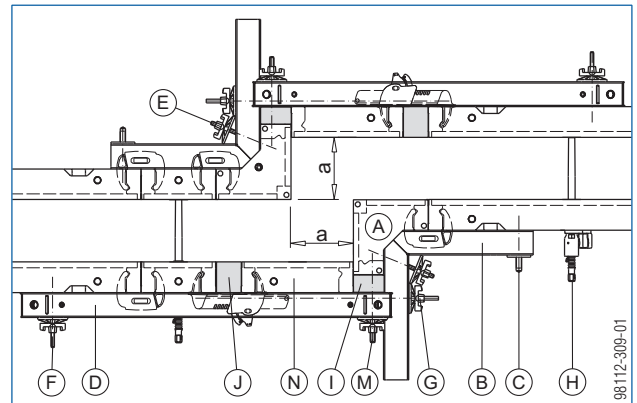

a ... 25 cm

- A** Framax Xlife plus inside corner 30/30cm or Framax Xlife inside corner
- B** Framax universal corner waling
- C** Framax wedge clamp
- D** Framax universal waling 1.50m
- E** Super plate 15.0 + Framax universal fixing bolt 10-25cm
- F** Super plate 15.0 + Framax universal fixing bolt 10-16cm
- G** Super plate 15.0 + Tie rod 15.0
- H** Tie rod system Framax Xlife plus 20.0
- I** Squared timber
- J** Framax fitting timber 10x12cm
- K** Rod connector 15.0
- L** Framax stop-end tie
- M** Super plate 15.0 + Star grip nut 15.0 G + Tie-rod 15.0mm ($L_{\min} = 0.40$ m)
- N** Framax Xlife plus panel 0.45m

Wall step from 10 to 45 cm

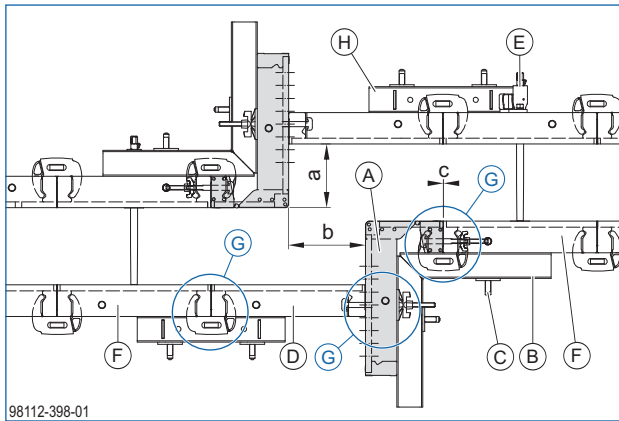

a ... 10 to 45 cm, in 5 cm increments

b ... max. 30 cm

c ... 0 cm (no closure permitted!)

A Framax Xlife pilaster panel right

B Framax universal corner waling

C Framax wedge clamp

D Framax Xlife plus panel **0.45m - 0.75m**

E Tie rod system Framax Xlife plus 20.0

F Framax Xlife plus panel **0.45m - 0.60m**

G Inter-panel connection (see the section headed [Inter-panel connections with wall step 10 - 45 cm](#))

Permitted fresh-concrete pressure: 60kN/m² (acting on whole area)

Inter-panel connections with wall step 10 - 45 cm

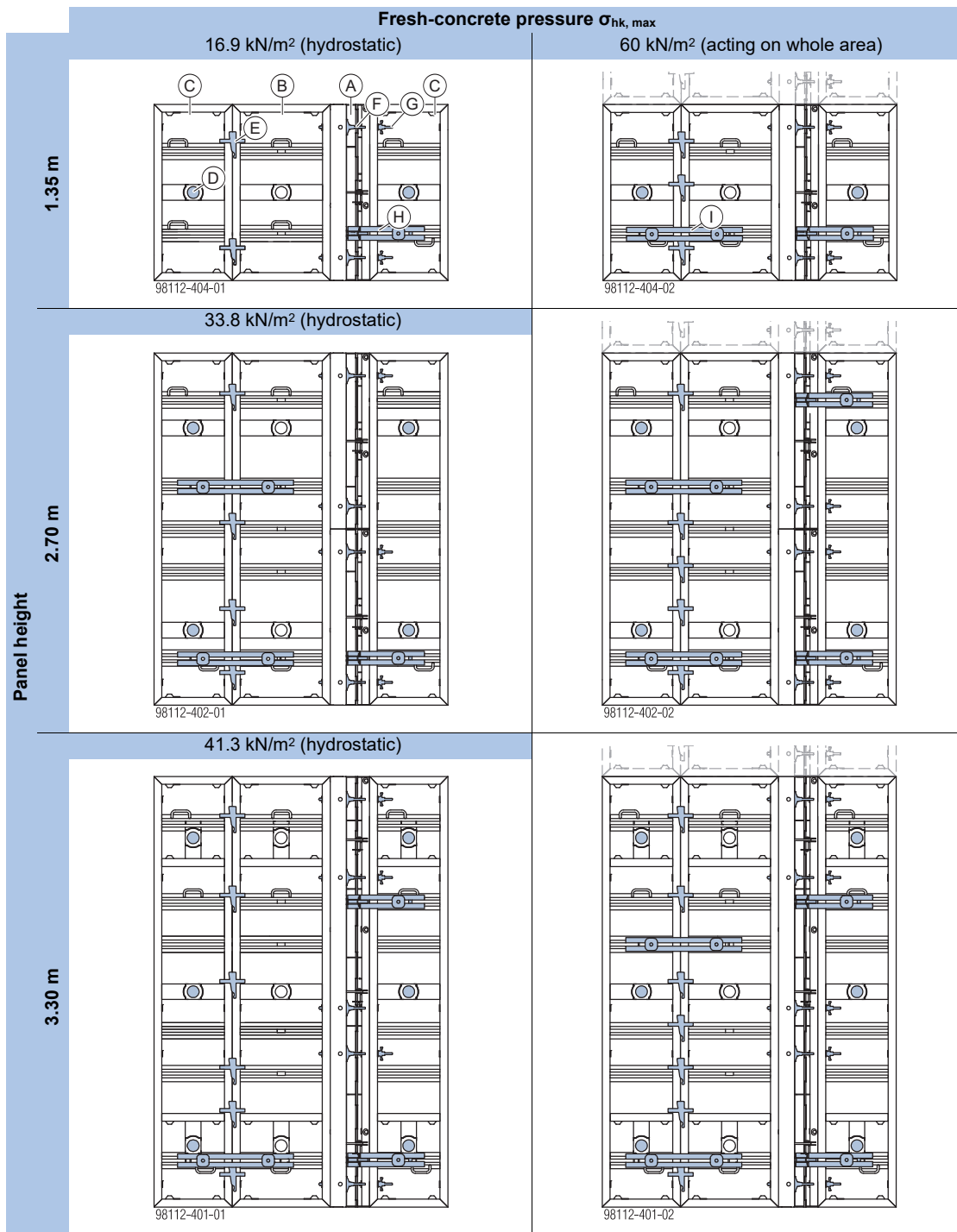

- A Framax Xlife pilaster panel right
- B Framax Xlife plus panel 0.45m - 0.75m
- C Framax Xlife plus panel 0.45m - 0.60m
- D Framax Xlife plus form tie 20.0
- E Framax quick acting clamp RU
- F Framax universal fixing bolt + Super plate 15.0
- G Framax universal fixing bolt + Star grip nut 15.0 G
- H Framax universal corner waling + 2 Framax wedge clamps
- I Framax universal waling + 2 Framax wedge clamps

Wall step from 35 to 90 cm

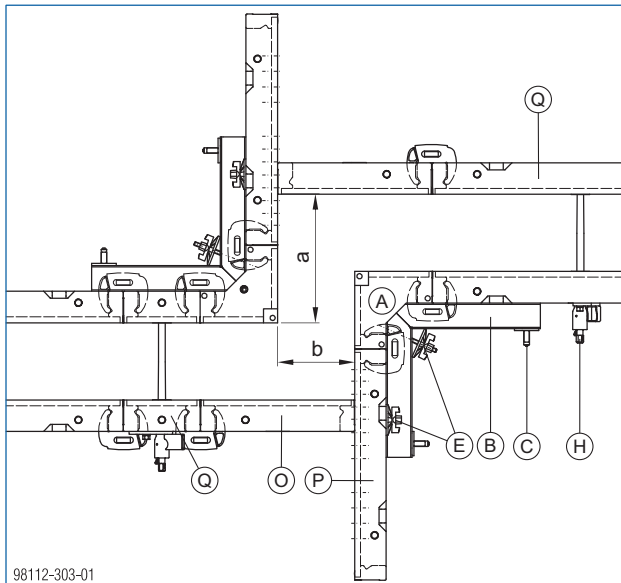

a ... 35 to 90 cm, in 5 cm increments
b ... 30 cm

- A** Framax Xlife plus inside corner 30/30cm or
Framax Xlife inside corner
- B** Framax universal corner waling
- C** Framax wedge clamp
- E** Super plate 15.0 + Framax universal fixing bolt
- H** Tie rod system Framax Xlife plus 20.0
- O** Framax Xlife plus panel 0.60m
- P** Framax Xlife universal panel 0.90m
- Q** Framax Xlife plus panel
(no 1.35m wide panel or 3.00m panel on its side!)

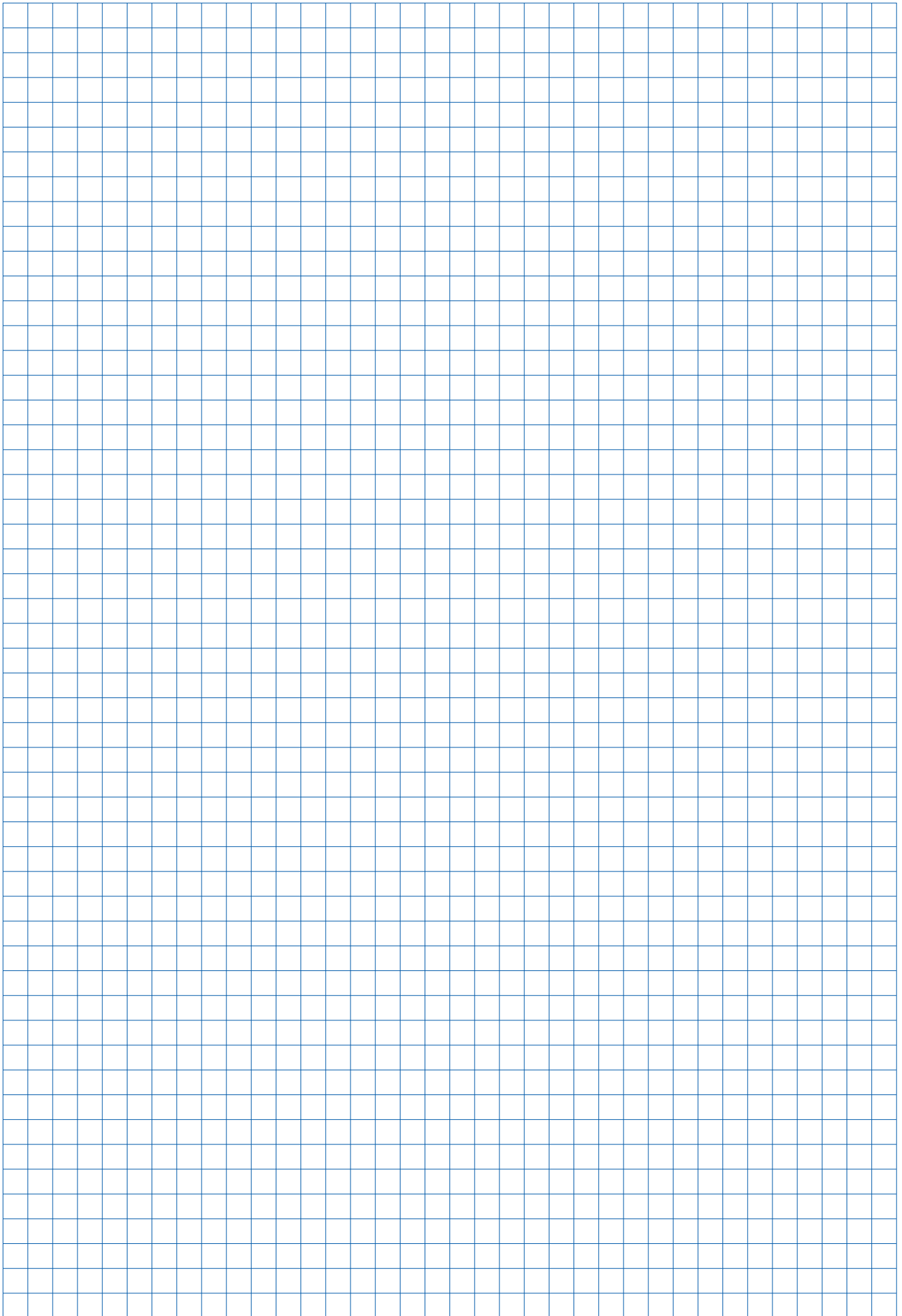

Wall thickness >45 and up to 60 cm

The following form ties are used for wall thicknesses > 45 and up to 60 cm:

- Framax Xlife plus form tie 20.0 45-60cm
- Framax head anchor 15-100cm

For more information, see section [Tie rod system Framax Xlife plus](#).

Note:

For wall thicknesses > 45 and up to 60 cm, the descriptions in this document apply with the following exceptions taken into account:

- Inter-panel connection near stop-end formwork
- Inter-panel connection near outside corner

Inter-panel connections for increased tensile loads:

- For each inter-panel joint up to 1.35 m
 - 2 additional clamps
- For each inter-panel joint between 1.35 m and 2.70 m
 - 1 additional clamp

Inter-panel connection near stop-end formwork

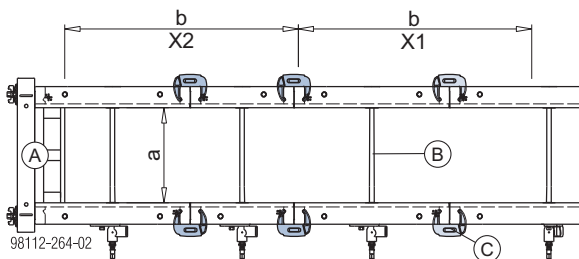

a ... wall thickness (> 45 and up to 60 cm)

b ... 1.35 m

X1 ... 1 additional clamp

X2 ... 2 additional clamps

A Stop-end formwork (see the section headed [Stop-end formwork](#))

B Framax Xlife plus form tie 20.0 45-60cm

C Framax quick acting clamp RU

Inter-panel connections near outside corners

Note:

For more information, see section [90 degree corners](#).



NOTICE

When forming walls in the thickness range > 45 and up to 60 cm, take the lower permissible fresh-concrete pressure in the corner area into account!

Permissible fresh-concrete pressure: 60 kN/m²

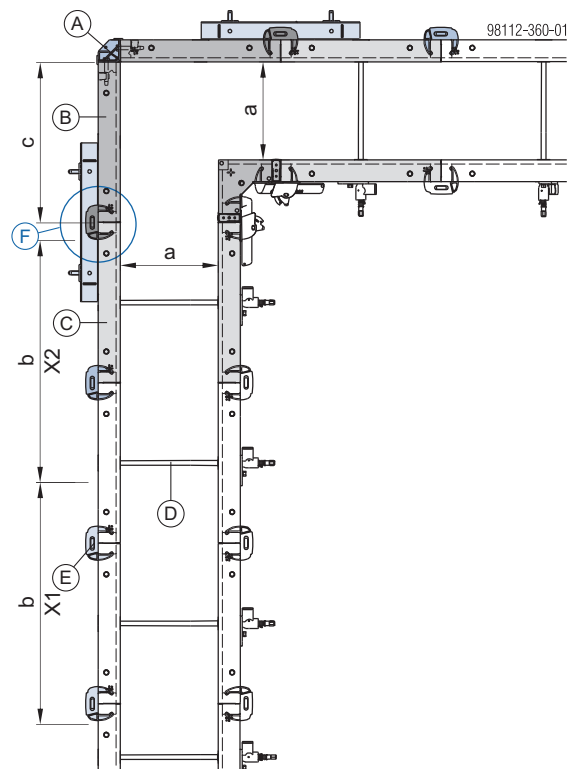

a ... wall thickness (> 45 and up to 60 cm)

b ... 1.35 m

X1 ... 1 additional clamp

X2 ... 2 additional clamps

c ... panel width 75 cm (a = 45 cm) or 90 cm (a = 45 - 60cm)

A Framax outside corner or Framax Xlife plus outs. corner 10/10cm

B Framax Xlife plus panel 0.75m / 0.90m

C Framax Xlife plus panel (no 1.35m wide panel or 3.00m panel on its side!)

D Framax Xlife plus form tie 20.0 45-60cm

E Framax quick acting clamp RU

F Inter-panel connection (see table 'Inter-panel connection, corner gangform with adjoining Framax Xlife plus panel')

Required number of connectors

Outside corner:

Height of outside corner	Quick acting clamp RU	Tensioning wedge + wedge bolt
0.60 m	2	2
1.35 m	—	4
2.70 m	—	8
3.00 m	—	8
3.30 m	—	10

Inter-panel connection, corner gangform with adjoining Framax Xlife plus panel:

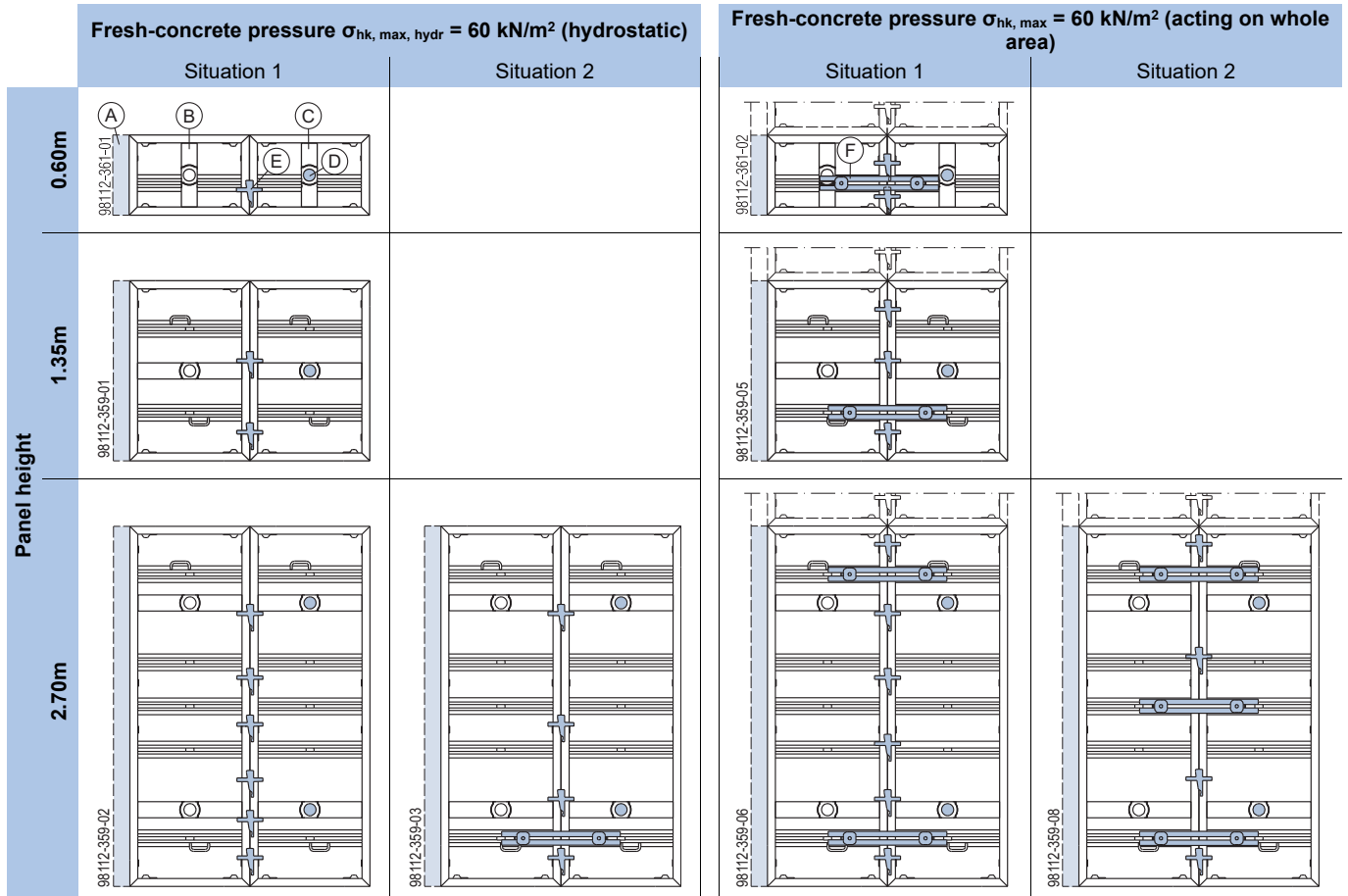

- A** Outside corner (Framax Xlife plus outs. corner 10/10cm / Framax outside corner; Inter-panel connection, see the section on the outside corner used)
- B** Framax Xlife plus panel **0.75m / 0.90m**
- C** Framax Xlife plus panel
(no 1.35m wide panel or 3.00m panel on its side!)
- D** Framax Xlife plus form tie 20.0 45-60cm
- E** Framax quick acting clamp RU
(or Framax multi function clamp for a closure)
- F** Framax universal waling + 2 Framax wedge clamps

Alternative with Quick acting clamp RU and universal fixing bolt (fresh-concrete pressure acting on whole area)

Panel height	Quick acting clamp RU	Universal fixing bolt + Star grip nut 15.0 G
0.60 m	1	1
1.35 m	3	2
2.70 m	5	3

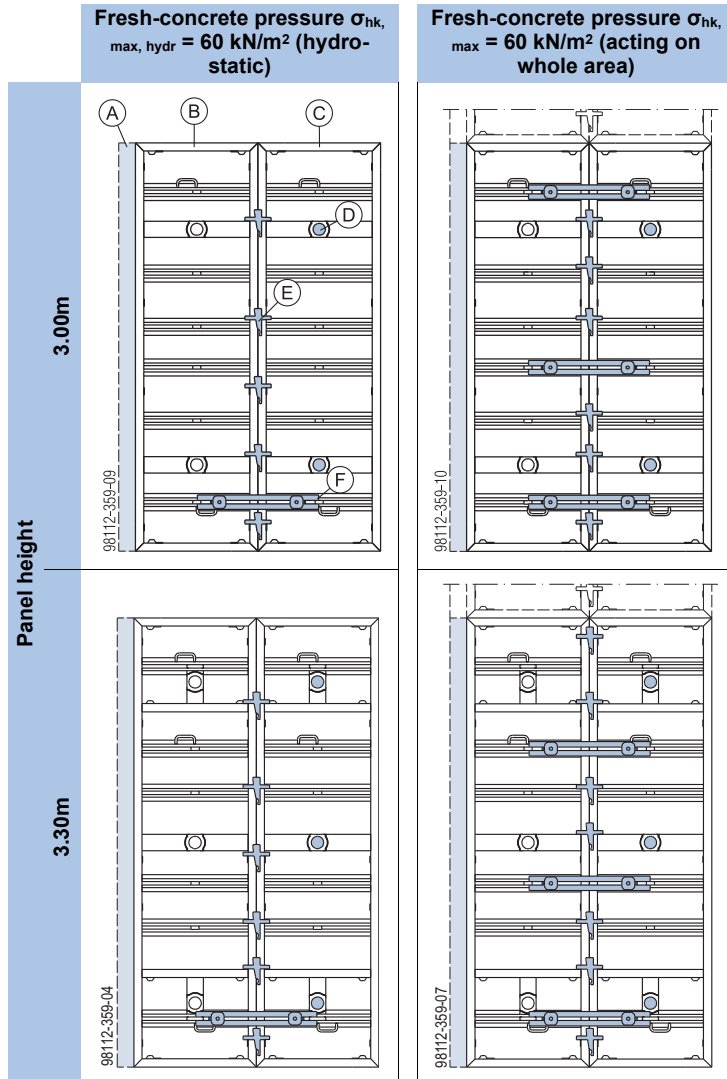

- A** Outside corner (Framax Xlife plus outs. corner 10/10cm / Framax outside corner; Inter-panel connection, see the section on the outside corner used)
- B** Framax Xlife plus panel 0.75m / 0.90m
- C** Framax Xlife plus panel
(no 1.35m wide panel or 3.00m panel on its side!)
- D** Framax Xlife plus form tie 20.0 45-60cm
- E** Framax quick acting clamp RU
(or Framax multi function clamp for a closure)
- F** Framax universal waling + 2 Framax wedge clamps

Alternative with Quick acting clamp RU and universal fixing bolt (fresh-concrete pressure acting on whole area)

Panel height	Quick acting clamp RU	Universal fixing bolt + Star grip nut 15.0 G
3.00 m	4	4
3.30 m	5	4

Window and door openings

Window and door box-outs can be formed quickly and stripped out non-destructively with **box-out clamps**. Planks are fixed in the box-out clamps by means of the integrated star grip nuts.

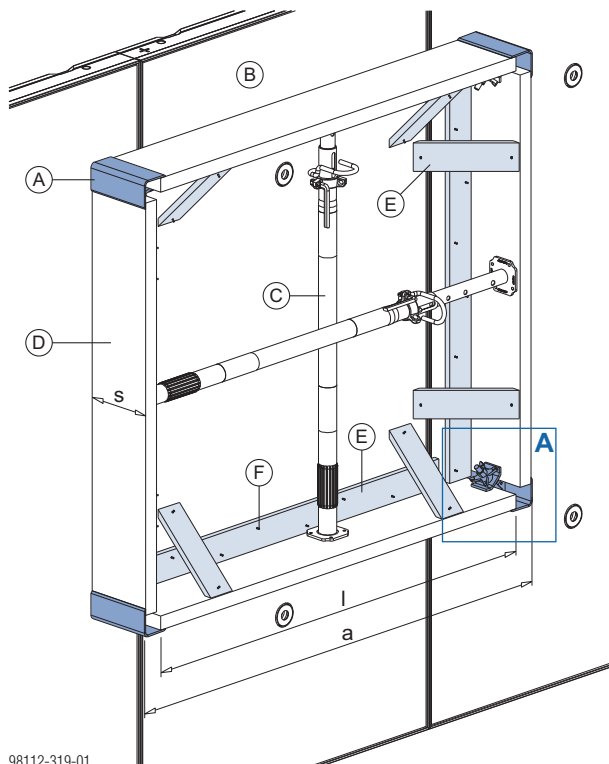

98112-319-01

Close-up A:

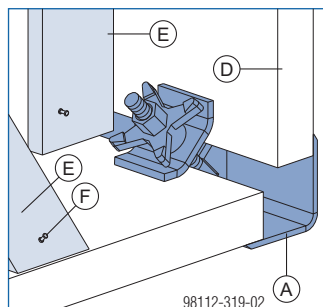

98112-319-02

a ... clear width of opening
l ... length of plank = a minus 12 cm
s ... plank width = wall thickness

- A Box-out clamp
- B Framax Xlife plus panel
- C Doka floor prop
- D Plank (wall thickness/2-5 cm)
- E Board (10/3 cm)
- F Double-headed nail

Assembly:

- ▶ Place the box-out clamps on the ground, fit boards into them and tighten the star grip nuts.
- ▶ Fasten the box-outs to the wall formwork with boards 10/3 cm and nails.
- ▶ Brace vertically and horizontally with suitable floor props (as statically required).

Plumbing accessories

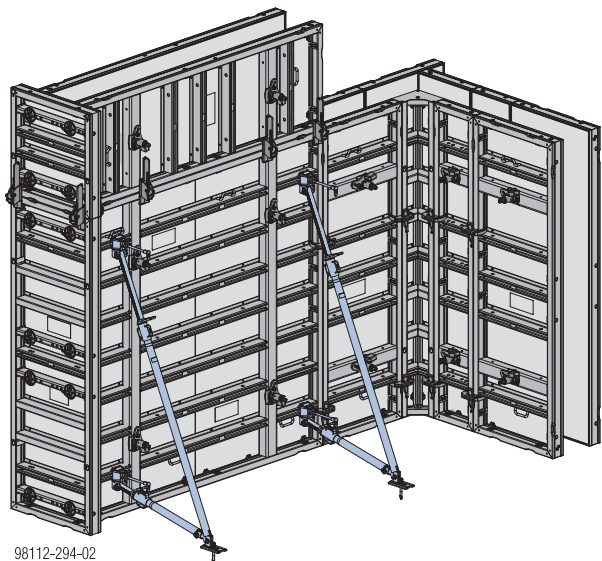

98112-294-02

Plumbing accessories brace the formwork against wind loads and make it easier to plumb and align the formwork.

- The values apply for a wind pressure of $w_e = 0.65 \text{ kN/m}^2$. This results in a peak velocity pressure of $q_p = 0.5 \text{ kN/m}^2$ (102 km/h) where $C_{p, net} = 1.3$. The greater wind loads encountered at exposed formwork-ends must be restrained by additional plumbing accessories (e.g. struts or pipe-braces). In cases where higher wind pressure is encountered, the number of struts must be determined by static calculation.
- Values apply for an angle α of the plumbing strut of 60° .
- Values do not apply for gang-forms in the edge zone or for free-standing gang-forms.
 - Gang-forms in the edge zone must be supported by at least 2 plumbing accessories.
 - Free-standing gang-forms must be supported by at least 2 plumbing accessories.



For more information, see the Calculation Guide 'Wind loads to the Eurocodes', or contact Doka!

Example: Where the formwork height is 7.20 m, the following are needed for every 5.40 m wide gang-form:

- 2 Panel struts 340
- 4 Panel struts 540



WARNING

Risk of the formwork tipping over!

- ▶ Ensure stability of the formwork panels in **every** phase of the construction work!
- ▶ Observe all applicable safety regulations!
- ▶ If **high wind speeds** are likely, or when work finishes for the day or before prolonged work-breaks, always take extra precautions to fix the formwork in place.

Suitable precautions:

- set up the opposing formwork
- place the formwork against a wall
- anchor the formwork to the ground (e.g. using Framax floor fixing plates)
- ▶ The safety pin is only for rough adjustment of the plumbing accessory. Do not attempt to remove or release the safety pin under load.



Universal dismantling tool

For easy operation of the spindle nuts.

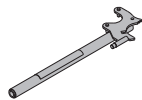

Number of struts per 2.70 m width of gang-form:

Formwork height [m]	Panel strut		Eurex 60 550
	340	540	
4.05	1 ^{*)}	—	—
5.40	—	1	—
6.00	1	1	—
7.20	1	2	—
8.10	—	1	1

Max. anchoring load:

$F_{exist} = 13.5 \text{ kN}$ (actual load)

$F_d = 20.3 \text{ kN}$ (design value incl. safety factors)

^{*)} Up to a height of 3.30 m, the spacing of the struts can be extended to 4.05 m apart.

Note:

Pre-assembly

- ▶ Install heads on the plumbing accessory.
- ▶ Fix the plumbing accessory to the formwork and to the ground (see connection possibilities below for details).
- ▶ Precision adjustment of the plumbing strut with adjusting nut.



- Safety pin (A) must be pushed all the way into the plumbing accessory and secured in position by the locking spring (B).
- Ensure functionality of the locking spring (B).

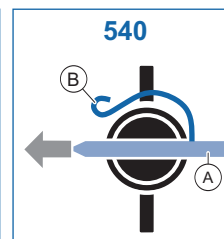
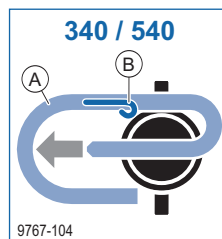

Fixing the struts to the formwork

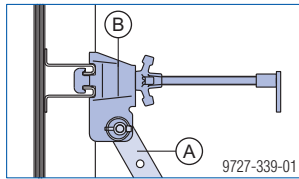

- A Panel strut 340 IB or 540 IB
- B Prop head EB

Animation: <https://player.vimeo.com/video/268536814>

Fixing to the ground

- ▶ Anchor the plumbing accessories in such a way as to resist tensile and compressive forces!

Drilled holes in footplate

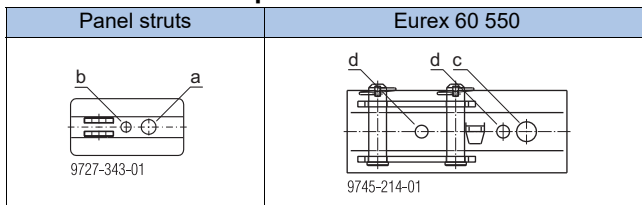

- a ... diam. 26 mm
- b ... diam. 18 mm (suitable for Doka express anchors)
- c ... diam. 28 mm
- d ... diam. 18 mm (suitable for Doka express anchors)

Anchoring the footplate

The **Doka express anchor** can be re-used many times over.

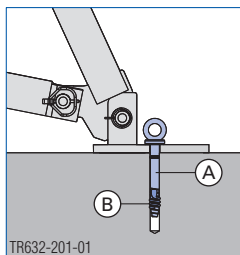

- A Doka express anchor 16x125mm
- B Doka coil 16mm

Doka express anchor 16x125mm:

Concrete strength class: min. C20/25

Cube compressive strength of the concrete during loading: $f_{ck,cube,current} = \text{min. } 15 \text{ N/mm}^2$ (corresponds to B15)



Follow the directions in the 'Doka express anchor 16x125mm' User Information booklet!

Required load-bearing capacity of alternative anchoring elements:

$R_d \geq 20.3 \text{ kN}$ ($R_k \geq 13.5 \text{ kN}$)

Follow the manufacturers' applicable fitting instructions.

Fixing the framed formwork panel to the ground

with floor fixing plates

The Framax floor fixing plate is used to fix and secure framed formwork panels:

- As safeguard against lift-out by the wind.
- When panel struts are used without adjusting struts (plumbing struts).

Example: Use with plumbing strut

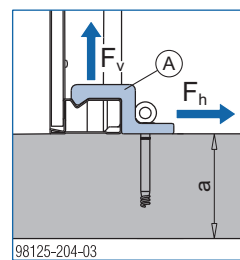

a ... min. 18 cm

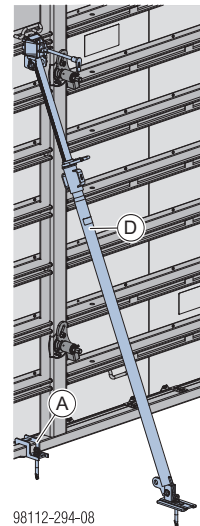

98112-294-08

Distance from edge to panel outside edge: min. 15 cm

- A Framax floor fixing plate
- D Plumbing strut 340 IB or 540 IB

Install a Framax floor fixing plate underneath each plumbing strut.

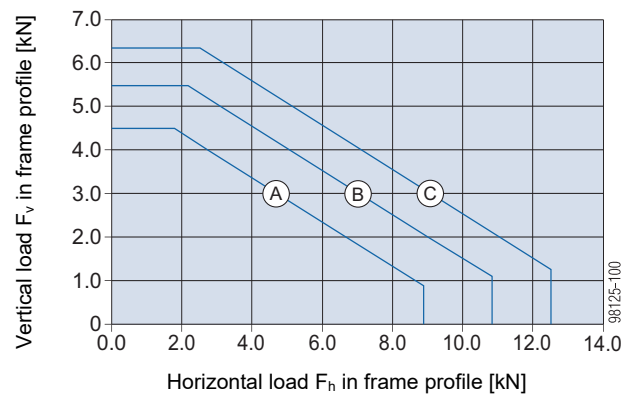

	Cube compressive strength $f_{ck,cube,current}$ of the foundation slab during loading	Max. anchoring load	
		F_{exist}	F_d
(A)	10 N/mm ² (corresponds to B10)	9.2 kN	13.8 kN
(B)	15 N/mm ² (corresponds to B15)	11.2 kN	16.8 kN
(C)	20 N/mm ² (corresponds to B20)	12.9 kN	19.4 kN

Panel struts

Product features:

- Can be extended in 8 cm increments
- Fine adjustment by screw-thread
- All parts are captive, including the inner tube which has a safety stop to prevent dropout

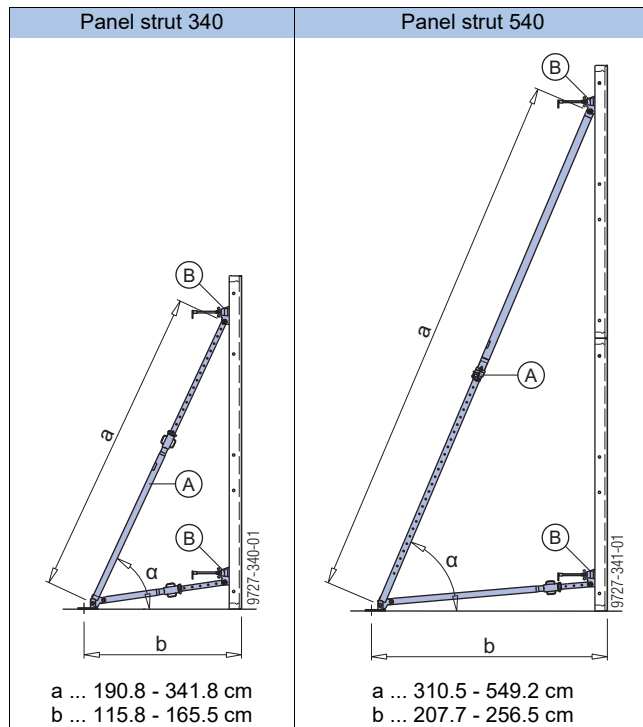

α ... approx. 60°

A Panel strut 340 IB or 540 IB

B Prop head EB

Eurex 60 550 used as a shoring & plumbing accessory

As the Doka plumbing strut Eurex 60 550 - fitted with the appropriate accessories - this prop can also be used for shoring high wall formwork.

- Can be connected directly – without modification – to Doka framed formwork and Doka timber-beam formwork
- The Adjusting strut 540 Eurex 60 IB makes handling much easier, especially when the formwork is being transferred.
- Can be telescoped in 10 cm increments, with continuous fine adjustment.



Follow the directions in the 'Eurex 60 550' User Information booklet!

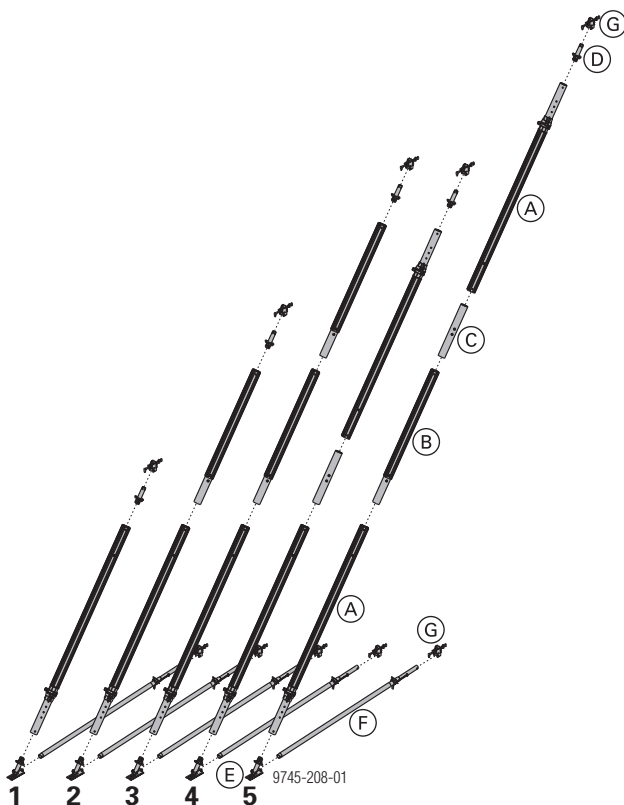

Example of a possible combination of type 2

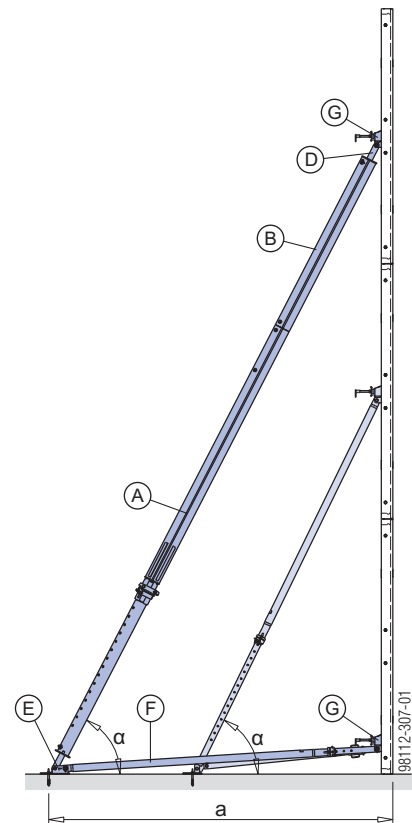

a ... 345.2 - 586.5 cm
 α ... approx. 60°

- A Plumbing strut Eurex 60 550
- B Extension Eurex 60 2.00m
- D Connector Eurex 60 IB
- E Plumbing strut shoe Eurex 60 EB
- F Adjusting strut 540 Eurex 60 IB
- G Prop head EB

The rule-of-thumb here is:

The length of the plumbing accessory (i.e. the complete Plumbing strut Eurex 60 550 assembly) = the height of the gang-form to be braced.

Type	Length extended L [m]	Plumbing strut Eurex 60 550 (A)	Extension Eurex 60 2.00m (B)	Coupler Eurex 60 (C)	Connector Eurex 60 IB (D)	Plumbing strut shoe Eurex 60 EB (E)	Adjusting strut 540 Eurex 60 IB (F)	Prop head EB (G)	Weight [kg]
1	3.79 - 5.89	1	—	—	1	1	1	2	91.1
2	5.79 - 7.89	1	1	—	1	1	1	2	112.4
3	7.79 - 9.89	1	2	—	1	1	1	2	133.7
4	7.22 - 11.42	2	—	1	1	1	1	2	142.5
5	9.22 - 13.42	2	1	1	1	1	1	2	163.8

Pouring platforms

can be quickly readied for use, and make concreting both easy and safe.

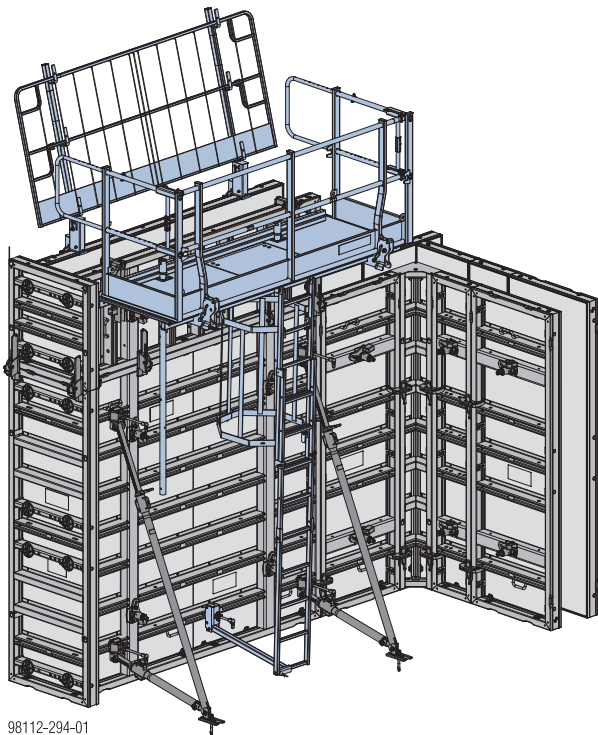

98112-294-01

Precondition for use:

- Observe all applicable safety regulations.
- Only fit pouring platforms to formwork structures of adequate stability ensuring that the expected loads can be taken.
- Ensure that the formwork gang is sufficiently rigid.
- Brace the formwork in a windproof manner when erecting it or when it is temporarily placed in the standing position.



NOTICE

If the formwork is lifted with the pouring platform still mounted to it, the platform must be secured so that it cannot slip to either side.

Xsafe plus platform

These pre-assembled, fold-out working platforms with their integral side railings, self-closing man-hole lids and integrable ladders are ready for immediate use and greatly improve workplace safety.

Note:

For detailed information on platform sizes, handling and accessories, see the 'Xsafe platform system plus' User Information booklet.

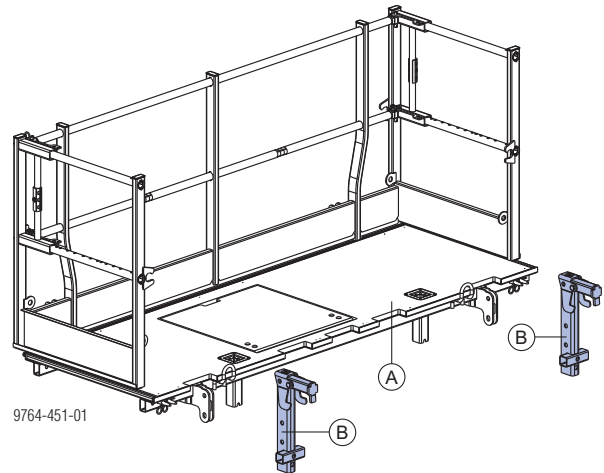

9764-451-01

A Xsafe plus platform

B Xsafe plus lifting adapter Framax (2 per platform)

Permitted service load: 1.5 kN/m² (150 kg/m²)

Load Class 2 to EN 12811-1:2003

Preconditions for using the Xsafe plus platform with the Xsafe plus lifting adapter Framax:

- max. one platform level
- max. vertical stacking configuration where the gang-form is assembled face-down on the ground and has a width of 2.70 m:

Basic panel (2.70m / 3.00m / 3.30m) + 1.35m

Mounting the lifting adapter onto the platform:

- Use Connecting pins 10cm and Spring cotters 5mm to mount the lifting adapter to the platform.

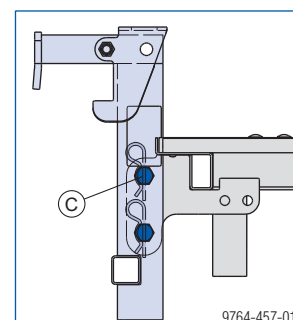

9764-457-01

C Connecting pin 10cm and Spring cotter 5mm of the Xsafe plus platform

Lifting the platform onto the formwork:

- ▶ Attach a 4-part lifting chain (e.g. Doka 4-part chain 3.20m) to the platform and hoist it towards the formwork.

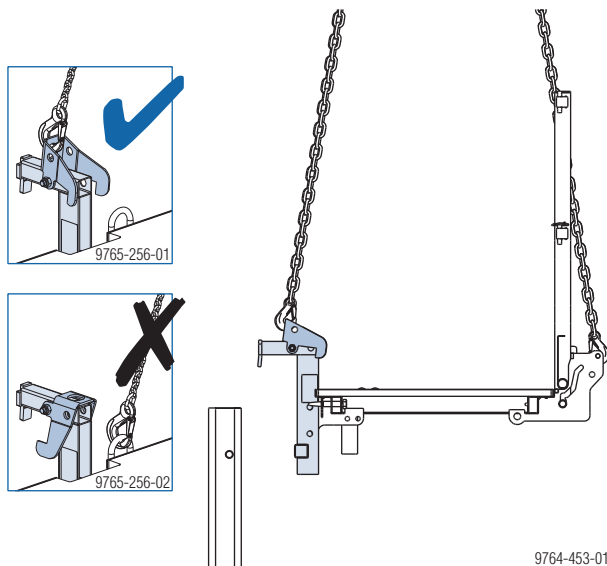

- ▶ Fix the platform to the top of the formwork.

Note:

On **horizontal panels**, mount the platform so that it is perfectly aligned with the panel (bearing profile of the lifting adapter is resting on the function profile of the panel).

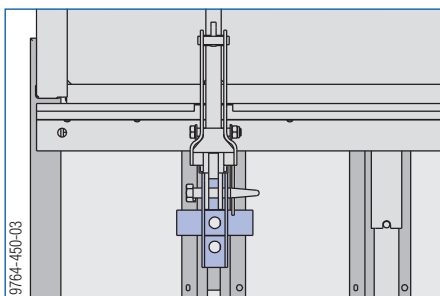

If under exceptional circumstances the platform is mounted at an offset to the outer edge of the panel, the bearing profile of the lifting adapter has to be widened.

- ▶ Push a hollow section into the bearing profile and secure it with a screw to prevent it dropping out.

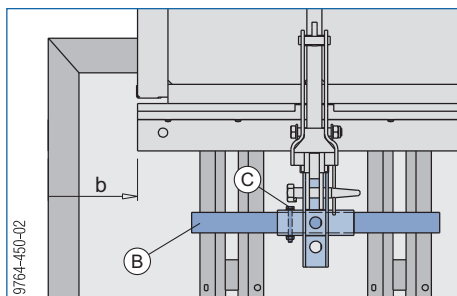

b ... offset

- B** Hollow section 40x40x2, L=550 mm, with diam. 10 mm borehole (site-provided)
- C** Hexagon bolt M8x65 + hexagon nut M8

Consequently, the bearing profile of the lifting adapter is resting on two function profiles of the panel.

- ▶ Detach the 4-part lifting chain. The securing hooks latch into place automatically.

 Do a sight-check to make sure that the securing hooks have latched into place!

The platform is now secured against accidental lift-out.

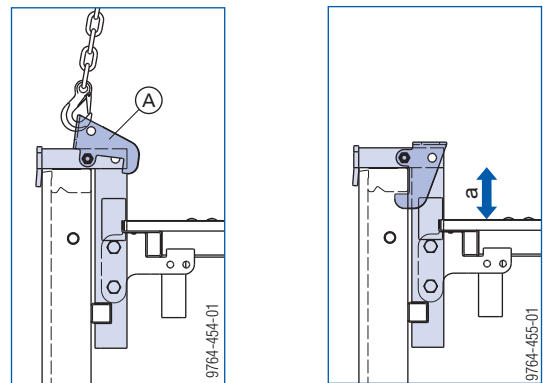

a ... 13 cm

A Securing hook

The level of the floor planking is 13 cm below the top edge of the formwork. This means that there is a 'boundary' on the side facing the formwork.

Lifting the platform off the formwork:

- ▶ Attach a four-part lifting chain to the platform and raise it. When the platform is raised by the four-part lifting chain on the safety hook, the platform is automatically unlocked.

Extending the platform to either side

The platform can be lengthened at either end by using the **Xsafe plus platform extension 0.60m**.



CAUTION

Platforms with platform extensions can tip up. Falling hazard!

- ▶ Do not step onto the **platform extension** until the safety hooks have been fixed in place.
- ▶ **Fix the safety hooks** of both lifting adapters with Framax universal fixing bolts and Super plates 15.0.

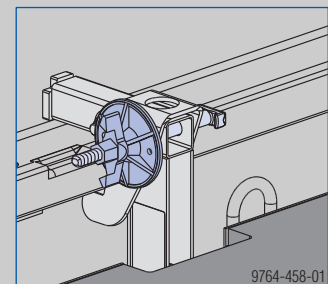

Xsafe plus telescopic ladder

Telescoping the ladder:

- ▶ Extend the Xsafe plus telescopic ladder or Xsafe aluminium telescopic ladder 1.55-2.70m to the required length and secure it with hinged pins (insert from outside to inside).

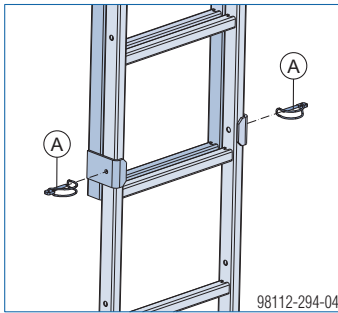

A Hinged pin (included in the scope of supply of the ladder)



- Check that the hinged pin is inserted the right way round!
- The clip of each hinged pin must be closed!

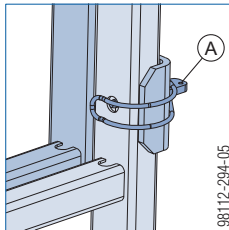

Connection to the Xsafe plus platform:

- ▶ Hook the telescopic ladder into the integrated ladder connection.
- ▶ Secure with Spring cotters 5mm.

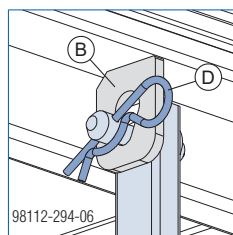
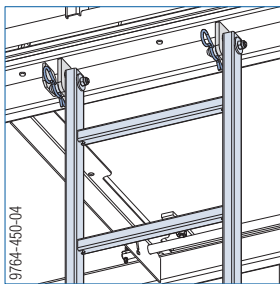

B Integrated ladder connection on the Xsafe plus platform

D Spring cotter 5mm



- The groove in the ladder pin (**C**) must be engaged in the hole of the ladder connection (**B**) !
- The ladder must be secured with Spring cotters 5mm (**D**) !

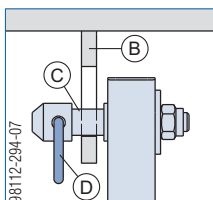

Connection to the formwork:

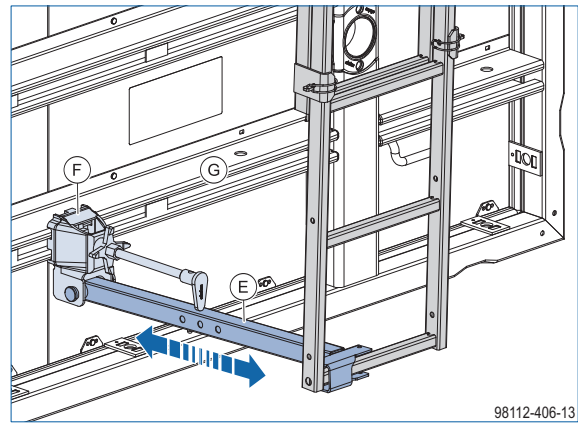

E Xsafe universal ladder holder

F Prop head EB

G Function profile of the Framax Xlife plus panel

Moving the formwork and the platform in one piece

The **Framax lifting hook** makes it possible to reposition or raise the formwork and Xsafe plus platform upright in one piece.



CAUTION

Use for raising upright or laying down formwork with basic panel height 2.70m, 3.00m or 3.30m with a vertical stacking > 1.35m is not permitted!

- ▶ In these cases, remove the platform before raising upright / laying down the formwork.

Repositioning:

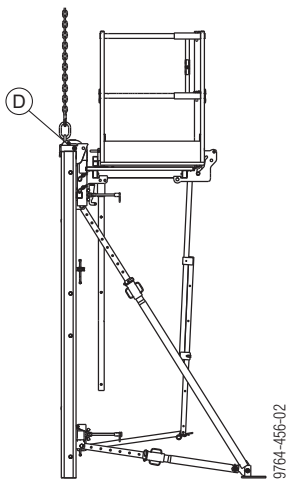

Raising upright / laying down:

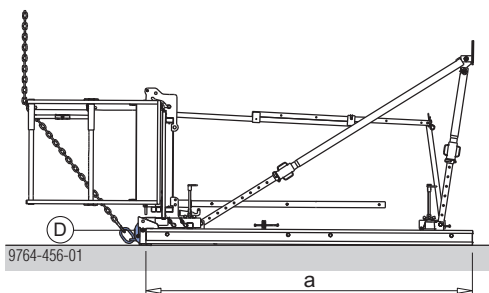

a ... Basic panel (2.70m / 3.00m / 3.30m) + 1.35m max.

D Framax lifting hook

Framax pouring platform U 1.25/2.70m

A pre-assembled, foldable, ready-to-use platform, 1.25 m wide, for convenient and safe working.

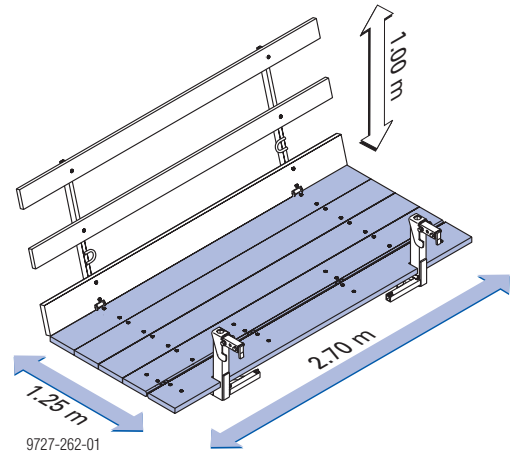

Permitted service load: 1.5 kN/m² (150 kg/m²)

Load Class 2 to EN 12811-1:2003



NOTICE

- It is not permissible to lay the formwork down flat together with the pouring platform!
- Planks can be used to bridge decking-to-decking gaps up to 50 cm for length adaptation. Minimum plank overlap 25 cm.
- The pouring platform cannot be installed if **Framax Xlife plus panels 0.60m** are used at the top for vertical stacking.
 - Use Framax Xlife plus panels 0.60m at the bottom for vertical stacking.



Other possible areas of use for the Framax pouring platform U:

- Framed formwork Framax Xlife
 - Framed formwork Alu-Framax Xlife
 - Large-area formwork Top 50 (with Top50 adapter for Framax pouring platform U)
 - Wall formwork FF20 (with FF20 adapter for Framax pouring platform U)
- The level of the floor planking is 30 cm below the top edge of the formwork. This means that there is a 'boundary' on the side facing the formwork.
 - The guard rail can be locked in either of two positions:
 - vertical
 - tilted by 15°
 - Tilt-back board:
 - The front deck-board can be tilted back so that panel struts can be attached to the panel.
 - This lets you get at form ties at the top of the formwork, and makes room for any projecting universal walings.

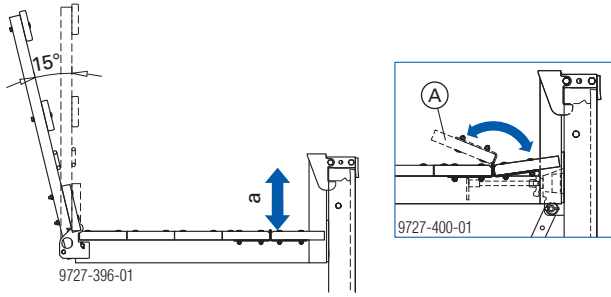

a ... 30 cm

A Tilt-back board

Preparing the pouring platform:

- ▶ Tilt up the guard rails and lock them in position.

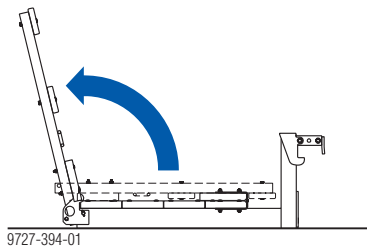

- ▶ Put both side stops into position.

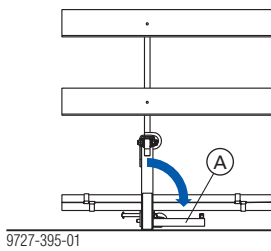

A Side stop

- ▶ Close the decking with the tilt-back board.

Lifting the platform onto the formwork:

- ▶ Attach a four-part lifting chain (e.g. Doka 4-part chain 3.20m) to the pouring platform and hoist it towards the formwork.

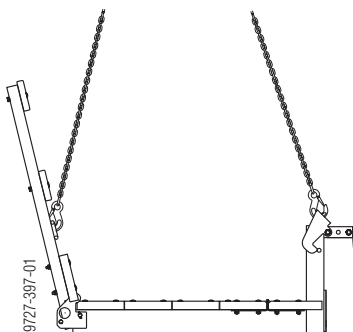

- ▶ Fix the pouring platform to the top of the formwork.

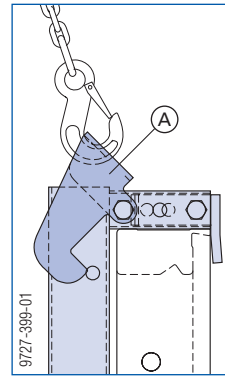

A Safety hook

- ▶ Detach the four-part lifting chain. The safety hooks latch into place automatically.



Do a sight check to make sure that the safety hooks have latched into place!

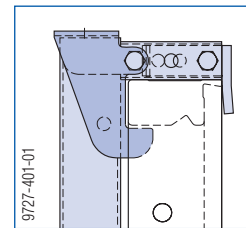

The pouring platform is now secured against accidental lift-out.

Lifting the platform off the formwork:

- ▶ Attach a four-part lifting chain to the pouring platform and raise it. When the pouring platform is raised by the four-part lifting chain on the safety hook, the platform is automatically unlocked.

Transporting, stacking and storing

Stack of 10 Framax pouring platforms U

Single collapsed platform

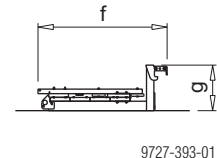
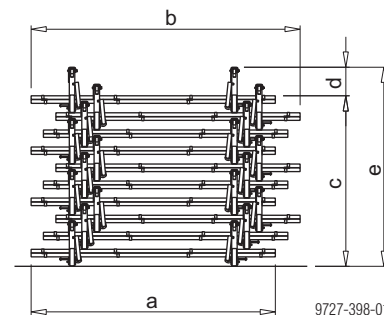

- a ... 268 cm
- b ... 295 cm
- c... 10 x 18.7 cm
- d... 31 cm
- e... approx. 218 cm
- f... 142 cm
- g... 50 cm

Moving the formwork and the platform in one piece

The **Framax lifting hook** allows the formwork to be repositioned together with the pouring platform.



NOTICE

It is not permissible to set up or lay the formwork down flat together with the pouring platform!

Sideguards on exposed platform-ends

On pouring platforms that do not completely encircle the structure, suitable sideguards must be placed across exposed end-of-platform zones.

Note:

The plank and board thicknesses stated comply with the EN 338 C24 timber.

Observe all national regulations applying to deck and guardrail boards.

Side handrail clamping unit T

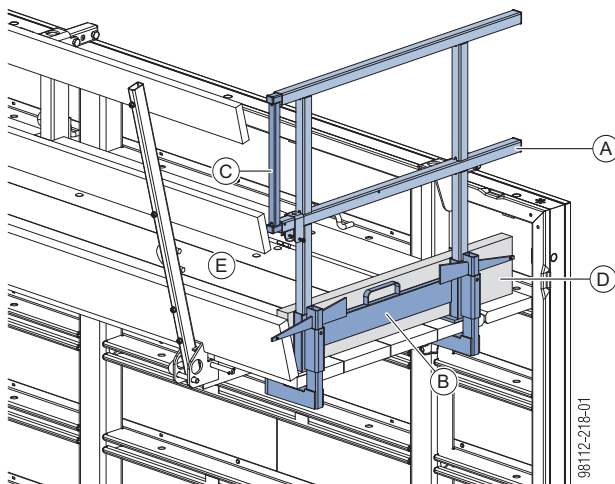

- A Side handrail clamping unit T
- B Clamping part
- C Integrated telescopic railing
- D Guardrail board min. 15/3 cm (site-provided)
- E Pouring platform

Installation:

- ▶ Use the wedge (clamping range 4 to 6 cm) to fasten the clamping part to the decking of the pouring platform.
- ▶ Slot in the railing.
- ▶ Extend the telescopic railing to the desired length and secure it.
- ▶ Insert toeboard (guardrail board).

Pouring platforms with single brackets

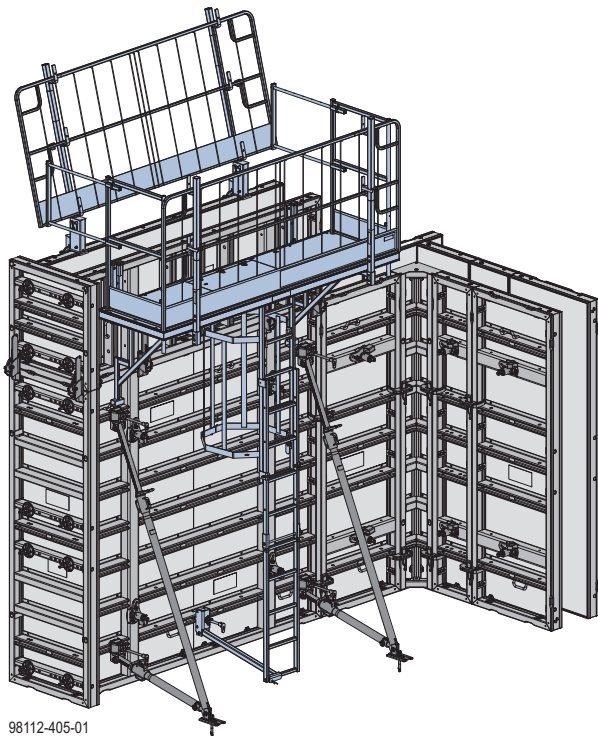

Precondition for use:

- Observe all applicable safety regulations.
- Only fit pouring platforms to formwork structures of adequate stability ensuring that the expected loads can be taken.
- Ensure that the formwork gang is sufficiently rigid.
- Brace the formwork in a windproof manner when erecting it or when it is temporarily placed in the standing position.

Xsafe bracket system

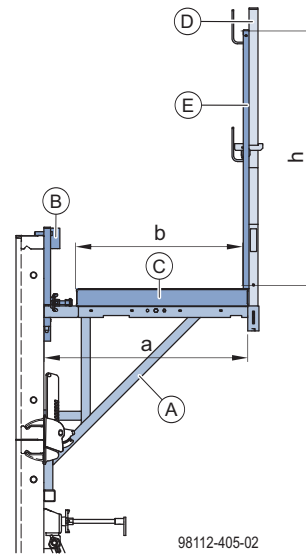

a ... 90 cm
b ... 75 cm
h ... 114 cm

- A** Bracket XBS 90 EP
- B** Framax adapter XBS
- C** Deck XBS
- D** Handrail post XBS 1.40m
- E** Protective grating XP 1.20m

Permitted service load: 1.5 kN/m² (150 kg/m²)

Load Class 2 to EN 12811-1:2003

Max. influence width: 2.00 m

Framax adapter XBS

The Framax adapter XBS is used to install the Bracket XBS 90 EP on the Framax Xlife plus panel.

The movable clamping bolt allows the adapter to be adjusted flexibly to the respective position of the function profile.



NOTICE

The bearing surface of the adapter must fit flush with the frame or cross profile.

Possible fixing options

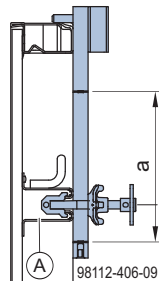

a ... Adjusting range 28 cm

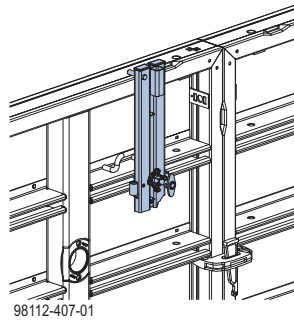

Panel upright

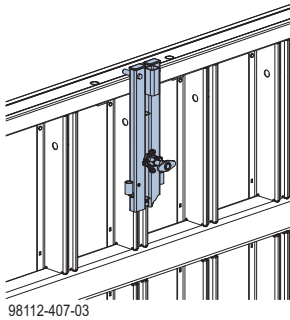

Panel on its side

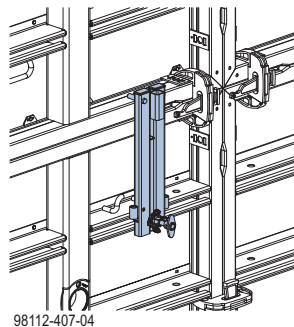

Inter-panel joint

Deck XBS 75

Deck XBS 75

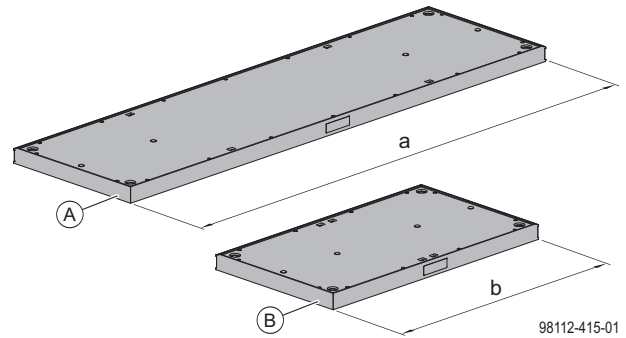

a ... 267.5 cm
b ... 132.5 cm

A Deck or Hatch deck XBS 75/270cm

B Deck XBS 75/135cm

Note:

The toothed strip engages in the securing hook of the bracket and serves to prevent the deck from tipping.

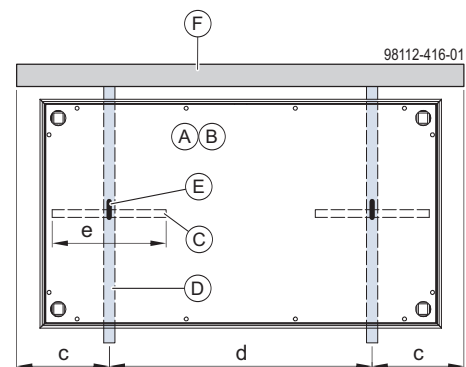

View from above

Deck XBS 75/270cm (A)	Deck XBS 75/135cm (B)
c... 11 to 50 cm	11 to 38 cm
d... 170 to 248 cm	59 to 113 cm
e... 39 cm	27 cm

C Toothed strip of the deck XBS

D Bracket XBS

E Securing hook of the bracket XBS

F Formwork panel or gang-form
(schematic diagram)

Erection sequence



NOTICE

- For working at heights that cannot be reached from the floor, use a suitable elevated platform (e.g. Platform stairway 0.97m, Wheel-around scaffold DF or mobile scaffold tower)!
- Always comply with the country-specific safety regulations!
- Do not step on to the pouring platform until an all-round guardrail system (including counter railing) is in place!
Otherwise wear a personal fall-arrest system (e.g. safety harness)!

Note:

For details of the procedures for setting up and stripping the formwork, see the sections headed [Instructions for assembly and use for room-high formwork](#) and [Instructions for assembly and use for high formwork](#).

Horizontal assembly

- ▶ Pre-assemble the gang-form face-down on a prepared flat area (see the section headed [Inter-panel connections](#)).
- ▶ Attach the Tie-off set PPE type A for the personal fall-arrest system to the frame profile or function profile.

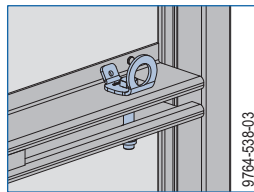
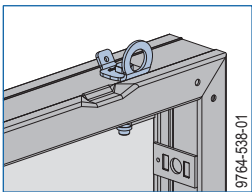

- ▶ Install the Framax adapter XBS on the gang-form while it is laid flat.

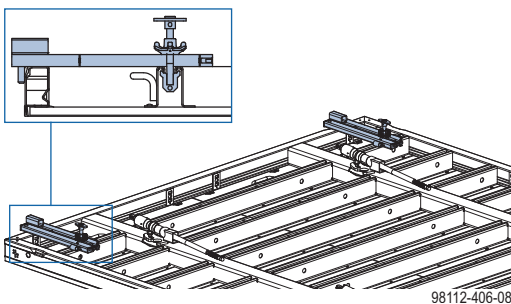

Check whether the bearing surface of the adapter is flush with the frame or cross profile.

- ▶ Hook the Bracket XBS 90 EP into the adapter. The bracket is hooked in correctly when the indicator on the adapter shows green.

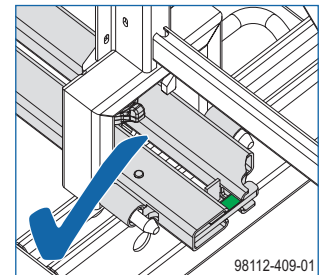
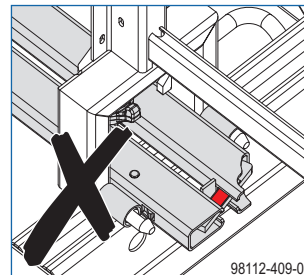
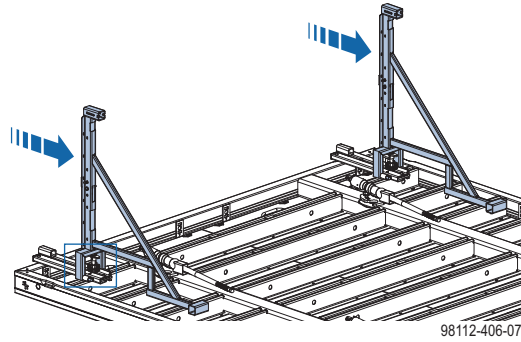

- ▶ Ensure that the securing hook of the bracket is in its operational position. Otherwise remove the safety pin (A), fold up the securing hook, insert the safety pin again and secure the safety pin (A) with a linch pin.

Parking position for wooden planks

Operational position for deck XBS

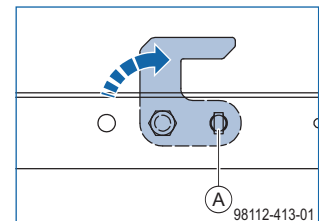
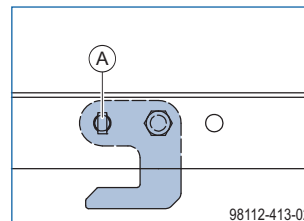

Wooden planks can also be used as platform decking instead of the deck XBS.

The wooden planks are secured from below using wood screws.

In this case the securing hook remains in parking position.

**NOTICE**

- ▶ Observe the installation direction for Hatch deck XBS 75/270cm! The hinges of the manhole lid must be on the formwork side.

- ▶ Push deck XBS onto the brackets. The securing hooks of the brackets must engage in the two toothed strips of the deck.

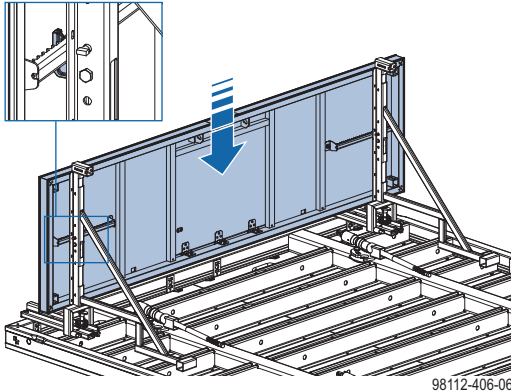

Do a sight-check to ensure that both brackets are hooked into the toothed strips to prevent slipping or tipping.

- ▶ Attach Handrail posts XBS 1.40m until the lock engages ('Easy-Click' function) and push the anti-lift-out guard of the handrail posts upwards.

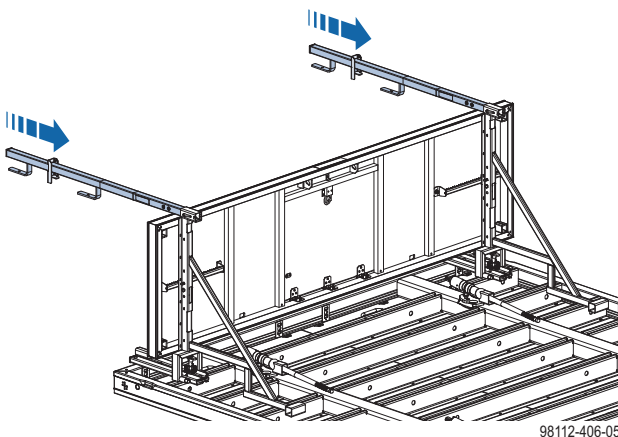

When the handrail posts have been installed, the decking is secured against being lifted out.

- ▶ Hook in protective grating XP and push the anti-lift-out guard down again. Before installing the protective grating, observe the notices in the section headed [Lifting the formwork and Xsafe bracket system in one piece!](#)

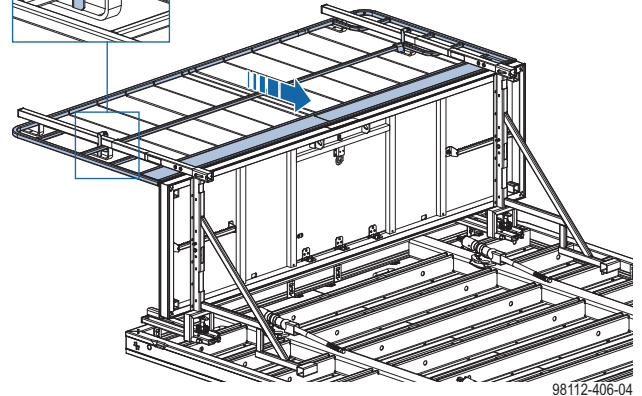
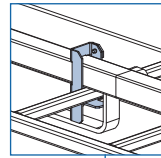

- ▶ Install panel struts (see the section headed [Plumbing accessories](#)).
- ▶ With Hatch deck XBS 75/270cm, install Xsafe plus telescopic ladder (see the section headed [Xsafe plus telescopic ladder](#)).
- ▶ Place suitable sideguards across exposed end-of-platform zones on pouring platforms that do not completely encircle the structure (see the section headed [Sideguards on exposed platform-ends](#)).
- ▶ Lift the gang-form to its new location (see the section headed [Lifting the formwork and Xsafe bracket system in one piece](#)).
- ▶ Spray the formwork sheet with release agent (see the section headed [Cleaning and care of your equipment](#)).
- ▶ Fix the panel struts to the ground stably.

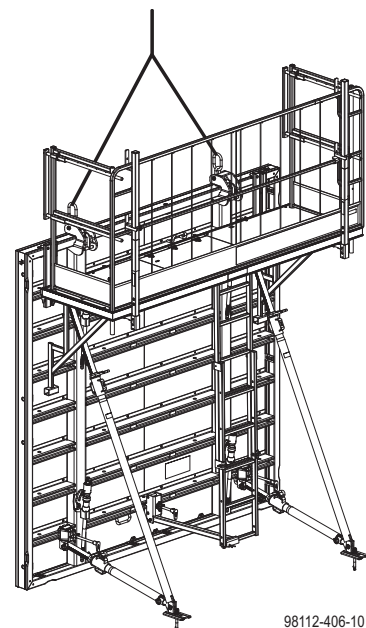

The gang-form is now stable and can be plumbed and aligned exactly, with no need for the crane.

**WARNING**

No all-round guardrail system present on the pouring platform!

Danger to life from fatal falls!

- ▶ Use a personal fall-arrest system (e.g. safety harness)
The Tie-off set PPE type A (A) connected to the framed formwork panel serves as attachment point.

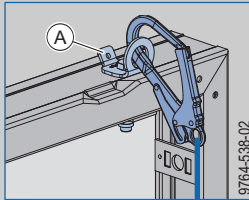

- ▶ Detach the gang-form from the crane.
- Dismantling is the reverse of the assembly procedure.

Assembling in the upright

- ▶ Pre-assemble the gang-form face-down on a prepared flat area (see the section headed [Inter-panel connections](#)).
- ▶ Mount panel struts to the gang-form while it is laid flat (see the section headed [Plumbing accessories](#)).

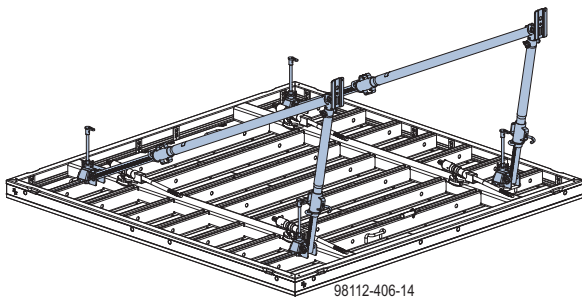

- ▶ Raise the gang-form by crane.
- ▶ Spray the formwork sheet with release agent (see the section headed [Cleaning and care of your equipment](#)).
- ▶ Lift the gang-form to its new location.
- ▶ Fix the panel struts to the ground stably.
The gang-form is now stable and can be plumbed and aligned exactly, with no need for the crane.
- ▶ Use the Framax assembling tool to disengage the Framax lifting hooks from the gang-form (see the section headed [Lifting by crane](#)).

Mounting the pouring platform:

The pouring platform is installed from an elevated platform (e.g. Wheel-around scaffold DF).

**NOTICE**

- ▶ If the formwork height is 3.30m, install the brackets in the second function profile from the top to ensure reachability for installation from the elevated platform.
- ▶ Install the pouring platform from the elevated platform. (Installation steps and details, see the section headed [Horizontal assembly](#)).

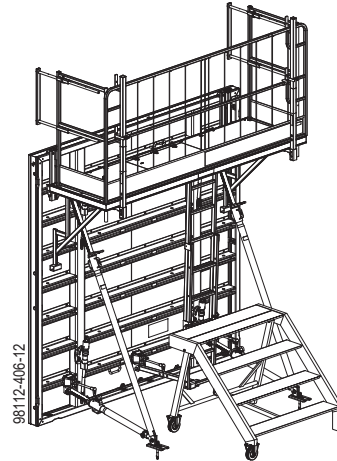

Dismantling is the reverse of the assembly procedure.

Lifting the formwork and Xsafe bracket system in one piece

The **Framax lifting hook** allows the formwork to be raised, repositioned and laid down for cleaning together with the Xsafe bracket system (see the section headed [Lifting by crane](#)).



Before repositioning, ensure that the decking is secured with the two securing hooks and handrail posts.



CAUTION

➤ Raising upright / laying down with installed edge protection and laying down for cleaning is only permitted up to a formwork weight of 760 kg (corresponding to basic panel height 2.70m, 3.00m or 3.30m with a vertical stacking of max. 1.35m).

Raising upright / laying down:

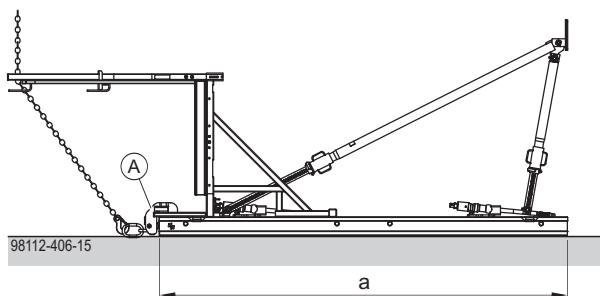

NOTICE

With a formwork weight of > 760 kg, remove the edge protection before raising upright / laying down!

Laying down for cleaning:

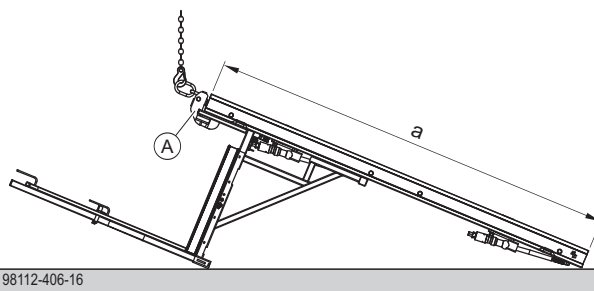

a ... basic panel (2.70m / 3.00m / 3.30m) + 1.35m max.

A Framax lifting hook



NOTICE

- Laying down for cleaning is permitted only with max. one deck level!
- Before laying down for cleaning, remove the panel struts (and fold down or remove the telescopic ladder, if applicable)!

Gap Filler Plank

The infill deck XBS allows deck openings in the Xsafe bracket system from 0.30 to 1.35 m to be bridged.

The infill deck XBS can be used in the straight wall or in inside corners (see the section headed [Inside corners](#)).

Note:

The infill deck is secured on one side and rests free on the other side.

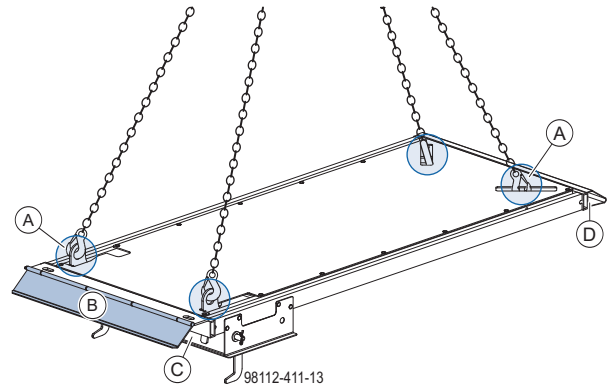

A Crane lifting point

B Deck hatch

C Secured side

D Resting side

Secured side with securing housing in detail

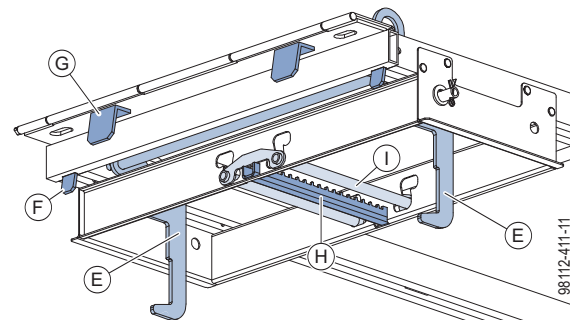

View from below

E Securing element

F Suspension plate for hooking into deck XBS

G Suspension plate for hooking into infill deck XBS

H Toothed strip for securing the position

I Anti-slip guard



NOTICE

- The infill deck must have at least 25 cm contact on the resting side.
- Sufficient contact is assured if the crane attachment openings (**J**) are completely covered by the deck below.

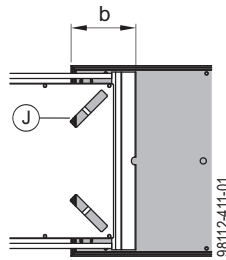

b ... min. 25 cm

Closure in the straight wall

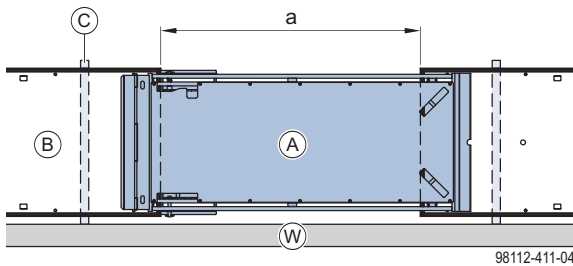

a ... 0.30m - 1.35m

- A** Infill deck XBS
- B** Deck XBS
- C** Bracket XBS
- W** Gang-form (schematic diagram)

Installation:

First install the standard XBS decks and secure with handrail post, only then install the infill deck.

- Push the securing element towards the frame (**1**) and swing up (**2**).

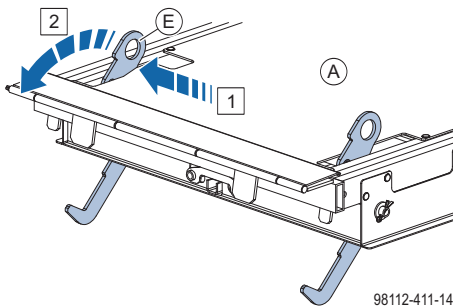

- A** Infill deck XBS
- E** Securing element

- Lift the infill deck to its intended location.

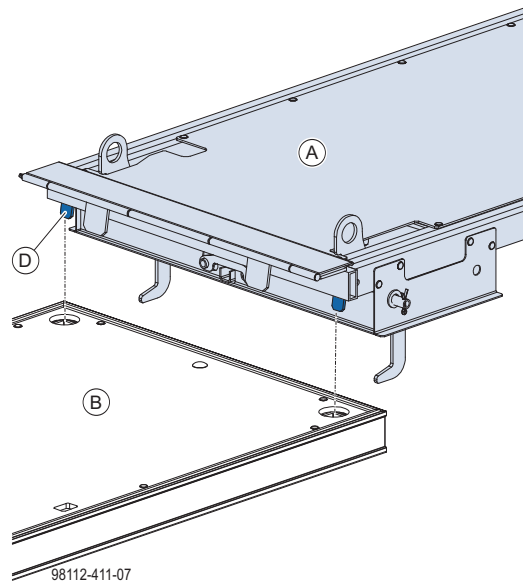

- A** Infill deck XBS
- B** Deck XBS
- D** Suspension plate for hooking into deck XBS

Suspension plates engage in the recesses in the deck XBS.

- Swing the securing element on the crane lifting point down.

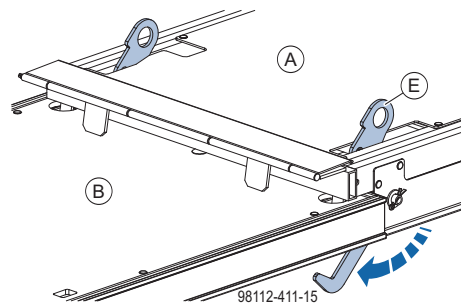

- Close the deck hatch.

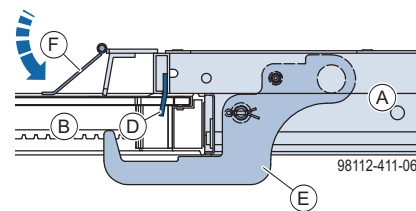

- A** Infill deck XBS
- B** Deck XBS
- D** Suspension plate for hooking into deck XBS
- E** Securing element
- F** Deck hatch



Do a sight-check to ensure that the securing element is closed.

- Install Protective grating XP 1.20m.

Inside corners

Note:

- The brackets XBS and decks XBS can be installed on the gang-form while it is laid flat!
- Installation of infill deck XBS is only possible on the upright gang-form after installation of the brackets XBS and decks XBS!
- See the section headed [Erection sequence!](#)

Inside corner with standard XBS decks

2 decks XBS

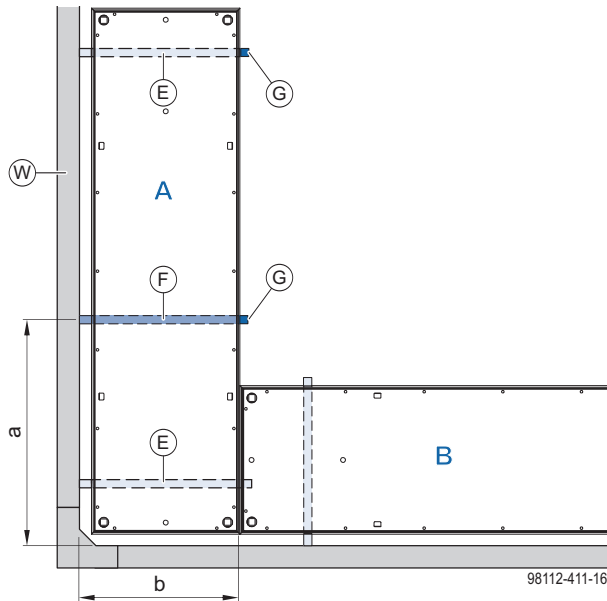

a ... from inside corner to additional bracket XBS: 0.93 m - 1.53 m
b ... 0.92 m

- A Deck A - Deck XBS**
- B Deck B - Deck XBS**
- E Bracket XBS**
- F Bracket XBS (additionally required)**
- G Handrail post XBS 1.40m**
- W Gang-form (schematic diagram)**



NOTICE

When installing **deck A**, note:

- Install the first bracket XBS as far in the corner as possible (immediately next to the inter-panel connections of the inside corner)!
- An additional bracket XBS with handrail post XBS is required for installation of the edge protection!

Inside corner with closure on one side

1 deck XBS / 1 infill deck XBS

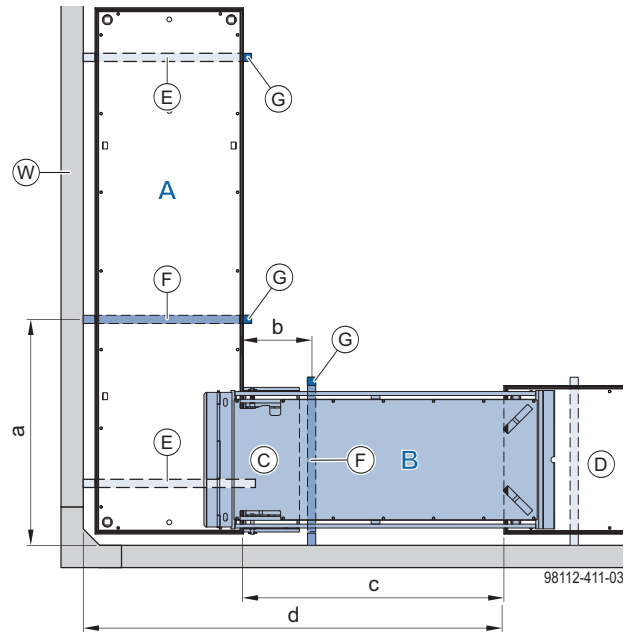

a ... from inside corner to additional bracket XBS: 0.93 m - 1.53 m
b ... from deck A to additional bracket XBS: 0.35 m - 0.60 m
c ... 0.30 m - 1.35 m
d ... 1.20 m - 2.25 m

- A Deck A - Deck XBS**
- B Deck B - Infill deck XBS**
- C Securing housing of infill deck XBS**
- D Deck XBS (standard deck)**
- E Bracket XBS**
- F Bracket XBS (additionally required)**
- G Handrail post XBS 1.40m**
- W Gang-form (schematic diagram)**

Installation sequence:

1. **Standard XBS deck (D)**
2. **Deck A (A)**
(see section [Inside corner with standard XBS decks](#))
3. **Deck B (B)**

Installation of deck B:



NOTICE

- ▶ An additional bracket XBS with handrail post XBS is required for installation of the edge protection!

Exception: The first bracket of the next standard deck is less than 0.60 m from the corner.

- ▶ Do not install the additional bracket directly under the securing housing of the infill deck!

- ▶ Swing up the securing element of the infill deck XBS (see section [Gap Filler Plank](#)).

- ▶ Lift the infill deck XBS to its intended location.

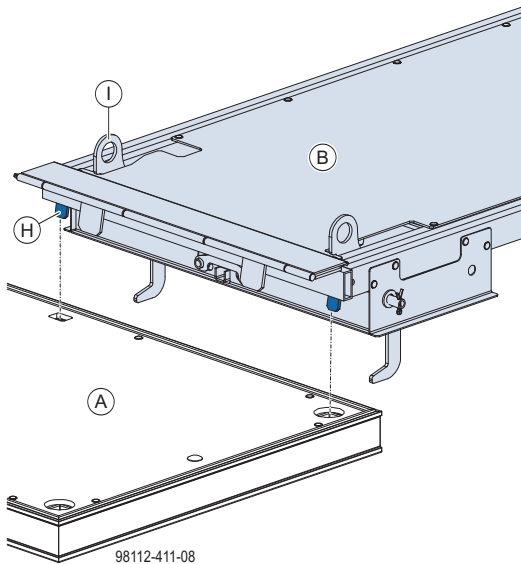

Suspension plates engage in the recesses in deck A - deck XBS.

- ▶ Close securing element and deck hatch (see section [Gap Filler Plank](#)).

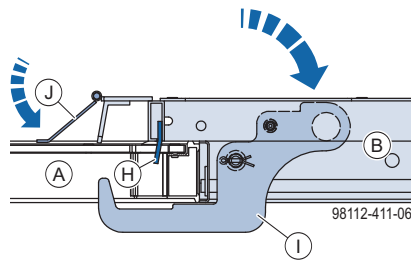

- A** Deck A - Deck XBS
- B** Deck B - Infill deck XBS
- H** Suspension plate for hooking into deck XBS
- I** Securing element
- J** Deck hatch



Do a sight-check to ensure that the securing element is closed.

- ▶ Install Handrail post XBS 1.40m and Protective grating XP 1.20m.

Inside corner with closure on both sides

2 infill decks XBS

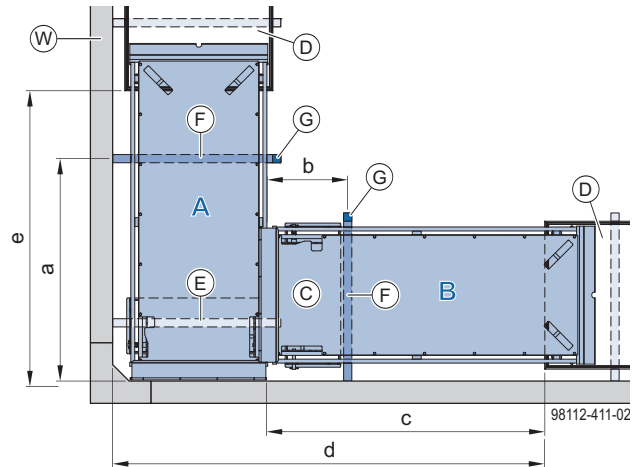

- a ... from inside corner to additional bracket XBS: 0.93 m - 1.53 m
- b ... from deck A to additional bracket XBS: 0.45 m - 0.60 m
- c ... 0.39 m - 1.44 m
- d ... 1.25 m - 2.30 m
- e ... 0.48 m - 1.53 m

- A** Deck A - Infill deck XBS
- B** Deck B - Infill deck XBS
- C** Securing housing of infill deck XBS
- D** Deck XBS (standard deck)
- E** Bracket XBS
- F** Bracket XBS (additionally required)
- G** Handrail post XBS 1.40 m
- W** Gang-form (schematic diagram)

Installation sequence:

1. Standard XBS deck (D)
2. Deck A (A)
3. Deck B (B)

Installation of deck A:



NOTICE

- ▶ Install the first bracket XBS as far in the corner as possible (immediately next to the inter-panel connections of the inside corner)!
- ▶ An additional bracket XBS with handrail post XBS is required for installation of the edge protection!
Exception: The first bracket of the next standard deck is less than 1.53 m from the corner.

- ▶ Lift the infill deck XBS to its intended location. The distance between the narrow side of the infill deck and the formwork should be as small as possible.
- ▶ Lift the anti-slip guard on the formwork side so that the securing hook of the bracket can engage in the toothed strip of the infill deck.

- ▶ Actuate the anti-slip guard briefly so that the anti-slip guard closes.

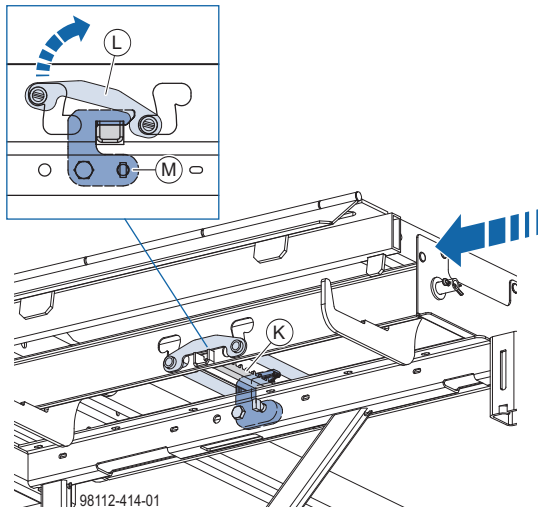

- K** Toothed strip for securing the position
- L** Anti-slip guard
- M** Securing hook

With the anti-slip guard closed, the deck is secured against slipping on the bracket.

Do a sight-check to ensure that the anti-slip guard is closed.

Installation of deck B:



NOTICE

- ▶ An additional bracket XBS with handrail post XBS is required for installation of the edge protection!
Exception: The first bracket of the next standard deck is less than 0.60 m from the corner.
- ▶ Do not install the additional bracket directly under the securing housing of the infill deck!

- ▶ Swing up the securing element of the infill deck (see section [Gap Filler Plank](#)).

- ▶ Lift the infill deck XBS to its intended location.

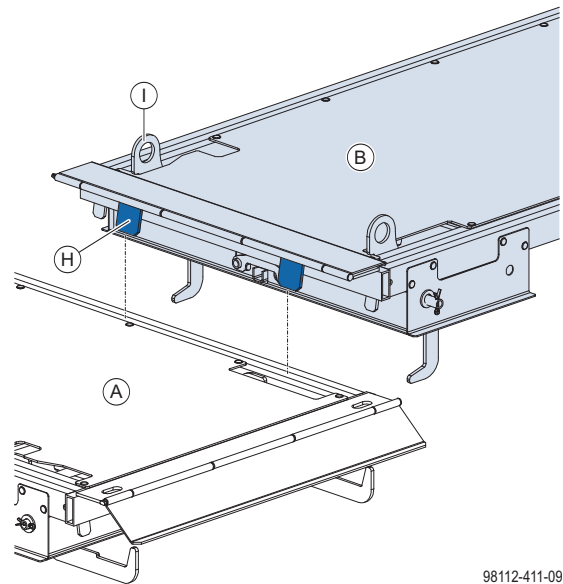

Suspension plates engage in the recess in deck A - infill deck XBS.

- ▶ Close the securing element (see [Gap Filler Plank](#)).

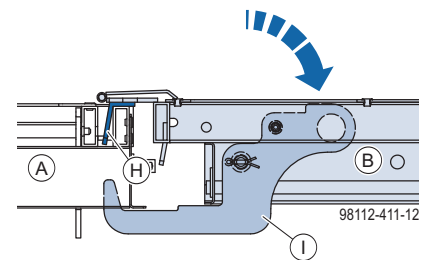

- A** Deck A - Infill deck XBS
- B** Deck B - Infill deck XBS
- H** Suspension plate for hooking into infill deck XBS
- I** Securing element

Do a sight-check to ensure that the securing element is closed.

- ▶ Install Handrail post XBS 1.40m and Protective grating XP 1.20m.

Sideguards on exposed platform-ends

On pouring platforms that do not completely encircle the structure, suitable sideguards must be placed across exposed end-of-platform zones.

Installation:

- ▶ Insert Side railing XBS 75cm into deck XBS.

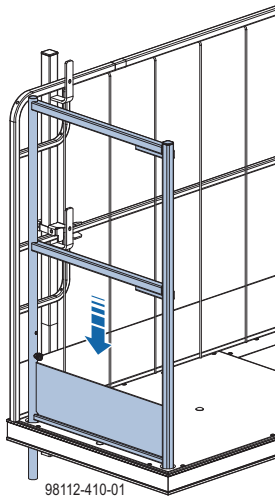

- ▶ Swing Side railing XBS 75cm 90° inwards and hook into Handrail post XBS 1.40m.

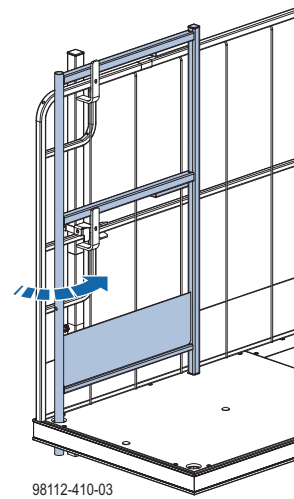

Safety latch (B) on post (C) must engage on the underside of deck XBS (A).

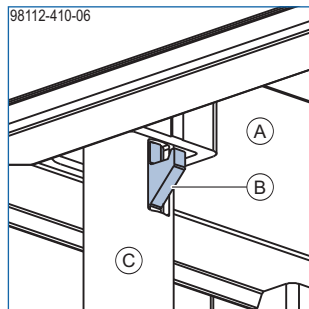

To open the side railing:

- ▶ Press the locking button and lift Side railing XBS 75cm by approx. 10 cm.

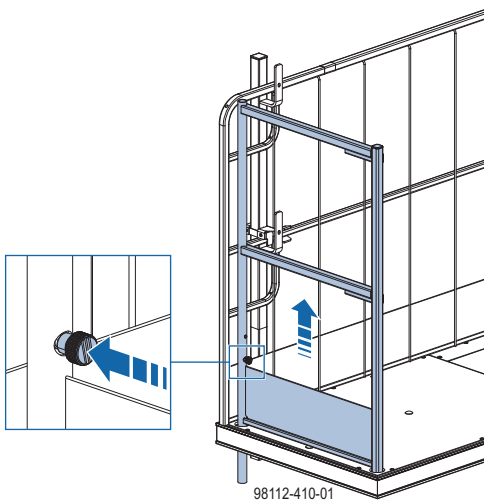

The end-of-platform sideguard can be extended with the Handrail extension XBS (D).

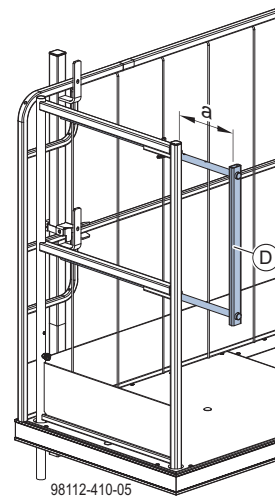

e ... can be telescoped between 15 cm and 60 cm in increments of 5 cm

Framax bracket 90

Note:

The plank and board thicknesses stated comply with the EN 338 C24 timber.

Observe all national regulations applying to deck and guardrail boards.

Framax brackets 90 are easy to assemble by hand and provide a 90 cm wide pouring platform.

Handrail post variants:

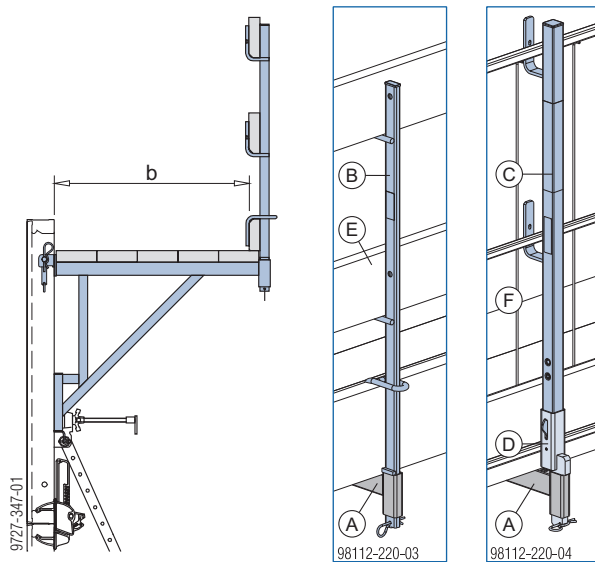

b ... 90 cm

- A Framax bracket 90 EP
- B Handrail post 1.00m
- C Handrail post XP 1.20m
- D Bracket adapter XP FRR 50/30cm
- E Guardrail board (or scaffold tube)
- F Protective grating XP 1.20m (or guardrail boards)

Permitted service load: 1.5 kN/m² (150 kg/m²)
 Load Class 2 to EN 12811-1:2003
 Max. influence width: 2.00 m



NOTICE

The brackets must be secured against accidental lift-out.

Deck-boards and guardrail boards: Per 1 metre length of platform, 0.9 m² of deck-boards and 0.6 m² of guardrail boards are needed (provided on site).

Board thicknesses for centre-to-centre spans up to 2.50 m:

- Deck-boards min. 20/5 cm
- Guardrail boards min. 15/3 cm

Bolting items required for securing the deck-boards (fasteners per bracket):

- 5 cup square bolts M10x120
- 5 spring washers A10
- 5 hexagon nuts M10

Fixing the guardrail boards: use nails

Using scaffold tubes

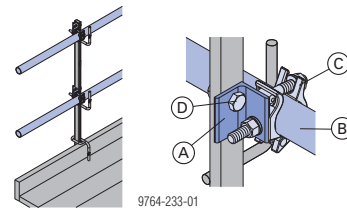

Tools required: Open-end spanner 22 for mounting the couplers and scaffold tubes.

- A Scaffold tube connection
- B Scaffold tube 48.3mm
- C Screw-on coupler 48mm 50
- D Hexagon bolt M14x40 + hexagon nut M14 (Bolting items required)

Possible ways of fixing to upright panels

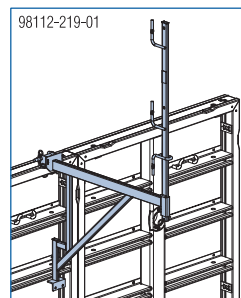

In the frame profile

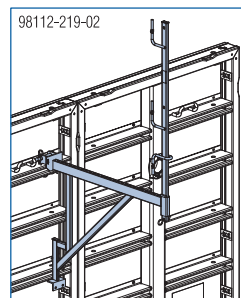

In the function profile

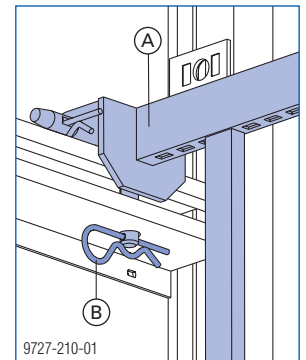

Anti-liftout guard

- A Framax bracket 90 EP
- B Spring cotter

Note:

Where brackets need to be fixed to the middle cross profile of upright Framax Xlife universal panels 2.70m and 3.30m (2008 models onward), this can also be done in the left-hand borehole.

Possible ways of fixing to horizontally placed panels

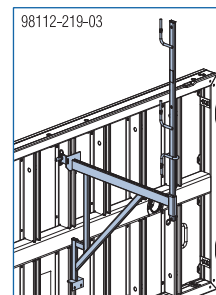

In the function profile

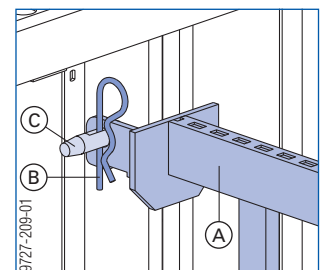

Anti-liftout guard

- A Framax bracket 90 EP
- B Spring cotter
- C Wedge bolt RA 7.5

Erection sequence



NOTICE

- For working at heights that cannot be reached from the floor, use a suitable elevated platform (e.g. Platform stairway 0.97m, Wheel-around scaffold DF or mobile scaffold tower)!
- Always comply with the country-specific safety regulations!
- Do not step on to the pouring platform until an all-round guardrail system (including counter railing) is in place!
Otherwise wear a personal fall-arrest system (e.g. safety harness)!

Note:

For details of the procedures for setting up and stripping the formwork, see the sections headed [Instructions for assembly and use for room-high formwork](#) and [Instructions for assembly and use for high formwork](#).

Horizontal assembly

- ▶ Pre-assemble the gang-form face-down on a prepared flat area (see the section headed [Inter-panel connections](#)).
- ▶ Attach the Tie-off set PPE type A for the personal fall-arrest system to the frame profile or function profile.

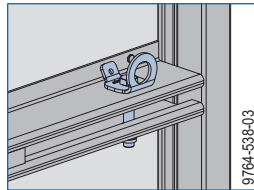
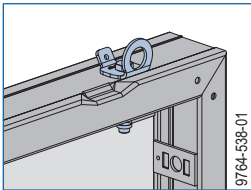

- ▶ Install brackets, decking and if applicable, end-of-platform sideguards and Ladder system XS on the gang-form while it is laid flat (see the sections headed [Framax bracket 90](#), [Sideguards on exposed platform-ends](#) and [Ladder system](#)).

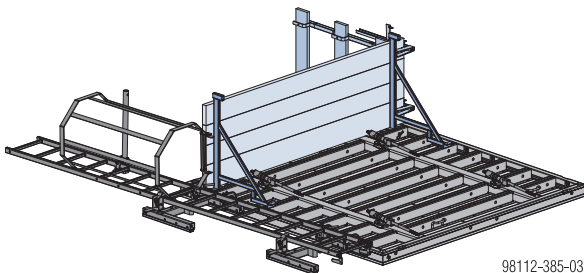

NOTICE

- ▶ Do not set down the gang-form on the pouring platform.
- ▶ Use the crane to turn the gang-form over so that the pouring platform is accessible from floor level.

- ▶ Install the handrail posts and safety barrier (see the section headed [Framax bracket 90](#)).

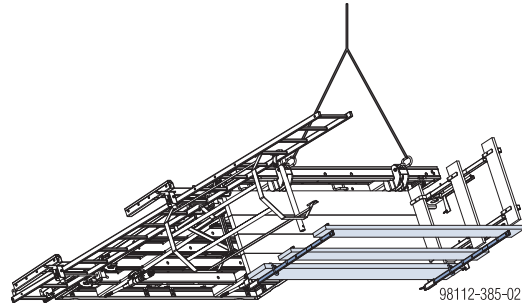

- ▶ Spray the formwork sheet with release agent (see the section headed [Cleaning and care of your equipment](#)).
- ▶ Lift the gang-form to its new location.
- ▶ Install the panel struts and secure them firmly to the floor. The top strut heads are reached by standing on an elevated platform (e.g. Platform stairway 0.97m).

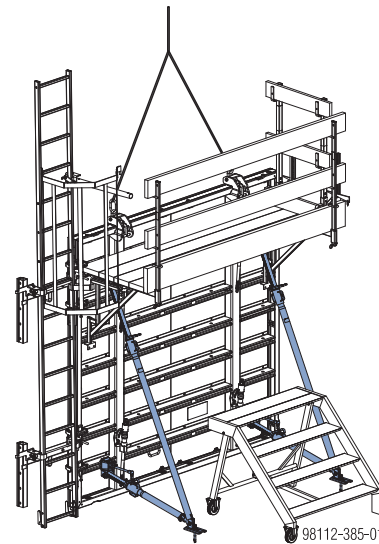

The gang-form is now stable and can be plumbed and aligned exactly, with no need for the crane.



WARNING

No all-round guardrail system present on the pouring platform!

Danger to life from fatal falls!

- ▶ Use a personal fall-arrest system (e.g. safety harness)
The Tie-off set PPE type A (**A**) connected to the framed formwork panel serves as attachment point.

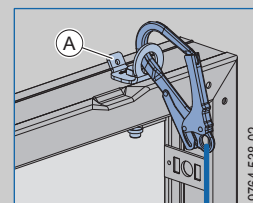

- ▶ Detach the gang-form from the crane.
Dismantling is the reverse of the assembly procedure.

Assembling in the upright

- ▶ Pre-assemble the gang-form face-down on a prepared flat area (see the section headed [Inter-panel connections](#)).
- ▶ Install panel struts and, if applicable, Ladder system XS (incl. ladder cage, if necessary) on the gang-form while it is lying flat (see the sections headed [Plumbing accessories](#) and [Ladder system](#)).

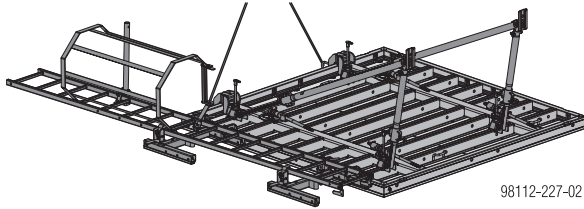

- ▶ Raise the gang-form by crane.
- ▶ Spray the formwork sheet with release agent (see the section headed [Cleaning and care of your equipment](#)).
- ▶ Fly the gang-form to its new location.
- ▶ Fix the panel struts to the ground stably. The gang-form is now stable and can be plumbed and aligned exactly, with no need for the crane.
- ▶ Use the Framax assembling tool to disengage the Framax lifting hooks from the gang-form (see the section headed [Lifting by crane](#)).

Assembling the pouring platform:

The pouring platform is installed from an elevated platform (e.g. Wheel-around scaffold DF).



NOTICE

- ▶ If the formwork height is 3.30m, install the brackets in the second function profile from the top to ensure reachability for installation from the elevated platform.
- ▶ Install the brackets and handrail posts (see the section headed [Framax bracket 90](#)).
- ▶ Install the guardrail boards (starting at the top) or protective gratings, as applicable (see the section headed [Framax bracket 90](#)).

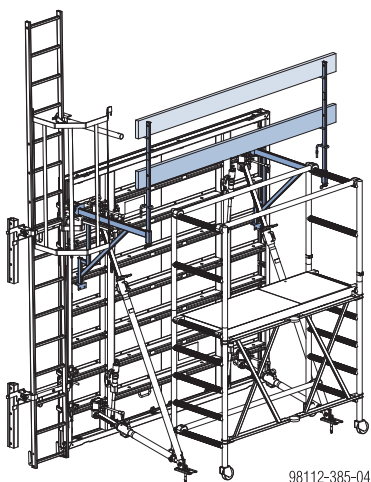

The Alu beam fork H20 (A) is a helpful tool for inserting the guardrail boards.

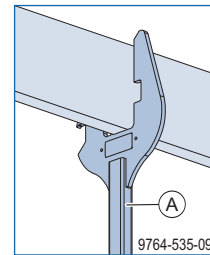

- ▶ Install the deck-boards (starting at the formwork side) (see the section headed [Framax bracket 90](#)).

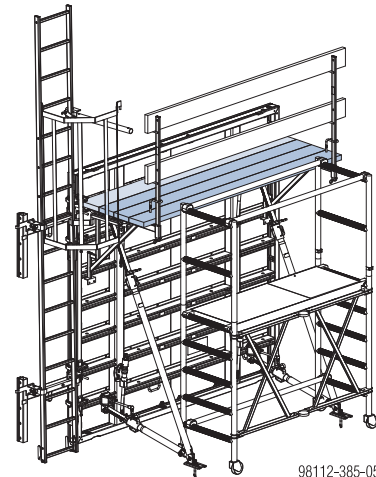

- ▶ Install the toeboards and, if applicable, the end-of-platform sideguards (see the sections headed [Framax bracket 90](#) and [Sideguards on exposed platform-ends](#)).

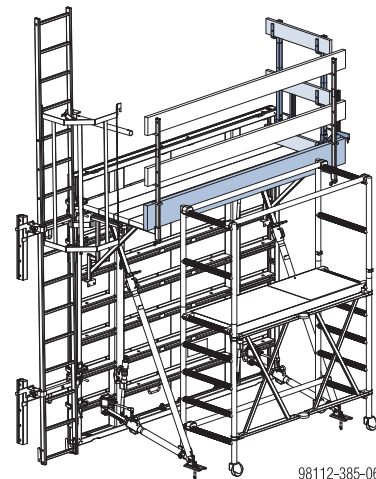

Dismantling is the reverse of the assembly procedure.

Assembly procedure for high formwork

- ▶ Pre-assemble gang-forms face-down on an assembly area.
- ▶ Attach the Tie-off set PPE type A for the personal fall-arrest system to the frame profile or function profile.

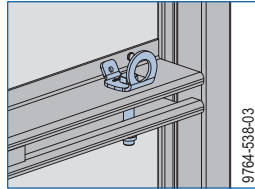
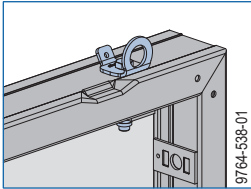

- ▶ Only mount the pouring platforms, ladder system and panel struts to the gang-form when this is laid flat on its back.

The topmost guardrail board is not installed until the gang-form is upright - secure it to the decking until then!

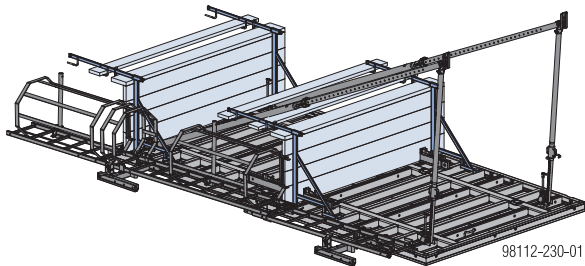

- ▶ Raise the gang-form by crane.
 - ▶ Spray the formwork sheet with release agent.
 - ▶ Lift the gang-form to its new location.
 - ▶ Fix the panel struts to the ground stably.
- The gang-form is now stable and can be plumbed and aligned exactly, with no need for the crane.



WARNING

No all-round guardrail system present on the pouring platform!

Danger to life from fatal falls!

- ▶ Use a personal fall-arrest system (e.g. safety harness)
- The Tie-off set PPE type A (**A**) connected to the framed formwork panel serves as attachment point.

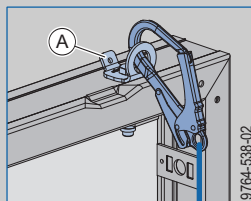

- ▶ Detach the gang-form from the crane.

- ▶ Mount the top guardrail board.

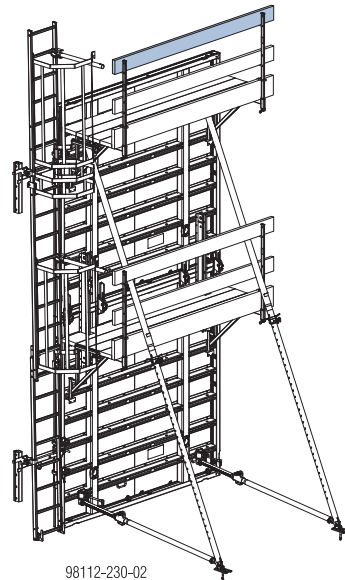

Dismantling is the reverse of the assembly procedure.

Sideguards on exposed platform-ends

On pouring platforms that do not completely encircle the structure, suitable sideguards must be placed across exposed end-of-platform zones.

Xsafe edge protection XP

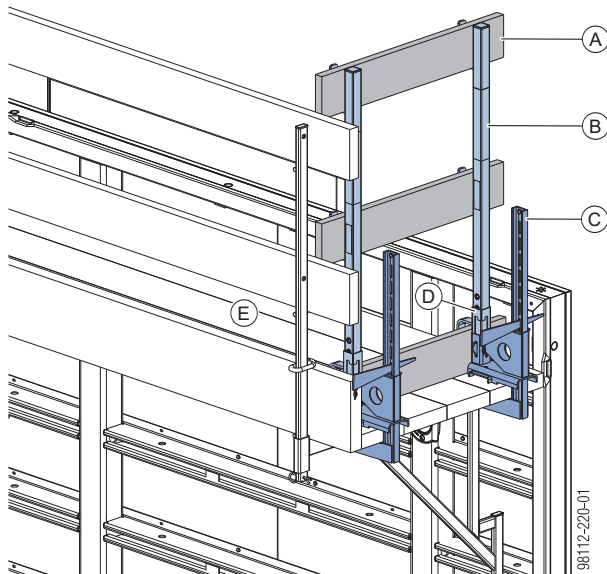

A Guardrail board min. 15/3 cm (site-provided)

B Handrail post XP 1.20m

C Railing clamp XP 40cm

D Toeboard holder XP 1.20m

E Pouring platform

Installation:

- ▶ Fasten Railing clamps XP onto the decking of the pouring platform, by tightening the wedge (clamping range 2 to 43 cm).
- ▶ Working from below, push a Toeboard holder XP 1.20m onto the Handrail post XP 1.20m.
- ▶ Push the Handrail post XP 1.20m into the post-holding fixture on the railing clamps until the locking mechanism engages.
- ▶ Fix guardrail boards to the railing shackles with nails (diam. 5 mm).

Handrail clamp S



Follow the directions in the "Handrail clamp S" User information!

Opposing guardrail

If there are work platforms mounted on one side of the formwork only, then a fall-protection barrier must be mounted to the opposing formwork.

Note:

The plank and board thicknesses stated comply with the EN 338 C24 timber..

Observe all national regulations applying to deck and guardrail boards.

Xsafe edge protection XP

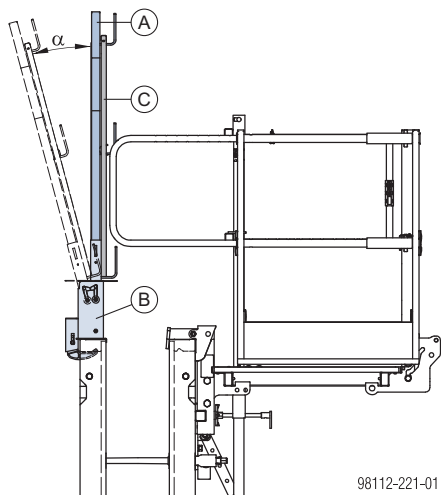

98112-221-01

α ...15°

- A** Handrail post XP
- B** Framax adapter XP
- C** Protective grating XP or guardrail boards

If necessary (e.g. to enlarge the available work-space during pouring), the safety barrier can be tilted outward by 15°.

► Push up the safety bolt on the Adapters XP until the spring snaps into place (allow for overlap between protective gratings and/or guardrail boards).

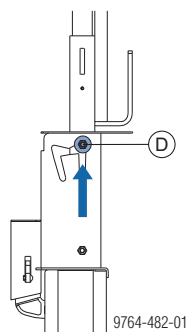

9764-482-01

- D** Safety bolt

► Tilt the safety barrier outward.

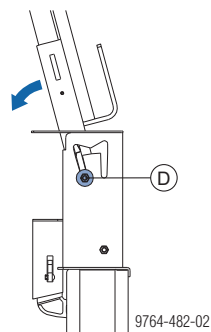

9764-482-02

- D** Safety bolt

The safety bolt now automatically drops and secures the tilted barrier unit.



Do a sight-check to make sure that the safety bolt is in the correct position!

Types of safety barrier:

	Protective grating XP	Guardrail boards
Handrail post XP 1.20m	<p>9764-480-03</p>	<p>9764-480-04</p>
Handrail post XP 0.60m	<p>9764-480-07</p>	<p>9764-540-01</p>

- a ... 143 cm
- b ... 93 cm
- c ... min. 100 cm
- d ... 103 cm
- e ... 106 cm

- E** Handrail post XP 1.20m
- F** Handrail post XP 0.60m
- G** Protective grating XP 1.20m
- H** Protective grating XP 0.60m
- I** Platform decking
- J** Guardrail board min. 15 cm (site-provided)



NOTICE

- Note the necessary minimum distance of 100 cm from platform decking to top of railing!
- When Handrail posts XP 1.20m and guard-rail boards are used to construct the safety barrier, it is not permissible to install guard-rail boards in the top railing shackles!

Assembly

The opposing guard-rail can be mounted to both upright and face-down (ground-assembled) gang-forms.



NOTICE

- ▶ Do not position the Framax adapter XP directly over a lifting edge!

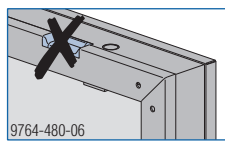

- ▶ Mount the Framax adapter XP on the frame profile and fix it in place with the wedge.

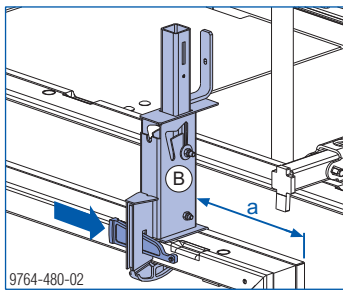

a ... ca. 35 cm (position of the two endmost Framax adapters XP on a gang-form)

B Framax adapter XP

- ▶ Push the handrail post XP into the post-holding fixture on the Framax adapter XP until the locking mechanism engages.
- ▶ Fit on a Protective grating XP or guardrail boards.
- ▶ Use Velcro® fasteners 30x380mm to secure the Protective gratings XP to the Handrail posts XP, or use nails (diam. 5 mm) to secure guardrail boards.

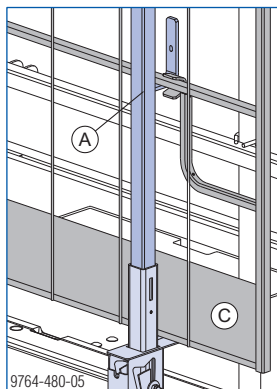

A Handrail post XP

C Protective grating or guardrail boards

Lifting by crane

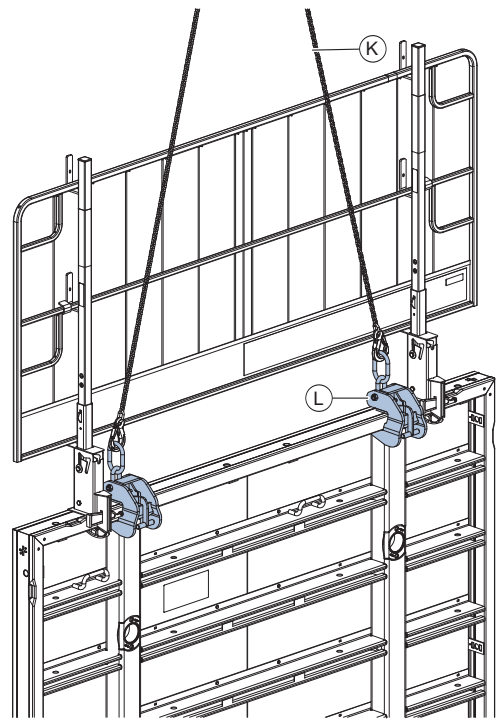

K Doka 4-part chain 3.20m

L Framax lifting hook

When lifting gang-forms together with counter railings assembled from the Xsafe edge protection XP, remember the following points:

- The guard rails must be in the vertical position when the gang-form is raised or laid down.
- Elastic deformation of the guard rails may occur because the 4-part chain is resting against the protective grating or guardrail boards while the gang-form is being lifted.
- When a gang-form is lifted, repositioned or laid down, the 4-part chain must not be led around the protective grating or the guardrail board.

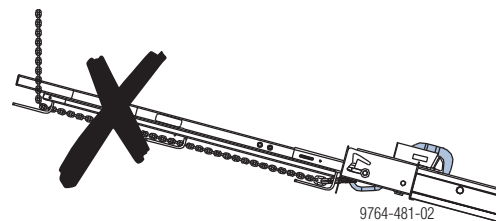

Make sure that the 4-part chain is in the right position:

- Placing down onto the form-ply side
- Picking up from this position

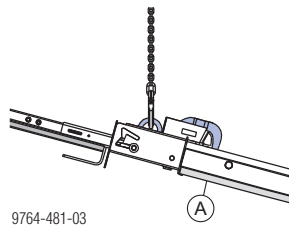

- Placing down onto the back-face of the formwork (e.g. for cleaning the form-facing)
- Picking up from the cleaning position
- Repositioning the upright gang-form

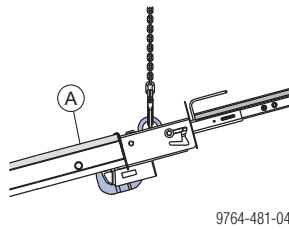

A Form-ply side

Structural design

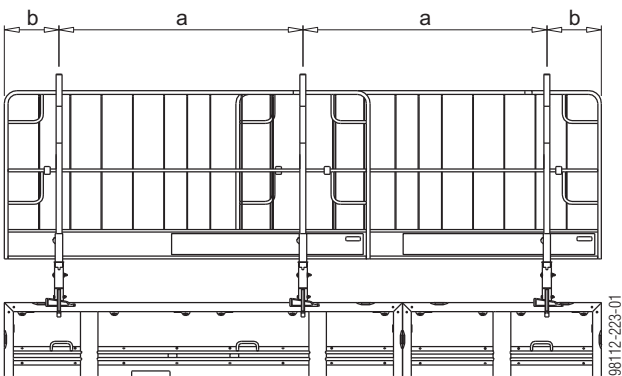

a ... span
b ... cantilever

Note:

The wind conditions likely to be encountered in Europe, in accordance with EN 13374, are largely recognised by the peak velocity pressure $q=0.6 \text{ kN/m}^2$ (highlighted in the tables).

Permitted span (a)

		Peak velocity pressure q [kN/m ²]			
		0.2	0.6	1.1	1.3
Permitted span	Protective grating XP	2.5 m		—	
	Guardrail board 2.4 x 15 cm	1.9 m			
	Guardrail board 3 x 15 cm	2.7 m			
	Guardrail board 4 x 15 cm	3.3 m			

Permitted cantilever (b)

		Peak velocity pressure q [kN/m ²]			
		0.2	0.6	1.1	1.3
Permitted cantilever	Protective grating XP	0.6 m	0.4 m	—	
	Guardrail board 2.4 x 15 cm	0.5 m			
	Guardrail board 3 x 15 cm	0.8 m			
	Guardrail board 4 x 15 cm	1.4 m			

Handrail post 1.10m

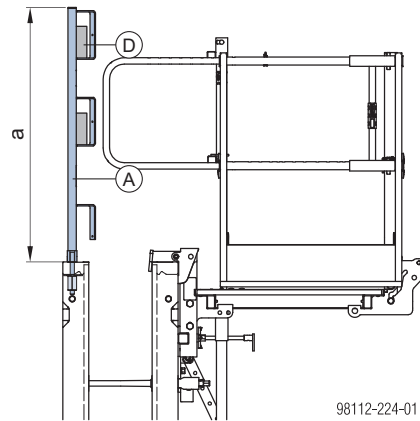

a ... 120 cm

- A** Handrail post 1.10m
- D** Guardrail board

Installation:

- Secure the Handrail post 1.10m in the cross bore-hole of the framed formwork panel using the Hexagon nut 20.0.

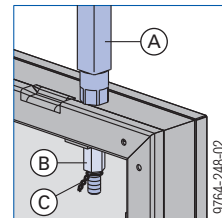

- A** Handrail post 1.10m
- B** Hexagon nut 20.0
- C** Hexagon nut secured in place (e.g. with safety wire)

- Secure the Hexagon nut 20.0 in place.



NOTICE

Before the gang-form is repositioned by crane, the guardrail boards must be removed!



Follow the directions in the 'Handrail post 1.10m' User Information booklet.

Wall formwork at the edge of the structure

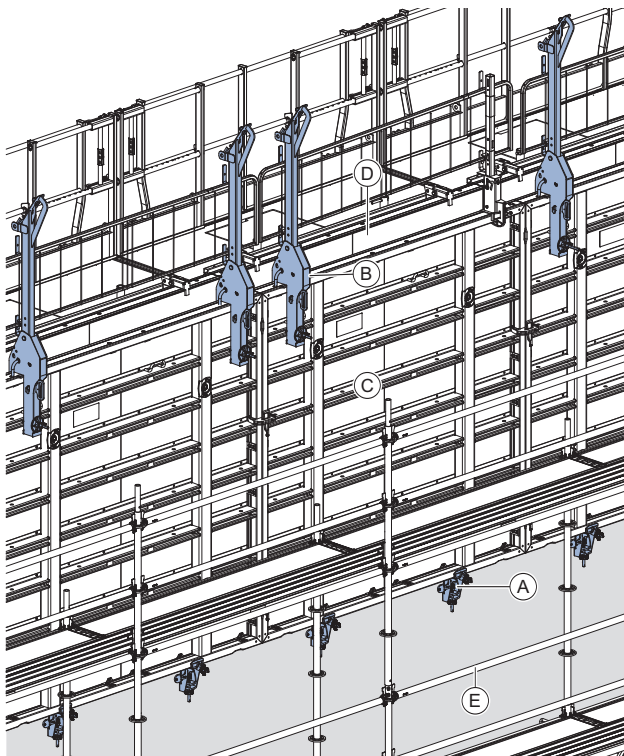

98112-392-07

- A** Wall-formwork support angle 2G or Wall-formwork support angle
- B** Framax panel strut connector I
- C** Holding formwork
- D** Opposing formwork
- E** Façade scaffolding (e.g. Working scaffold Modul)

Wall-formwork support angle 2G

The **Wall-formwork support angle 2G** is used for positioning wall formwork at the edge of the structure if there is no suitable load-bearing base (e.g. platform). It offers a dual function with which the support angle can be secured either with a Bridge edge beam anchor 15.0 or alternative anchorages.

Possible anchorages:

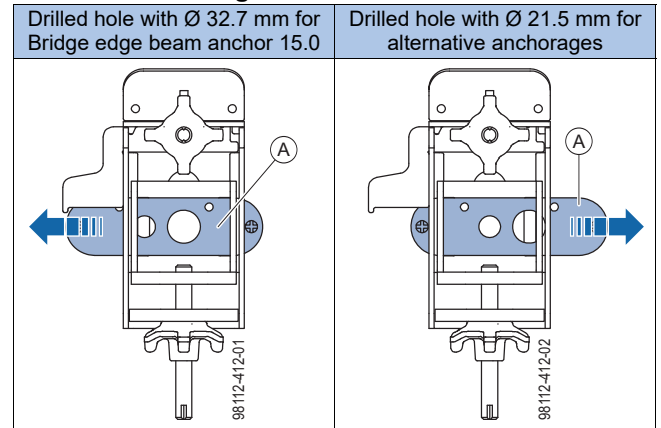

A Plate for pushing to the respective drilled hole

Drilled hole with Ø 32.7 mm for Bridge edge beam anchor 15.0:

Permissible load-bearing capacity per support angle Wall formwork 2G: (Values apply to uncracked concrete)		
Concrete strength class: min. C20/25 Cube compressive strength of the concrete during loading $f_{ck, cube, current}$		
10 N/mm ² (corresponds to B10)	15 N/mm ² (corresponds to B15) or higher	
Maximum load $F_{permissible}$	16.7 kN	20.0 kN



NOTICE

- Installation of the support angle is done by crew members working from the leading façade scaffold!

Note:

A **Bridge edge beam anchor 15.0** has to be set into the concrete when the preceding section is poured so that the support angle can be secured to it.



Follow the directions in the 'Bridge edge beam anchor 15.0' User Information booklet.

Drilled hole with Ø 21.5 mm for alternative anchorage:

		Maximum load $F_{\text{permissible}}$ [kN]			
		5.0	10.0	15.0	20.0
Resulting minimum resistances of the alternative anchorage from the load $F_{\text{permissible}}$	Characteristic tensile force $N_{R,k}$	4.5	9.0	13.5	17.9
	Design tensile force $N_{R,d}$	6.7	13.5	20.2	26.9
	Characteristic shear force $V_{R,k}$	5.0	10.0	15.0	20.0
	Design shear force $V_{R,d}$	7.5	15.0	22.5	30.0



NOTICE

- Statical verification is required!
- Installation of the support angle is done by crew members working from the leading façade scaffold!
- The alternative anchorages must be selected not only according to the forces but also according to the compressive strength of the concrete and the minimum distances.

Installation:

- Remove the nailing cone from the bridge edge beam anchor.

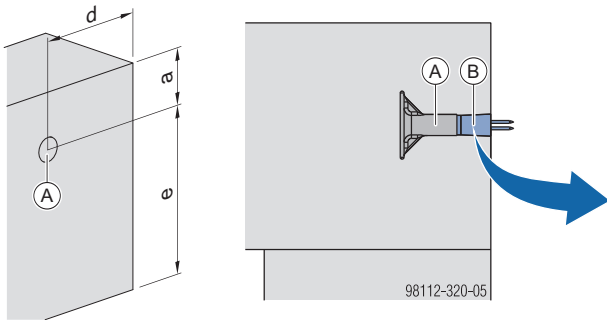

a ... min. 11.0 up to max. 14.0 cm
 d ... min. 20 cm
 e ... min. 45 cm

A Bridge edge beam anchor 15.0

B Nailing cone 15.0

- 1) Secure the support angle to the bridge edge beam anchor with a Screw-in cone 15.0 (but do not yet tighten).
- 2) Use the lower vertical star grip nut to adjust to the necessary level (**b**).

- 3) Tighten the Screw-in cone 15.0.

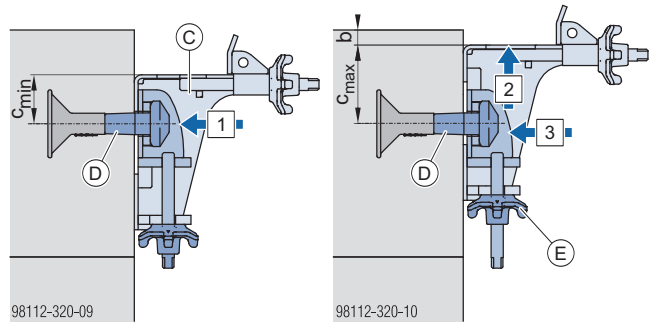

b ... offset approx. 1.0 cm
 (so that the formwork can be tightened against the wall/slab)

	Bridge edge beam anchor 15.0	Alternative anchorage
c_{min} ...	6.5 cm	6.0 cm
c_{max} ...	11.5 cm	12.0 cm
Max. adjustment range ...	5.0 cm	6.0 cm

C Wall-formwork support angle 2G

D Screw-in cone 15.0

E Star grip nut vertical



Check that the support angle is correctly seated flat against the wall.

- 4) Place the formwork on the support angle.
- 5) Press the formwork against the structure using the upper horizontal star grip nut.

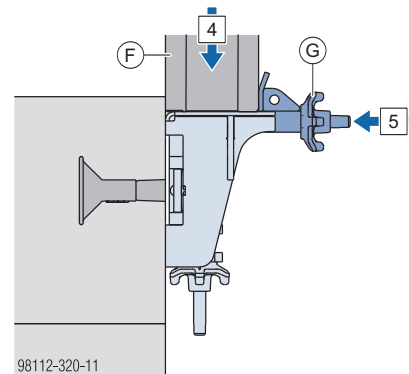

F Formwork

G Star grip nut horizontal

- 6) Secure the formwork on the support angle with Framax multi function clamp or Framax adjustable clamp to prevent lifting out.

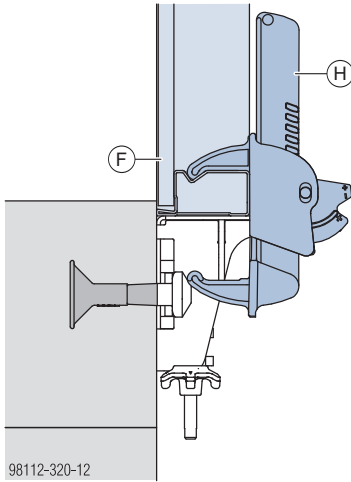

F Formwork
H Framax multi function clamp or Framax adjustable clamp

Wall-formwork support angle

The **Wall-formwork support angle** is a support for positioning wall formwork at the edge of the structure if there is no suitable load-bearing base (e.g. platform).

Drilled hole with Ø 32.7 mm for Bridge edge beam anchor 15.0:

Maximum load $F_{\text{permissible}}$	Permissible load-bearing capacity per support angle Wall formwork: (Values apply to uncracked concrete)	
	10 N/mm ² (corresponds to B10)	15 N/mm ² (corresponds to B15) or higher
	16.7 kN	20.0 kN

Concrete strength class: min. C20/25
Cube compressive strength of the concrete during loading $f_{ck, \text{cube, current}}$



NOTICE

- Installation of the support angle and tying of the panels are jobs undertaken by crew members working from the leading façade scaffolding!

Note:

A **Bridge edge beam anchor 15.0** has to be set into the concrete when the preceding section is poured so that the support angle can be secured to it.



Follow the directions in the 'Bridge edge beam anchor 15.0' User Information booklet.

Installation:

- Remove the nailing cone from the bridge edge beam anchor.

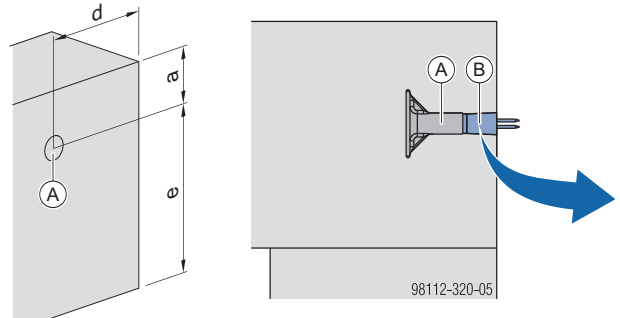

a ... min. 11.0 up to max. 14.0 cm
d ... min. 20 cm
e ... min. 45 cm

A Bridge edge beam anchor 15.0
B Nailing cone 15.0

- Secure the support angle to the bridge edge beam anchor with a Screw-in cone 15.0 (but do not yet tighten).
- Use the star grip nut for adjusting to the necessary level (b).
- Tighten the Screw-in cone 15.0.

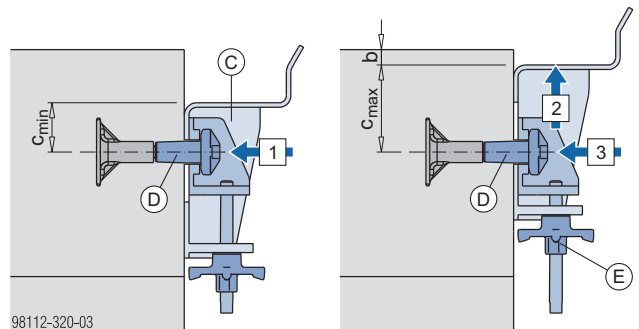

b ... offset approx. 1.0 cm
(so that the formwork can be tightened against the wall/slab)
Adjustment range c_{min} ... 6.5 to c_{max} ... 11.5 cm = 5 cm

C Wall-formwork support angle
D Screw-in cone 15.0
E Star grip nut



Check that the support angle is correctly seated flat against the wall.

- Place the formwork on the support angle.

- 5) Use a wedge to tighten the formwork against the wall/slab.

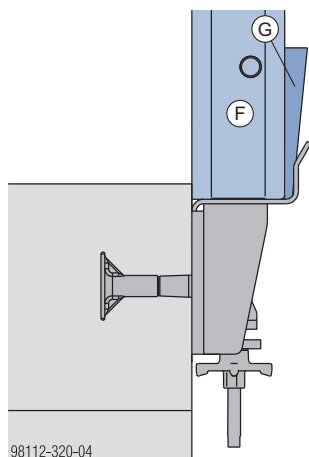

- F Opposing formwork
- G Wedge

Framax panel strut connector I

The **Framax panel strut connector I** is for connecting panel struts for temporary support of panels in gang-forms at the structure edge and also functions as a handrail post for the counter railing.

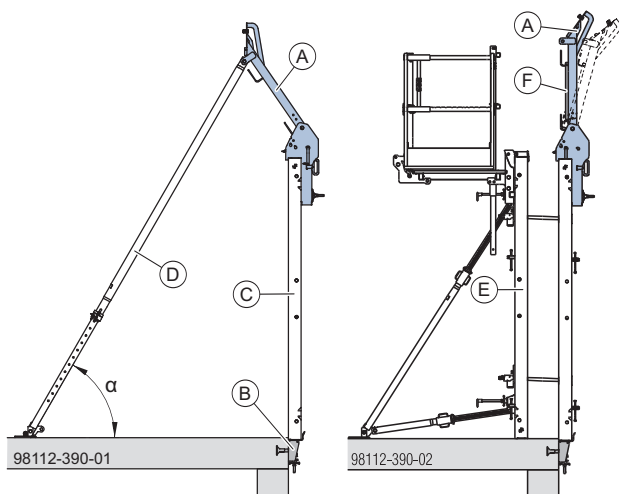

α ... approx. 60°

- A Framax panel strut connector I
- B Wall-formwork support angle
- C Holding formwork
- D Panel strut
- E Opposing formwork
- F Protective grating XP 0.60m

Pin position:

- Pos. (1): panel bracing
- Pos. (2): counter railing
- Pos. (3): counter railing inclined

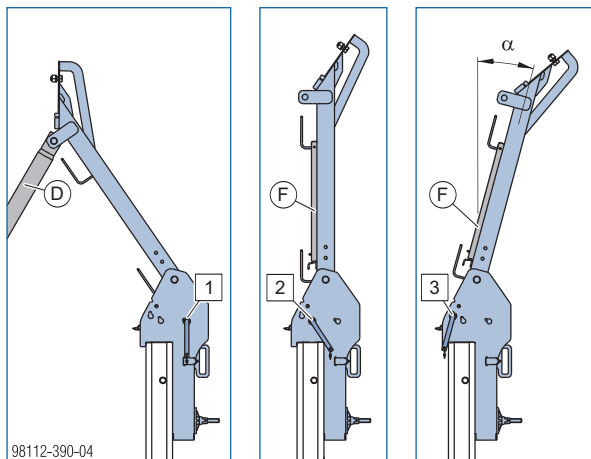

α ... 15°

- D Panel strut
- F Protective grating XP 0.60m

Plumbing accessory depending on formwork height and permissible influence width

Formwork height [m]	2.70	3.30	4.05	4.65	5.40	6.60	7.00
DokaRex 450 IB	✓	—	—	—	—	—	—
alignment 750 IB	✓	✓	✓	✓	—	—	—
strut 1020 IB	—	—	—	—	✓	✓	✓
Plumbing strut 540 IB	✓	✓	—	—	—	—	—
Eurex 60 550	Type 1	✓	✓	—	—	—	—
	Type 2	—	—	✓	✓	✓	—
	Type 3	—	—	—	—	—	✓
Influence width [m]	4.05	3.30	2.70	2.30	1.90	1.50	1.35

See also the section headed [Plumbing accessories](#)

Note:

- The values apply where the wind pressure $w_e = 0.52 \text{ kN/m}^2$. This results in a peak velocity pressure $q_p = 0.4 \text{ kN/m}^2$ (91 km/h) where $c_{p, net} = 1.3$. The greater wind loads encountered at exposed formwork-ends must be restrained by additional plumbing accessories (e.g. struts or pipe-braces). In cases where higher wind pressure is encountered, the number of struts must be determined by statical calculation!
- Values apply for an angle α of the plumbing strut of 60°.
- Values do not apply for gang-forms in the edge zone or for free-standing gang-forms.
 - Gang-forms in the edge zone must be supported by at least 2 plumbing accessories.
 - Free-standing gang-forms must be supported by at least 2 plumbing accessories.

Note:

The position can differ from case to case. (Distance when used as panel bracing \neq span when used as handrail post)
 In this case additionally use Framax adapter XP + Handrail post XP 0.60m (see the section headed [Opposing guardrail](#))!

Installation of Framax panel strut connector I

Installation on gang-form:

- ▶ Lay gang-form flat on supporting timbers (min. 10 cm)
- ▶ Position panel strut connector at the top edge of the formwork.
- ▶ Close anti-liftout guard and secure with spring cotter.

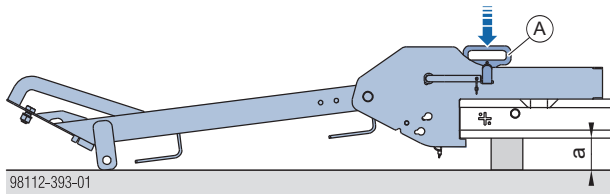

a ... min. 10 cm

A Anti-liftout guard



Check that anti-liftout guard **(A)** is correctly closed and secured with Spring cotter 5mm **(B)**.

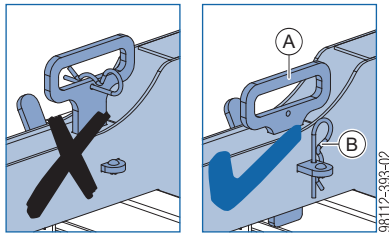

- ▶ Fix panel strut connector to function profile with Framax universal fixing bolt and Super plate 15.0.

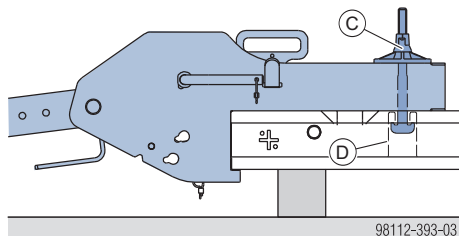

C Framax universal fixing bolt + Super plate 15.0

D Function profile in panel

Installation of panel struts:

- ▶ Pin strut into panel strut connector.

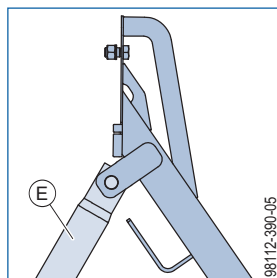

E Panel strut

Installation of panel struts when docking head is used:

- ▶ Secure docking head to panel strut connector with bolt and nut.

- ▶ Install panel strut in docking head.

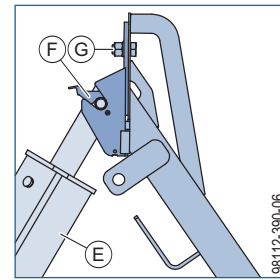

F Docking head or DokaRex docking head M20

G Hexagon bolt M20x40 + hexagon nut M20
(Included in scope of supply of Panel strut connector I)

E Panel strut



Follow the directions in the 'Eurex 60 550' or 'Alignment struts DokaRex' User Information booklet, as applicable.

Formwork set-up at structure edge

Note:

- For details of the procedures for setting up and stripping the formwork, see the section headed [Instructions for assembly and use for room-high formwork](#).
- As an alternative to the procedure shown here, the holding formwork can be positioned first and then the opposing formwork can be lowered by crane without panel struts on to the support angles.



NOTICE

- A mounted-ahead façade scaffold is necessary for work at the structure edge!
- For working at heights that cannot be reached from the floor, use a suitable elevated platform (e.g. Platform stairway 0.97m, Wheel-around scaffold DF or mobile scaffold tower)!
- Always comply with the country-specific safety regulations!
- If adequate fall protection is not available, use personal fall-arrest systems (e.g. safety harness)!
- 2 panel struts must be installed at the first and at the last gang-form.

- Install and align the Wall-formwork support angle (see the section headed [Wall-formwork support angle](#)).
- Install the panel strut connector on the gang-form (see the section headed [Framax panel strut connector I](#)).
- Remove fastening pin of the Panel strut connector I.

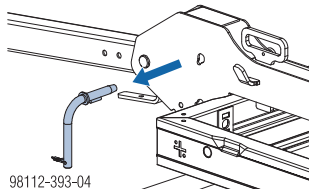

- Attach the gang-form to the crane with Framax lifting hooks (see the section headed [Lifting by crane](#) and the 'Framax lifting hook' Operating Instructions).
- Crane-lift the gang-form approx. 1.50 m.

- Secure fastening pin in pos. (1).

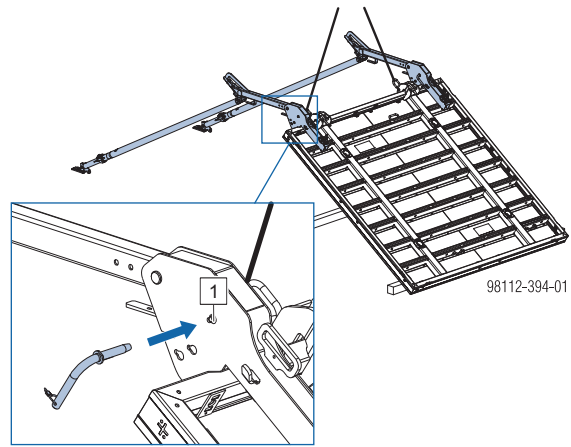

- Spray the formwork sheet with release agent (see the section headed [Cleaning and care of your equipment](#)).
- Lower the gang-form on to the support angle by crane.
- Press formwork against wall/slab.

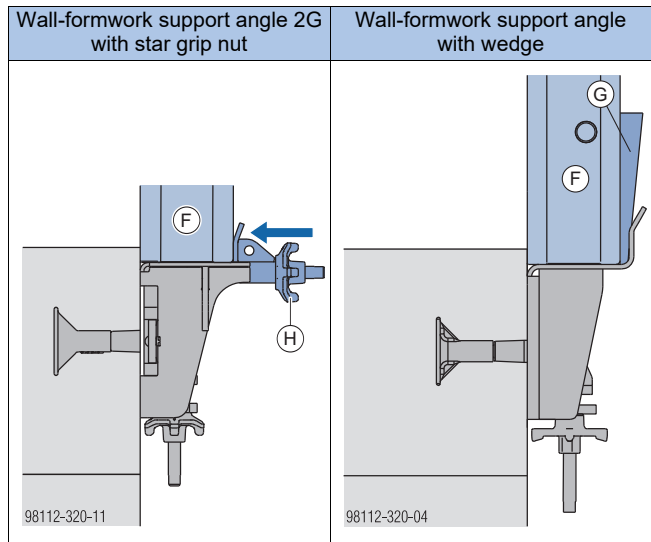

F Opposing formwork

G Wedge

H Star grip nut horizontal



NOTICE

Never use a sledge hammer to plumb and align the panels!

This would damage the profiles of the gangs.

- ▶ Use only proper aligning tools (e.g. a special pry-bar) that cannot cause any damage (see the section headed [Tools for plumbing and aligning and for stripping the formwork](#)).

- ▶ Fix the panel struts firmly to the ground (see the section headed [Plumbing accessories](#)).

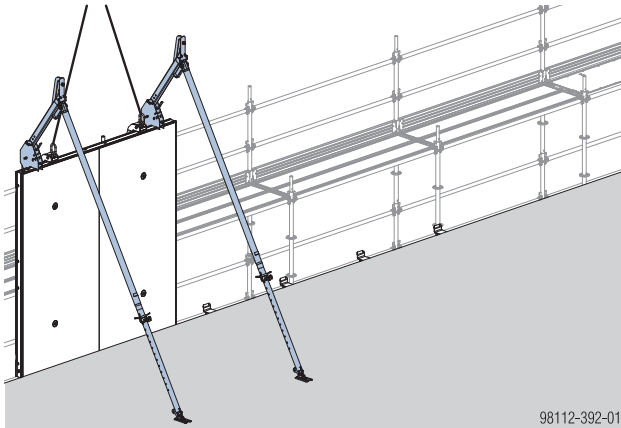

98112-392-01

The gang-form is now stable and can be plumbed and aligned exactly, with no need for the crane.

- ▶ Working from the façade scaffold, detach gang-form from the crane.
- ▶ Continue lining up further gang-forms in this way, and link them together (see the section headed [Inter-panel connections](#)).

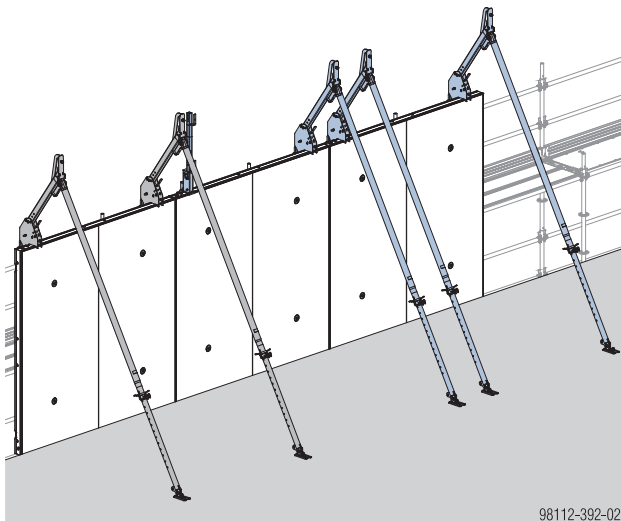

98112-392-02

Erecting the opposing formwork:



NOTICE

- Observe the sequence for erecting the opposing formwork!
- Start at the second-last gang-form!

Example: Sequence for 4 gang-forms

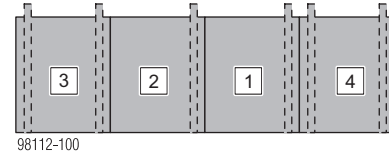

98112-100

Once the reinforcement has been placed, the formwork can be closed.

- ▶ Remove panel strut from second-last gang-form of the holding formwork.

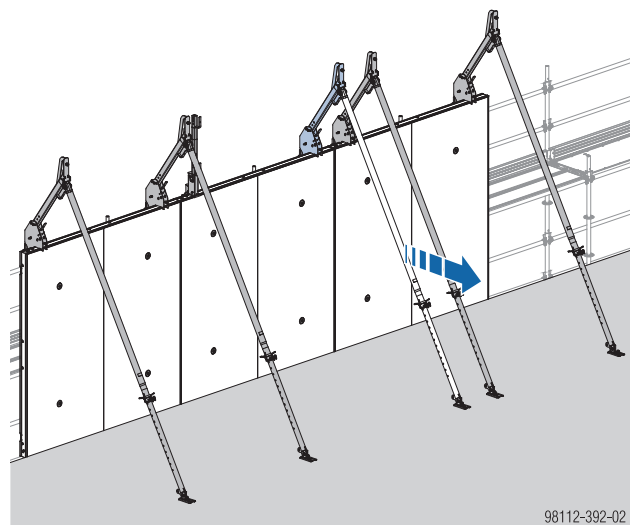

98112-392-02

- ▶ Spray the formwork sheet of the opposing formwork with release agent (see the section headed [Cleaning and care of your equipment](#)).
- ▶ Lift the opposing formwork (with closed platform) by crane to its next location.
- ▶ Fit the form ties (see the section headed [Tie rod system Framax Xlife plus](#)).
- ▶ Pin Framax panel strut connector I in pos. (2).

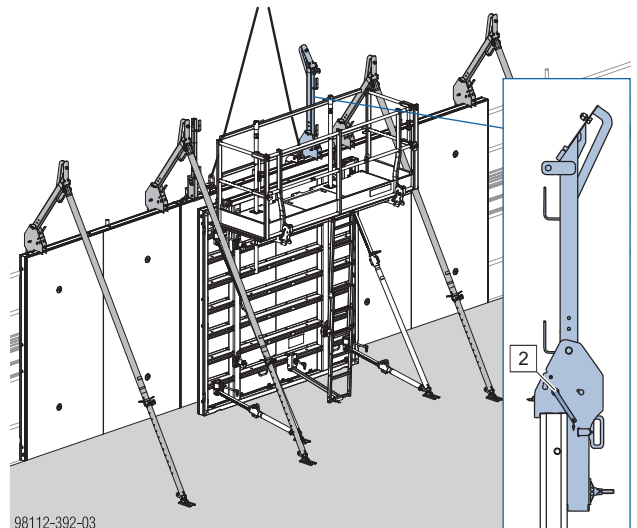

98112-392-03

- ▶ Detach the gang-form from the crane.
- ▶ Hook Protective grating XP 0.60m into position and retract Xsafe plus counter railing.

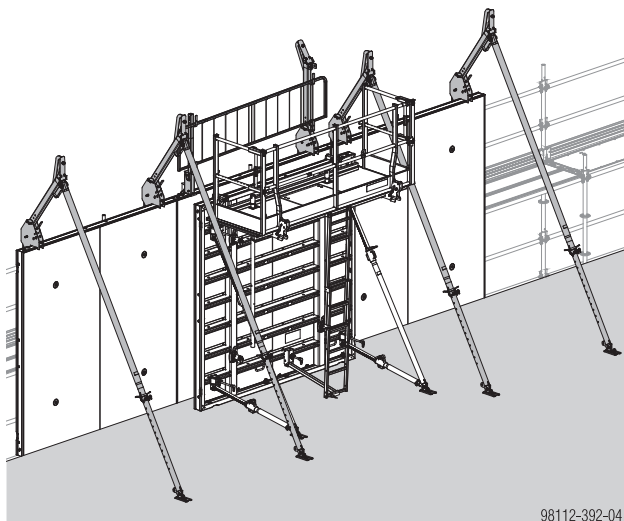

- ▶ Continue lining up further gang-forms in this way, and link them together (see the section headed [Inter-panel connections](#)).

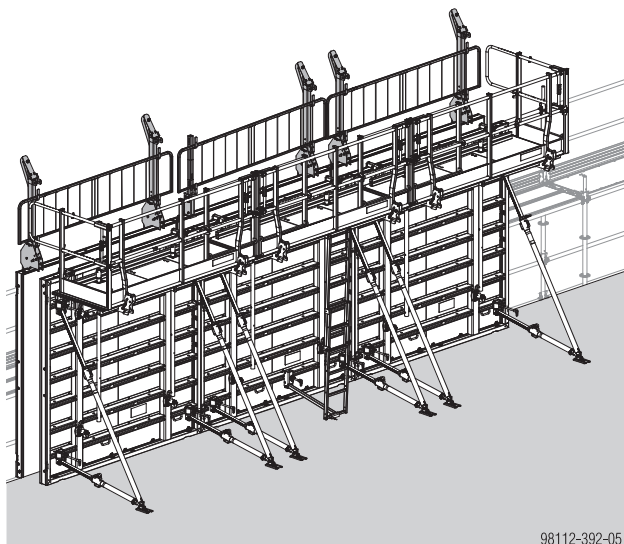

Pouring



NOTICE

Do not exceed the maximum permissible rate of placing.

Framed formwork Framax Xlife plus:

Permissible fresh-concrete pressure: See sections [Framax Xlife plus panel in detail](#) and [Tie rod system Framax Xlife plus](#).



Observe the section 'Pressure of fresh concrete on vertical formwork, DIN 18218' in the Calculation Guide 'Doka formwork engineering' or contact Doka.



Observe DIN 4235 Part 2 'Compacting of concrete by vibrating; Compacting by internal vibrators'.

- ▶ Pour the concrete.
- ▶ Make only moderate use of vibrators, carefully coordinating the times and locations of vibrator use.

Stripping the formwork



NOTICE

▶ Comply with the stipulated stripping times.

- ▶ Remove any loose items from the formwork and platforms, or secure them firmly.
- ▶ Attach the gang-form to the crane.
- ▶ Raise Xsafe plus counter railing and remove counter railing of the formwork.
- ▶ Take out the form ties (see the section headed [Tie rod system Framax Xlife plus](#)) and undo the connectors to the adjacent panels.



WARNING

The formwork tends to adhere to the concrete. When stripping the formwork, do not try to break concrete cohesion using the crane!

Risk of crane overload.

▶ Use suitable tools such as timber wedges or a special pry-bar to detach the formwork from the concrete.

- ▶ Lift the gang-form away and to its next location.
- ▶ Clean residual concrete off the formwork sheet (see the section headed [Cleaning and care of your equipment](#)).
- ▶ Where the gang-form has panel struts and a pouring platform attached to it, fold in the side railing of this platform - attach gang-form to crane - only then detach the floor anchorages of the panel struts.

Ladder system

The Ladder system XS permits safe vertical access to and from the intermediate platforms and pouring platforms:

- when attaching/detaching the formwork to/from the crane tackle
- when opening/closing the formwork
- when placing the reinforcement
- during pouring

Note:

The ladder system must be implemented in such a way that all national regulations are complied with.



CAUTION

- ▶ The Ladders XS may only be used as part of the system, and must NOT be used separately (as 'lean-to' ladders).

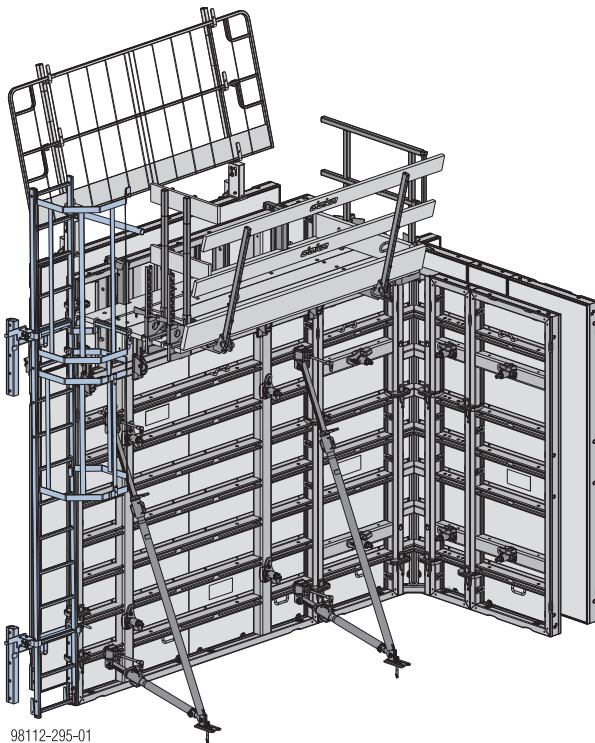

Assembly

Preparing the formwork

- ▶ Pre-assemble gang-forms face-down on a prepared flat area (see the section headed [Inter-panel connections](#)).
- ▶ Install platforms and panel struts on the laid-flat panel (see the sections headed [Pouring platforms](#) and [Plumbing accessories](#)).

Attaching connectors to the formwork

- ▶ Place the Connector XS wall formwork against the frame profile near the top of the formwork.
- ▶ Fasten the Connector XS wall formwork to the frame profile using two Quick acting clamps RU.

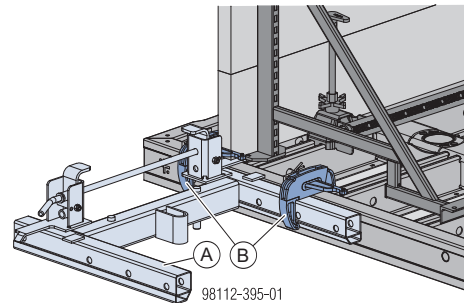

- A Connector XS wall formwork
- B Quick acting clamp RU

- ▶ Place a Connector XS wall formwork against the frame profile, near the bottom of the formwork.
- ▶ Fasten the Connector XS wall formwork to the frame profile using two Quick acting clamps RU.

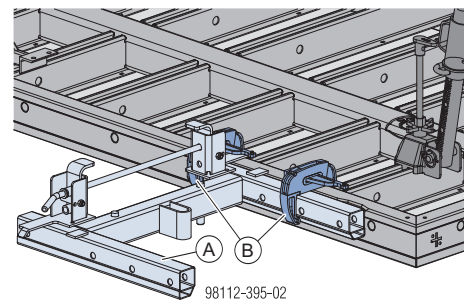

- A Connector XS wall formwork
- B Quick acting clamp RU

- ▶ For formwork heights above 5.85 m, an extra Connector XS wall formwork must be attached in the same way near the middle of the formwork (i.e. approx. half-way up). This prevents the ladder from swaying when site crew climb up or down.

Fixing the ladder

to the top Connector XS wall formwork

- ▶ Pull out the push-in pin, and pivot the two securing hooks out of the way.
- ▶ Place the System ladder XS 4.40m onto the Connector XS, with the hooking brackets facing downwards.
- ▶ Close the securing hooks.
- ▶ Insert the push-in pin into whichever rung of the ladder is suitable for the height of the formwork, and secure it with a linch pin.

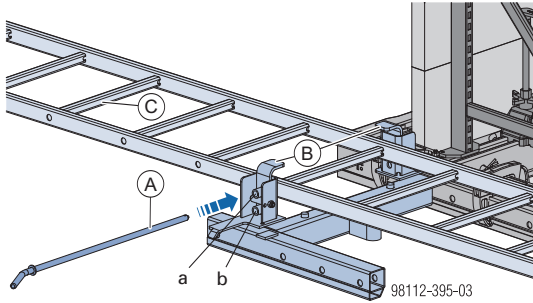

- in the frontmost position (a)

- A** Push-in pin
- B** Securing hook
- C** System ladder XS 4.40m

Animation:

<https://player.vimeo.com/video/274425011>

to the bottom Connector XS wall formwork

- ▶ Pull out the push-in pin, pivot both securing hooks out of the way, and place the ladder onto the Connector XS.
- ▶ Close the securing hooks, re-insert the push-in pin and secure it with a linch pin.

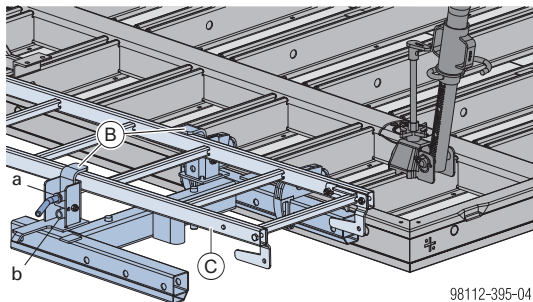

- in the frontmost position (a) for one single ladder
- in the rear position (b) in the telescoping zone (for 2 ladders)

- B** Securing hook
- C** Ladder XS

Animation:

<https://player.vimeo.com/video/274427263>

- ▶ Mount the Securing barrier XS to the ladder, with fixing hooks and wing-nuts.

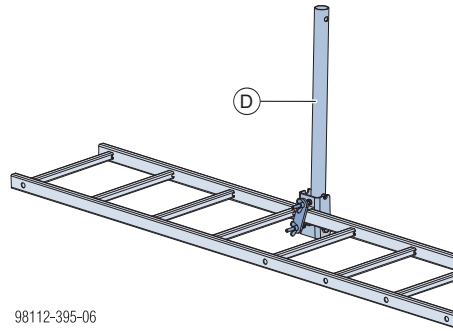

98112-395-06

D Securing barrier XS

The components needed for mounting the Securing barrier XS are captively attached to it.

Ladder system XS for heights above 3.75 m

Telescoping ladder extension (for adjusting to ground level)

- ▶ To telescope the ladders past one another, lift the safety latch on the ladder and fix the Ladder extension XS 2.30m onto the desired rung of the other ladder.

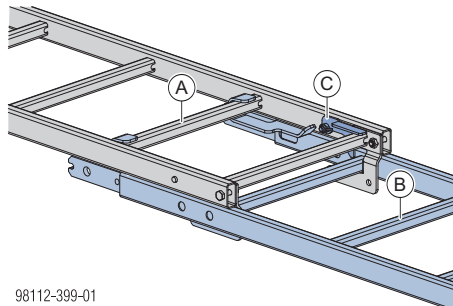

98112-399-01

Close-up

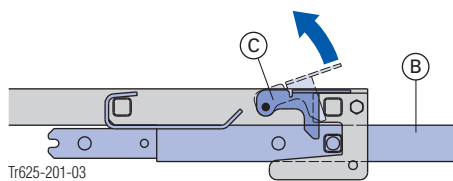

Tr625-201-03

- A** System ladder XS 4.40m
- B** Ladder extension XS 2.30m
- C** Safety latch

A telescoping joint between two Ladder extensions XS 2.30m can be made in the same way.

Permanently fixed ladder extension

- ▶ Insert the Ladder extension XS 2.30m into the uprights of the System ladder XS 4.40m, with its hooking brackets facing downwards, and fasten it. Tighten the screws only **slightly!**

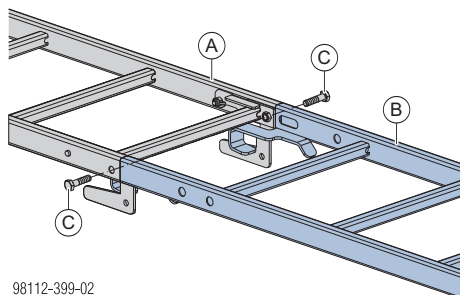

Bolts (C) are included in the scope of supply of the System ladder XS 4.40m and the Ladder extension XS 2.30m.

- A System ladder XS 4.40m
- B Ladder extension XS 2.30m
- C Hexagon bolt M10x40

Two Ladder extensions XS 2.30m can be fixed together in the same way.

**NOTICE**

- ▶ Always observe all relevant safety regulations applying to the use of the ladder cage in the country in which you are operating (e.g. in Germany: BGV D 36).
- ▶ Attach the Ladder cage exit XS (the bottom of the cage must always be at the same height as the platform). The safety latches prevent the cage from being accidentally lifted out.

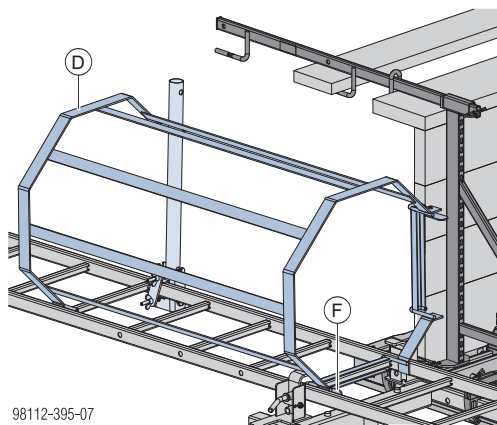

- D Ladder cage exit XS
- F Safety latch (anti-liftout guard)

- ▶ Attach the Ladder cage XS to the next available rung. Attach further ladder cages, in each case to the next available rung.

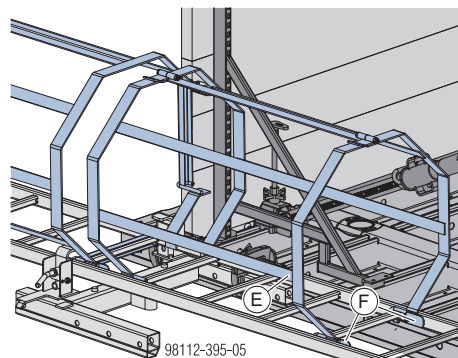

- E Ladder cage XS
- F Safety latches (anti-liftout guard)

Items needed

Connectors + ladder	Formwork height		
	2.70-3.75 m	>3.75-5.85 m	>5.85-8.10 m
Connector XS Wall formwork	2	2	3
Quick acting clamp RU or Fixing clamp XS Framax ¹⁾	4	4	6
System ladder XS 4.40m	1	1	1
Ladder extension XS 2.30m	0	1	2

¹⁾ When connected in the function profile

Ladder cage	Formwork height					
	2.70-3.15 m	>3.15-4.05 m	>4.05-5.40 m	>5.40-6.60 m	>6.60-7.65 m	>7.65-8.10 m
Ladder cage exit XS ²⁾	1	1	1	1	1	1
Securing barrier XS ²⁾	1	1	1	1	1	1
Ladder cage XS 1.00m ²⁾	0	1	2	3	4	5

²⁾ This does not take account of any intermediate exits.

Exit onto an intermediate platform

Note:

- The number of Connectors XS wall formwork and ladder components is shown in the table [Items needed](#).
- For each additional exit, one Ladder cage exit XS and one Securing barrier XS are required.
- Any over-large openings above the intermediate exit must be reduced with a Ladder cage XS 0.25m.

Mounting the Ladder cage XS 0.25m

- ▶ Hook the ladder cage into an empty rung and secure it against accidental lift-out.

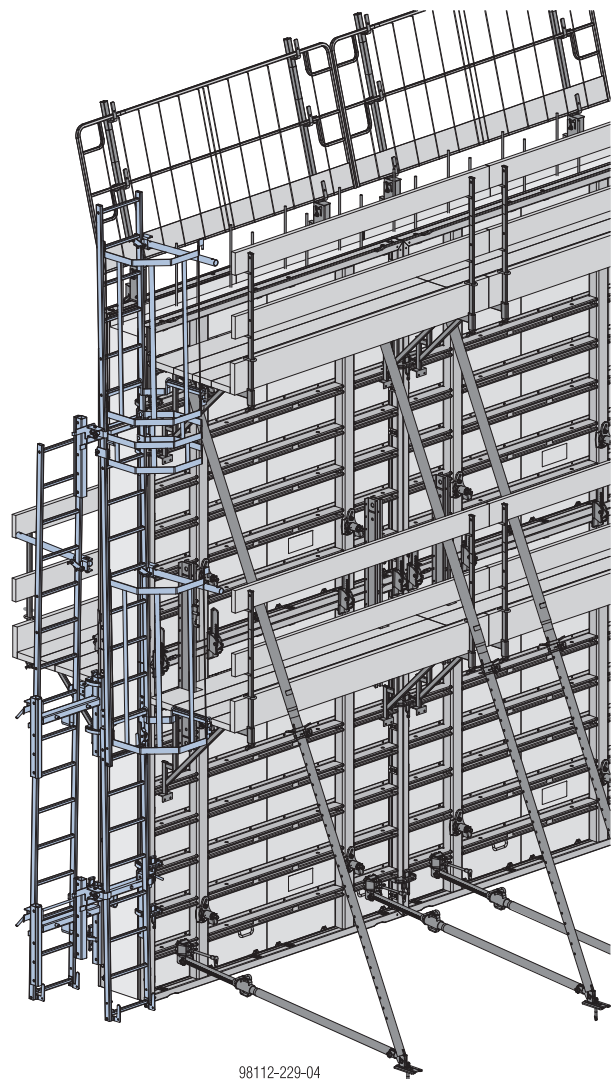
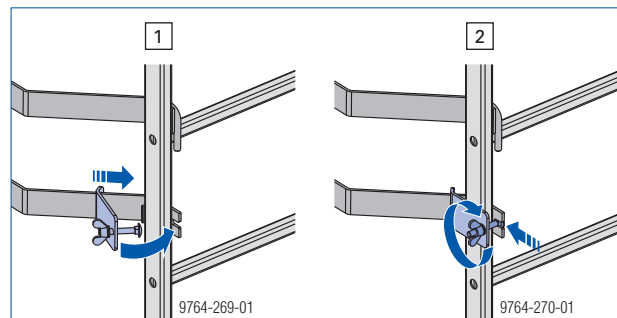

Tools for plumbing and aligning and for stripping the formwork



NOTICE

In preparation for plumbing and aligning or stripping, secure the panel or gang-form so that it cannot tip over (e.g. attach to the crane or secure with panel struts)

Framax positioning lever

The **Framax positioning lever** is a tool for plumbing and aligning the framed formwork and detaching the framed formwork from the hardened concrete.

Note:

Using the positioning lever to detach the formwork leaves impressions in the concrete. If impressions in the concrete are unacceptable: Use the Framax stripping tool!

- ▶ Engage the Framax positioning lever in the bottom-most cross borehole of the framed formwork.

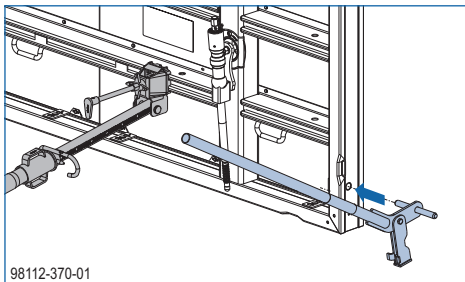

- ▶ Plumb and align the framed formwork or lever it away from the concrete, as applicable.

Plumbing and aligning the framed formwork:

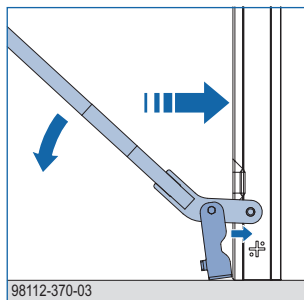
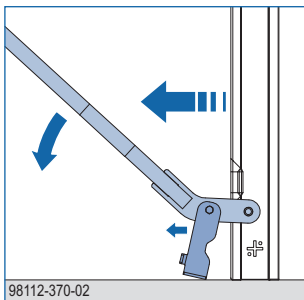

Detaching formwork from the concrete:

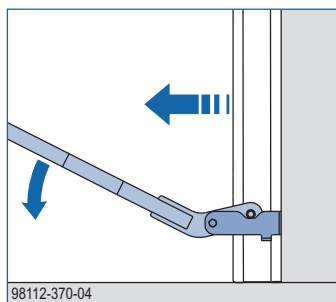

Framax stripping tool

The **Framax stripping tool** is for detaching the framed formwork from the hardened concrete.

- ▶ Position the Framax stripping tool into a cross bore-hole of the framed formwork.

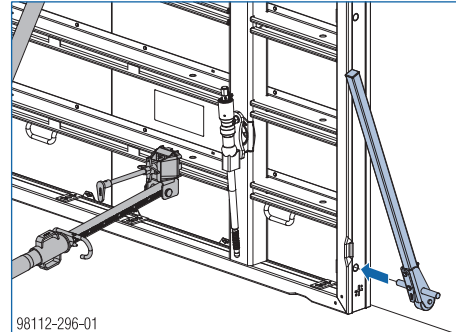

- ▶ Lever the framed formwork away from the concrete.

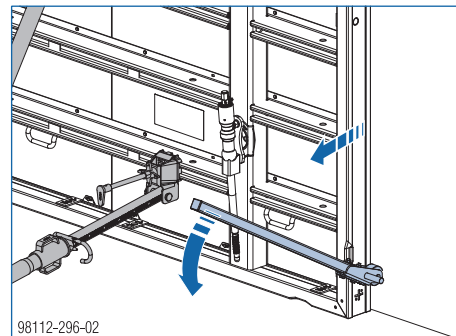

Framax stripping aid

The **Framax stripping aid** is for detaching a framed panel from the hardened concrete by pressing against the neighbouring panel.



NOTICE

- Disengage framed panel uniformly to avoid damaging the function profiles!
- Disengage framed panel approx. 6.0 cm from the concrete. This ensures that the panel cannot be trapped between the adjacent panels on each side on account of the profile geometry.

Start at topmost function profile **(1)**:

- ▶ Engage and position two Framax stripping aids in the function profile.

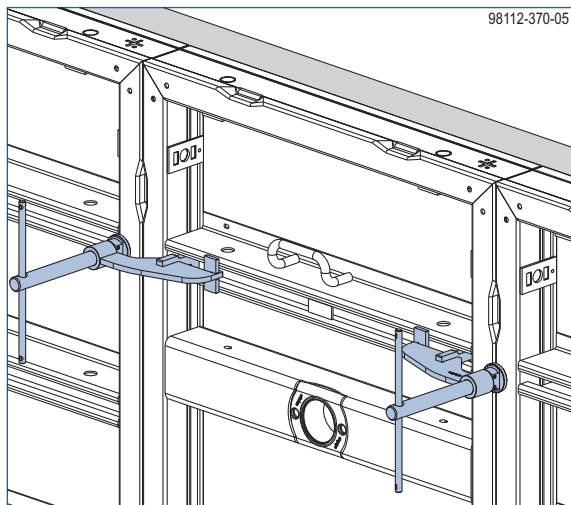

The spindles of the Framax stripping aids act against the frame profile of the neighbouring panel on each side.

- ▶ Detach the framed panel from the concrete by tightening both spindles at the same time.
- ▶ Repeat the operation at middle function profile **(2)** and then at the bottom function profile **(3)**.

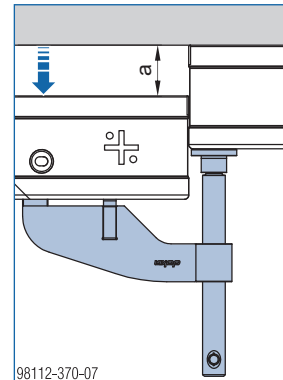
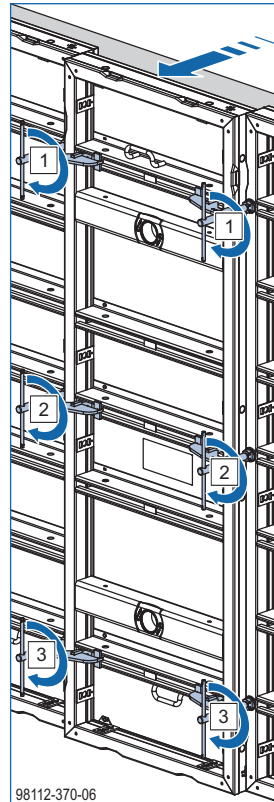

a ... approx. 6.0 cm

- ▶ Reposition the detached panel by crane.

Lifting by crane

Safe crane-handling of Framax Xlife plus is possible using the **Doka 4-part chain 3.20m** and the **Framax lifting hook**. The lifting hook locks automatically after being hung into place.

Doka 4-part chain 3.20m

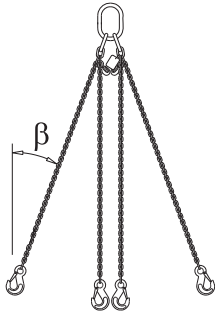

CE

- ▶ Attach the Doka 4-part chain 3.20m to the Framax lifting hooks.
- ▶ Hang the remaining chain-lengths back in place.

Permissible working load limit (2-part chain):
Up to 30° sling angle β 2400 kg.



Follow the Operating Instructions!

Framax lifting hook

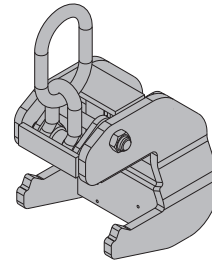

CE

Permissible working load limit:

- Sling angle β up to 30°:
1000 kg (2200 lbs) / Framax lifting hook
- Sling angle β up to 7.5°:
1500 kg (3300 lbs) / Framax lifting hook

Framax lifting hooks with permissible working load limit of 1000 kg (2200 lbs) also meet the requirements for a working load limit of 1500 kg (3300 lbs) max. using a sling angle $\beta \leq 7.5^\circ$.



Follow the Operating Instructions!



On larger gangs, use **Framax lifting hooks 25kN** or **Framax lifting hooks 20kN** together with a **two-part lifting chain with sufficient working load limit**.

Follow the directions in the 'Framax lifting hook 25kN' Operating Instructions!

Follow the directions in the 'Framax lifting hook 20kN' Operating Instructions!

Securing the lifting hooks against sliding from side to side



NOTICE

Position the lifting hooks so that they are secured against sideways slippage.

- over **inter-panel joints**
- over **cross profiles** (single panel installed on its side)
- over **centre profiles**
- over **welded-on metal plates**

For other suitable positions see the section headed [Position of the lifting hooks](#).

Position of the lifting hooks

Note:

The positions of the lifting hooks shown here also apply for vertically stacked gang-forms.

Single panel:

Panels up to 60cm wide

Panels over 60cm wide

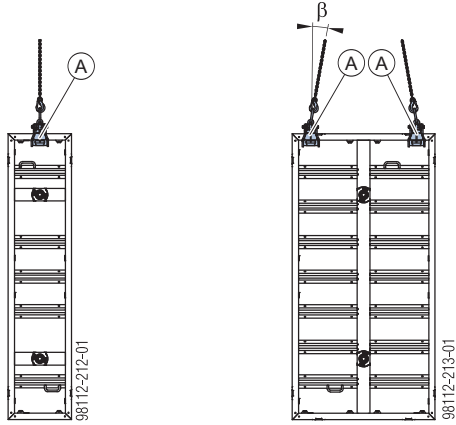

A Welded-on metal plate

Panel 2.70x2.70m / Panel 2.70x3.00m / Panel 2.70x3.30m

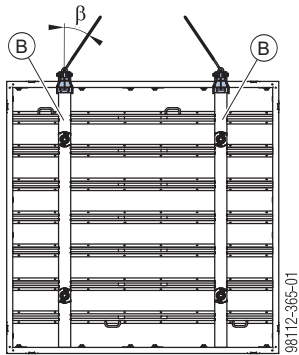

B Centre profile

Gang-form - two panels upright:

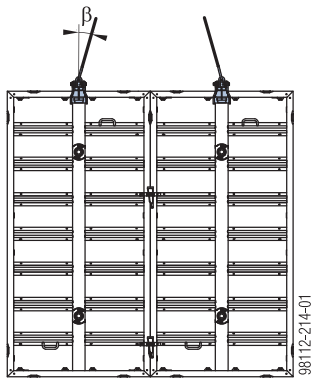

B Centre profile

Gang-form - three (or more) panels upright:

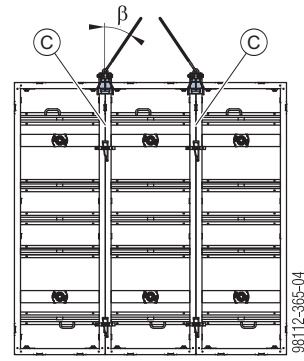

C Inter-panel joint

Gang-form - panel on its side (vertically stacked):

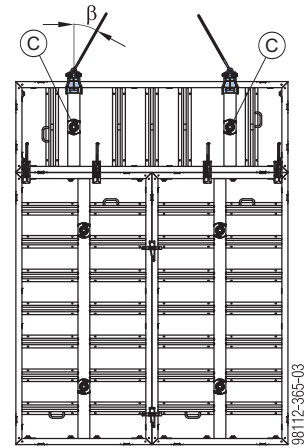

D Cross profile

Assembling tool

For operation of the lifting hook on upright formwork by operator on ground level.



CAUTION

Risk of the lifting hook falling when operated with assembling tool!

- ▶ With the crane, position the lifting hook level with the lifting point.

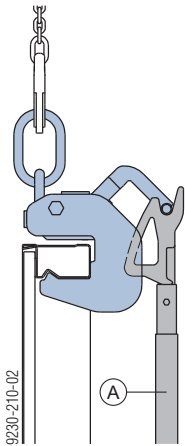

Formwork height

A Framax telescopic assembling tool (telescopes from 230 to 400 cm)	2.70 - 5.40m
Framax assembling tool	2.70 - 3.30m



In addition to operation of the lifting hook, the **Framax assembling tool** also offers the following functions:

- Pulling out double-headed nails
- Plumbing and aligning the formwork

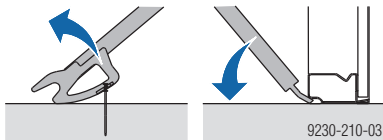

Transporting, stacking and storing

Bundling the Framax Xlife plus panels



NOTICE

Before stacking the panels, dismantle the Framax Xlife plus distance protectors NG.

- 1) Position sleepers measuring approx. 8.0 x 10.0 (W x H) underneath the cross profile.
- 2) Strap the sleepers (hardwood blocking) and the bottom panel together with metal banding.



WARNING

The smooth surface of the powder-coated panels reduces the sticking friction.

- ▶ It is strictly forbidden to lift stacks of panels without inserting Framax Xlife plus stacking cones (2 cones per layer) first!

Exception: Stacking cones are not required if the stack is lifted using the Framax transport gear.

- 3) Insert Framax Xlife plus stacking cones.

Max. number of panels in a stack:

Panel	Max. number of panels stacked on top of one another	Stacking height incl. sleepers
up to 1.35x2.70m	8	approx. 110 cm
2.70x2.70m	4	approx. 60 cm
up to 0.90x3.00m	8	approx. 110 cm
1.35x3.00m	8 *)	approx. 110 cm
2.70x3.00m	4	approx. 60 cm
up to 0.90x3.30m	8	approx. 110 cm
1.35x3.30m	5	approx. 75 cm
2.70x3.30m	4 *)	approx. 60 cm

*) Stack weight in excess of 2000 kg: Consequently, **Dokamatic lifting straps 13.00m** or **Framax transport bolts with Doka 4-part chain 3.20m** have to be used for lifting by crane.

Panels with Form-tie nuts I 20.0

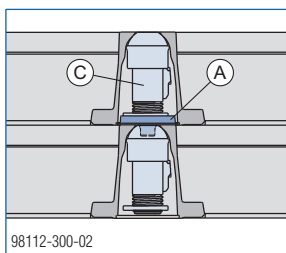

Panels with no form-tie nuts

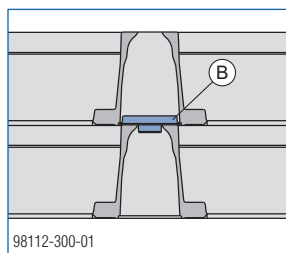

A Framax Xlife plus stacking cone I

B Framax Xlife plus stacking cone

C Framax Xlife plus form-tie nuts I 20.0

The stacking cones stop the panels slipping.

- 4) Strap the whole stack together tightly with strapping band.

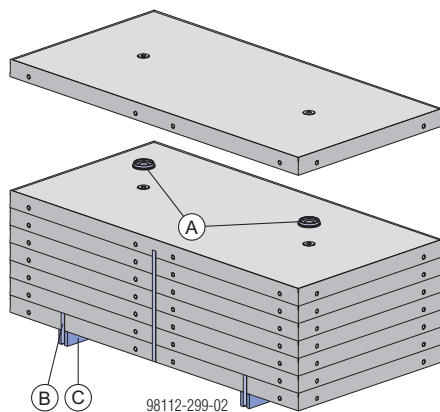

A Framax Xlife plus stacking cone or Framax Xlife plus stacking cone I

B Strapping band

C Sleeper

Transporting the Framax Xlife plus panels

Framax transport bolts with Doka 4-part chain 3.20m

The Framax transport bolts, in combination with the Doka 4-part chain 3.20m, are for hoisting individual stacks of panels and for separating the panels.

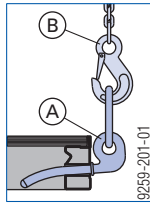

- A Framax transport bolt
- B Doka 4-part chain 3.20m

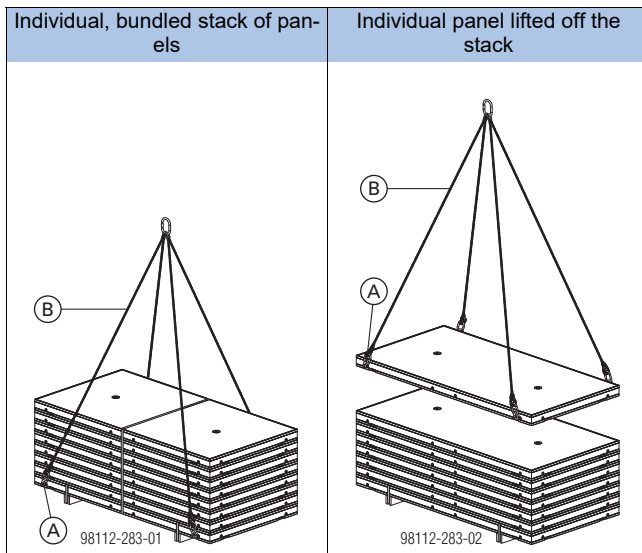

Framax transport bolt:

Permissible working load limit: 800 kg / transport bolt
 Framax transport bolts manufactured until 2015, with a stated working load limit of 500 kg, are also capable of a working load limit of 800 kg.

Follow the Operating Instructions!

Doka 4-part chain 3.20m

The Doka 4-part chain 3.20m is a multi-functional slinging means:

- used with the integrated **eye hooks** for hoisting formwork, platforms and multi-trip packaging containers.

For more information, see the section headed [Lifting by crane](#).

- used in conjunction with **Framax transport bolts** for hoisting individual stacks of panels and for separating the panels.

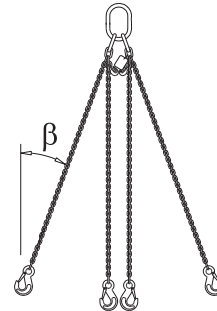

The Doka 4-part chain 3.20m can be adjusted to the centre-of-gravity position by shortening the length of individual chains.

Permissible working load limit:

	Sling angle β			
	0°	0°-30°	30°-45°	45°-60°
Using one chain	1400 kg	-	-	-
Using two chains	-	2400 kg	2000 kg	1400 kg
Using all four chains	-	3600 kg	3000 kg	2120 kg

Follow the Operating Instructions!

Dokamatic lifting strap 13.00m

The Dokamatic lifting strap 13.00m is a practical tool for **unloading and loading trucks**, and for **lifting and setting down individual stacks of panels**.

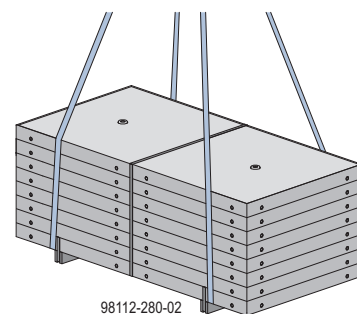

Dokamatic lifting strap 13.00m:

Permissible working load limit: 2000 kg / lifting strap

Follow the Operating Instructions!

Framax transport gear

For safe crane transport of individual stacks of panels at construction sites, depots etc.

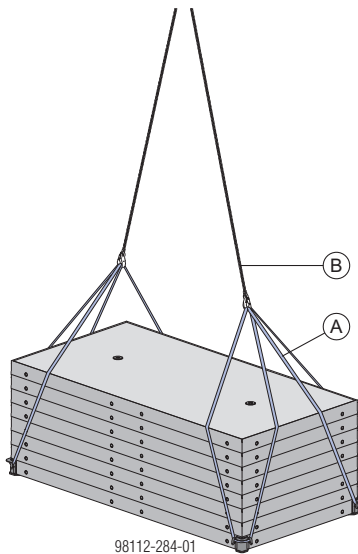

- A** Framax transport gear (consisting of 4 round slings)
- B** Chain suspension gear or Doka 4-part chain 3.20m

The four round slings of the transport gear hold the stack together on all four sides, in such a way that it is impossible for individual panels to slip out.

Benefits:

- Spring-loaded slinging hooks reach from underneath into the beads of the panel frame and prevent the transport gear accidentally detaching itself when the cable tension slackens.
- The automatic length compensation feature of the Framax transport gear ensures that the load is distributed evenly.
- The Framax transport gear can be suspended and detached by just one person working on their own.
- There is no need for anti-slippage protection using Framax Xlife plus stacking cones here.

Framax transport gear:

Permissible working load limit: 2000 kg/4 round slings



NOTICE

- The stacks must always be of panels of equal width.



Follow the Operating Instructions!

Lifting panels upright / turning panels over

- ▶ Use **Framax transport bolts** to lay the framed panel flat on squared timbers 20x20 cm

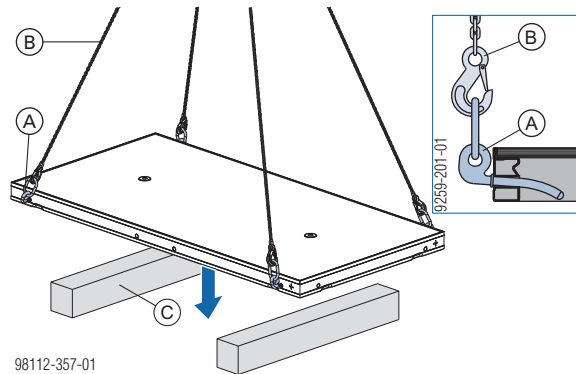

- A** Framax transport bolt
- B** Doka 4-part chain 3.20m
- C** Squared timber 20x20 cm



WARNING

Using Framax transport bolts to lift the framed panels upright or turn them over is prohibited!

- ▶ Use Framax lifting hooks!

- ▶ Position the Framax lifting hooks. Lift the framed panel upright with **Framax lifting hooks** and, if applicable, lay it flat with the sheeting side down.

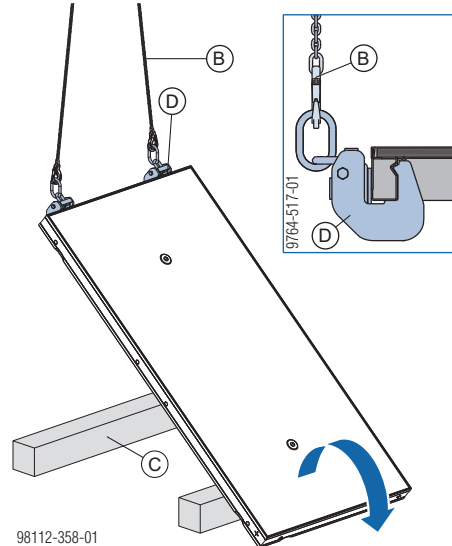

- B** Doka 4-part chain 3.20m
- C** Squared timber 20x20 cm
- D** Framax lifting hook



Follow the Operating Instructions!

Doka skeleton transport box 1.70x0.80m

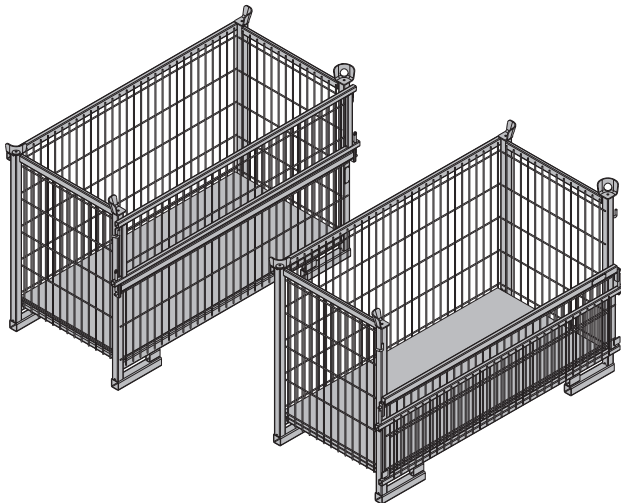

Storage and transport device for small items. To make the Doka skeleton transport box easier to load and unload, one of its sidewalls can be opened.

Permitted load-bearing capacity: 700 kg (1540 lbs)
 Permitted imposed stacking load: 3150 kg (6950 lbs)

Using Doka skeleton transport boxes 1.70x0.80m as storage units

Max. n° of units on top of one another

Outdoors (on the site) Floor gradients up to 3%	Indoors Floor gradients up to 1%
2	5
It is not allowed to stack empty pallets on top of one another!	



NOTICE

Stacked multi-trip boxes or pallets must have the heaviest boxes at the bottom and the lightest at the top.

Using Doka skeleton transport boxes 1.70x0.80m as transport devices

Lifting by crane



NOTICE

- Multi-trip packaging items must be lifted individually.
- Only lift the boxes when their sidewalls are closed!
- Use suitable lifting chains:
 - e.g. Doka 4-part chain 3.20m
 - Do not exceed the permitted working load limit of the lifting chains.
- Sling angle β max. 30°!

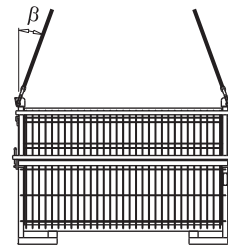

9234-203-01

Repositioning by forklift truck or pallet stacking truck

The forks can be inserted under either the broadside or the narrowside of the containers.

Doka multi-trip transport box

Storage and transport device for small items

Doka multi-trip transport box 1.20x0.80m

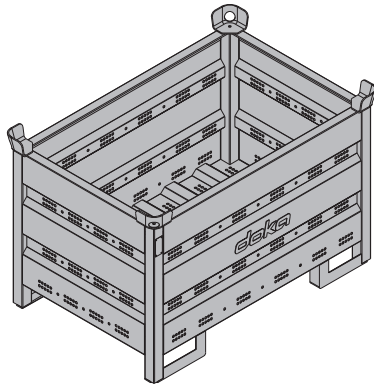

Permitted load-bearing capacity: 1500 kg (3300 lbs)
Permitted imposed stacking load: 7850 kg (17300 lbs)

Different items in the Doka multi-trip transport box can be kept separate with the **Multi-trip transport box partitions 1.20m or 0.80m**.

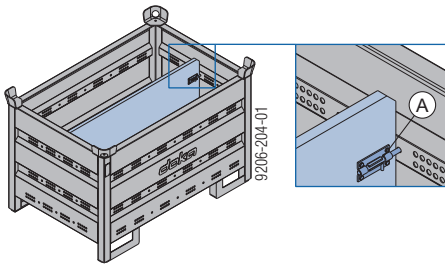

A Slide-bolt for fixing the partition

Possible ways of dividing the box

Multi-trip transport box partition	in the longitudinal direction	in the transverse direction
1.20m	max. 3	-
0.80m	-	max. 3

<p>9206-204-02</p>	<p>9206-204-03</p>
--------------------	--------------------

Doka multi-trip transport box 1.20x0.80mx0.41m

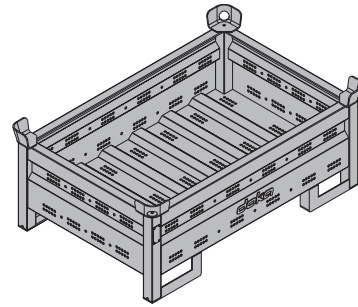

Permitted load-bearing capacity: 750 kg (1650 lbs)
Permitted imposed stacking load: 7200 kg (15870 lbs)

Using Doka multi-trip transport boxes as storage units

Max. n° of units on top of one another

Outdoors (on the site)		Indoors	
Floor gradients up to 3%		Floor gradients up to 1%	
Doka multi-trip transport box 1.20x0.80m	Doka multi-trip transport box 1.20x0.80x0.41m	Doka multi-trip transport box 1.20x0.80m	Doka multi-trip transport box 1.20x0.80x0.41m
3	5	6	10
It is not allowed to stack empty pallets on top of one another!			



NOTICE

Stacked multi-trip boxes or pallets must have the heaviest boxes at the bottom and the lightest at the top.

Using Doka multi-trip transport boxes as transport devices

Lifting by crane



NOTICE

- Multi-trip packaging items must be lifted individually.
- Use suitable lifting chains:
 - e.g. Doka 4-part chain 3.20m
 - Do not exceed the permitted working load limit of the lifting chains.
- Sling angle β max. 30°!

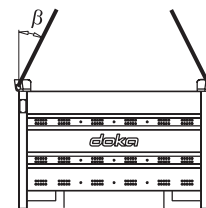

9206-202-01

Repositioning by forklift truck or pallet stacking truck

The forks can be inserted under either the broadside or the narrowside of the containers.

Doka stacking pallet 1.55x0.85m and 1.20x0.80m

Storage and transport device for long items.

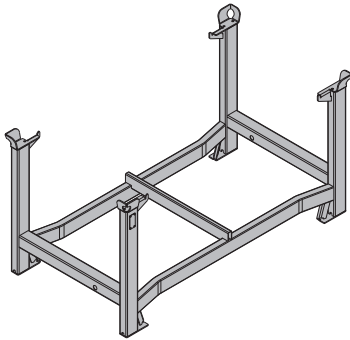

Permitted load-bearing capacity: 1100 kg (2420 lbs)
 Permitted imposed stacking load: 5900 kg (13000 lbs)

Using Doka stacking pallets as storage units

Max. number of units on top of one another

Outdoors (on the site) Floor gradients up to 3%	Indoors Floor gradients up to 1%
2	6
It is not allowed to stack empty multi-trip boxes or pallets on top of one another!	



NOTICE

- Stacked multi-trip boxes or pallets must have the heaviest boxes at the bottom and the lightest at the top!
- Castor wheels or bolt-on castor sets must not be fitted to the bottom multi-trip packaging in the stack.
- Secure multi-trip packagings with installed castor wheels using the fixing brake when parking.

Using Doka stacking pallets as transport devices

Lifting by crane



NOTICE

- Multi-trip packaging items must be lifted individually.
- Use suitable lifting chains:
 - e.g. Doka 4-part chain 3.20m
 - Do not exceed the permitted working load limit of the lifting chains.
- Load the items centrally.
- Fasten the load to the stacking pallet (e.g. with strapping tape or lashing strap) so that it cannot slide or tip out.
- Sling angle β max. 30°!

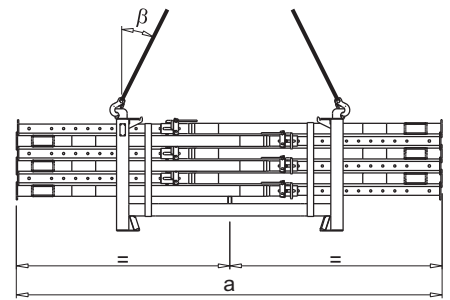

92815-224-01

	a
Doka stacking pallet 1.55x0.85m	max. 4.5 m
Doka stacking pallet 1.20x0.80m	max. 3.0 m

Repositioning by forklift truck or pallet stacking truck



NOTICE

- Load the items centrally.
- Fasten the load to the stacking pallet (e.g. with strapping tape or lashing strap) so that it cannot slide or tip out.

Doka accessory box

Storage and transport device for small items.

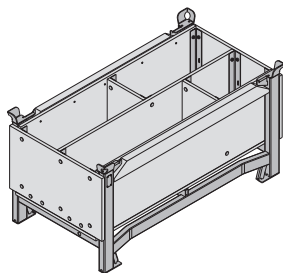

Permitted load-bearing capacity: 1000 kg (2200 lbs)
 Permitted imposed stacking load: 5530 kg (12190 lbs)

Doka accessory boxes as storage units

Max. number of units on top of one another

Outdoors (on the site) Floor gradients up to 3%	Indoors Floor gradients up to 1%
3	6
It is not allowed to stack empty multi-trip boxes or pallets on top of one another!	



NOTICE

- Stacked multi-trip boxes or pallets must have the heaviest boxes at the bottom and the lightest at the top!
- Castor wheels or bolt-on castor sets must not be fitted to the bottom multi-trip packaging in the stack.
- Secure multi-trip packagings with installed castor wheels using the fixing brake when parking.

Doka accessory box as transport devices

Lifting by crane



NOTICE

- Multi-trip packaging items must be lifted individually.
- Use suitable lifting chains:
 - e.g. Doka 4-part chain 3.20m
 - Do not exceed the permitted working load limit of the lifting chains.
- When lifting units to which Bolt-on castor sets B have been attached, you must also follow the directions in the 'Bolt-on castor set B' User information booklet!
- Sling angle β max. 30°!

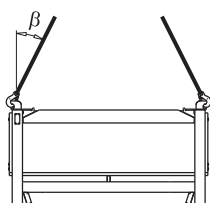

92816-206-01

Repositioning by forklift truck or pallet stacking truck

The forks can be inserted under either the broadside or the narrowside of the containers.

Universal castor wheel for transport pallet

The Universal castor wheel for transport pallet turns multi-trip packaging items into fast and manoeuvrable transport devices.

- 4 castor wheels needed per multi-trip packaging item.
- Compatible multi-trip packaging items:
 - Doka stacking pallets (all sizes)
 - Doka multi-trip transport box 1.20x0.80m
 - Doka skeleton transport box 1.70x0.80m
 - DokaXdek panel pallets (all sizes)
 - Superdek beam pallet 1.22x1.10m



Follow the directions in the 'Universal castor wheel for transport pallet' User Information booklet.

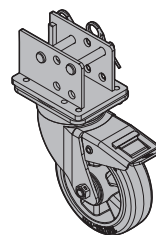

Bolt-on castor set B

The Bolt-on castor set B turns multi-trip packaging items into fast and manoeuvrable transport devices.

- Suitable for drive-through access openings > 90 cm.
- Compatible multi-trip packaging items:
 - Doka accessory box
 - Doka stacking pallets (all sizes)
 - Protective barrier Z pallets



Follow the directions in the 'Bolt-on castor set B' User Information booklet!

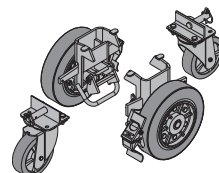

General

Areas of use

Bottom joist

Framax Xlife plus panel (on its side)	Number of Framax head anchors
1.35x3.30m	3
1.35x3.00m	3
0.30 up to 0.90x3.30m	2
0.30 up to 0.90x3.00m	2
0.30 up to 1.35x2.70m	2

Framax Xlife plus panel (upright)	Number of Framax head anchors
1.35x1.35m	1
0.30 up to 0.90x1.35m	1*

* ... only at every second panel

Framax head anchor:

Permitted tensile force: 10 kN
Permitted compressive force: 10 kN

Note:

For directions on installing the Framax head anchor see the section headed [Framax head anchor 15-40cm](#).

Example with 0.90x2.70m panel

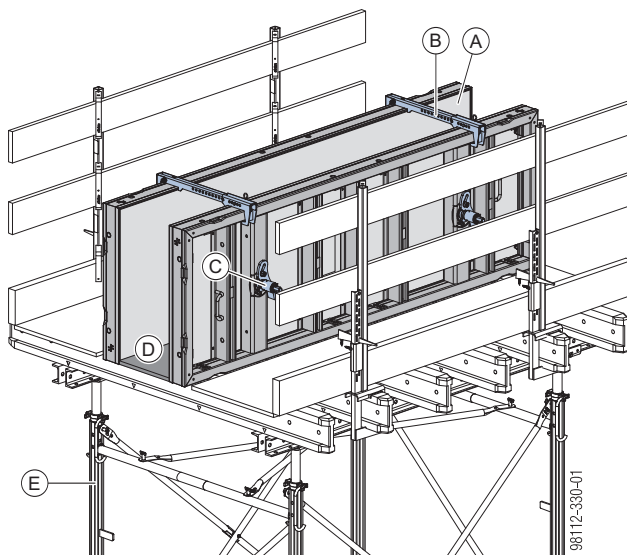

Shown here without ladderways.

- A Framax Xlife plus panel 0.90x2.70m
- B Framax head anchor
- C Tie rod system Framax Xlife plus
- D Formwork sheet
- E Load-bearing tower (e.g. Staxo eco)

Foundation formwork

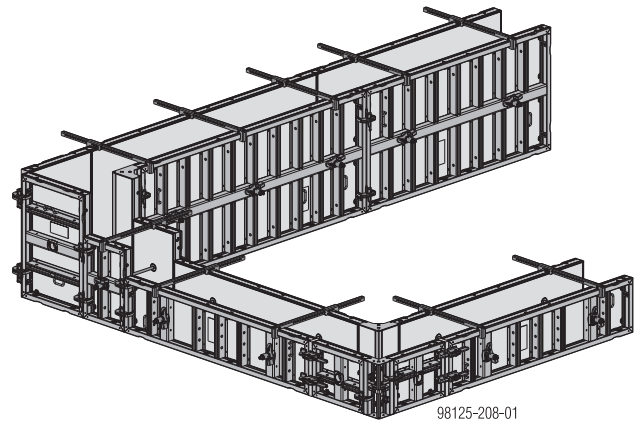

Follow the directions in the 'Foundation formwork Framax Xlife plus' User Information booklet.

Forming self-compacting concrete (SCC)

The **Framax Xlife universal panel SCC** and the **Universal panel SCC 0.45x1.50m** enable the placement of self-compacting concrete (SCC).



NOTICE

The connection point for self-compacting concrete (SCC) is not suitable for pouring conventional concrete!



Follow the directions in the 'Forming self-compacting concrete (SCC)' User Information booklet.

Framax Xlife plus combined with . . .

Climbing formwork MF240

Climbing formwork MF240 proves its versatility on all tall structures. The formwork and climbing scaffold are linked together as a single unit which can be repositioned in one single crane cycle.

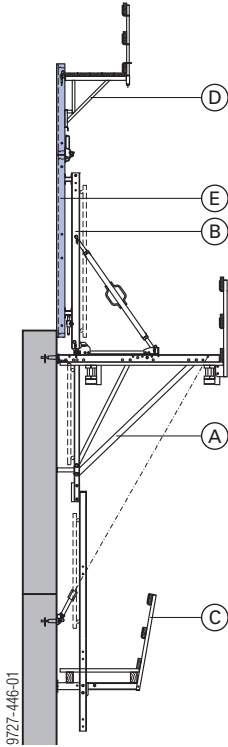

- A Climbing bracket MF240
- B Travelling unit MF
- C Suspended platform MF75 5.00m
- D Framax bracket 90
- E Framax Xlife plus panel



Follow the directions in the 'Climbing formwork MF240' User Information booklet!

Doka automatic climbing formwork

With their modular design concept, these crane-independent automatic climbing formwork systems provide an efficient solution for every type of structure.

The formwork and climbing scaffold are linked together as a single unit which can be lifted and reset hydraulically.



Follow the directions in the relevant User Information booklet.

Doka folding platforms

The high capacity of these working and safety scaffolds means that the formwork can safely be stood on the folding platforms.

Adding a few standard parts converts a working platform into a climbing formwork unit which can be shifted as a complete form and access-platform in one single operation.

This makes work at great heights faster and more efficient.

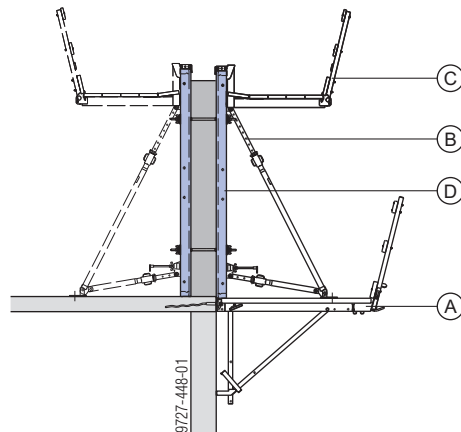

- A Doka folding platform
- B Panel strut
- C Framax pouring platform
- D Framax Xlife plus panel



Follow the directions in the "Folding platform K" and "Climbing formwork K" User Information booklets!

Doka supporting construction frames

The Doka supporting construction frames also enable the sturdy Framax Xlife plus panels to be used as single-sided wall formwork.

Supporting construction frame "Variable"

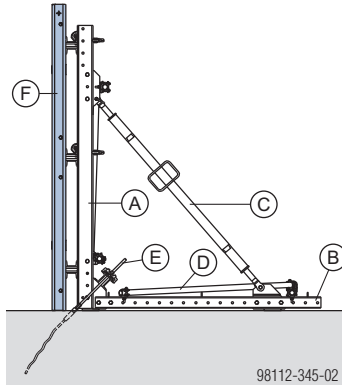

- A Waling WU14 for supporting construction frame
- B Multi-purpose walings WS10 Top50 2.00m
- C Spindle strut 12 3.00m
- D Bracing
- E Tension anchoring
- F Framax Xlife plus panel



Follow the directions in the 'Supporting construction frame "Variable" User Information booklet.

Supporting construction frame "Universal"

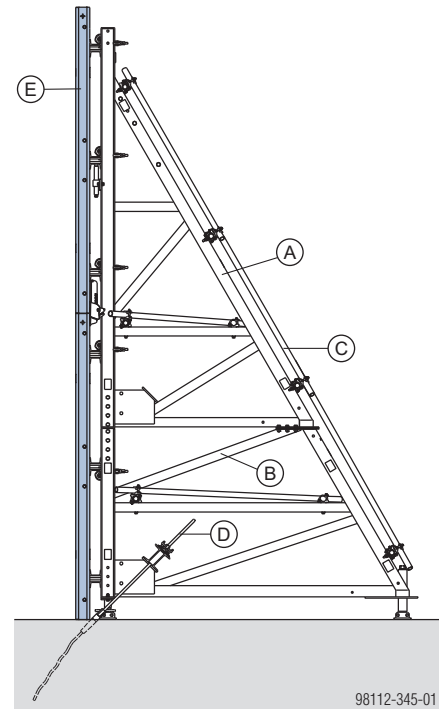

- A Supporting construct. frame Universal F 4.50m
- B Attachable frame F 1.50m
- C Bracing
- D Tension anchoring
- E Framax Xlife plus panel



Follow the directions in the 'Supporting construction frame "Universal" User Information booklet.

Cleaning and care of your equipment

Release agents

Doka-Trenn and Doka-OptiX are applied using the Doka release-agent sprayer.

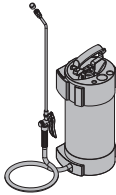

Follow the directions in the 'Doka release-agent sprayer' Operating Instructions and on the containers of release agent.



NOTICE

- Before every pour:
 - Apply release agent to the formwork sheet and the end faces **extremely thinly, evenly and in a continuous layer**.
- Make sure there are no drips of release-agent running down the formwork sheet.
- Applying too much release agent will spoil the concrete finish.



To determine the right dosage and to make sure that you are using the agent correctly, test it on less important parts of the structure first.

Cleaning



NOTICE

- Immediately after pouring:
 - Remove any blobs of concrete from the back-face of the formwork, using water (without any added sand).
- Immediately after stripping the formwork:
 - Clean the formwork with a high-pressure washer and a concrete scraper.
- Do not use any chemical cleaning agents!

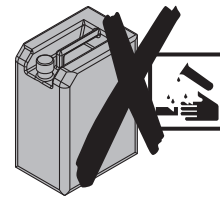

Cleaning high formwork:

Provide a service tower at a suitable cleaning location.

- Wheel-around scaffold DF (working heights of up to 3.50 m)
- Ringlock (working heights of up to 12.00 m)

Cleaning equipment

High-pressure spray cleaner



NOTICE

- Appliance pressure rating: 200 to max. 300 bar
- Keep the water-jet the correct distance from the formwork, and move it at the right speed:
 - The higher the pressure, the further away from the formwork you must keep the jet and the faster you must move it across the surface.
- Do not aim the jet at one place for too long.
- Make only moderate use of the jet around the silicone sealing strip:
 - If the pressure is too high, this will damage the silicone sealing strip.
 - Do not aim the jet at one place for too long.

Concrete scraper

For removing any concrete remnants, we recommend using a **Double scraper Xlife** and a spatula.

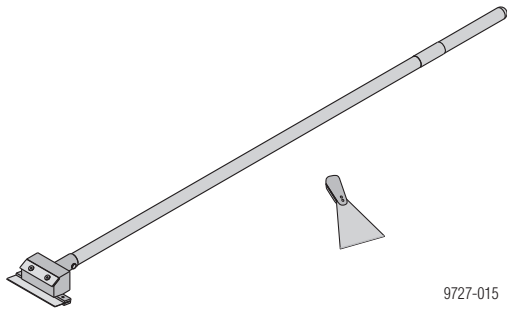

9727-015

Functional description:

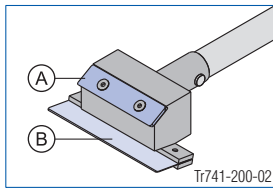

Tr741-200-02

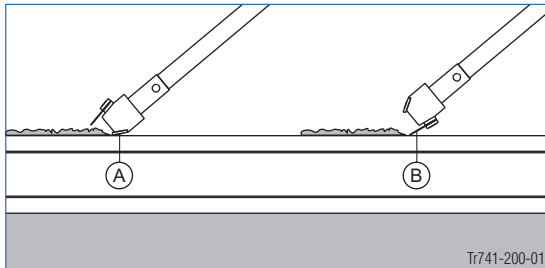

Tr741-200-01

- A Blade for dealing with heavy soiling
- B Blade for dealing with slight soiling



NOTICE

Do not use pointed or sharp objects, wire brushes, abrasive disks or cup brushes.

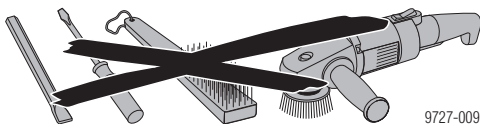

9727-009

Anchoring-sleeve cleaner

Clean the form-tie sleeve with the Framax Xlife plus anchoring sleeve cleaner.

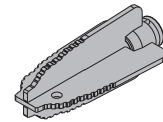

- ▶ Snap the anchoring sleeve cleaner on to the Framax Xlife plus ratchet and turn the cleaner in the sleeve.

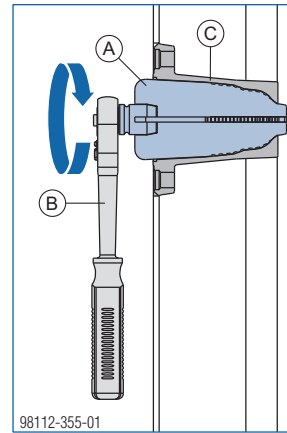

98112-355-01

- A Framax Xlife plus anchoring-sleeve cleaner
- B Framax Xlife plus ratchet 1/2" SW24 L
- C Form-tie sleeve inside the Framax Xlife plus panel



NOTICE

Do not use with an impact wrench! That can cause damage to the form-tie sleeve.

Care

- No hammer-blows to the frame profiles

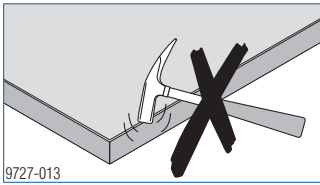

- Do not use nails on the formwork that are longer than 60 mm

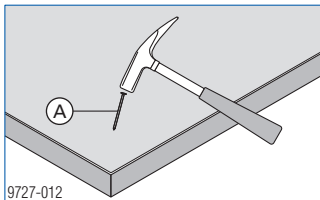

A max. l=60 mm

- Never push over panels or allow them to fall

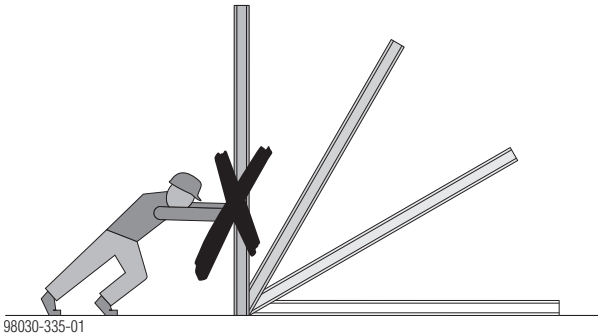

- Only stack panel gangs on top of one another with timber battens (**A**) between each layer.

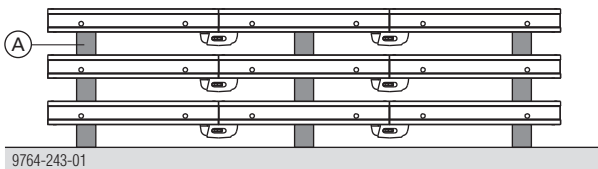

This prevents the formwork sheets from being damaged by the connector components.

Fall protection on the structure

Xsafe edge protection XP

- Attached with screw-on shoe, railing clamp, hand-rail-post shoe or Step bracket XP
- Protective grating XP, guardrail boards or scaffold tubes can be used as the safety barrier

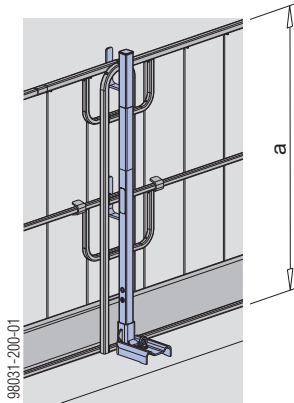

a ... > 1.00 m



Follow the directions in the 'Xsafe edge protection XP' User Information booklet.

Handrail clamp S

- Attached with integral clamp
- Guard-rail boards or scaffold tubes can be used as the safety barrier

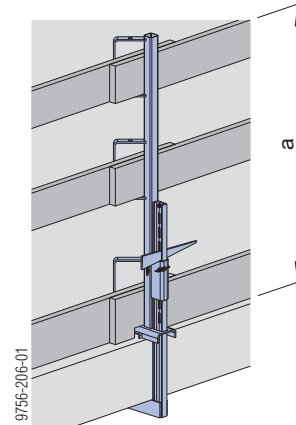

a ... > 1.00 m



Follow the directions in the "Handrail clamp S" User information!

Xsafe edge protection Z

- Attachment by integral screw-on shoe
- Protective barrier Z can be used as the safety barrier

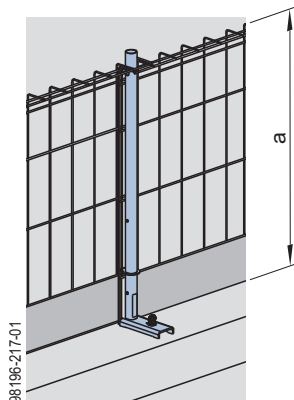

a ... > 1.17 m



Follow the directions in the 'Xsafe edge protection Z' User Information booklet.

Handrail post 1.10m

- Fixed in a Screw sleeve 20.0 or Attachable sleeve 24mm
- Guard-rail boards or scaffold tubes can be used as the safety barrier

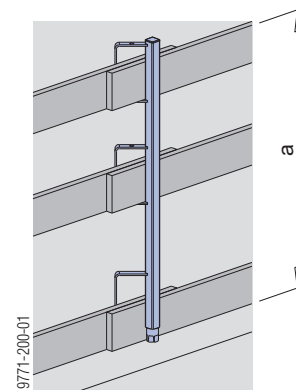

a ... > 1.00 m



Follow the directions in the 'Handrail post 1.10m' User Information!

	[kg]	Article N°
Framax Xlife plus panel 2.70x3.30m	521.5	589290600
Framax Xlife plus panel 1.35x3.30m	273.0	589291600
Framax Xlife plus panel 0.90x3.30m	196.6	589292600
Framax Xlife plus panel 0.75x3.30m	174.7	589293600
Framax Xlife plus panel 0.60x3.30m	137.7	589294600
Framax Xlife plus panel 0.55x3.30m	128.3	589330600
Framax Xlife plus panel 0.50x3.30m	121.2	589331600
Framax Xlife plus panel 0.45x3.30m	114.5	589295600
Framax Xlife plus panel 0.30x3.30m	91.5	589296600
Framax Xlife plus-Element 3,30m		



Galvanised
Powder-coated grey
Custom sizes on enquiry!

	[kg]	Article N°
Framax Xlife plus panel 1.35x1.35m	114.0	589267600
Framax Xlife plus panel 0.90x1.35m	78.3	589268000
Framax Xlife plus panel 0.75x1.35m	71.0	589269000
Framax Xlife plus panel 0.60x1.35m	57.5	589270000
Framax Xlife plus panel 0.55x1.35m	53.0	589334000
Framax Xlife plus panel 0.50x1.35m	49.8	589335000
Framax Xlife plus panel 0.45x1.35m	46.0	589271000
Framax Xlife plus panel 0.30x1.35m	35.5	589272000
Framax Xlife plus-Element 1,35m		

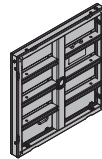

Galvanised
Powder-coated grey
Custom sizes on enquiry!

Framax Xlife plus panel 2.70x3.00m	480.0	589350000
Framax Xlife plus panel 1.35x3.00m	252.0	589352000
Framax Xlife plus panel 0.90x3.00m	182.3	589353000
Framax Xlife plus panel 0.75x3.00m	158.6	589354000
Framax Xlife plus panel 0.60x3.00m	119.8	589355000
Framax Xlife plus panel 0.55x3.00m	110.2	589356000
Framax Xlife plus panel 0.50x3.00m	103.5	589357000
Framax Xlife plus panel 0.45x3.00m	98.5	589358000
Framax Xlife plus panel 0.30x3.00m	77.0	589359000
Framax Xlife plus-Element 3,00m		



Galvanised
Powder-coated grey
Custom sizes on enquiry!

Framax Xlife plus panel 0.90x0.60m	42.8	589313000
Framax Xlife plus panel 0.75x0.60m	38.8	589314000
Framax Xlife plus panel 0.60x0.60m	33.0	589315000
Framax Xlife plus panel 0.55x0.60m	27.5	589336000
Framax Xlife plus panel 0.50x0.60m	26.2	589337000
Framax Xlife plus panel 0.45x0.60m	24.5	589316000
Framax Xlife plus panel 0.30x0.60m	18.4	589317000
Framax Xlife plus-Element 0,60m		



Galvanised
Powder-coated grey
Custom sizes on enquiry!

Framax Xlife plus panel 2.70x2.70m	435.5	589260600
Framax Xlife plus panel 1.35x2.70m	222.5	589261600
Framax Xlife plus panel 0.90x2.70m	163.7	589262600
Framax Xlife plus panel 0.75x2.70m	145.0	589263600
Framax Xlife plus panel 0.60x2.70m	110.1	589264600
Framax Xlife plus panel 0.55x2.70m	95.0	589332600
Framax Xlife plus panel 0.50x2.70m	93.6	589333600
Framax Xlife plus panel 0.45x2.70m	90.5	589265600
Framax Xlife plus panel 0.30x2.70m	69.5	589266600
Framax Xlife plus-Element 2,70m		



Galvanised
Powder-coated grey
Custom sizes on enquiry!

Framax Xlife plus panel C 2.70x3.30m	521.5	589290000
Framax Xlife plus panel C 1.35x3.30m	273.0	589291000
Framax Xlife plus panel C 0.90x3.30m	196.6	589292500
Framax Xlife plus panel C 0.75x3.30m	174.7	589293500
Framax Xlife plus panel C 0.60x3.30m	137.7	589294500
Framax Xlife plus panel C 0.55x3.30m	128.3	589330500
Framax Xlife plus panel C 0.50x3.30m	121.2	589331500
Framax Xlife plus panel C 0.45x3.30m	114.5	589295500
Framax Xlife plus panel C 0.30x3.30m	89.3	589296500
Framax Xlife plus panel C 2.70x2.70m	435.5	589260000
Framax Xlife plus panel C 1.35x2.70m	222.5	589261000
Framax Xlife plus panel C 0.90x2.70m	151.0	589262000
Framax Xlife plus panel C 0.75x2.70m	135.5	589263000
Framax Xlife plus panel C 0.60x2.70m	107.0	589264000
Framax Xlife plus panel C 0.55x2.70m	96.0	589332000
Framax Xlife plus panel C 0.50x2.70m	93.6	589333000
Framax Xlife plus panel C 0.45x2.70m	87.0	589265000
Framax Xlife plus panel C 0.30x2.70m	67.5	589266000
Framax Xlife plus panel C 1.35x1.35m	114.0	589267000
Framax Xlife plus-Element		











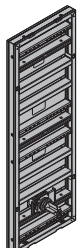
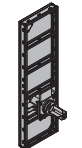
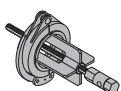

Galvanised, powder-coated
manufactured between 2019 and
2021

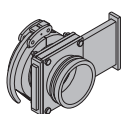

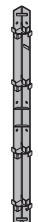

Framax Xlife plus panel B 0.90x3.30m	215.0	589292000
Framax Xlife plus panel B 0.75x3.30m	193.3	589293000
Framax Xlife plus panel B 0.60x3.30m	140.6	589294000
Framax Xlife plus panel B 0.45x3.30m	113.9	589295000
Framax Xlife plus panel B 0.30x3.30m	88.5	589296000









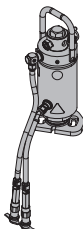

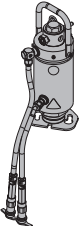

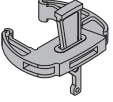
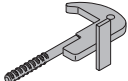
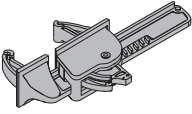
Galvanised, powder-coated
manufactured between 2015 and
2021

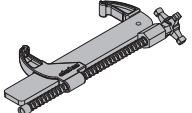
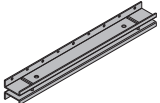

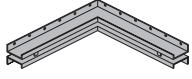
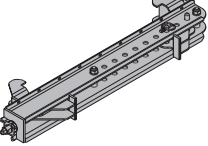
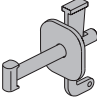

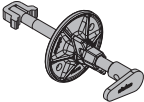
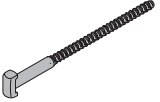

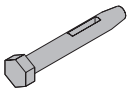
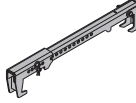

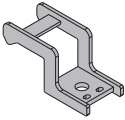
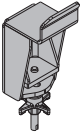
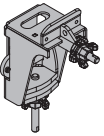
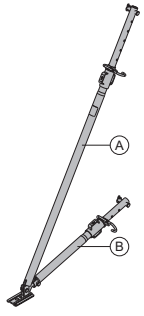
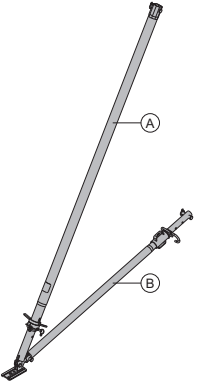
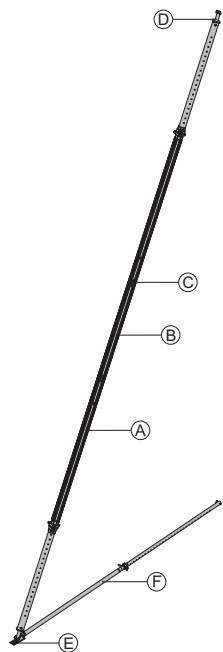
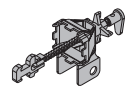
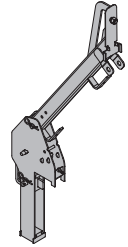
	[kg]	Article N°		[kg]	Article N°
Framax Xlife plus frame hole plug 32mm NG Framax Xlife plus-Ankerstopfen 32mm NG Black Diameter: 3.5 cm	0.004	589280500		Frami tie-adapter for stripping corner I Frami-Ankeradapter für Ausschalecke I Galvanised Height: 11 cm	0.47 588492000
Framax Xlife universal panel 0.90x3.30m Framax Xlife universal panel 0.90x2.70m Framax Xlife universal panel 0.90x1.35m	182.6 148.0 79.3	588228500 588122500 588124500		Frami profile adapter for stripping corner I Frami-Profiladapter für Ausschalecke I Galvanised Height: 8 cm	0.6 588491000
Framax Xlife plus universal panel 0.90x3.00m Framax Xlife plus-Uni-Element 0,90x3,00m Galvanised Powder-coated grey	178.5	589368000		Framax Xlife plus inside corner 30/30cm 3.30m Framax Xlife plus inside corner 30/30cm 3.00m Framax Xlife plus inside corner 30/30cm 2.70m Framax Xlife plus inside corner 30/30cm 1.35m Framax Xlife plus-Innenecke 30/30cm Galvanised Powder-coated grey	123.0 102.0 95.5 53.3 26.4 589299600 589360000 589239600 589240600 589318000
Framax Xlife universal panel SCC 0.90x2.70m Framax Xlife-Uni-Element SCC 0,90x2,70m Galvanised, powder-coated	170.3	588119500		Framax Xlife plus ins. corner C 30/30cm 3.30m Framax Xlife plus ins. corner C 30/30cm 2.70m Framax Xlife plus ins. corner C 30/30cm 1.35m Galvanised, powder-coated manufactured between 2015 and 2021	126.0 95.5 51.0 589299000 589239000 589240000
Universal panel SCC 0.45x1.50m Uni-Element SCC 0,45x1,50m Galvanised, powder-coated	47.5	589446000		Framax Xlife inside corner 3.30m Framax Xlife inside corner 2.70m Framax Xlife inside corner 1.35m Framax Xlife-Innenecke Galvanised, powder-coated	117.9 97.0 51.2 588229500 588130500 588132500
Framax hose to panel coupler SCC Framax-Spindelaufsatz SCC Galvanised Length: 48 cm Diameter: 27 cm	10.0	588121000			
Panel closure tool D125 SCC Sperrschieber D125 SCC Galvanised Length: 18 cm Width: 33 cm Height: 27 cm	18.0	588127000			

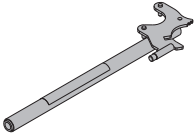
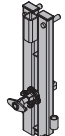
	[kg]	Article N°
Framax Xlife plus outs. corner 10/10cm 3.30m	87.4	589310000
Framax Xlife plus outs. corner 10/10cm 3.00m	81.5	589361000
Framax Xlife plus outs. corner 10/10cm 2.70m	72.5	589311000
Framax Xlife plus outs. corner 10/10cm 1.35m	39.5	589312000
Framax Xlife plus outs. corner 10/10cm 0.60m	19.8	589320000
Framax Xlife plus-Außenecke 10/10cm Galvanised, powder-coated		
		
Framax outside corner 3.30m	58.0	588227000
Framax outside corner 3.00m	52.2	588964500
Framax outside corner 2.70m	47.0	588126000
Framax outside corner 1.35m	23.5	588128000
Framax outside corner 0.60m	11.1	589319000
Framax-Außenecke Galvanised		
		
Framax hinged inside corner I galv. 2.70m	105.8	588136500
Framax hinged inside corner I galv. 1.35m	57.2	588137500
Framax hinged inside corner I galv. 3.30m	129.2	588610500
Framax-Scharnierecke I Galvanised, powder-coated		
		
Framax hinged inside corner I 2.70m	102.3	588136000
Framax hinged inside corner I 1.35m	55.4	588137000
Framax hinged inside corner I 3.30m	125.5	588610000
Framax-Scharnierecke I Powder-coated blue		
		
Framax hinged outside corner A galv. 3.30m	64.0	588975000
Framax hinged outside corner A galv. 2.70m	52.8	588942000
Framax hinged outside corner A galv. 1.35m	27.5	588943000
Framax-Scharnierecke A verzinkt Galvanised, powder-coated		
		

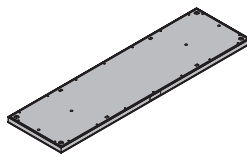
	[kg]	Article N°
Framax hinged outside corner A 2.70m	52.8	588134000
Framax hinged outside corner A 1.35m	27.4	588135000
Framax-Scharnierecke A Powder-coated blue		
		
Framax Xlife pilaster panel 1.35m left	97.7	588973000
Framax Xlife pilaster panel 1.35m right	97.7	588974000
Framax Xlife pilaster panel 3.30m left	234.5	588971000
Framax Xlife pilaster panel 3.30m right	233.5	588972000
Framax Xlife-Stützenvorlageelement Galvanised		
		
Framax stripping corner I 2.70m	171.0	588675000
Framax stripping corner I 1.35m	90.0	588614000
Framax stripping corner I 3.30m	209.9	588676000
Framax-Ausschalecke I Galvanised, powder-coated		
		
Framax stripping spindle I	3.2	588618000
Framax-Ausschalsspindel I Galvanised Height: 25 cm		
		
Framax stripping spindle I with ratchet	5.5	588653000
Framax-Ausschalsspindel I mit Ratsche Galvanised Height: 24.8 cm		
		
Framax stripping cylinder I NG2	30.0	588980500
Framax-Ausschalzylinder I NG2 Painted yellow Width: 16 cm Height: 45.2 cm Follow the directions in the "Operating Instructions"!		
		
		CE

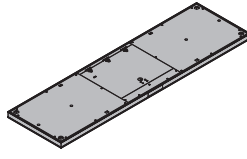
	[kg]	Article N°		[kg]	Article N°	
Framax stripping cylinder I Framax-Ausschalzylinder I  Painted yellow Width: 16 cm Height: 45.2 cm Follow the directions in the "Operating Instructions"!	29.0	588980000	CE	Star grip nut 15.0 G Sternmutter 15,0 G  Galvanised Width: 10 cm Height: 5 cm Width-across: 27 mm	0.43	587544000
Framax quick acting clamp RU Framax-Schnellspanner RU  Galvanised Length: 20 cm	3.1	588153400		Framax stop-end tie Framax-Stirnanker  Galvanised Length: 29 cm	1.5	588143000
Framax multi function clamp Framax-Uni-Spanner  Galvanised Length: 40 cm	5.8	588169000	Rod connector 15.0 Verbindungsmuffe 15,0  Non-treated Length: 10.5 cm Diameter: 3.2 cm	0.49	581981000	
Framax adjustable clamp Framax-Ausgleichsspanner  Galvanised Length: 48 cm	5.3	588168000	Framax universal waling 0.60m Framax universal waling 0.90m Framax universal waling 1.50m Framax-Klemmschiene  Painted blue	6.6 10.6 16.8	588689000 588150000 588148000	
Framax aligning clamp Framax-Richtspanner  Galvanised	8.0	589244000	Framax universal corner waling Framax-Eckklemmschiene  Painted blue Length: 60 cm Width: 60 cm	12.8	588151000	
Framax stop-end waler tie 15-45cm Framax stop-end waler tie 15-75cm Framax-Stirnabschalzwinge  Galvanised	15.0 20.6	588940000 588941000	Framax wedge clamp Framax-Spannklemme  Galvanised Length: 21 cm	1.5	588152000	
Framax universal fixing bolt 10-16cm Framax-Universalverbinder 10-16cm  Galvanised Length: 26 cm	0.6	588158000	Universal clamp 5-10cm Universalklemme 5-10cm  Galvanised Length: 28 cm	1.9	589184000	
Framax universal fixing bolt 10-25cm Framax-Universalverbinder 10-25cm  Galvanised Length: 36 cm	0.69	583002000	Framax tensioning wedge R Framax-Spannkeil R  Galvanised Height: 11 cm	0.2	588155000	
			Framax wedge bolt RA 7.5 Framax-Keilbolzen RA 7,5  Galvanised Length: 15 cm	0.34	588159000	
			Framax head anchor 15-40cm Length: 72 - 81 cm Framax head anchor 15-100cm Length: 131 - 141 cm Framax-Kopfanker  Galvanised, powder-coated	4.2 6.1	588969000 588970000	

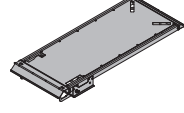
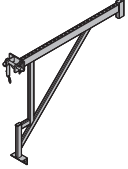
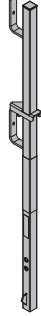
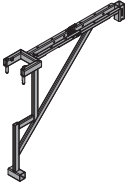
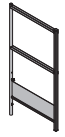
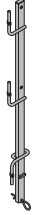
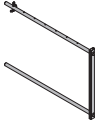
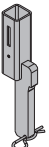
	[kg]	Article N°		[kg]	Article N°
Framax floor fixing plate Framax-Bodenhalter  Galvanised Length: 17.6 cm Width: 7.7 cm	0.87	588628000			
Wall-formwork support angle Auflagewinkel Wandschalung  Galvanised Length: 15.8 cm Width: 12 cm Height: 28 cm	6.6	588967000			
Wall-formwork support angle 2G Auflagewinkel Wandschalung 2G  Galvanised	7.0	589251000			
Panel strut 340 IB Elementstütze 340 IB consisting of: (A) Plumbing strut 340 IB Galvanised Length: 190.8 - 341.8 cm (B) Adjusting strut 120 IB Galvanised Length: 81.5 - 130.6 cm Galvanised Delivery condition: folded closed 	24.3	580365000			
Panel strut 540 IB Elementstütze 540 IB consisting of: (A) Plumbing strut 540 IB Galvanised Length: 310.5 - 549.2 cm (B) Adjusting strut 220 IB Galvanised Length: 172.5 - 221.1 cm Galvanised Delivery condition: folded closed 	41.4	580366000			
Eurex 60 550 Eurex 60 550 depending on length, comprising: (A) Plumbing strut Eurex 60 550 Powder-coated blue Aluminium Length: 343 - 553 cm (B) Extension Eurex 60 2.00m Powder-coated blue Aluminium Length: 250 cm (C) Coupler Eurex 60 Aluminium Length: 100 cm Diameter: 12.8 cm (D) Connector Eurex 60 IB Galvanised Length: 15 cm Width: 15 cm Height: 30 cm (E) Plumbing strut shoe Eurex 60 EB Galvanised Length: 31 cm Width: 12 cm Height: 33 cm (F) Adjusting strut 540 Eurex 60 IB Galvanised Length: 303.5 - 542.2 cm Delivery condition: separate parts 	42.5	582658000			
Prop head EB Stützenkopf EB  Galvanised Length: 40.8 cm Width: 11.8 cm Height: 17.6 cm	3.1	588244500			
Framax panel strut connector I Framax-Elementstützenanschluss I  Galvanised	29.0	589250000			

	[kg]	Article N°		[kg]	Article N°	
Universal dismantling tool Universal-Lösewerkzeug  Galvanised Length: 75.5 cm	3.6	582768000		Framax adapter XBS Framax-Adapter XBS 	5.2	588701000
Doka express anchor 16x125mm Doka-Expressanker 16x125mm  Galvanised Length: 18 cm	0.31	588631000		Deck XBS 75/270cm Deck XBS 75/135cm Belag XBS  Aluminium	23.0	588702000
Doka coil 16mm Doka-Coil 16mm  Galvanised Diameter: 1.6 cm	0.009	588633000		Hatch deck XBS 75/270cm Durchstiegsbelag XBS 75/270cm  Aluminium	24.9	588703000
Information plate for express anchor Plakette Expressanker  PS Width: 8 cm Height: 7.5 cm	0.1	588630000		Infill deck XBS 75cm Ausgleichsbelag XBS 75cm  Aluminium	25.0	588704000
Framax bracket 90 EP Framax-Konsole 90 EP  Galvanised Length: 103 cm Height: 84 cm	9.0	588979000		Handrail post XBS 1.40m Geländersteher XBS 1,40m 	4.0	588705000
Bracket XBS 90 EP Konsole XBS 90 EP 	10.2	588700000		Side railing XBS 75cm Seitengeländer XBS 75cm 	10.0	588706000
Handrail post 1.00m Geländer 1,00m  Galvanised Length: 124 cm	3.8	584335000		Handrail extension XBS Geländerverlängerung XBS 	6.3	588707000
Bracket adapter XP FRR 50/30 Konsolenadapter XP FRR 50/30  Galvanised Height: 32 cm	2.4	586486000		Scaffold tube connection Gerüstrohranschluss  Galvanised Height: 7 cm	0.27	584375000

	[kg]	Article N°
Scaffold tube 48.3mm 0.50m	1.7	682026000
Scaffold tube 48.3mm 1.00m	3.6	682014000
Scaffold tube 48.3mm 1.50m	5.4	682015000
Scaffold tube 48.3mm 2.00m	7.2	682016000
Scaffold tube 48.3mm 2.50m	8.4	682017000
Scaffold tube 48.3mm 3.00m	10.8	682018000
Scaffold tube 48.3mm 3.50m	12.6	682019000
Scaffold tube 48.3mm 4.00m	14.4	682021000
Scaffold tube 48.3mm 4.50m	16.2	682022000
Scaffold tube 48.3mm 5.00m	18.0	682023000
Scaffold tube 48.3mm 5.50m	19.8	682024000
Scaffold tube 48.3mm 6.00m	21.6	682025000
Scaffold tube 48.3mmm	3.6	682001000

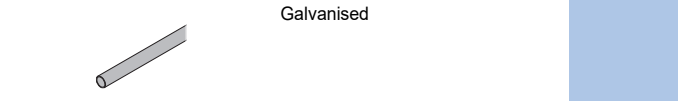

Screw-on coupler 48mm 50 Anschraubkupplung 48mm 50	0.8	682002000
--	-----	-----------



Framax pouring platform U 1.25/2.70m Framax-Betonierbühne U 1,25/2,70m	127.5	588377000
--	-------	-----------



Xsafe plus lifting adapter Framax Xsafe plus-Umsetzadapter Framax	6.6	586436000
---	-----	-----------



Xsafe plus platform 2.70m with side railing Xsafe plus-Bühne 2,70m mit Seitengeländer	189.0	586401000
---	-------	-----------



Xsafe plus platform 1.35m with side railing Xsafe plus-Bühne 1,35m mit Seitengeländer	131.5	586438000
---	-------	-----------

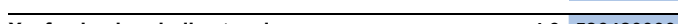

Xsafe plus handrail extension Xsafe plus-Geländerverlängerung	4.3	586420000
---	-----	-----------



	[kg]	Article N°
Xsafe plus counter railing 1.35m	17.0	586429000
Xsafe plus counter railing 2.70m	23.5	586425000



Xsafe plus supporting strut EB Xsafe plus-Stützenstrebe EB	8.0	586412500
--	-----	-----------



Xsafe plus telescopic ladder Xsafe plus-Teleskopleiter	17.1	586421000
--	------	-----------

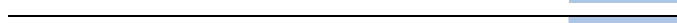

Xsafe plus ladder extension 1.15m Xsafe plus-Leiternverlängerung 1,15m	7.0	586422000
--	-----	-----------



Xsafe plus ladder starter piece Xsafe plus-Leiternhalter	6.8	586424000
--	-----	-----------

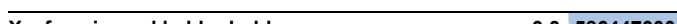



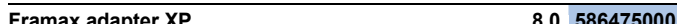





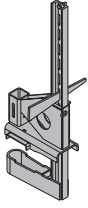
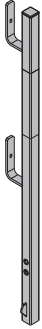

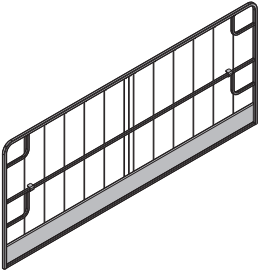
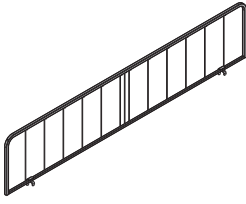
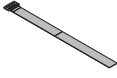

Xsafe universal ladder holder Xsafe-Uni-Leiternhalter	3.3	586447000
---	-----	-----------

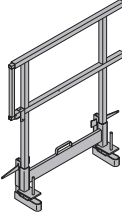
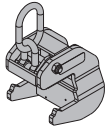
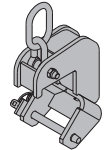

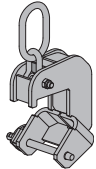







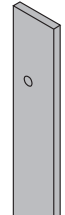
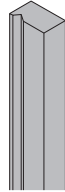



Framax adapter XP Framax-Adapter XP	8.0	586475000
---	-----	-----------

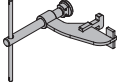



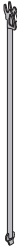

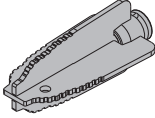
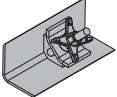
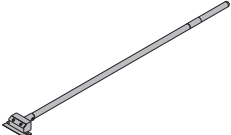
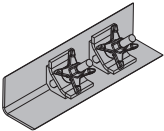
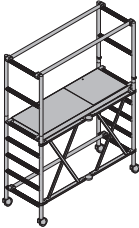
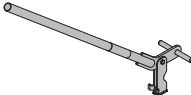
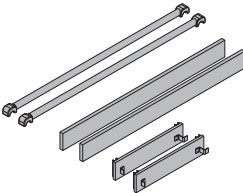



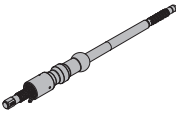

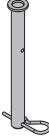
	[kg]	Article N°		[kg]	Article N°
Railing clamp XP 40cm Geländerzwinge XP 40cm  Galvanised Height: 73 cm	7.7	586456000			
Handrail post XP 1.20m Geländersteher XP 1,20m  Galvanised Height: 118 cm	4.1	586460000			
Toeboard holder XP 1.20m Fußwehhalter XP 1,20m  Galvanised Height: 21 cm	0.64	586461000			
Handrail post XP 0.60m Geländersteher XP 0,60m  Galvanised Height: 68 cm	5.0	586462000			
Toeboard holder XP 0.60m Fußwehhalter XP 0,60m  Galvanised Height: 21 cm	0.77	586463000			
Protective grating XP 2.70x1.20m Protective grating XP 2.50x1.20m Protective grating XP 2.00x1.20m Protective grating XP 1.20x1.20m Schutzgitter XP  Galvanised	22.2 20.5 17.4 12.0	586450000 586451000 586452000 586453000			
Protective grating XP 2.70x0.60m Protective grating XP 2.50x0.60m Protective grating XP 2.00x0.60m Protective grating XP 1.20x0.60m Schutzgitter XP  Galvanised	10.1 9.5 8.0 5.0	586466000 586472000 586473000 586491000			
Velcro fastener 30x380mm Klettverschluss 30x380mm  Yellow	0.02	586470000			
Handrail clamp S Schutzgeländerzwinge S  Galvanised Height: 123 - 171 cm	11.5	580470000			
Handrail post 1.10m Schutzgeländer 1,10m  Galvanised Height: 134 cm	5.5	584384000			
Side handrail clamping unit T Seitenschutzgeländer T  Galvanised Length: 115 - 175 cm Height: 112 cm	29.1	580488000			
Framax lifting hook Framax-Umsetzbügel  Galvanised Height: 22 cm Follow the directions in the "Operating Instructions"!	10.6	588149000			CE
Framax lifting hook 20kN Framax-Umsetzbügel 20kN  Galvanised Height: 30 cm Follow the directions in the "Operating Instructions"!	12.8	588526000			CE

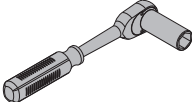

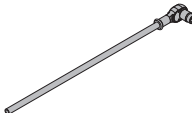
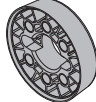



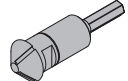

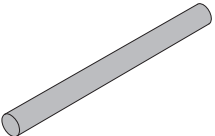
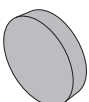

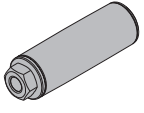
	[kg]	Article N°
Framax lifting hook 25kN Framax-Umsetzbügel 25kN  Galvanised Height: 30 cm Follow the directions in the "Operating Instructions"!	12.5	588531000
		CE
Framax Xlife plus stacking cone Framax Xlife plus-Stapelkonus  Blue Diameter: 8 cm	0.03	589285000
Framax Xlife plus stacking cone I Framax Xlife plus-Stapelkonus I  Black Diameter: 8 cm	0.03	589286000
Doka 4-part chain 3.20m Doka-Vierstrangkette 3,20m  Follow the directions in the "Operating Instructions"!	15.0	588620000
		CE
Framax transport bolt Framax-Transportbolzen  Follow the directions in the "Operating Instructions"!	1.9	588621000
		CE
Framax transport gear Framax-Transportgehänge  Galvanised Follow the directions in the "Operating Instructions"!	13.3	588232000
		CE
Dokamatic lifting strap 13.00m Dokamatic-Umsatzgurt 13,00m  Green Follow the directions in the "Operating Instructions"!	10.5	586231000
		CE

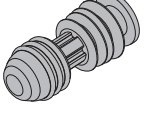
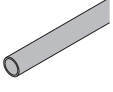
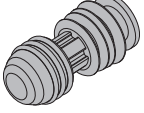

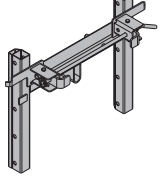

	[kg]	Article N°
Framax fitting timber 2x12cm 2.70m Framax fitting timber 3x12cm 2.70m Framax fitting timber 5x12cm 2.70m Framax fitting timber 10x12cm 2.70m Framax fitting timber 2x12cm 3.30m Framax fitting timber 3x12cm 3.30m Framax fitting timber 5x12cm 3.30m Framax fitting timber 10x12cm 3.30m Framax-Passholz Varnished yellow 	3.1 4.7 7.8 15.5 3.8 5.7 9.5 19.0	176020000 176022000 176024000 176026000 176021000 176023000 176025000 176027000
Framax moulded timber 27mm 2.70m Framax moulded timber 21mm 2.70m Framax moulded timber 18mm 2.70m Framax moulded timber 27mm 3.30m Framax moulded timber 21mm 3.30m Framax moulded timber 18mm 3.30m Framax-Profilholz Varnished yellow 	7.6 8.0 8.4 9.3 9.8 10.2	176012000 176010000 176119000 176013000 176011000 176120000
Framax formwork stripping timb. 10x12cm 2.85m Framax formwork stripping timb. 10x12cm 3.45m Framax-Ausschalholz Varnished yellow 	16.4 19.9	176008000 176014000
Framax aluminium closure 10cm 3.30m Framax aluminium closure 10cm 2.70m Framax aluminium closure 10cm 1.35m Framax aluminium closure 10cm 0.60m Framax aluminium closure 5cm 3.30m Framax aluminium closure 5cm 2.70m Framax aluminium closure 5cm 1.35m Framax aluminium closure 5cm 0.60m Powder-coated 	12.9 11.0 5.7 2.6 10.5 8.5 4.4 1.9	589229000 589227000 589225000 589243000 589228000 589226000 589224000 589242000

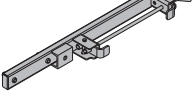
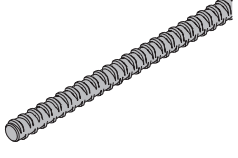
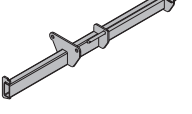
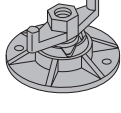
	[kg]	Article N°		[kg]	Article N°
Framax Xlife plus alumin. closure 10cm 3.00m Framax Xlife plus alumin. closure 5cm 3.00m	11.9 9.5	589366000 589367000	 Powder-coated grey	Framax stripping aid Framax-Ausschalhilfe	3.2 589246000
				 Galvanised	
				Framax telescopic assembling tool Framax-Teleskop-Montagegange	3.8 588651000
				 Aluminium Length: 230 - 400 cm	
Connecting timber Anklemmholz	0.7	176030000	 Varnished yellow Width: 10 cm		
Framax triangular ledge 2.70m Framax-Dreikantleiste 2,70m	0.38	588170000		Framax assembling tool Framax-Montagegange	4.2 588678000
				 Galvanised Length: 193 cm	
Framax frontal triangular ledge 2.70m Framax frontal triangular ledge 3.30m	1.7 2.0	588129000 588949000	 Grey		
Framax plug R24.5 Framax-Abdeckstopfen R24,5	0.003	588181000	 Yellow Diameter: 2 cm	Framax Xlife plus anchoring-sleeve cleaner Framax Xlife plus-Ankerhülsenreiniger	0.85 589328000
				 Painted blue Length: 16.6 cm	
Box-out clamp type 1cm Aussparungsklemme Typ 1cm	17.4	580066000	 Painted blue Length: 10 cm Width: 10 cm	Double scraper Xlife 100/150mm 1.40m Doppelschaber Xlife 100/150mm 1,40m	2.8 588674000
					
Box-out clamp type 2cm Aussparungsklemme Typ 2cm	17.4	580067000	 Painted blue Length: 10 cm Width: 10 cm	Wheel-around scaffold DF Mobilgerüst DF	44.0 586157000
				 Aluminium Length: 185 cm Width: 80 cm Height: 255 cm Delivery condition: separate parts	
Framax positioning lever Framax-Einrichthebel	5.6	589245000	 Galvanised Length: 135 cm	Wheel-around scaffold DF accessory set Zubehörset Mobilgerüst DF	13.3 586164000
				 Aluminium Timber parts varnished yellow Length: 189 cm	
Framax stripping tool Framax-Ausschalwerkzeug	5.5	589235000	 Galvanised Length: 110 cm		

	[kg]	Article N°
Tie-off set PPE type A Anhängeset PSA Typ A	0.49	589199500
		
Tie rod system Framax Xlife plus 20.0		
Framax Xlife plus form tie 20.0 15-30cm Length: 70 cm	5.0	589277000
Framax Xlife plus form tie 20.0 25-40cm Length: 80 cm	5.4	589278000
Framax Xlife plus form tie 20.0 45-60cm Length: 100 cm Framax Xlife plus-Anker 20,0	6.2	589298000
 Galvanised		
Framax Xlife plus tie rod 20.0 15-30cm Length: 70 cm	2.7	589324000
Framax Xlife plus tie rod 20.0 25-40cm Length: 80 cm	3.1	589325000
Framax Xlife plus tie rod 20.0 45-60cm Length: 100 cm Framax Xlife plus-Ankerstab 20,0	4.0	589326000
 Galvanised		
Framax Xlife plus form-tie nut I 20.0 Framax Xlife plus-Ankermutter I 20,0	1.2	589216500
 Length: 12 cm		
Framax Xlife plus parking bolt Framax Xlife plus-Parkbolzen	0.42	589327000
 Galvanised Length: 20 cm		
Framax Xlife plus distance protector NG Framax Xlife plus-Distanzsicherung NG	1.3	589217500
 Galvanised Height: 22 cm Width-across: 24 mm		
Framax Xlife plus reducer I 20.0 Framax Xlife plus-Reduzierstück I 20,0	0.56	589329000
 Galvanised Length: 12.5 cm		
Framax Xlife plus ratchet 1/2" SW24 L Framax Xlife plus-Knarre 1/2" SW24 L	0.92	589221000
 Length: 30 cm		

	[kg]	Article N°
Framax Xlife plus ratchet 3/4" SW24 Framax Xlife plus-Knarre 3/4" SW24	4.4	589220000
 Length: 100 cm		
Framax Xlife plus fair-faced concr. cone 87mm Framax Xlife plus-Sichtbetonkonus 87mm	0.09	589282000
 Blue		
Sealing disc 20/43 20.0/26.5 Dichtscheibe 20/43 20,0/26,5	0.002	581836000
 Black		
Screw sleeve 20.0 Schraubhülse 20,0	0.03	584386000
 PP Yellow Length: 20 cm Diameter: 3.1 cm		
Framax Xlife plus cone spanner Framax Xlife plus-Konusschlüssel	0.28	589284000
 Galvanised Length: 5.5 cm		
Countersink concrete D12-35mm Kegelsenker Beton D12-35mm	0.41	589247000
		
Framax Xlife plus plug 38mm Framax Xlife plus-Verschlussstopfen 38mm	0.006	589288000
 PE Grey		
Framax Xlife plus plug 24mm Framax Xlife plus-Verschlussstopfen 24mm	0.005	589219000
 PE Grey		
Framax Xlife plus concrete cone 28/25 300mm Framax Xlife plus-Betonkonus 28/25 300mm	0.36	589338000
 Grey		
Framax Xlife plus fair-faced concr. plug 87mm Framax Xlife plus-Sichtbetonstopfen 87mm	0.19	589283000
 Grey		

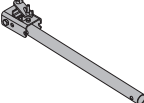
	[kg]	Article N°		[kg]	Article N°
Framax Xlife plus screw plug 25mm Framax Xlife plus-Schraubstopfen 25mm Black Width-across: 16 mm 	0.1	589308000	Hexagon nut 20.0 Sechskantmutter 20,0 Galvanised Length: 7 cm Width-across: 41 mm 	0.4	581420000
Framax Xlife plus sealing plug 25mm Framax Xlife plus-Dichtstopfen 25mm Yellow 	0.02	589248000	Plastic tube 26mm 2.00m Kunststoffrohr 26mm 2,00m PVC Grey Diameter: 3.1 cm 	0.59	581463000
Framax Xlife plus sealing plug 28mm Framax Xlife plus-Dichtstopfen 28mm Blue 	0.02	589249000	Universal cone 26/10mm Universal-Konus 26/10mm Grey Diameter: 5 cm 	0.008	581464000
Fibre concrete plug D24 21mm Faserbetonstopfen D24 21mm Grey 	0.02	588922000	Plug 26mm Verschlussstopfen 26mm PE Grey 	0.006	581465000
Framax Xlife plus plug 24mm with hole Framax Xlife plus-Stopfen 24mm mit Loch PE Colourless 	0.004	589223000	Ladder system XS		
Expanding mortar EM 0-0.4 E1 25kg Expansiv-Mörtel EM 0-0,4 E1 25kg	25.0	699136109	Connector XS wall formwork Anschluss XS Wandschalung Galvanised Width: 89 cm Height: 63 cm 	20.8	588662000
KarPox Double cartridge 2K Duo 2x310ml KarPox Doppelkartusche 2K Duo 2x310ml	0.9	699136090	Fixing clamp XS Framax Befestigungsklemme XS Framax Galvanised Length: 20 cm Width-across: 27 mm 	1.5	588677000
Tie rod system 20.0			Connector XS Framax/Alu-Framax Anschluss XS Framax/Alu-Framax Galvanised Length: 115 cm 	11.2	588639000
Tie rod 20.0mm galvanised 0.50m Tie rod 20.0mm galvanised 0.75m Tie rod 20.0mm galvanised 1.00m Tie rod 20.0mm galvanised 1.25m Tie rod 20.0mm galvanised 1.50m Tie rod 20.0mm galvanised 2.00m Tie rod 20.0mm galvanised 2.50m Tie rod 20.0mm galvanisedm Tie rod 20.0mm non-treated 0.50m Tie rod 20.0mm non-treated 0.75m Tie rod 20.0mm non-treated 1.00m Tie rod 20.0mm non-treated 1.50m Tie rod 20.0mm non-treated 2.00m Tie rod 20.0mm non-treatedm Ankerstab 20,0mm 	1.3 1.9 2.5 3.2 3.8 5.0 6.3 2.5 1.3 1.9 2.5 3.8 5.0 2.5	581411000 581417000 581412000 581418000 581413000 581414000 581430000 581410000 581405000 581416000 581406000 581407000 581408000 581403000	Connector XS column formwork platform Anschluss XS Stützenbühne Galvanised Length: 123 cm 	10.0	588637000
Super plate 20.0 B Superplatte 20,0 B Galvanised Height: 7 cm Diameter: 14 cm Width-across: 34 mm 	2.0	581424000			
					

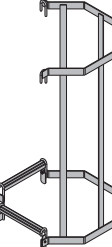
	[kg]	Article N°
System ladder XS 4.40m System-Leiter XS 4,40m  Galvanised	33.2	588640000
Ladder extension XS 2.30m Leiternverlängerung XS 2,30m  Galvanised	19.1	588641000
Securing barrier XS Sicherungsschranke XS  Galvanised Length: 80 cm	4.9	588669000
Ladder cage XS 1.00m Ladder cage XS 0.25m Rückenschutz XS  Galvanised	16.5 10.5	588643000 588670000
Ladder cage exit XS Rückenschutz-Ausstieg XS  Galvanised Height: 132 cm	17.0	588666000

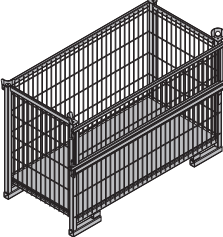
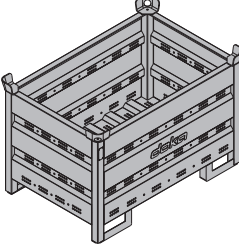
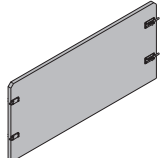
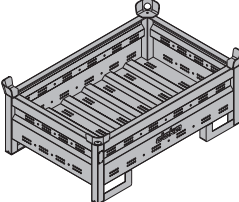
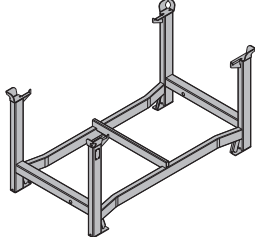
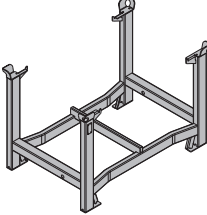
	[kg]	Article N°
Multi-trip packaging Doka skeleton transport box 1.70x0.80m Doka-Gitterbox 1,70x0,80m  Galvanised Height: 113 cm	87.0	583012000
Doka multi-trip transport box 1.20x0.80m Doka-Mehrwegcontainer 1,20x0,80m  Galvanised Height: 78 cm	70.0	583011000
Multi-trip transport box partition 0.80m Multi-trip transport box partition 1.20m Mehrwegcontainer Unterteilung  Steel parts galvanised Timber parts varnished yellow	3.7 5.5	583018000 583017000
Doka multi-trip transport box 1.20x0.80x0.41m Doka-Mehrwegcontainer 1,20x0,80x0,41m  Galvanised	42.5	583009000
Doka stacking pallet 1.55x0.85m Doka-Stapelpalette 1,55x0,85m  Galvanised Height: 77 cm	41.0	586151000
Doka stacking pallet 1.20x0.80m Doka-Stapelpalette 1,20x0,80m  Galvanised Height: 77 cm	38.0	583016000

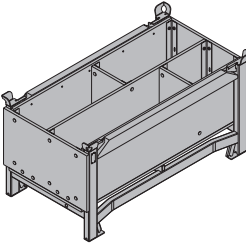
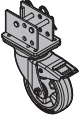
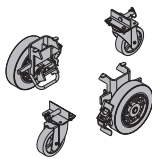
	[kg]	Article N°	[kg]	Article N°
<p>Doka accessory box Doka-Kleinteilebox</p>  <p>Timber parts varnished yellow Steel parts galvanised Length: 154 cm Width: 83 cm Height: 77 cm</p>	106.4	583010000		
<p>Universal castor wheel for transport pallet Universal-Lenkrolle Transportgebinde</p>  <p>Galvanised Height: 28.8 cm</p>	6.0	584043000		
<p>Bolt-on castor set B Anklemm-Radsatz B</p>  <p>Painted blue</p>	33.6	586168000		



Formwork & Scaffolding.
We make it work.



www.doka.com/framax-xlife-plus