

The Formwork Experts.

Composite formwork beams

User Information

Instructions for assembly and use (Method statement)



Contents

4 Introduction

- 4 Elementary safety warnings
- 7 Composite formwork beam I tec 20

8 Product description

9 General

- 10 Deflection diagram
- 12 Technical condition
- 17 Transporting, stacking and storing

18 Article list

Introduction

Elementary safety warnings

User target groups

- This booklet is aimed at all persons who will be working with the Doka product or system that it describes. It contains information on the standard design for setting up this system, and on correct, compliant utilisation of the system.
- All persons working with the product described herein must be familiar with the contents of this booklet and with all the safety instructions it contains.
- Persons who are incapable of reading and understanding this booklet, or who can do so only with difficulty, must be instructed and trained by the customer.
- The customer is to ensure that the information materials provided by Doka (e.g. User Information booklets, Instructions for Assembly and Use, Operating Instruction manuals, plans etc.) are up to date and available to all users, and that they have been made aware of them and have easy access to them at the usage location.
- In the relevant technical documentation and formwork utilisation plans, Doka shows the workplace safety precautions that are necessary in order to use the Doka products safely in the usage situations shown.
In all cases, users are obliged to ensure compliance with national laws, standards and regulations throughout the entire project and to take appropriate additional or alternative workplace safety precautions where necessary.

Hazard assessment

- The customer is responsible for drawing up, documenting, implementing and continually updating a hazard assessment at every job-site. This booklet serves as the basis for the site-specific hazard assessment, and for the instructions given to users on how to prepare and utilise the system. It does not substitute for these, however.

Remarks on this booklet

- This document can be used as general Instructions for Assembly and Use (Method Statement) or be incorporated into site-specific Instructions for Assembly and Use (Method Statement).
- **The graphics, animations and videos in this document or app sometimes depict partially assembled assemblies and may require additional safety equipment and/or measures to comply with safety regulations.**
The customer must ensure all applicable regulations are complied with, even if they are not shown or implied in the graphics, animations and videos provided.
- **Individual sections contain further safety instructions and/or special warnings as applicable.**

Planning

- Provide safe workplaces for those using the formwork (e.g. for when it is being erected/dismantled, modified or repositioned etc). It must be possible to get to and from these workplaces via safe access routes!
- **If you are considering any deviation from the details and instructions given in this booklet, or any application which goes beyond those described in the booklet, then revised static calculations must be produced for checking, as well as supplementary assembly instructions.**

Regulations; industrial safety

- All laws, Standards, industrial safety regulations and other safety rules applying to the utilisation of our products in the country and/or region in which you are operating must be observed at all times.
- If a person or object falls against, or into, the side-guard component and/or any of its accessories, the component affected may only continue in use after it has been inspected and passed by an expert.

Rules applying during all phases of the assignment

- The customer must ensure that this product is erected and dismantled, reset and generally used for its intended purpose in accordance with the applicable laws, standards and rules, under the direction and supervision of suitably skilled persons. These persons' mental and physical capacity must not in any way be impaired by alcohol, medicines or drugs.
- Doka products are technical working appliances which are intended for industrial / commercial use only, always in accordance with the respective Doka User Information booklets or other technical documentation authored by Doka.
- The stability and load-bearing capacity of all components and units must be ensured during all phases of the construction work!
- Do not step on or apply strain to cantilevers, closures, etc. until suitable measures to ensure their stability have been correctly implemented (e.g. by tie-backs).
- Strict attention to and compliance with the functional instructions, safety instructions and load specifications are required. Non-compliance can cause accidents and severe injury (risk of fatality) and considerable damage to property.
- Sources of fire in the vicinity of the formwork are prohibited. Heaters are permissible only when used correctly and situated a correspondingly safe distance from the formwork.
- Customer must give due consideration to any and all effects of the weather on the equipment and regards both its use and storage (e.g. slippery surfaces, risk of slipping, effects of the wind, etc.) and implement appropriate precautionary measures to secure the equipment and surrounding areas and to protect workers.
- All connections must be checked at regular intervals to ensure that they are secure and in full working order.
In particular threaded connections and wedged connections have to be checked and retightened as necessary in accordance with activity on the jobsite and especially after out-of-the-ordinary occurrences (e.g. after a storm).
- It is strictly forbidden to weld Doka products – in particular anchoring/tying components, suspension components, connector components and castings etc. – or otherwise subject them to heating.
Welding causes serious change in the microstructure of the materials from which these components are made. This leads to a dramatic drop in the failure load, representing a very great risk to safety.
It is permissible to cut individual tie rods to length with metal cutting discs (introduction of heat at the end of the rod only), but it is important to ensure that flying sparks do not heat and thus damage other tie rods.
The only articles which are allowed to be welded are those for which the Doka literature expressly points out that welding is permitted.

Assembly

- The equipment/system must be inspected by the customer before use, to ensure that it is in an acceptable condition. Steps must be taken to exclude components that are damaged, deformed, or weakened due to wear, corrosion or rot (e.g. fungal decay).
- Using our safety and formwork systems together with those of other manufacturers can create risks that may lead to injury and damage to property. This requires separate verification by the user.
- The equipment/system must be assembled and erected in accordance with the applicable laws, standards and rules by trained customer personnel whilst maintaining any applicable safety inspections that may be required.
- It is not permitted to modify Doka products; such modifications constitute a safety risk.

Closing the formwork

- Doka products and systems must be set up so that all loads acting upon them are safely transferred!

Pouring

- Do not exceed the permitted fresh-concrete pressures. Over-high pouring rates overload the formwork, cause greater deflection and risk breakage.

Stripping the formwork

- Do not strip out the formwork until the concrete has reached sufficient strength and the person in charge has given the order for the formwork to be stripped out!
- When stripping out the formwork, never use the crane to break concrete cohesion. Use suitable tools such as timber wedges, special pry-bars or system features such as Framax stripping corners.
- When stripping out the formwork, do not endanger the stability of any part of the structure, or of any scaffolding, platforms or formwork that is still in place!

Transporting, stacking and storing

- Observe all country-specific regulations applying to the handling of formwork and scaffolding. For system formwork the Doka slinging means stated in this booklet must be used – this is a mandatory requirement.

If the type of sling is not specified in this document, the customer must use slinging means that are suitable for the application envisaged and that comply with the regulations.

- When lifting, always make sure that the unit to be lifted and its individual parts can absorb the forces that occur.
- Remove loose parts or secure them so that they cannot slip out of position and drop.
- When lifting formwork or formwork accessories with a crane, no persons must be carried along, e.g. on working platforms or in multi-trip packaging.
- All components must be stored safely, following all the special Doka instructions given in the relevant sections of this document!

Maintenance

- Only original Doka components may be used as spare parts. Repairs may only be carried out by the manufacturer or authorised facilities.

Miscellaneous

The weights as stated are averages for new material; actual weights can differ, depending on material tolerances. Dirt accretions, moisture saturation, etc. can also affect weight.

We reserve the right to make alterations in the interests of technical progress.

Symbols used

The following symbols are used in this document:



DANGER

This is a notifier drawing attention to an extremely dangerous situation in which non-compliance with this notifier will lead to death or severe, irreversible injury.



WARNING

This is a notifier drawing attention to a dangerous situation in which non-compliance with this notifier can lead to death or severe, irreversible injury.



CAUTION

This is a notifier drawing attention to a dangerous situation in which non-compliance with this notifier can lead to slight, reversible injury.



NOTICE

This is a notifier drawing attention to a situation in which non-compliance with this notifier can lead to malfunctions or damage to property.



Instruction

Indicates that actions have to be performed by the user.



Sight-check

Indicates that you need to do a sight-check to make sure that necessary actions have been carried out.



Tip

Points out useful practical tips.



Reference

Cross-references other documents.

Composite formwork beam I tec 20

Doka beams I tec 20 are formwork beams made of wood. They are intended for use in load-bearing towers and formwork.

Practical example

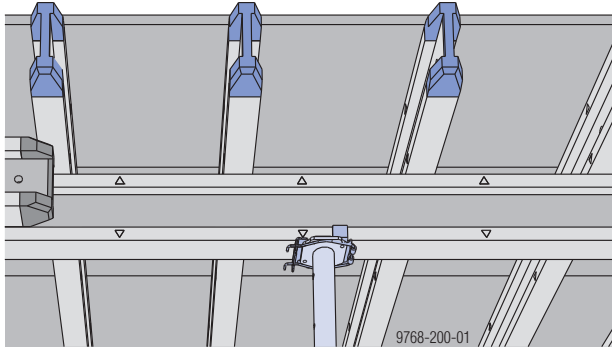

Product description



Dimensions:

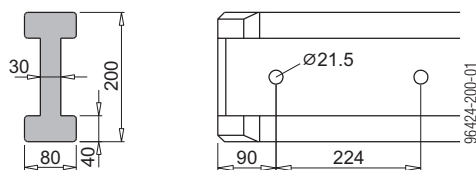

Figures given in mm

Lengths:

Length [m]	
1.80 - 5.90	with end reinforcement
> 5.90 - 12.00	trimmed off straight with ends sealed

For details, see article list.

Tolerances:

	Tolerance
Height	± 1.0 mm
Length up to 6 m	+ 0 / - 3,0 mm
Length > 6 m	± 3.0 mm

Weight: 5,6 kg/lin.m

Mechanical properties

(in accordance with Approval n° Z-9.1-773):

Permitted shear force Q [kN]	20.0
Permitted moment M [kNm]	9.0
Flexural stiffness EI [kNm ²]	640

These values allow for a $\gamma_F = 1.5$, a k_{mod} of 0.9 and a $\gamma_M = 1.3$. Under different conditions of use and/or with moisture content > 20%, the values have to be modified accordingly.

Use

- For use in wall-formwork and slab-formwork systems, tunnel formwork, automatic climbing formwork, etc.
- These beams have the same dimensions as Doka beams H20 but are approximately 80 % stronger, so the reduction in material quantities in slab and wall formwork is considerable.
- Together with the plastic sheet on the broad faces of the flanges, the polyurethane end reinforcement contributes to prolonging service life.
- Beam-flange markings in a 50 cm grid for Dokaflex and Dokaflex 30 tec systems.

The Composite formwork beam I tec 20 is a solid-web beam pursuant to DIBT (German Institute of Building Technology) building-industry approval with a special structure and innovative polyurethane end reinforcement for low material quantities and extended service life.

Basic design concept

- Solid-web beam made of wood and wood-based materials pursuant to national technical approval n° Z-9.1-773.
- Spruce- and birchwood-ply web; plies sorted by visual inspection and 100 % tested by the tensile loading test method (proof-loading). Plastic sheet on the broad faces of the flanges.
- Poplar-plywood web with grey web coating.
- Polyurethane end reinforcement
- 2 system holes at each beam end

Glue-bonding

Glues/adhesives used are tested and approved systems for load-bearing applications indoors and outdoors.

Surfaces

- Yellow varnish without wood preservatives.
- Grey plastic sheet on the broad faces of the flanges.
- Grey web coating.

Technical data

Note:

All values in the tables are based on a wood moisture content of $12 \pm 2\%$ on delivery. Changes in the wood's moisture content can have effects on the weight, dimensions and mechanical properties of the beam.

Doka beams I tec 20 are designed for loading in the direction of the height of the beam.

General

Note:

- To achieve maximum service life, follow the storage instructions (see the section headed 'Transporting, stacking and storing'). Prudent handling is also important, particularly when stripping out slabs.
- If the ends of beams are square-cut at Doka branches or at jobsites, they must be treated with I tec 20 beam-end sealant in order to ensure the full lifespan of the beam.

Possible incorrect usages

WARNING

▶ Use Doka formwork beams only in the 'upright' position.

The only exceptions to this rule are use cases explicitly permitted in Doka documents (e.g. in formwork for casting drop beams with the Beam forming support 20, etc.)

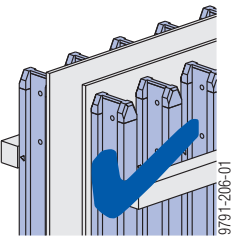
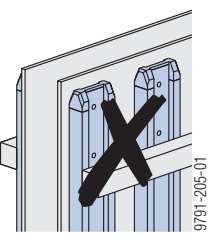
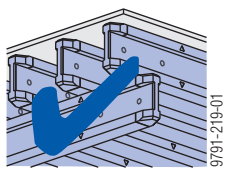
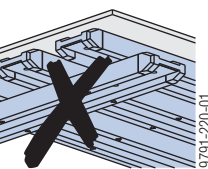
Correct 'upright' use (load direction parallel to web plane).	Incorrect 'turned flat' use (load direction transverse to web plane).
<p>Wall formwork</p>  <p>9791-206-01</p>	 <p>9791-205-01</p>
<p>Slab formwork</p>  <p>9791-219-01</p>	 <p>9791-220-01</p>

WARNING

▶ The uses illustrated below are prohibited, as are other, similar uses!

Do not use as scaffold planking.

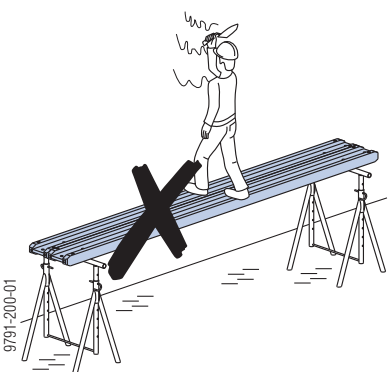

9791-200-01

Do not use for constructing access routes.

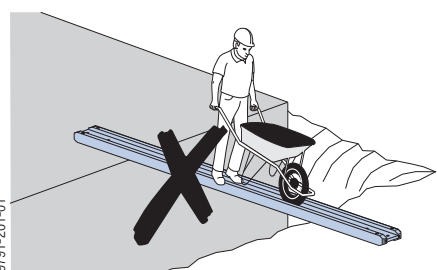

9791-201-01

Reprocessing scrap material

Doka formwork beams contain no wood preservatives and, consequently, they can be deposited for reprocessing.

Reprocessing by incineration in suitable incineration plants is recommended. It is advisable not to attempt to burn scrap material in open fires or domestic wood-burners.

Always comply with the applicable local or national regulations.

Deflection diagram

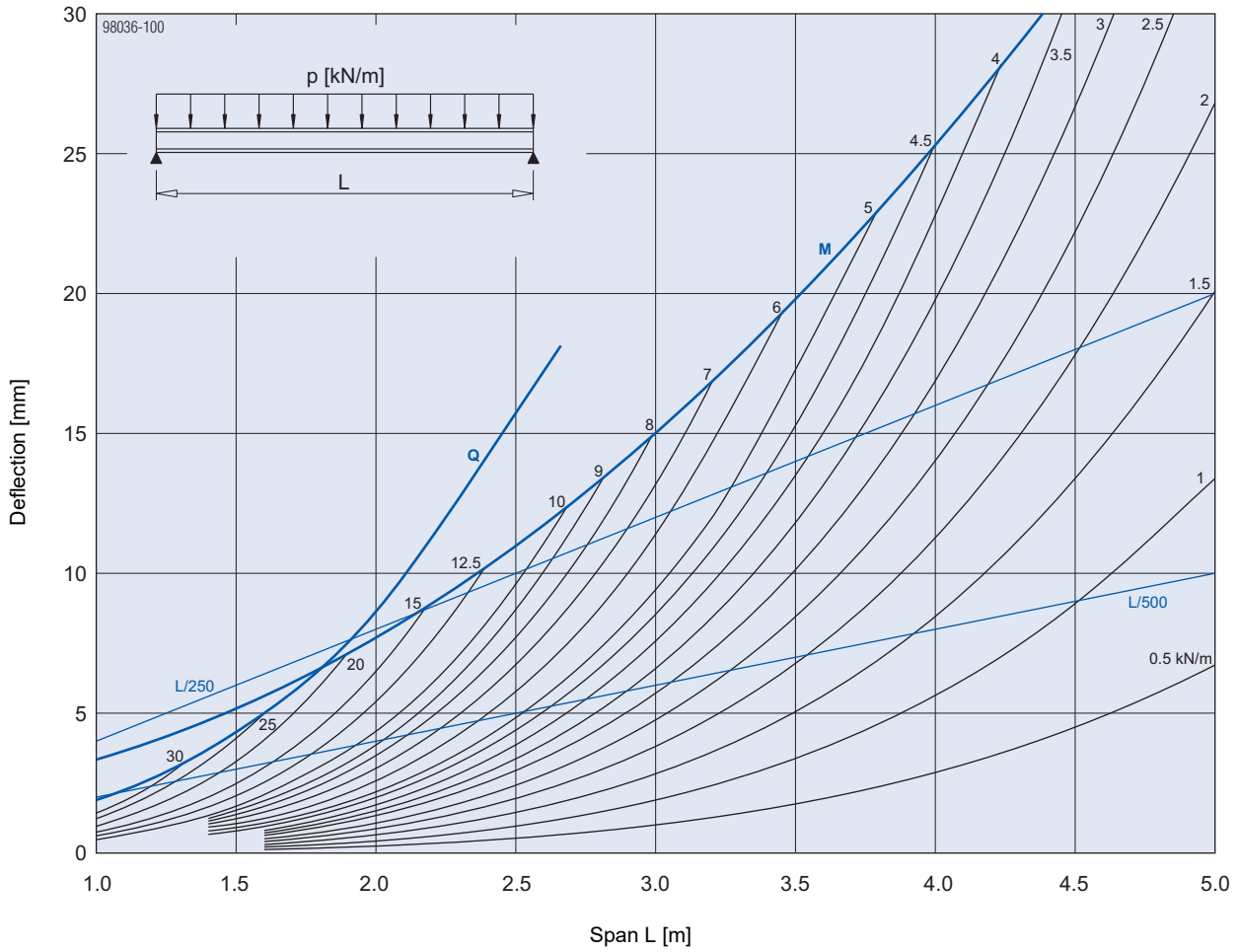

M ... permitted bending moment
 Q ... permitted shear force
 p ... actual load (service load)

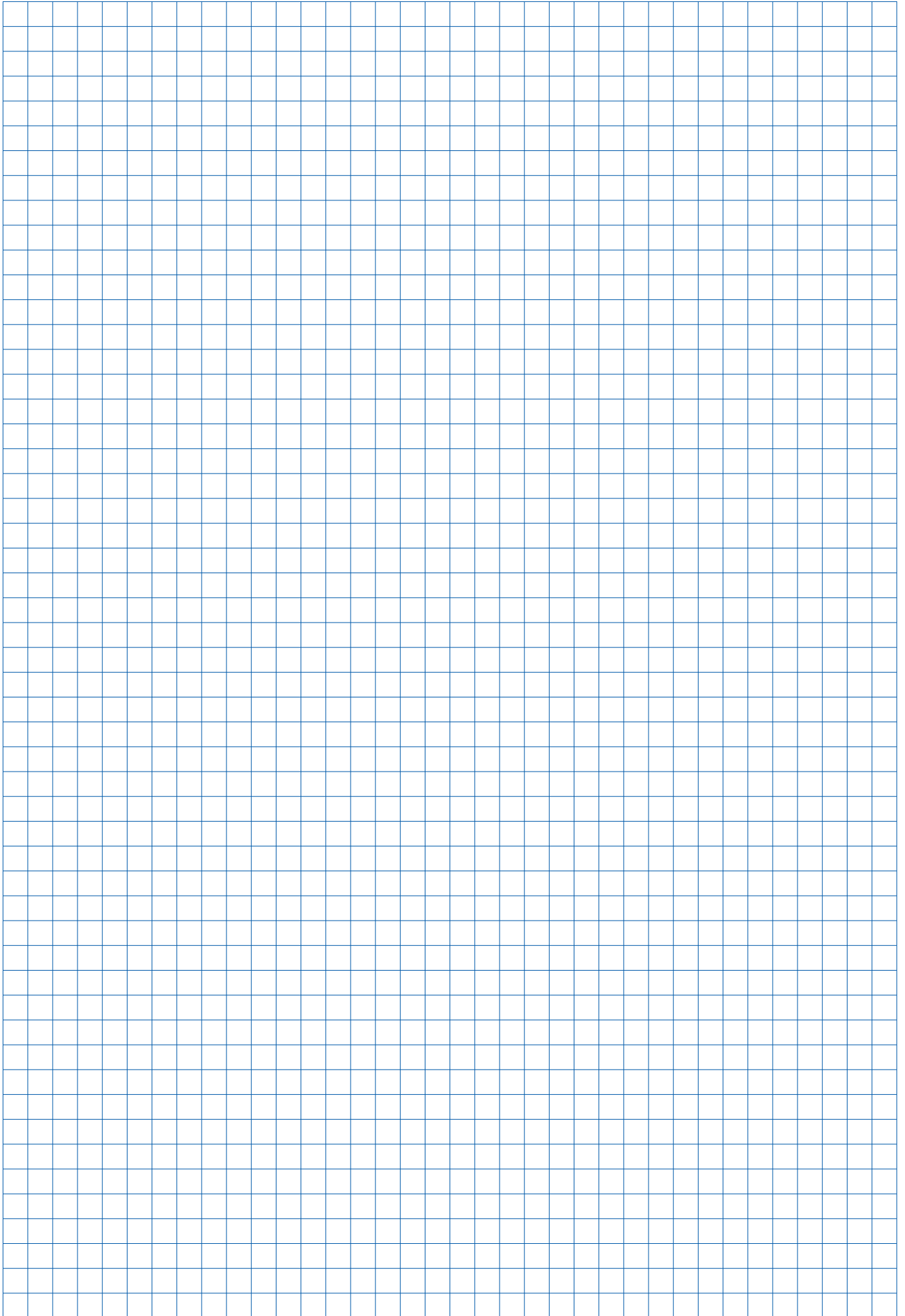

Technical condition

The following quality criteria define the statically permitted degree of damage or weakening.

Use is prohibited if the damage is more extensive.

Flange

Angled cracks (across the grain)

- Not permissible.

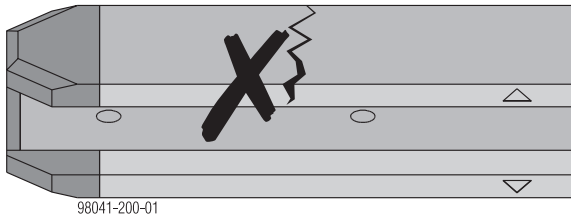

Straight cracks (parallel to the flange)

- parallel to flange, permissible up to width $a = 2 \text{ mm}$.
- If the flange can be parted at the crack the beam is not in usable condition.

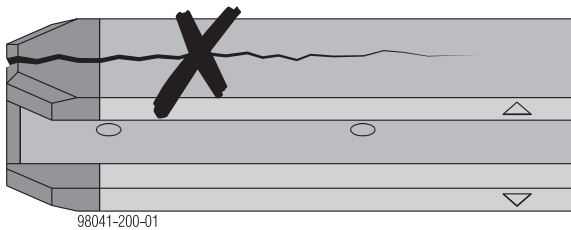
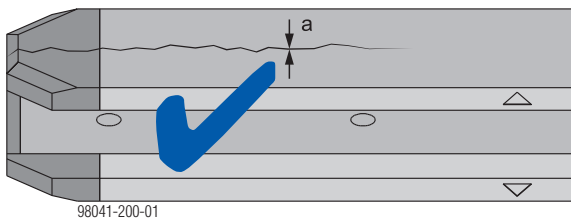

Splintering at side

- permissible up to depth $a = 10 \text{ mm}$ and length $b = 500 \text{ mm}$ on one side.

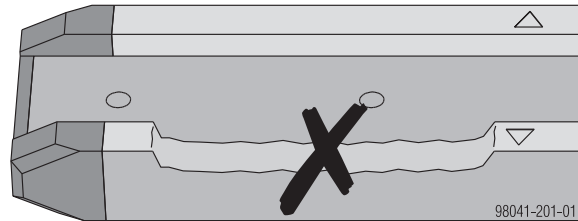
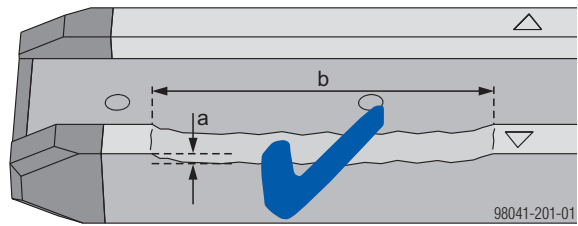

Angled splintering across the edge

- permissible up to $a = 30 \text{ mm}$ across the diagonal and up length $b = 500 \text{ mm}$.

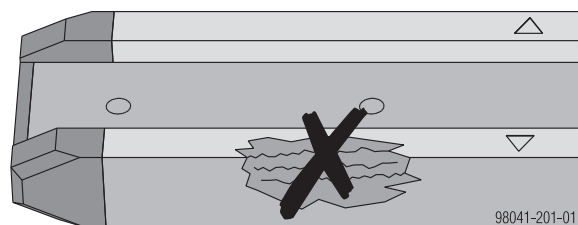
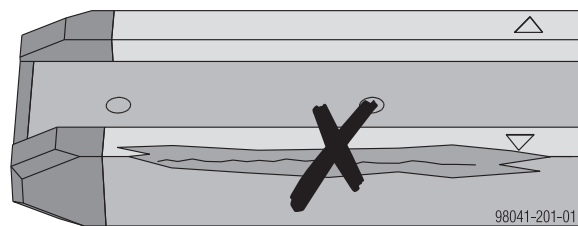
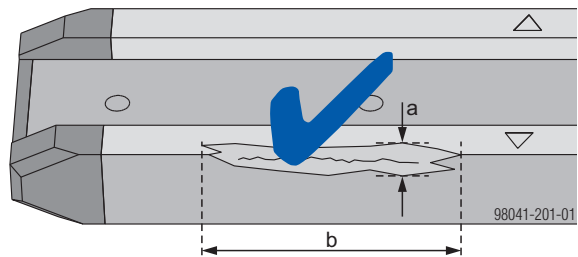

Openings in joints

- permissible up to $a = 1 \text{ mm}$.

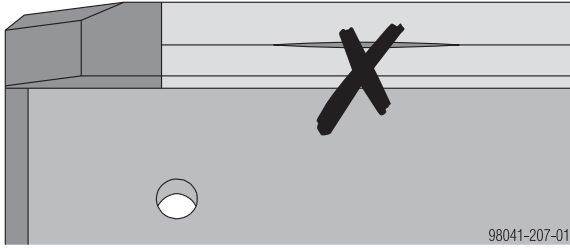
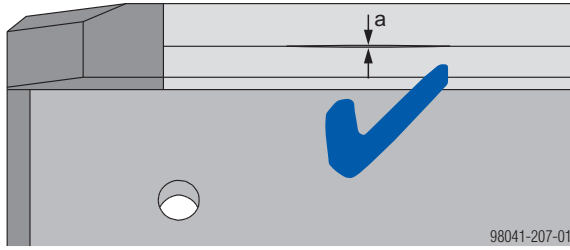

Saw cuts

- Superficial saw cuts up to depth $a = 2 \text{ mm}$ are permissible.

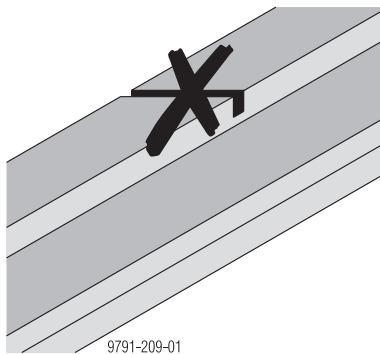
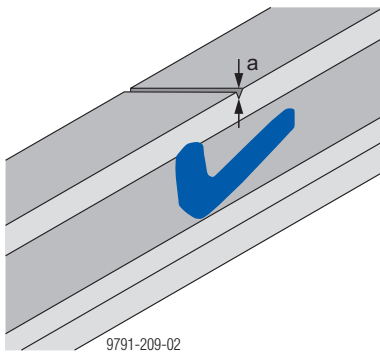

Flange end

- Splintering **a up to length = 60 mm** is permissible.
- Damage to the plastic cap has no effect on load-bearing capacity, but beams evincing damage of this kind do not necessarily meet the quality criteria for Doka rental formwork.

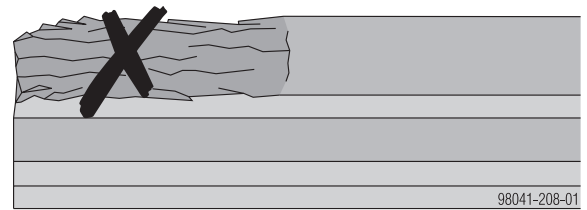
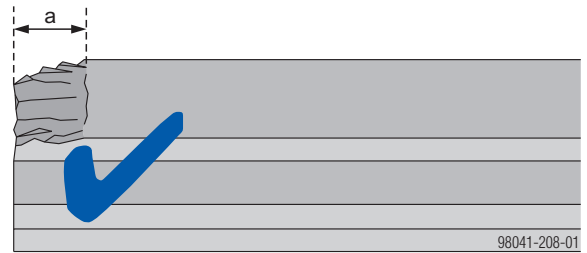

Drilled holes

- Not permissible, with the exception of system holes:

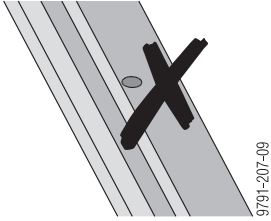

- Waling attachment with beam screw

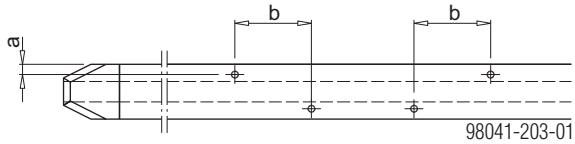

a ... 15 mm

b ... 112 mm

Drilled-hole diameter max. 10 mm

- Attachment of table head with beam screw

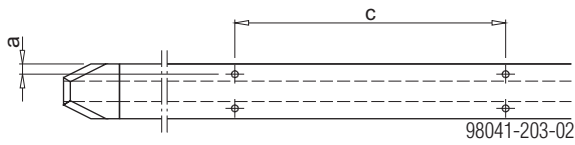

a ... 15 mm

c ... 396 mm

Drilled-hole diameter max. 10 mm

- Attachment of profiled timber formers

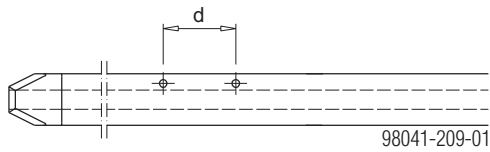

d ... 113 mm

Drilled-hole diameter max. 12 mm

Web

Damage to web

- permissible only if slight and at one side of the beam.

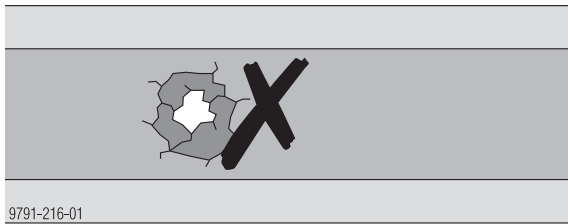
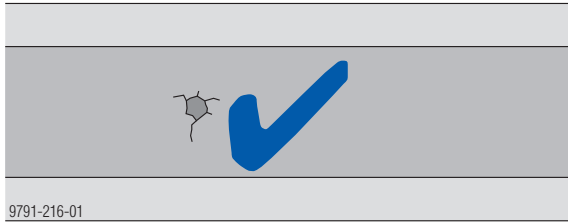

Damage to web end

- permissible up to max. $a = 20$ mm

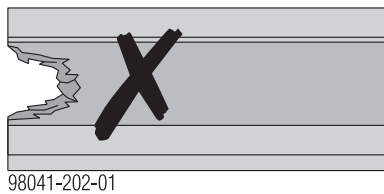
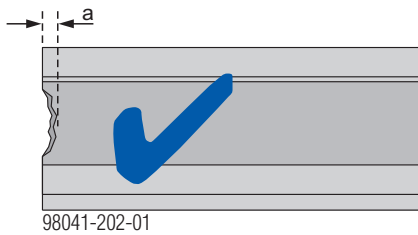

Drilled holes in web

Permissible drilled holes:

- Standard holes
 - Each standard beam has 2 drilled holes, dia. 21.5 mm
- Additional system holes for:
 - Flange claw
 - Fastening plate
 - Connection splice plate
 - Table head 30
 - Lifting bracket
 - Portal head

One drilled hole of maximum diameter 20 mm per running metre in addition to the system holes is permissible.

If the incidence of drilled holes is frequent the overall condition of the beam is definitive.

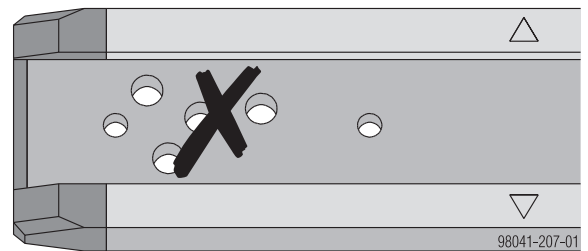
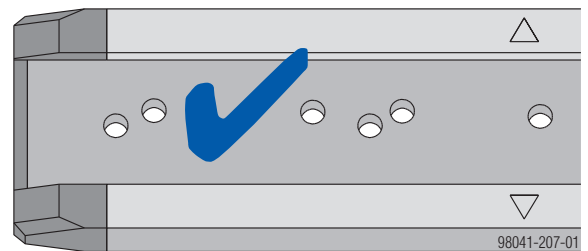

Detachment of flange from web

- Not permissible.

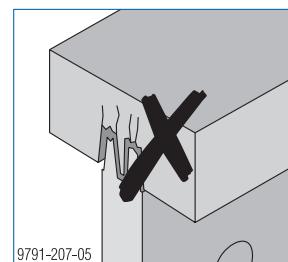

Flange/web

Fungal attack

Mould/blueing

Appearance:

- Black spots
- White filaments
- Blue to black discolouration

Wood discolouration caused by mould/blueing has no effect on the load-bearing capacity of the beam.



WARNING

- ▶ Mould/blueing can occur in combination with wood-degrading fungi (timber-decay fungi, dry rot).

Timber-decay fungi

Timber-decay fungi reduce the beam's load-bearing capacity.



WARNING

- ▶ Scrap beams weakened by timber-decay fungi!

They can be identified by their reduced compressive strength compared to sound sections, for example by compression-testing with a plain, slot-screw screwdriver.

Transporting, stacking and storing

Transport

- Always use slings for lifting beam stacks - do not use chains.

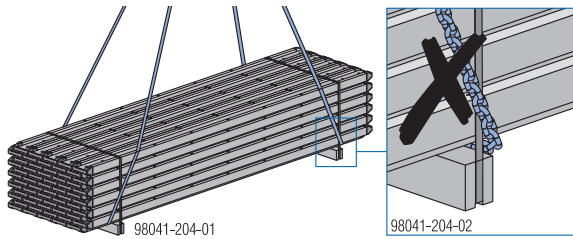

NOTICE

When transporting loose beams without strapping, make sure that the beams cannot slip!

Stacked beams

- max. 3000 kg per stack

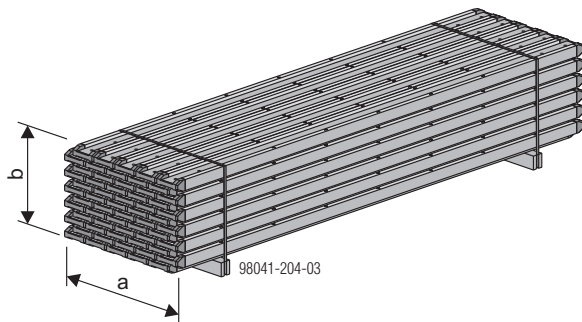

	Lengths of beam	
	Up to 6.50 m	Over 6.50 m
Max. n° of beams per stack	60	40
Minimum n° of timber supports (min. 10 x 8 x 109 cm)	2	3
Dimension 'a'	108 cm	
Dimension 'b'	78 cm	56 cm

- Always use edge protectors when strapping beams together. Edge protectors can be padding made of plastic, wood or cardboard.





Packets of 60 beams	Packets of 40 beams
Max. 2 packets on top of one another	Max. 4 packets on top of one another

Ground conditions for stacking

- Maximum angle of inclination of ground 3%.
- The ground on which the stack is to be placed must be adequately firm and level. Best-case conditions are concreted or paved storage areas.
- Storage on asphalt: Depending on the parts stored, place wooden battens, strips of formwork sheeting or metal sheet between the parts and the asphalt surface to ensure that the weight is adequately spread.
- Storage on other surfaces (sand, gravel...): Adopt suitable measures for storage (e.g. place thick plywood sheets underneath the loads).

Protection from wind and weather

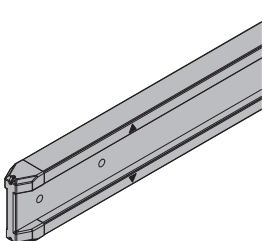
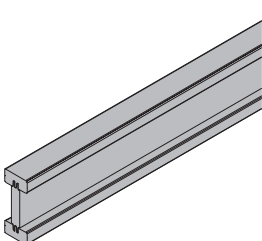
- Protect stacked beams from extreme climatic influences such as exposure to sunshine or moisture by roofing them over or covering them with breathable tarpaulins. This reduces cracking, fungal attack and mould.
- Only cover them – never envelope them completely.

	[kg]	Article N°	[kg]	Article N°
Doka beam I tec 20 1.80m	10.1	188001000		
Doka beam I tec 20 2.45m	13.7	188002000		
Doka beam I tec 20 2.65m	14.8	188003000		
Doka beam I tec 20 2.90m	16.2	188004000		
Doka beam I tec 20 3.30m	18.5	188005000		
Doka beam I tec 20 3.60m	20.2	188006000		
Doka beam I tec 20 3.90m	21.8	188007000		
Doka beam I tec 20 4.50m	25.2	188008000		
Doka beam I tec 20 4.90m	27.4	188009000		
Doka beam I tec 20 5.35m	30.0	188013000		
Doka beam I tec 20 5.90m	33.0	188010000		
Doka beam I tec 20m	5.6	188011000		
Doka-Träger I tec 20				
				
Doka beam I tec 20 12.00m	67.2	188012000		
Doka-Träger I tec 20 12,00m				
				
I tec 20 beam-end sealant 2.5l	2.5	188014000		
I tec 20-Endenversiegelung 2,5l				
				

Near to you, worldwide

Doka is one of the world leaders in developing, manufacturing and distributing formwork technology for use in all fields of the construction sector.

With more than 160 sales and logistics facilities in over 70 countries, the Doka Group has a highly efficient distribution network which ensures that equipment and

technical support are provided swiftly and professionally.

An enterprise forming part of the Umdasch Group, the Doka Group employs a worldwide workforce of more than 6000.

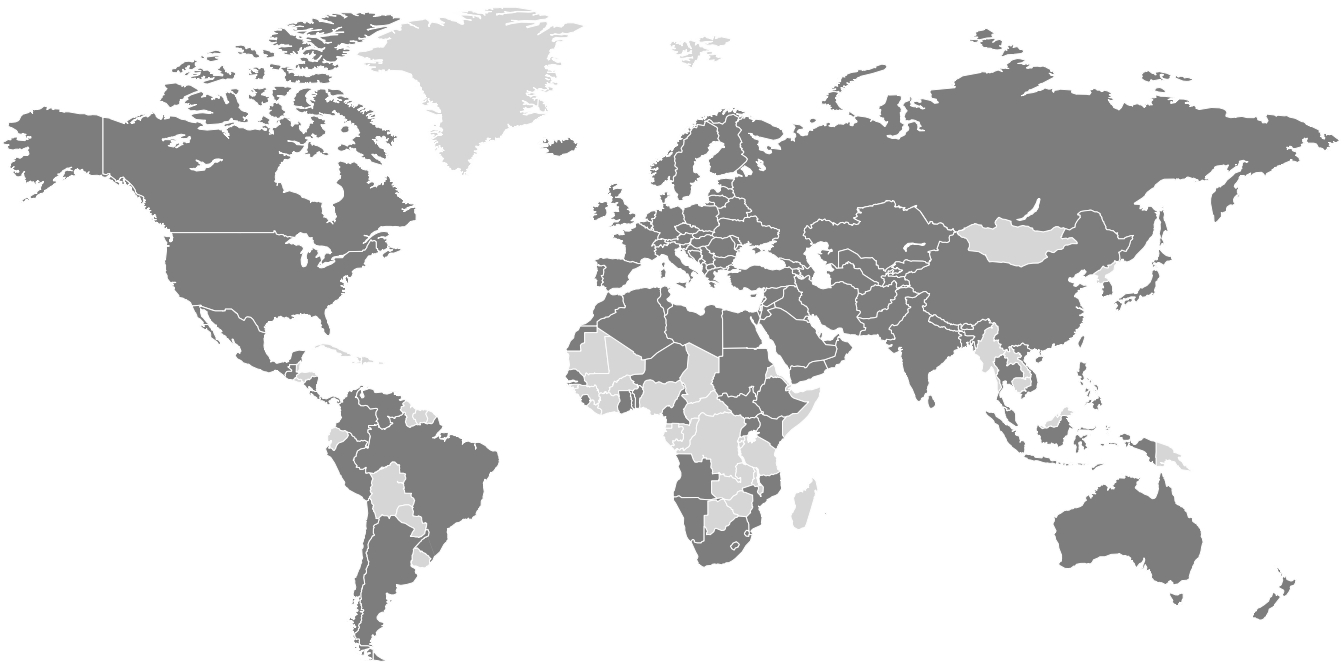

www.doka.com/composite-formwork-beams