

Panel floor formwork Dokadek 30

User Information

Instructions for assembly and use (Method statement)

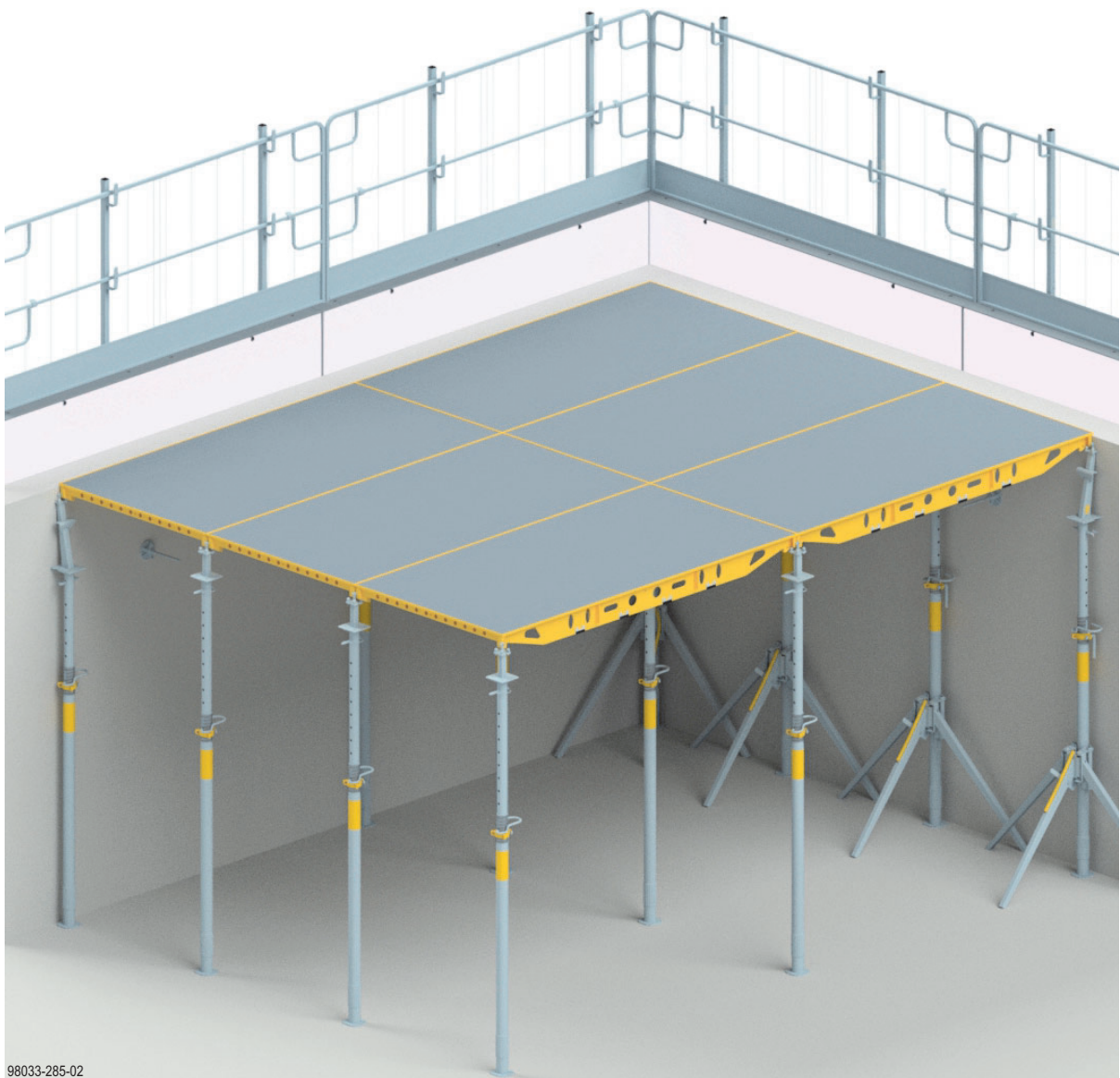

98033-285-02

Contents

4 Introduction

- 4 Elementary safety warnings
- 7 Intended use
- 8 System description

11 Instructions for assembly and use (Method statement)

- 11 Ground rules
- 19 Method statement overview
- 20 Operating with Dokadek assembling tool
- 29 Forming infill zones
- 43 Floor formwork around edges
- 54 Forming downstand beams
- 57 Early stripping without drop head without activation of the slab

59 Additional areas of use

- 59 Forming inclined floor-slabs
- 63 Additional precautions for slab thicknesses of up to 50 cm
- 66 Forming past room-high openings in walls
- 67 Using Doka floor props Eurex 20 top / eco / basic and LW

69 General

- 69 Combining with other Doka systems
- 70 Transporting, stacking and storing
- 85 Cleaning and care of your equipment
- 87 Reshoring props, concrete technology and stripping out
- 90 Horizontal loads of floor formwork

92 Article list

Introduction

Elementary safety warnings

User target groups

- This booklet is aimed at all persons who will be working with the Doka product or system that it describes. It contains information on the standard design for setting up this system, and on correct, compliant utilisation of the system.
- All persons working with the product described herein must be familiar with the contents of this booklet and with all the safety instructions it contains.
- Persons who are incapable of reading and understanding this booklet, or who can do so only with difficulty, must be instructed and trained by the customer.
- The customer is to ensure that the information materials provided by Doka (e.g. User Information booklets, Instructions for Assembly and Use, Operating Instruction manuals, plans etc.) are up to date and available to all users, and that they have been made aware of them and have easy access to them at the usage location.
- In the relevant technical documentation and formwork utilisation plans, Doka shows the workplace safety precautions that are necessary in order to use the Doka products safely in the usage situations shown.
In all cases, users are obliged to ensure compliance with national laws, standards and regulations throughout the entire project and to take appropriate additional or alternative workplace safety precautions where necessary.

Hazard assessment

- The customer is responsible for drawing up, documenting, implementing and continually updating a hazard assessment at every job-site. This booklet serves as the basis for the site-specific hazard assessment, and for the instructions given to users on how to prepare and utilise the system. It does not substitute for these, however.

Remarks on this booklet

- This document can be used as general Instructions for Assembly and Use (Method Statement) or be incorporated into site-specific Instructions for Assembly and Use (Method Statement).
- **The graphics, animations and videos in this document or app sometimes depict partially assembled assemblies and may require additional safety equipment and/or measures to comply with safety regulations.**
The customer must ensure all applicable regulations are complied with, even if they are not shown or implied in the graphics, animations and videos provided.
- **Individual sections contain further safety instructions and/or special warnings as applicable.**

Planning

- Provide safe workplaces for those using the formwork (e.g. for when it is being erected/dismantled, modified or repositioned etc). It must be possible to get to and from these workplaces via safe access routes!
- **If you are considering any deviation from the details and instructions given in this booklet, or any application which goes beyond those described in the booklet, then revised static calculations must be produced for checking, as well as supplementary assembly instructions.**

Regulations; industrial safety

- All laws, Standards, industrial safety regulations and other safety rules applying to the utilisation of our products in the country and/or region in which you are operating must be observed at all times.
- If a person or object falls against, or into, the side-guard component and/or any of its accessories, the component affected may only continue in use after it has been inspected and passed by an expert.

Rules applying during all phases of the assignment

- The customer must ensure that this product is erected and dismantled, reset and generally used for its intended purpose in accordance with the applicable laws, standards and rules, under the direction and supervision of suitably skilled persons. These persons' mental and physical capacity must not in any way be impaired by alcohol, medicines or drugs.
- Doka products are technical working appliances which are intended for industrial / commercial use only, always in accordance with the respective Doka User Information booklets or other technical documentation authored by Doka.
- The stability and load-bearing capacity of all components and units must be ensured during all phases of the construction work!
- Do not step on or apply strain to cantilevers, closures, etc. until suitable measures to ensure their stability have been correctly implemented (e.g. by tie-backs).
- Strict attention to and compliance with the functional instructions, safety instructions and load specifications are required. Non-compliance can cause accidents and severe injury (risk of fatality) and considerable damage to property.
- Sources of fire in the vicinity of the formwork are prohibited. Heaters are permissible only when used correctly and situated a correspondingly safe distance from the formwork.
- Customer must give due consideration to any and all effects of the weather on the equipment and regards both its use and storage (e.g. slippery surfaces, risk of slipping, effects of the wind, etc.) and implement appropriate precautionary measures to secure the equipment and surrounding areas and to protect workers.
- All connections must be checked at regular intervals to ensure that they are secure and in full working order.
In particular threaded connections and wedged connections have to be checked and retightened as necessary in accordance with activity on the jobsite and especially after out-of-the-ordinary occurrences (e.g. after a storm).
- It is strictly forbidden to weld Doka products – in particular anchoring/tying components, suspension components, connector components and castings etc. – or otherwise subject them to heating.
Welding causes serious change in the microstructure of the materials from which these components are made. This leads to a dramatic drop in the failure load, representing a very great risk to safety.
It is permissible to cut individual tie rods to length with metal cutting discs (introduction of heat at the end of the rod only), but it is important to ensure that flying sparks do not heat and thus damage other tie rods.
The only articles which are allowed to be welded are those for which the Doka literature expressly points out that welding is permitted.

Assembly

- The equipment/system must be inspected by the customer before use, to ensure that it is in an acceptable condition. Steps must be taken to exclude components that are damaged, deformed, or weakened due to wear, corrosion or rot (e.g. fungal decay).
- Using our safety and formwork systems together with those of other manufacturers can create risks that may lead to injury and damage to property. This requires separate verification by the user.
- The equipment/system must be assembled and erected in accordance with the applicable laws, standards and rules by trained customer personnel whilst maintaining any applicable safety inspections that may be required.
- It is not permitted to modify Doka products; such modifications constitute a safety risk.

Closing the formwork

- Doka products and systems must be set up so that all loads acting upon them are safely transferred!

Pouring

- Do not exceed the permitted fresh-concrete pressures. Over-high pouring rates overload the formwork, cause greater deflection and risk breakage.

Stripping the formwork

- Do not strip out the formwork until the concrete has reached sufficient strength and the person in charge has given the order for the formwork to be stripped out!
- When stripping out the formwork, never use the crane to break concrete cohesion. Use suitable tools such as timber wedges, special pry-bars or system features such as Framax stripping corners.
- When stripping out the formwork, do not endanger the stability of any part of the structure, or of any scaffolding, platforms or formwork that is still in place!

Transporting, stacking and storing

- Observe all country-specific regulations applying to the handling of formwork and scaffolding. For system formwork the Doka slinging means stated in this booklet must be used – this is a mandatory requirement.
If the type of sling is not specified in this document, the customer must use slinging means that are suitable for the application envisaged and that comply with the regulations.
- When lifting, always make sure that the unit to be lifted and its individual parts can absorb the forces that occur.
- Remove loose parts or secure them so that they cannot slip out of position and drop.
- When lifting formwork or formwork accessories with a crane, no persons must be carried along, e.g. on working platforms or in multi-trip packaging.
- All components must be stored safely, following all the special Doka instructions given in the relevant sections of this document!

Maintenance

- Only original Doka components may be used as spare parts. Repairs may only be carried out by the manufacturer or authorised facilities.

Miscellaneous

The weights as stated are averages for new material; actual weights can differ, depending on material tolerances. Dirt accretions, moisture saturation, etc. can also affect weight.

We reserve the right to make alterations in the interests of technical progress.

Eurocodes at Doka

The permissible values stated in Doka documents (e.g. $F_{perm} = 70$ kN) are not design values (e.g. $F_{Rd} = 105$ kN), unless specified!

- It is essential to avoid confusing permissible values with design values!
- Doka documents will continue to state the permissible values.

Allowance has been made for the following partial factors:

- $\gamma_F = 1.5$
- $\gamma_{M, timber} = 1.3$
- $\gamma_{M, steel} = 1.1$
- $k_{mod} = 0.9$

Consequently, all the design values for an EC design calculation can be determined from the permissible values.

Symbols used

The following symbols are used in this document:



DANGER

This is a notifier drawing attention to an extremely dangerous situation in which non-compliance with this notifier will lead to death or severe, irreversible injury.



WARNING

This is a notifier drawing attention to a dangerous situation in which non-compliance with this notifier can lead to death or severe, irreversible injury.



CAUTION

This is a notifier drawing attention to a dangerous situation in which non-compliance with this notifier can lead to slight, reversible injury.



NOTICE

This is a notifier drawing attention to a situation in which non-compliance with this notifier can lead to malfunctions or damage to property.



Instruction

Indicates that actions have to be performed by the user.



Sight-check

Indicates that you need to do a sight-check to make sure that necessary actions have been carried out.



Tip

Points out useful practical tips.



Reference

Cross-references other documents.

Intended use

Panel floor formwork Dokadek 30 is for the production of slabs in cast-in-place concrete construction. Dokadek 30 is designed for forming by hand.

Boundary conditions for use:

- Max. slab thickness: 50 cm
- Max. room height: 6.00 m

In special cases, boundary conditions can vary. The relevant information in the Doka technical documents must be observed.

Other use or use not in conformity with that stated above is non-intended use and requires the prior written approval of the Doka company!



In addition to this document, also follow the directions in the following User Information booklets:

- Alternative methods of assembly
- Structure edge

System description

System parts

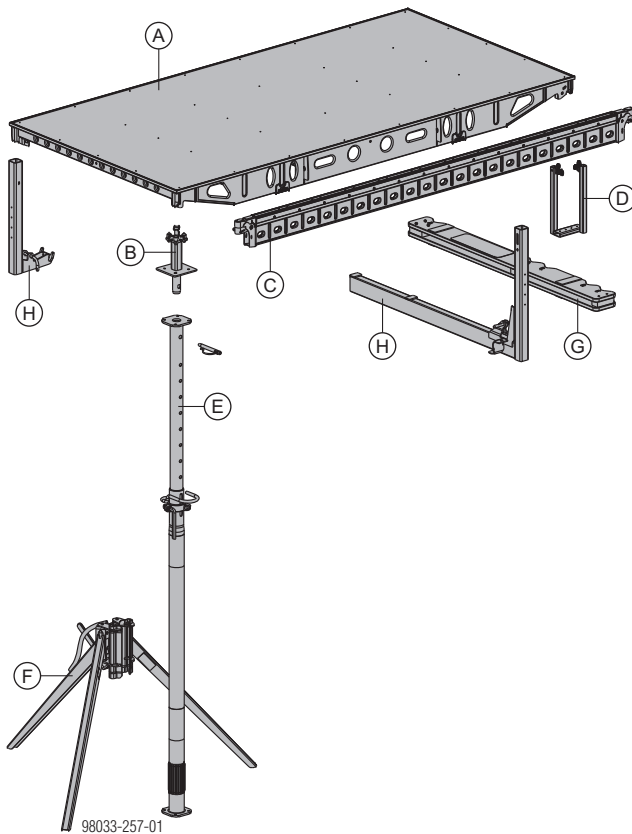

- A Dokadek panel
- B Dokadek head
- C Dokadek infill beam
- D Dokadek suspension clamp H20
- E Doka floor prop Eurex 30 top
- F Removable folding tripod
- G Dokadek wall clamp
- H Dokadek handrail-post shoes

Dokadek panels

Are galvanised, yellow coated steel frames with riveted 12 mm thick formwork sheets.

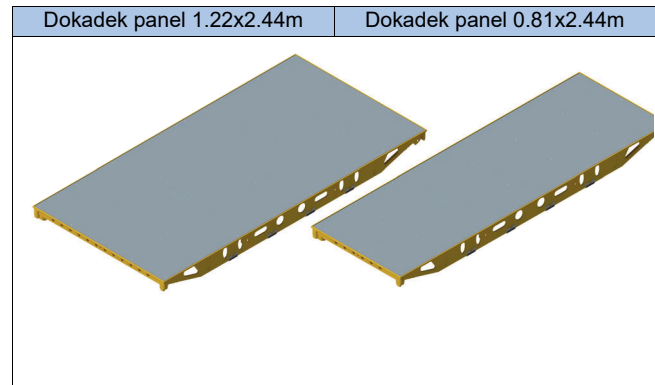

NOTICE

Impermissible areas of application for Dokadek panels 1.22x1.22m and 0.81x1.22m:

- use at the structure edge
- use with edge head, plumbing strut adapter or handrail-post shoe long

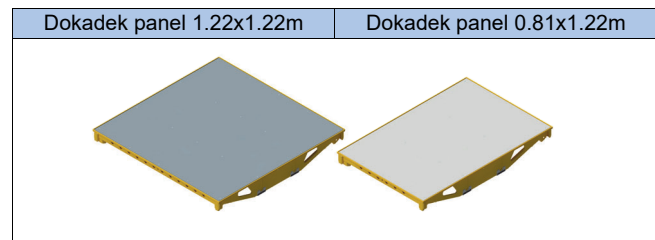

Can be used for purposes that include minimising the closure zone.

Dokadek heads



- for holding the Dokadek panels safely
- with built-in anti-liftout guards for the Dokadek panels

Support head	Edge head 18mm / 21mm / 27mm	Cross head
 1)	 1)	 1)
Corner head	Wall head	

1) Spring locked connecting pin 16mm not included with product

Dokadek infill beams

- for infilling along edges and around columns
- available for formwork-sheet thicknesses of 18mm, 21mm and 27mm
- delivered on Dokadek infill beam pallets

Infill beam 2.44m	Infill beam 1.22m	Infill beam 0.81m
		

Dokadek suspension clamp H20

These are hooked into the infill beams and make it possible to transition from the Dokadek 30 system to the Dokaflex system.



Doka floor props Eurex 30 top



- Telescopic steel prop.
- Is intended for use as a vertical prop for temporary works.
- Corresponds to the load classes in accordance with EN 1065.



Follow the directions in the 'Floor props Eurex top' User Information booklet.



WARNING

- ▶ Use with the Floor prop extension 0.50m is prohibited!

Removable folding tripod



CAUTION

Not a substitute for the bracing necessary for load-bearing towers.

- ▶ Use as a set-up aid only!



NOTICE

Do not oil or grease wedge-clamped joints.

- Fastened to the floor prop with the clamping lever.
- Set-up aid for floor props.
- Swing-out legs offer flexibility for placement where space is at a premium, for example close to walls and in corners.

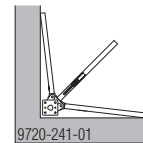

9720-241-01

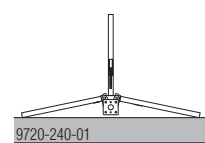

9720-240-01

- Compatible removable folding tripods:
 - Removable folding tripod top
 - Removable folding tripod 1.20m
 - Removable folding tripod eco



For possible combinations with and ways to connect to floor props see User Information booklet for the relevant floor prop type!

Dokadek wall clamp

- for holding floor props upright next to walls
- with an integrated template for measuring-up the right spacing of the floor props

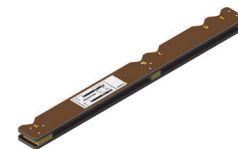

Dokadek handrail-post shoes

These are used with Handrail posts XP 1.20m or 1.80m to set up guardrail systems on the narrowside and broadside of the Dokadek panel.

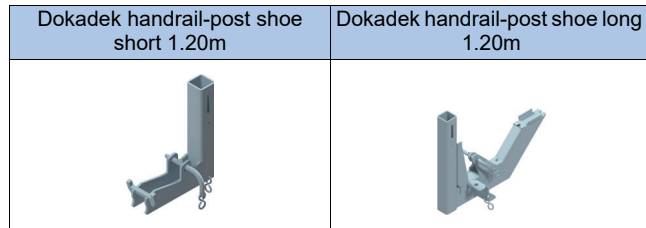
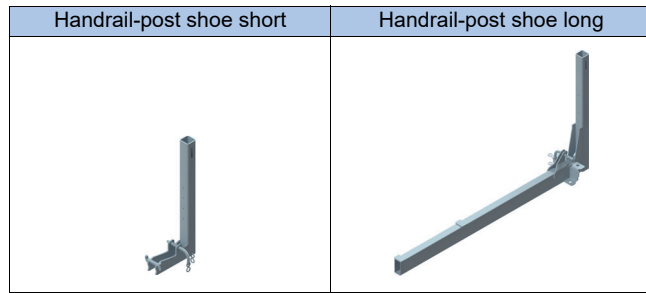

Instructions for assembly and use (Method statement)

Ground rules

Dokadek panels



NOTICE

Impermissible areas of application for Dokadek panels 1.22x1.22m and 0.81x1.22m:

- use at the structure edge
- use with edge head, plumbing strut adapter or handrail-post shoe long

Permitted slab thickness [cm]¹⁾

Panel size	without additional precautions	with additional precautions ²⁾	Flatness deviation as per DIN 18202, Table 3
1.22x2.44m	30	—	Line 6
1.22x2.44m	> 30 - 35	—	Line 5
1.22x2.44m	—	> 30 - 50	Line 6
1.22x1.22m	35	> 30 - 50	Line 5
0.81x2.44m	45	—	Line 6
0.81x2.44m	> 45 - 50	—	Line 5
0.81x2.44m	—	> 45 - 50	Line 6
0.81x1.22m	50	—	Line 6

¹⁾ when using Doka floor props Eurex 30 top or Eurex 30 eco

²⁾ See section [Additional precautions for slab thicknesses of up to 50 cm](#)

Legend

Support head	Corner head	Wall head
1)		

¹⁾ Spring locked connecting pin 16mm not included with product



NOTICE

When placing the panels onto the heads, make sure that the panels are correctly fixed in the heads.

Dokadek heads



WARNING

► The Dokadek heads must always be fixed to the floor prop with the correct pin.

Position of the Dokadek heads

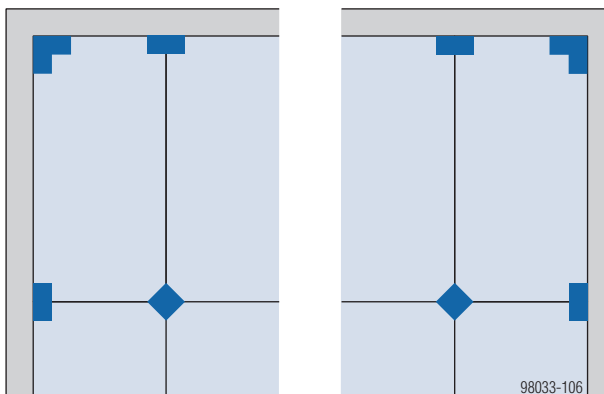

Installation examples

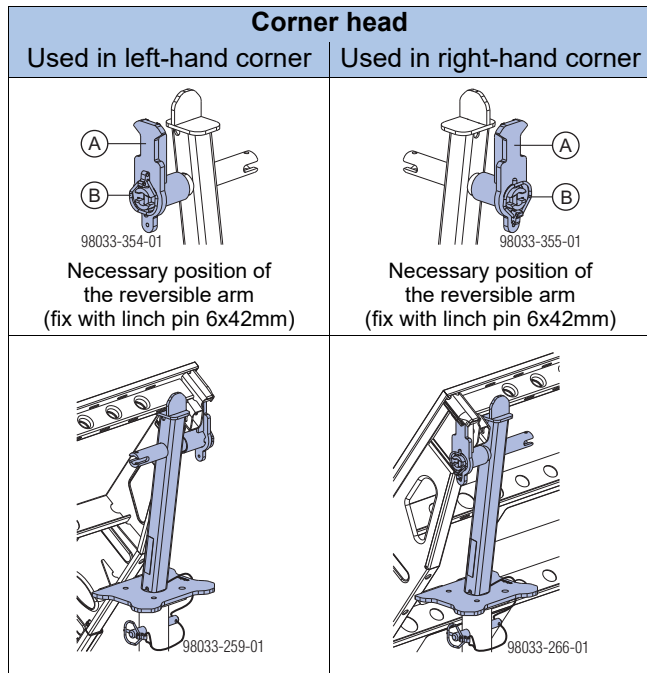
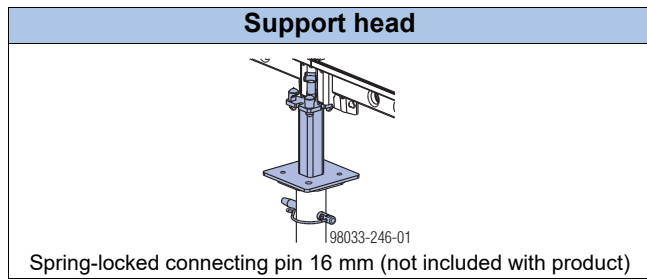

- A** Reversible arm
- B** Linch pin 6x42mm

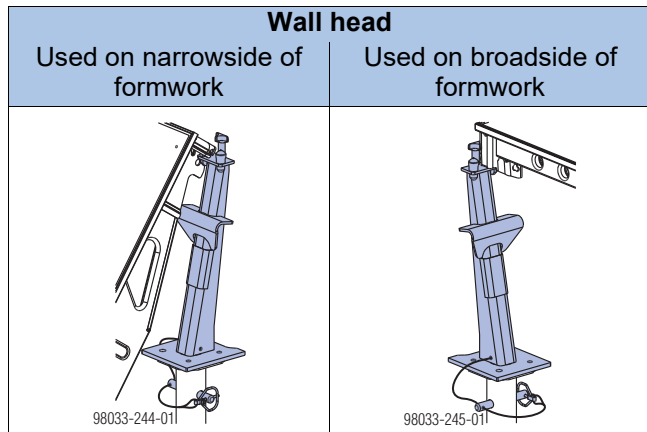

Doka floor props Eurex 30 top



WARNING

► Floor props must not be used extended to their full lengths!

This means that the props must be shortened, as follows, before being used:

For slab thicknesses of up to 32 cm:

- minus 16 cm when used with support head
- minus 40 cm when used with corner head or wall head

For slab thicknesses of > 32 - 35 cm without use of additional measures:

- minus 31 cm when used with support head
- minus 55 cm when used with corner head or wall head

Example: Floor prop Eurex 30 top 300 with support head can be extended to max. 284 cm (for a max. floor-to-ceiling height of 308.5 cm).



We recommend using props of the same type for the typical and infill zone, i.e. when combining Dokadek and Dokaflex.

Removable folding tripod



NOTICE

- Do not oil or grease the clamping mechanism of the removable folding tripod.

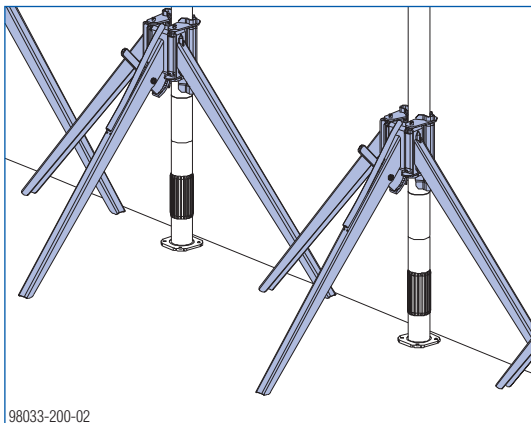

98033-200-02



CAUTION

Risk of floor props tipping over when Dokadek panel is tilted up!

- Make sure that the Removable folding tripod is facing in the right direction.
- The leg with the clamping lever must be pointing in the longitudinal direction of the panels.



► Once the 1st row of panels has been fixed (e.g. with wall clamps) so that it cannot tip over, the Removable folding tripods can be removed.

However, before the formwork is struck, the Removable folding tripods MUST be put up again!

Dokadek wall clamp

Determining the required spacing of the floor props

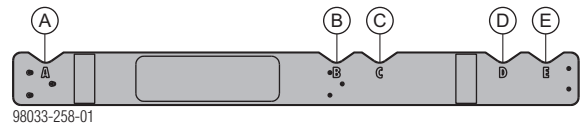

98033-258-01

Head on 1st prop is in Position A.	Width of panel to be shored	Position of 2nd prop
Corner head	0.81 m	B
Wall head	0.81 m	C
Corner head	1.22 m	D
Wall head	1.22 m	E

Practical examples

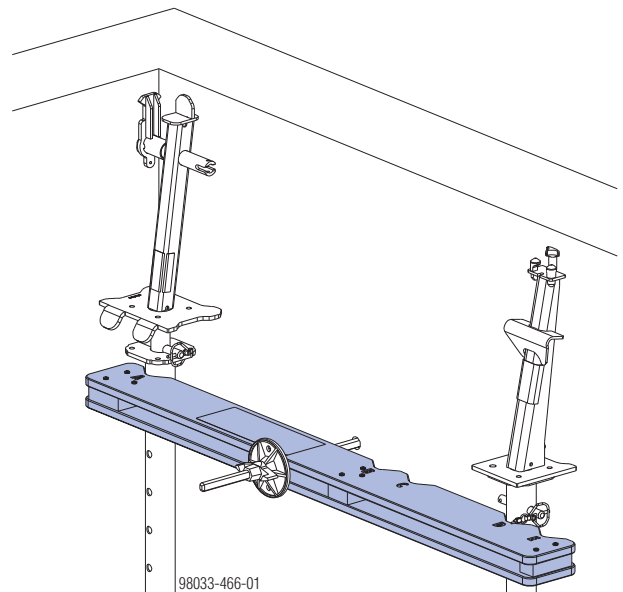

98033-466-01

Starting in a corner (with Dokadek panel 1.22x2.44m)

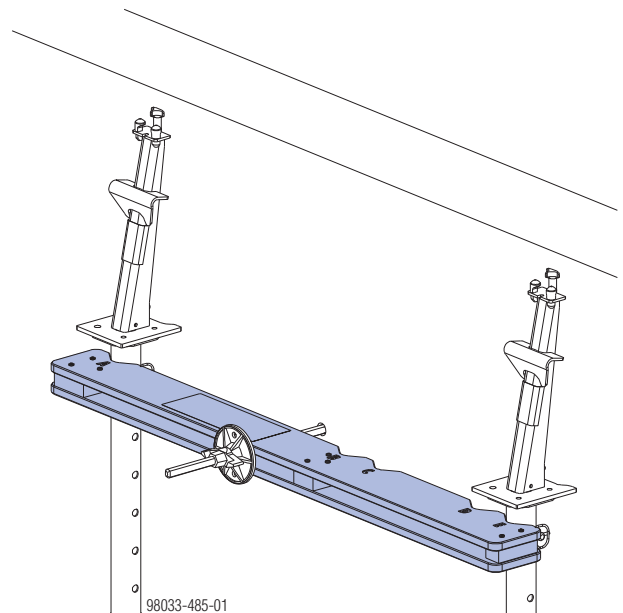

98033-485-01

Starting from a wall (with Dokadek panel 1.22x2.44m)

Stability of formwork



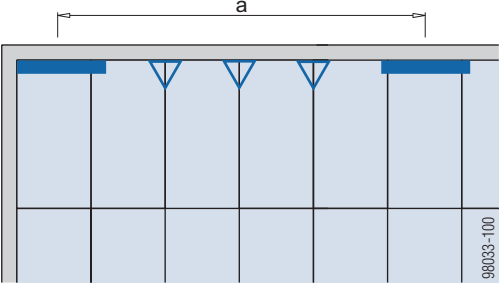
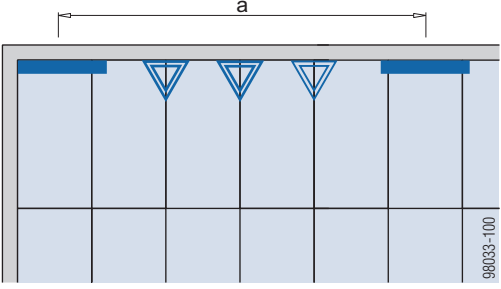
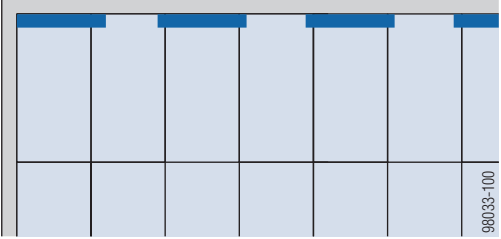
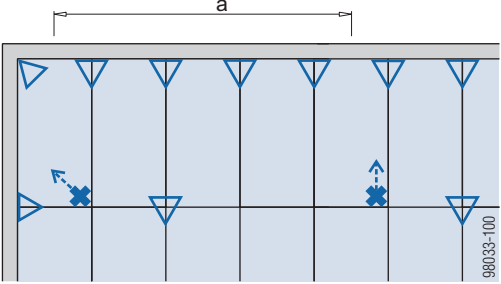

Stabilising the starting section during assembly

Starting from a wall

<p style="text-align: center;">Shoring height < 3.50 m</p> 	<p style="text-align: center;">Shoring height 3.50 - 4.00 m</p> 
<p style="text-align: center;">Shoring height > 4.00 m</p> 	<p style="text-align: center;">Special precautions e.g. if it is not possible to use a wall clamp.</p>  <p>Note: When the panels are being tilted up into the horizontal, the floor props must be given additional fixing to prevent them tipping over (i.e. the tripods alone are insufficient).</p>

a ... fixing-point on 1st panel, every max. 7.50 m **and** on last panel

Legend

	Dokadek wall clamp
	Removable folding tripod top or eco (Shoring height < 3.50 m)
	Removable folding tripod 1.20m (shoring height ≥ 3.50 m)
	Fixing point (e.g. with tie-back) Arrow = direction of the tie-back

Starting from middle of room



NOTICE

When starting from the middle of a room where it is possible to attach fixing-points to the structure, you **MUST** proceed in the following order:

1. Put up the props and secure them so that they cannot fall over.
2. Engage infill beams into the system heads, to fix the props the correct distance apart.
3. Engage the first panel into the system heads.
4. Swing panel up.
5. Fix the panel.



CAUTION

▶ When engaging and tilting up the panel, give the floor props additional fixing – i.e. as well as with the removable folding tripods – to prevent them tipping over.

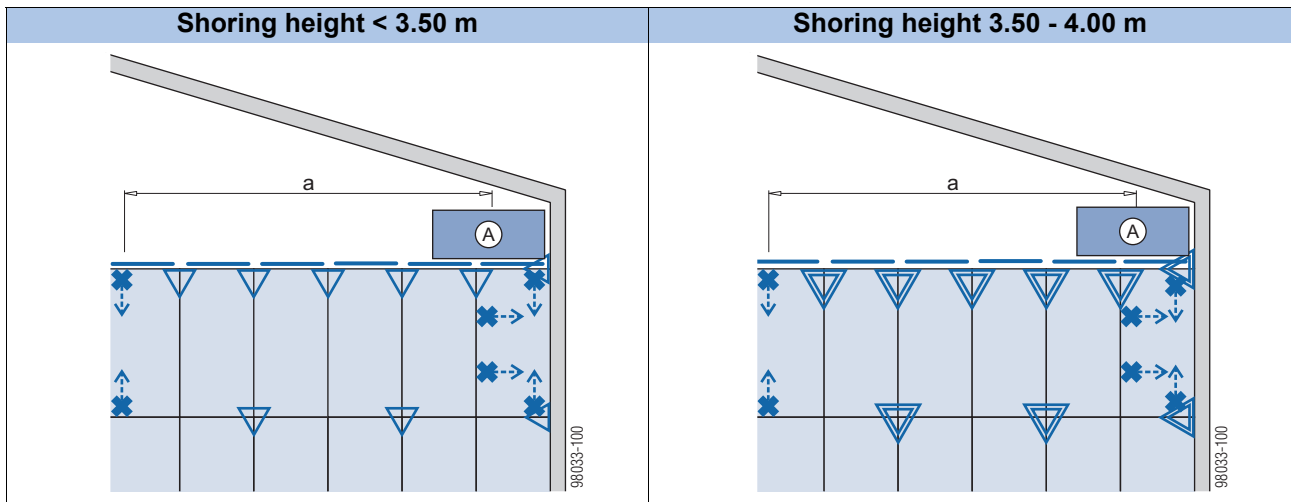

a ... fixing-point on 1st panel, every max. 7.50 m **and** on last panel

A Mobile scaffold tower, e.g. Wheel-around scaffold DF

With bracing frames Eurex

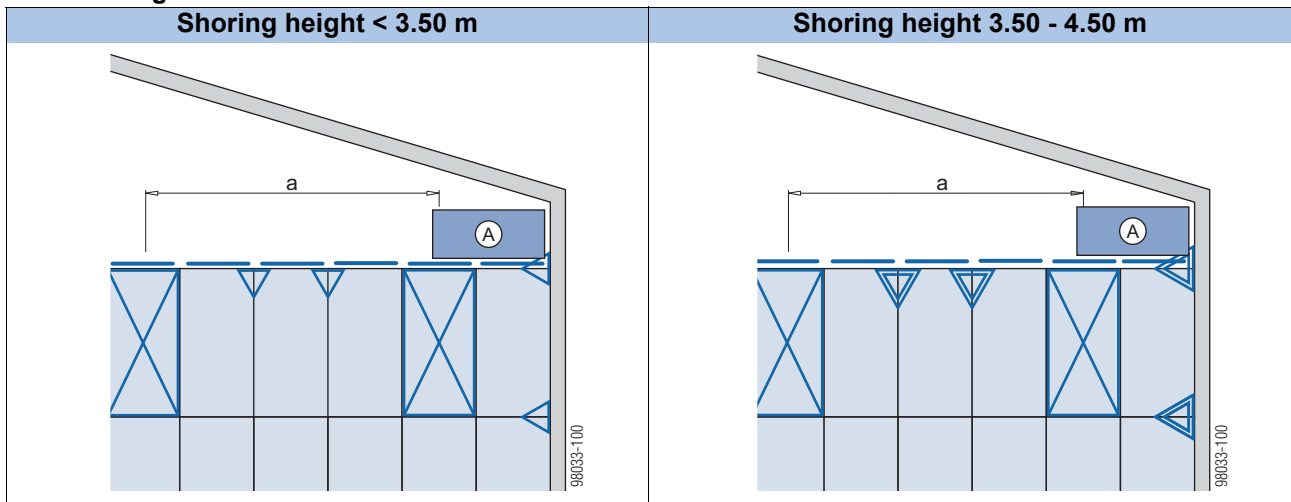

a ... 7,5 m and on last panel

A Mobile scaffold tower, e.g. Wheel-around scaffold DF

Legend

	Removable folding tripod top or eco (Shoring height < 3.50 m)
	Removable folding tripod 1.20m (shoring height ≥ 3.50 m)
	Fixing point (e.g. with tie-back) Arrow = direction of the tie-back
	Dokadek infill beam
	Bracing frames Eurex with diagonal crosses



See the 'Structure edge (Panel floor formwork Dokadek 30)' User Information booklet for information on how to start from the middle of the room if it is not possible to fix to the structure.

Rooms < 3 m wide

In rooms < 3 m wide, the removable folding tripods have to be offset in each new row of panels.

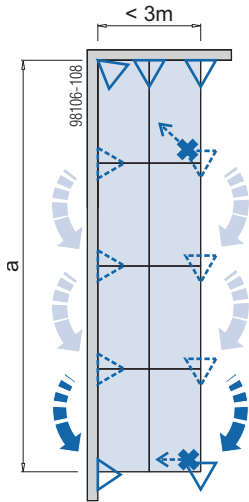

a ... Fixing to: fixing-point on 1st panel, every max. 7.50 m **and** on last panel

Legend

	Removable folding tripod top and eco
	Fixing point (e.g. with tie-back) Arrow = direction of the tie-back

Additional stabilisation during erection work

WARNING

- ▶ Before anybody steps onto the surface of the formwork, its stability must be ensured by e.g. wall clamps or lashing straps.
- ▶ Transfer of horizontal loads during pouring must be ensured by other measures (e.g. by transferring these loads into the structure or using tie-backs).

For details on how to make tie-backs with lashing straps, see section [Floor formwork around edges](#) and the 'Lashing strap 5.00m' User Information booklet.

- ▶ Formwork next to walls must be secured against tip-over as shown in the illustrations.



- ▶ Once the 1st row of panels has been fixed (e.g. with wall clamps) so that it cannot tip over, the Removable folding tripods can be removed.

However, the Removable folding tripods MUST be put up again before the formwork is stripped!

Fixing point with wall clamps

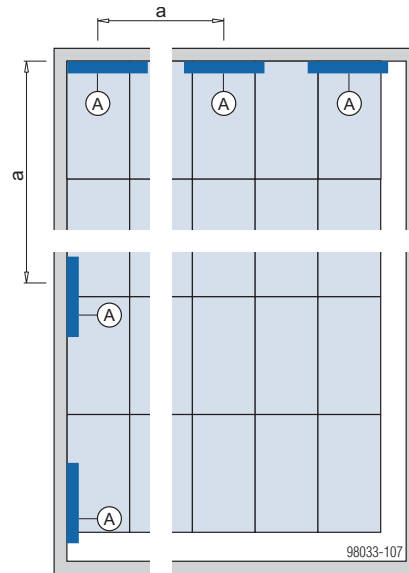

a ... fixing-point on 1st panel, every max. 7.50 m **and** on last panel

A Fixing point with wall clamps

Fixing point with lashing straps

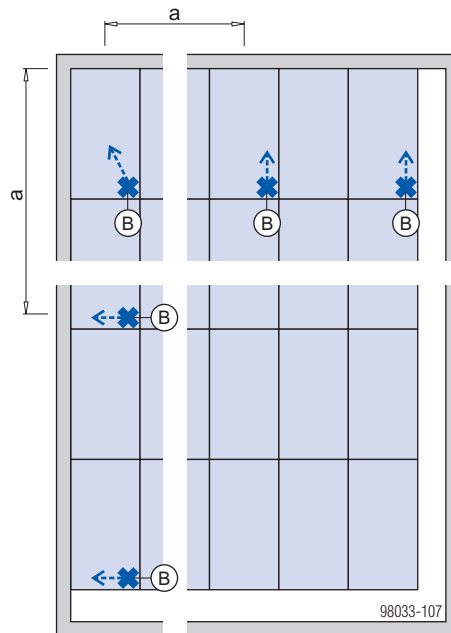

a ... fixing-point on 1st panel, every max. 7.50 m **and** on last panel

B Fixing point using lashing straps
Arrow = direction of the tie-back

Practical example
Tip-over protection using lashing straps

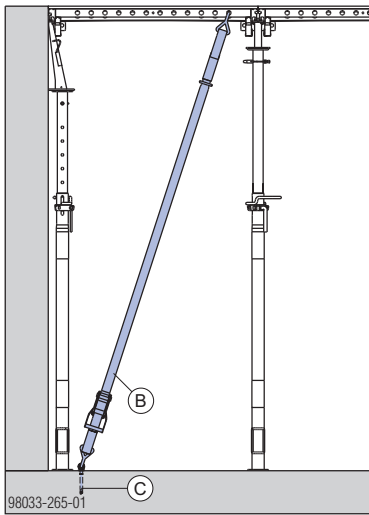

- B** Lashing strap 5.00m
- C** Doka express anchor 16x125mm



► Up to a wall thickness of 40 cm, the Lashing strap (B) can also be fixed to a wall with a Lifting rod 15.0 (D) and a Super plate 15.0 (E).

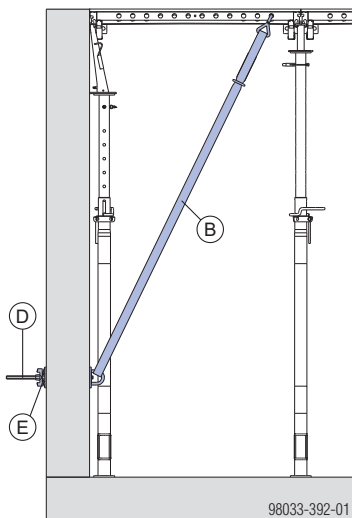

Fixing with Bracing frames Eurex

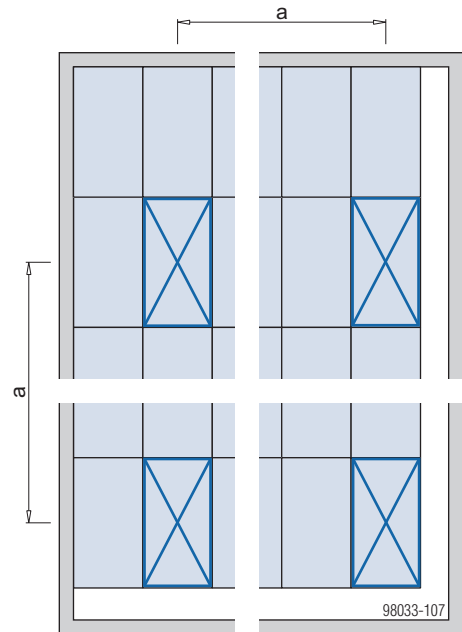

a ... max. 7.50 m **and** on last panel

Legend

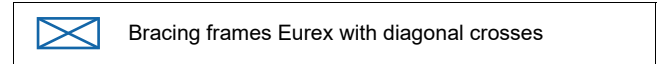

Set-up direction

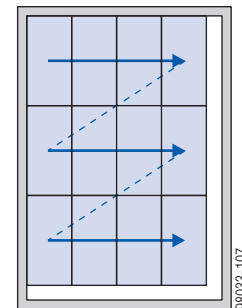

- 1) Start by setting up the panels row by row until only the planned infill zone is left unformed.
- 2) Then install the wall junctions and closures.



If necessary, you can start setting up the panels working from more than one side. The separate Dokadek sections are then joined by fillers (see section '[Forming infill zones](#)').

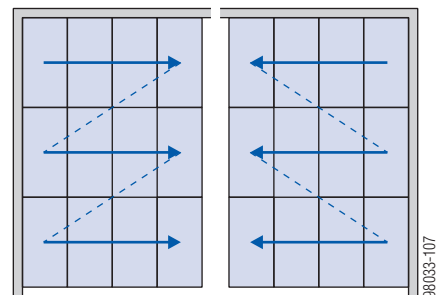

The formwork is stripped in the same way, but in reverse order.

Ladder systems and working scaffolds

Platform stairway 0.97m



- Mobile folding platform stairway made of light alloy
- Working heights of up to 3.00 m (height of top step 0.97 m)
- Stair width: 1.20 m



NOTICE

- 2 platform stairways are needed for hanging the panels into place.
- Minimum distance **a** from drop-off edge: 2.00 m

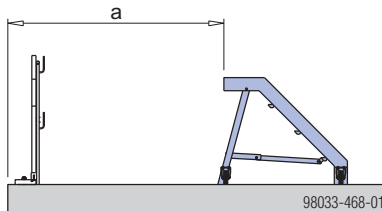

Max. load-bearing capacity: 150 kg



Follow all country-specific regulations!

Wheel-around scaffold DF



- Collapsible wheel-around platform made of light alloy
- Variable working heights of up to 3.50 m (max. platform height: 1.50 m)
- Width of scaffold: 0.75 m



NOTICE

- The Wheel-around scaffold DF is not allowed to be used for mounting and dismounting the panels.
- When work is being carried out near drop-off edges (i.e. at a distance of < 2 m), the Wheel-around scaffold DF accessory set (consisting of a toeboard and intermediate guardrail) is needed.



Follow the directions in the User Information booklet!

Ringlock



Movable working scaffold:

- Variable working heights of up to 12.0 m
- Variable scaffold width and length



Follow the directions in the User Information booklet!

Method statement overview

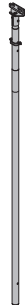
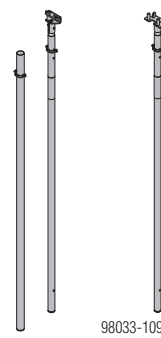
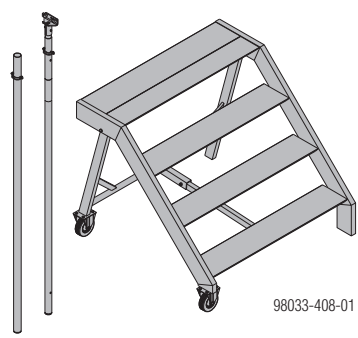
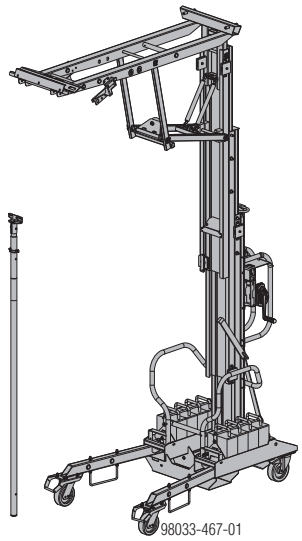
Operating with assembling tool ²⁾ or suspension tool ³⁾		Operating with DekLift 4.50m + assembling tool ²⁾	
<p>Working from the ground</p> <p>with assembling tool²⁾</p>  <p>Floor-to-ceiling height: from 2.10 m to approx. 3.50 m</p>	<p>with assembling tool²⁾ and suspension tool³⁾</p>  <p>98033-109</p> <p>Floor-to-ceiling height: from 2.10 m to approx. 4.00 m</p>	<p>Working from Platform stairway 0.97m¹⁾</p> <p>with assembling tool²⁾</p>  <p>98033-408-01</p> <p>Floor-to-ceiling height: from 2.10 m to approx. 4.20 m</p>	 <p>98033-467-01</p> <p>Floor-to-ceiling height: from 2.70 m to approx. 4.50 m</p>
<p>These methods of assembly are described in the 'Alternative methods of assembly (Panel floor formwork Dokadek 30)' User Information booklet.</p>			

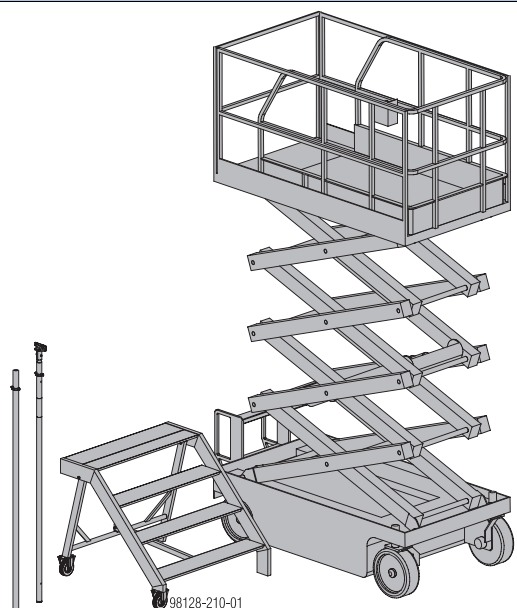
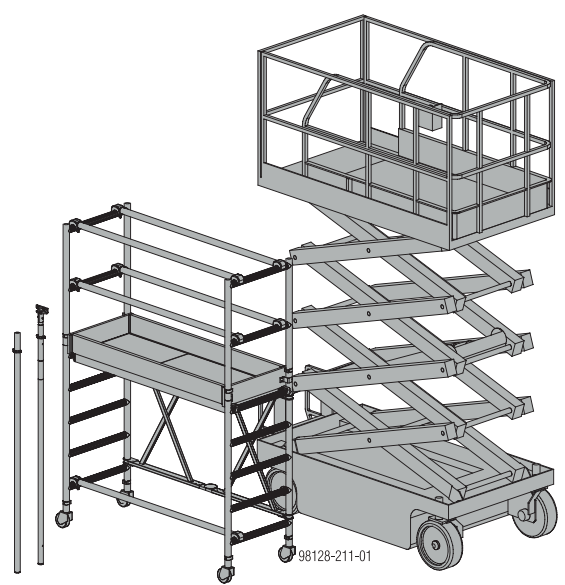
Operating with assembling tool ²⁾ , platform stairway 0.97m ¹⁾ and scissor-lift working platform	Operating with assembling tool ²⁾ , Wheel-around scaffold DF and scissor-lift working platform
 <p>98128-210-01</p> <p>Floor-to-ceiling height: up to 5.50 m</p>	 <p>98128-211-01</p> <p>Floor-to-ceiling height: up to 6.00 m⁴⁾</p>
<p>These methods of assembly are described in the 'Alternative methods of assembly (Panel floor formwork Dokadek 30)' User Information booklet.</p>	

- 1) 2 platform stairways are needed for lifting the panels and hooking them into place.
- 2) From room heights of 3.80 m upward, the assembling tool extension 2.00m is also needed.
- 3) Head part painted yellow.
- 4) For more information, please contact your Doka technician.

Operating with Dokadek assembling tool



NOTICE

As well as the instructions given here, you must follow the instructions in section [Reshoring props, concrete technology and stripping out](#).



NOTICE

For manual transport, hold the floor prop only at the outer and inner tubes.



WARNING

► Floor props must not be used extended to their full lengths!

See also section [Ground rules](#).

► Roughly adjust the height of the floor props, using the fastening clamps.

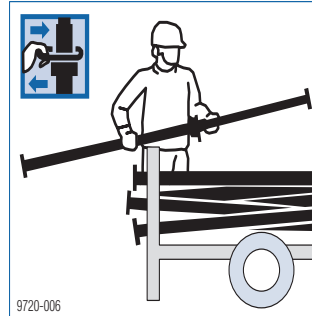

Closing the formwork

Preparations



- The fastening clamp **(A)** has to be pushed all the way into the floor prop.
- The adjusting nut **(B)** has to be tightened into contact with the fastening clamp.



- Set the **assembling tools** to the required length (= approx. room height). Min. 3 assembling tools needed per site-erection team. From room heights of 3.80 m upward, the assembling tool extension 2.00m is also needed.

Required length = room height minus 'a'

Dokadek head used		
Support head	Corner head	Wall head
a ... 25 cm	a ... 50.0 cm	a ... 50 cm
b ... room height (e.g. with Eurex 30 top 300: max. 308.5 cm) (see section Ground rules)		
c ... extension length of floor prop		

The pegging holes are all numbered, which makes it easier to adjust the props to the same height.

- Fit the Dokadek head onto the floor prop and **secure it with the pin**.

Putting up the 1st row of floor props

- ▶ Set up the removable folding tripod.



CAUTION

Risk of floor props tipping over when Dokadek panel is tilted up!

- ▶ Make sure that the Removable folding tripod is facing in the right direction.
- ▶ The leg with the clamping lever must be pointing in the longitudinal direction of the panels.

- ▶ Put up floor props (complete with corner and wall heads) directly against the wall and secure them with Removable folding tripods.
- ▶ Refer to the wall clamp to find out how far apart the floor props have to be spaced.



CAUTION

Risk of damage to the panel!

- ▶ Make sure that the tie rod does not stick out too far from the wall clamp, as this would get in the way when the panel is lifted onto the heads.

- ▶ Adjust the 1st and 2nd floor props to the right height and fix them with a wall clamp to prevent them from tipping over. To do this, mount the wall clamp as high up the wall as possible, using a tie rod and super plate. If there are tie-holes near the top of the wall, use these.

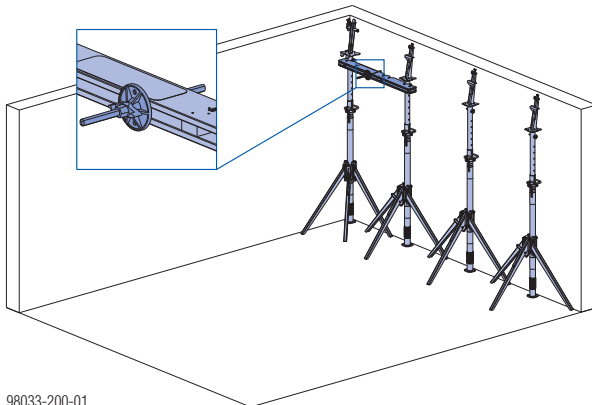

98033-200-01

Mounting the 1st row of panels

Mount the 1st panel

- ▶ Persons 1 and 2: Hook the panel onto the corner head and the wall head.

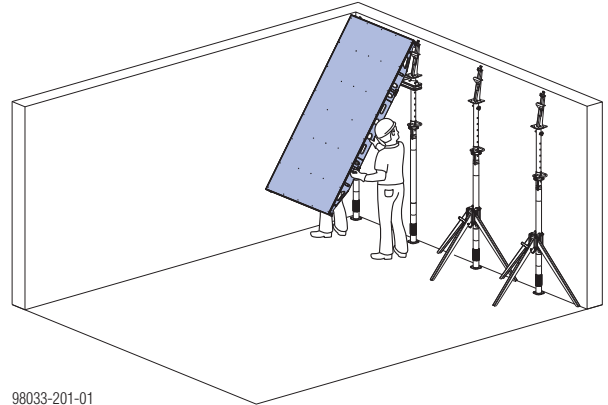

98033-201-01



Make sure that the panel is correctly engaged in both heads.

Corner head

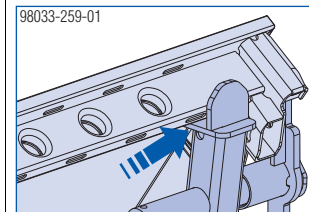

98033-259-01

Wall head

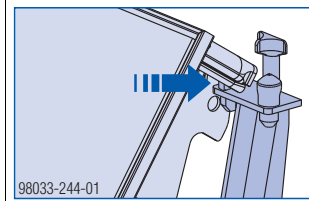

98033-244-01



For greater room heights, use an extra assembling tool (set to a shorter length) or a suspension tool for tilting up the panel.

- ▶ Person 1: Position the assembling tool that is set to a shorter length off-centre in the outside cross profile of the panel and lift up the end for propping.

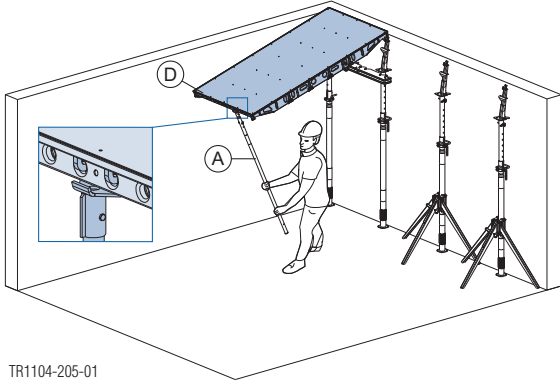

- ▶ Person 1: Place a floor prop (plus wall head) beneath the panel. The panel must still also be supported by the assembling tool. (Max. inclination of the assembling tool with respect to the perpendicular: 5°).

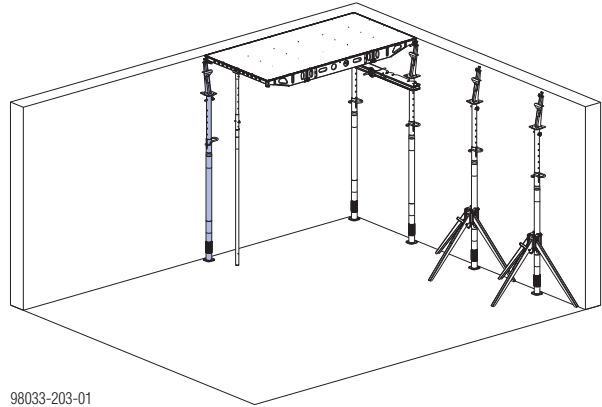

- A Assembling tool set to shorter length, or Dokadek suspension tool
- D Dokadek panel

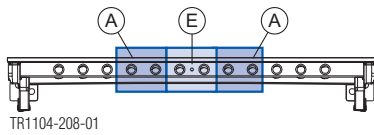

- A Position of assembling tool set to shorter length, or Dokadek suspension tool
- E Position of Dokadek assembling tool B

- ▶ Person 2: Hook the assembling tool into the middle of the outside cross profile of the panel, raise the panel and secure the assembling tool so that it cannot tip over.

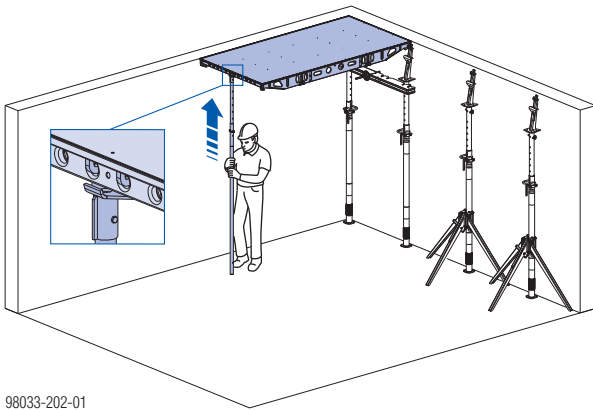

- ▶ Make sure that the panel is correctly fitted onto the pin of the head.

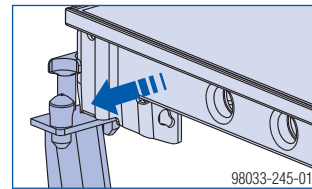

- ▶ Turn the adjusting nut on the floor prop to raise it and the corner head by 2 cm.

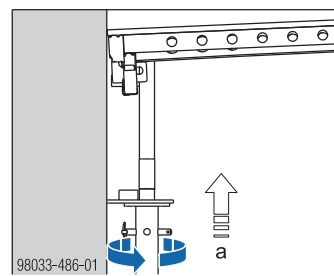

Mount further panels

- ▶ Persons 1 and 2: Hook the panel into the heads.



Make sure that the panel is correctly fitted onto the pins of both heads.

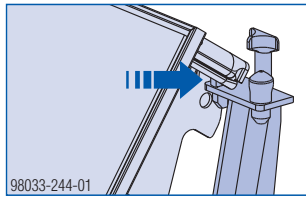

- ▶ Person 1: Tilt the panel part-way up.



For greater room heights, use an extra assembling tool (set to a shorter length) or a suspension tool for tilting up the panel.

- ▶ Person 2: Hook the assembling tool into the middle of the outside cross profile of the panel, raise the panel and secure the assembling tool so that it cannot tip over.

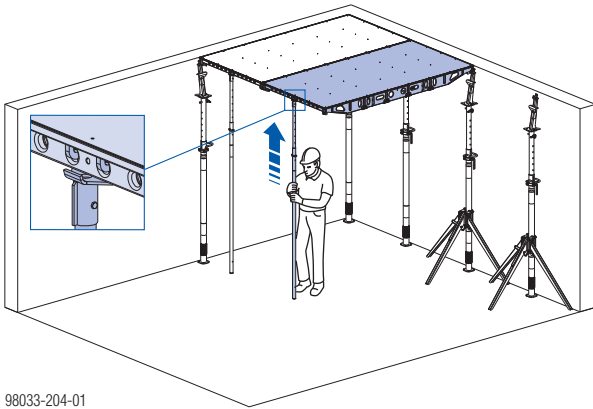

- ▶ Person 1: Place a floor prop (plus support head) beneath both panels.



Make sure that the panels are correctly fitted onto the pins of the head.

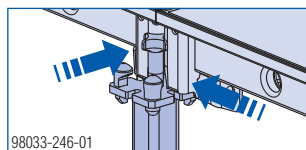

- ▶ Person 2: Remove the assembling tool from the 1st panel. The 2nd panel must still also be supported by the assembling tool. (Max. inclination of the assembling tool with respect to the perpendicular: 5°)

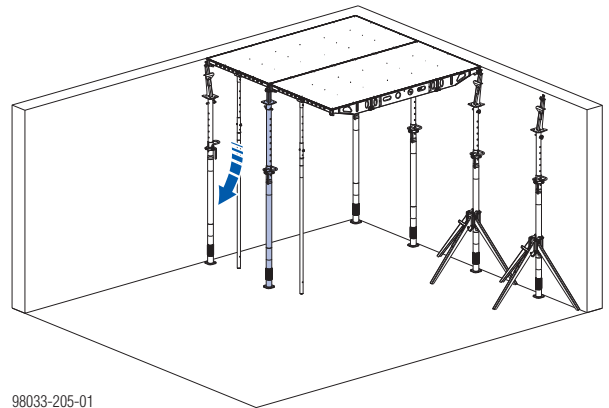

- ▶ Set up further panels in the same way, until only the planned infill zone is left unformed. Ensure stability during the set-up operations (see section [Ground rules](#))!

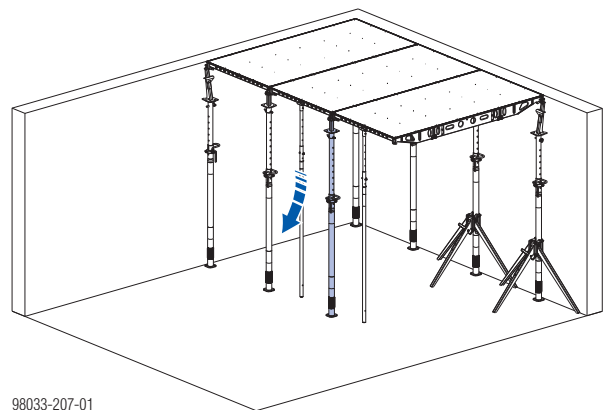
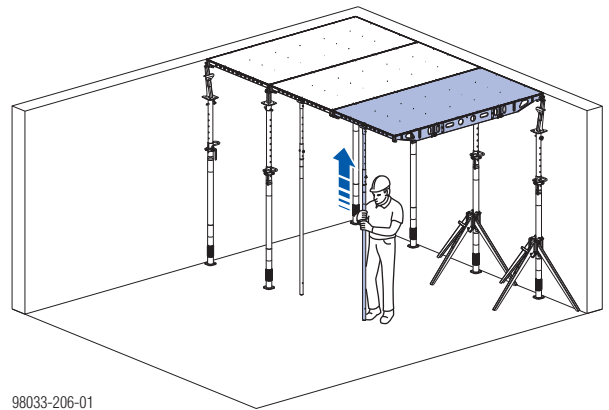

Putting up further rows of panels

- ▶ Set up further rows of panels in the same way, until only the planned infill zone is left unformed. Ensure stability during the set-up operations (see section [Ground rules](#))!

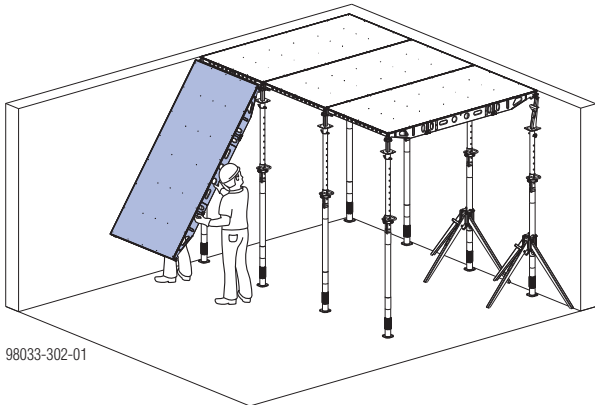

98033-302-01



Make sure that the panel is correctly engaged in both heads.

Support head

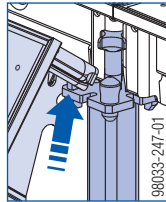

Wall head

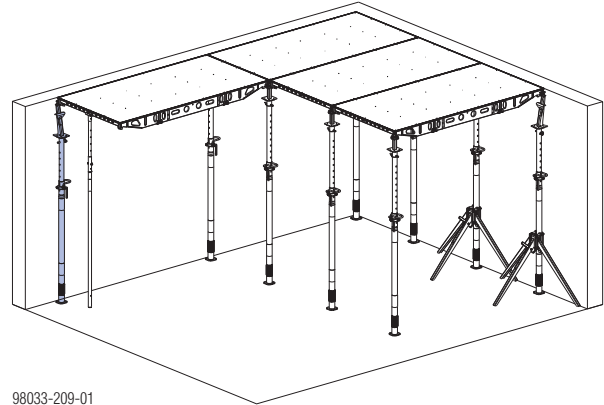
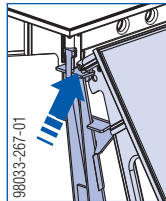

98033-209-01

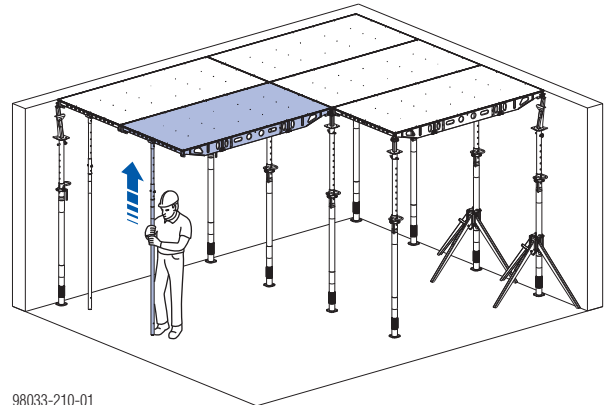

98033-210-01

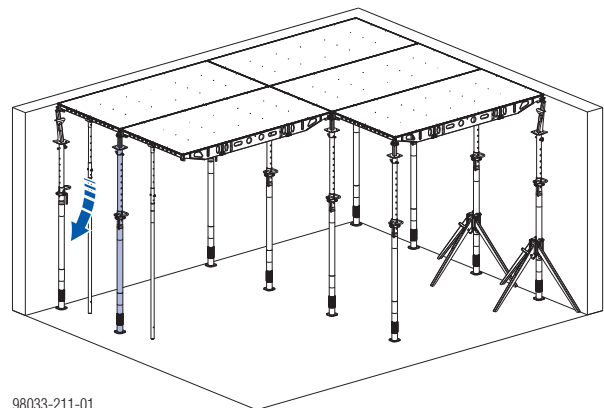

98033-211-01

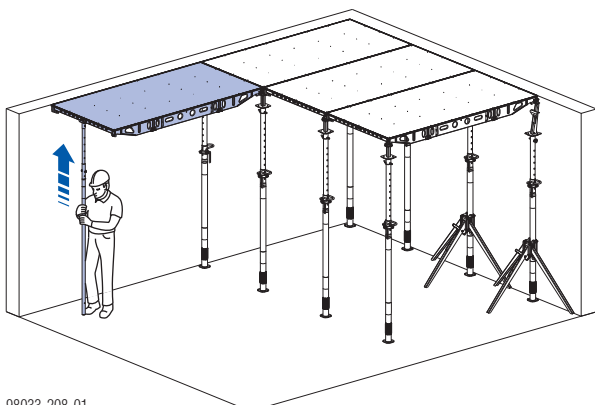

98033-208-01

Mounting the bracing frames

The Bracing frames Eurex 1.22m and 0.81m fix the Doka floor props Eurex 20 and Eurex 30 and are a stable set-up aid - especially close to the edges of floor-slab formwork.

Features:

- Suitable for fixing to both the outer and inner tubes.
- Captively integrated quick-fixing mechanism for the Doka floor props
- Can be used in combination with diagonal crosses.
- On uneven surfaces (e.g. gravel fill of load-bearing capability), higher stability is ensured during assembly.



NOTICE

- Used as a set-up aid and takes horizontal loads during assembly.
- **Not suitable** for sustaining horizontal loads during pouring.
- All the floor props must be plumb.
- The prop holders on the bracing frames must always be pointing in the same direction.

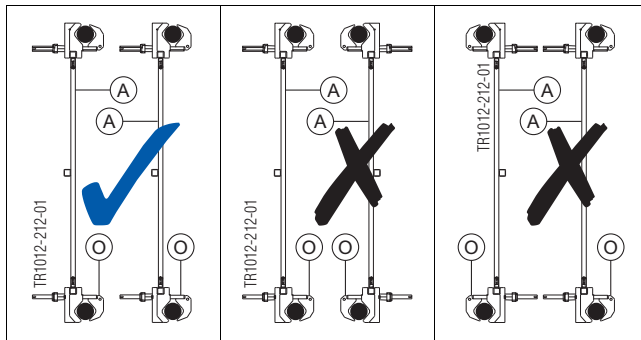

A Bracing frame Eurex

O Prop holder with quick-fixing mechanism

- Always set up the bracing frames such that the end with the two safety catches (D) and (E) is at the bottom (see Close-up A).
- It is not possible to use bracing frames directly alongside a wall.
- Use with Deklift only conditionally possible (because the bracing frame has to be removed briefly, particularly at the edge of the structure).

Area	Diagonal cross	Safety catch needed
Dokadek 30 typical zone (panel size 2.44m)	18.200	Pos. C+E
Structure edge, Dokadek 30 without drop head (panel size 2.44m)	9.175	Pos. C+E
Dokadek 30 typical zone (panel size 1.22m)	12.100	Pos. C+D



For special uses (e.g. in the infill zone), see the 'Dokaflex' User Information booklet for the necessary spacing of the bracing frames.

Close-up A

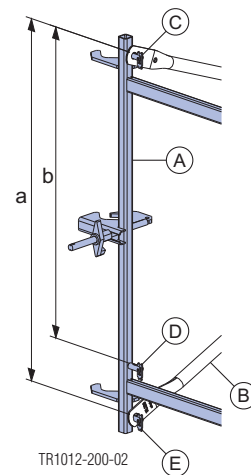

TR1012-200-02

a ... 101.9 cm

b ... 87.6 cm

A Bracing frame Eurex

B Diagonal cross

C Safety catch 1

D Safety catch 2

E Safety catch 3

- Join both Bracing frames Eurex with diagonal crosses at top and bottom, and secure these with safety catches (Close-up A).

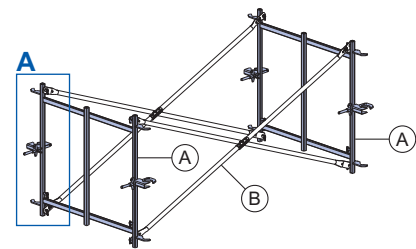

TR1012-200-01

A Bracing frame Eurex

B Diagonal cross

- ▶ Fasten floor props to the bracing frame with the quick-fixing mechanism (Close-up B).

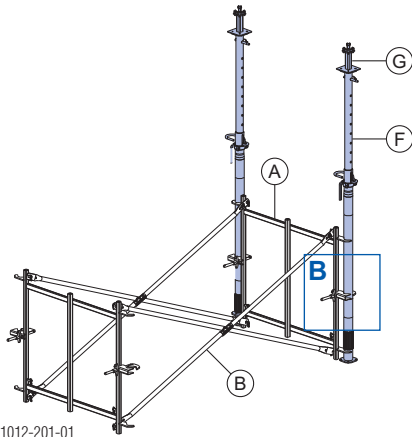

TR1012-201-01

- A Bracing frame Eurex
- B Diagonal cross
- F Doka floor prop Eurex
- G Dokadek support head

Close-up B – prop-holder

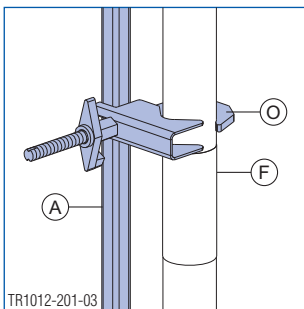

TR1012-201-03

Quick-fixing mechanism closed

- A Bracing frame Eurex
- F Doka floor prop Eurex
- O Prop holder with quick-fixing mechanism

- ▶ Engage the Dokadek panel in the support heads.

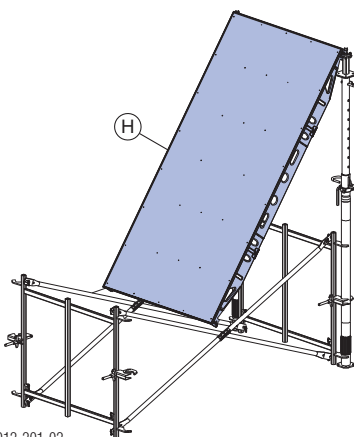

TR1012-201-02

- H Dokadek panel



Make sure that the Dokadek panels have been hung into place (engaged) correctly.

- ▶ Tilt up the Dokadek panel with an assembling tool, and put a floor prop under one of the other corners.

- ▶ Attach the floor prop to the bracing frame with the quick-fixing mechanism (the assembling tool stays in place, as it still has a shoring function. Max. inclination of the assembling tool with respect to the perpendicular: 5°).

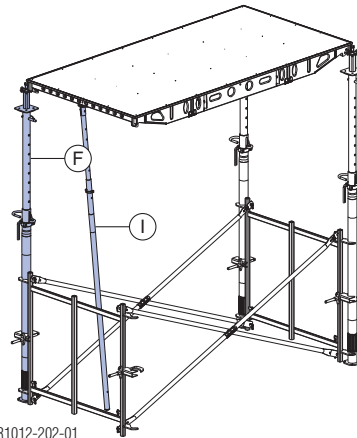

TR1012-202-01

- F Doka floor prop Eurex
- I Assembling tool

- ▶ For more steps, see section [Operating with Dokadek assembling tool](#).
- ▶ For positions and numbers of frames see the 'Structure edge (Panel floor formwork Dokadek 30)' User Information booklet.

Dismantling

- ▶ is carried out in the opposite order from assembly.

Levelling the formwork

- ▶ Adjust the panels at the corners to the desired room height minus 6.5 cm, with reference to the frame cross-profile.

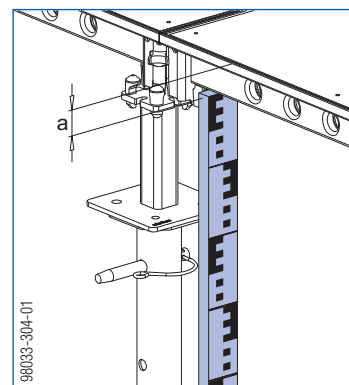

98033-304-01

a ... 6.5 cm

Additional precautions for slab thicknesses of up to 50 cm

- ▶ See section [Additional precautions for slab thicknesses of up to 50 cm](#).

Installing fall protection

- ▶ See the section headed [Fall protection on the formwork](#).

Mounting fillers

- ▶ See the section headed [Forming infill zones](#).

Pouring

- ▶ Before pouring, recheck all floor props.



- The fastening clamp (A) has to be pushed all the way into the floor prop.
- The adjusting nut (B) has to be tightened into contact with the fastening clamp.



NOTICE

Impermissible areas of application for Dokadek panels 1.22x1.22m and 0.81x1.22m:

- use at the structure edge
- use with edge head, plumbing strut adapter or handrail-post shoe long

Permitted slab thickness [cm]¹⁾

Panel size	without additional precautions	with additional precautions ²⁾	Flatness deviation as per DIN 18202, Table 3
1.22x2.44m	30	—	Line 6
1.22x2.44m	> 30 - 35	—	Line 5
1.22x2.44m	—	> 30 - 50	Line 6
1.22x1.22m	35	> 30 - 50	Line 5
0.81x2.44m	45	—	Line 6
0.81x2.44m	> 45 - 50	—	Line 5
0.81x2.44m	—	> 45 - 50	Line 6
0.81x1.22m	50	—	Line 6

¹⁾ when using Doka floor props Eurex 30 top or Eurex 30 eco

²⁾ See section [Additional precautions for slab thicknesses of up to 50 cm](#).

To protect the surface of the form-facing, we recommend using a vibrator with a protective rubber cap.

Stripping the formwork



NOTICE

- Comply with the stipulated stripping times.
- Always strip out the formwork in reverse order.
- As well as the instructions given here, you must follow the instructions in section [Reshoring props, concrete technology and stripping out](#).



The Dokadek stripping tool (A) provides an easy, safe way of detaching panels from the concrete where necessary.

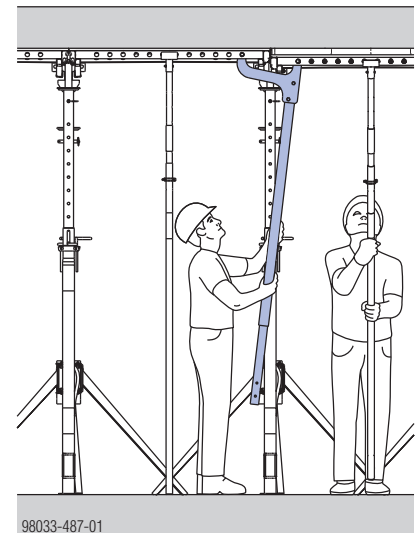

Used on Dokadek panels 1.22x2.44m

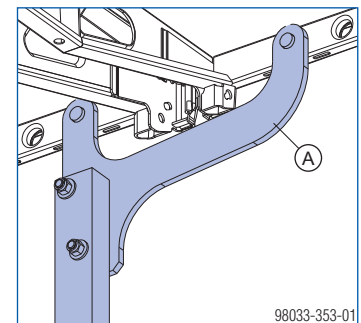

Used on Dokadek panels 0.81x2.44m

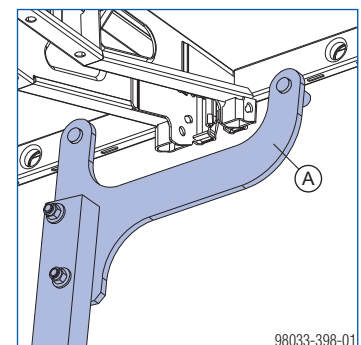

Preparations



NOTICE

- ▶ Before striking the formwork, make sure that the floor props in the last row of panels to be struck are still fixed with removable folding tripods or wall clamps.
- ▶ Set the **assembling tools** to the required length (= approx. room height). Min. 3 assembling tools needed per site-erection team.
From room heights of 3.80 m upward, the assembling tool extension 2.00m is also needed.
- ▶ Secure the panels so that they cannot suddenly drop.
- ▶ Lower the floor formwork in the infill zone (floor props underneath infill beams approx. 2 cm).
- ▶ Remove the Doka beam H20.
- ▶ Remove the infill beams, for example using a working scaffold for access.

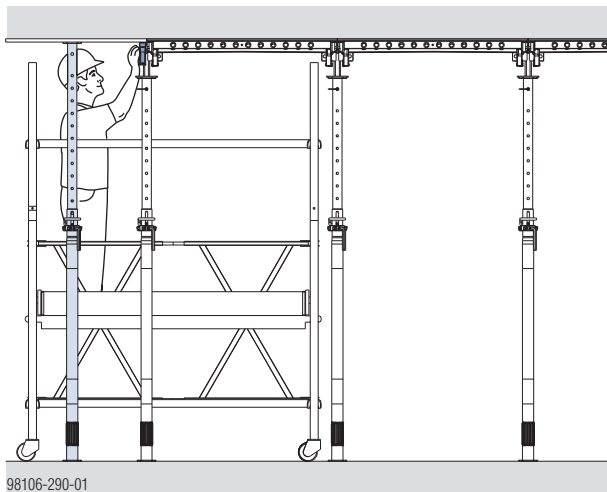

- ▶ Remove the panels.

Dismantling the floor props and panels



NOTICE

- ▶ Loosen the adjusting nut with a blow of the hammer and turn the floor prop to lower it.
- ▶ Lower the props in the first row of panels to be stripped out, by approx. 2 cm (= approx. 1 turn of the adjusting nut).

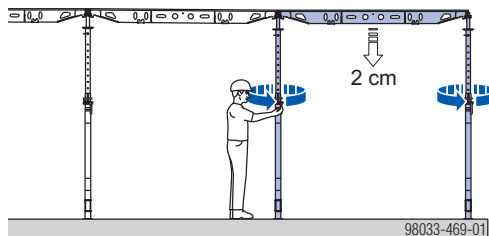

- ▶ Place assembling tools beneath the 1st and 2nd panels. (Max. inclination of the assembling tool with respect to the perpendicular: 5°)
- ▶ Remove the 1st and 2nd floor props and place them in a stacking pallet.



NOTICE

- ▶ Bring the floor prop into a horizontal position.
- ▶ If necessary, open the fastening clamp and push the inner tube into the outer tube.
- ▶ Lay the floor prop on the stacking pallet.



CAUTION

- ▶ Use only the Dokadek stripping tool to release the panels from the concrete.

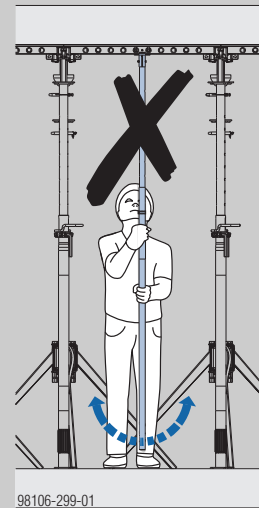

- ▶ Using the assembling tool, lower the panel until the 2nd person can take hold of it and tilt it all the way down.
- ▶ Lift the panel off the prop-heads and set it down.
- ▶ Place the assembling tool beneath the 3rd panel, remove the 3rd floor prop and place it in the stacking pallet. (Max. inclination of the assembling tool with respect to the perpendicular: 5°)
- ▶ Unhook the 2nd panel and place it on a panel pallet.
- ▶ Take down all the other panels in the same way.

Cleaning the formwork

- ▶ See the section headed [Cleaning and care of your equipment](#).

Reshoring

- ▶ Before pouring the next floor-slab (i.e. above the one that has just been stripped), put up reshoring props.
- ▶ See the section headed [Reshoring props, concrete technology and stripping out](#).

Forming infill zones



NOTICE

- Ideally, fillers should be mounted from below (e.g. from a Wheel-around scaffold DF).
- If fillers have to be mounted from above, the crew must use a personal fall-arrest system (e.g. safety harness).
- Suitable anchorage points must be defined by an approved person appointed by the contractor.

Areas where infills may be needed:

- at wall connections
- between 2 Dokadek forming-sections
- around columns



WARNING

Falling hazard! Do not step onto loose sheets and infill beams!

- Only step onto these once the entire infill zone has been closed and secured by nailing!

Recommended nail lengths:

Sheet thickness of 18 mm: approx. 60 mm

Sheet thickness of 21 mm: approx. 65 mm

Sheet thickness of 27 mm: approx. 70 mm

Dokadek system components for infill zones

Dokadek panel 0.81x2.44m

If Dokadek panels 1.22x2.44m are combined with Dokadek panels 0.81x2.44m, the max. infill width can generally be reduced to 41 cm.

The Dokadek panels 0.81x2.44m are mounted in the same way as the Dokadek panels 1.22x2.44m.

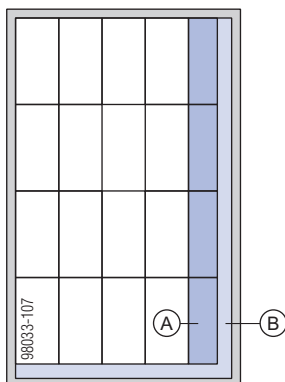

A Dokadek panel 0.81x2.44m

B Infill zone (max. width 41 cm)

Dokadek cross head to reduce the infill zone

The width of the infill zone can be reduced by turning the panels in the first row. The Dokadek cross head is used for this purpose.

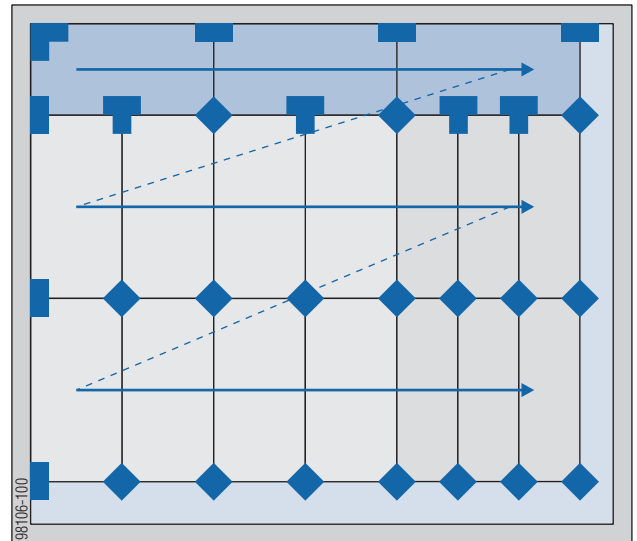

Legend

Support head	Corner head	Wall head	Dokadek cross head
1)			1)

1) Spring locked connecting pin 16mm not included with product

Installation of Dokadek cross head



NOTICE

- ▶ Props with a cross head should only be extended (by turning the adjusting nut) until the prop encounters resistance from above. The panel must not be raised.
- ▶ At the corners, use tripods to secure those floor props that have only 1 panel resting on the heads.

- ▶ Shore the panels with floor props and cross heads at the required position.

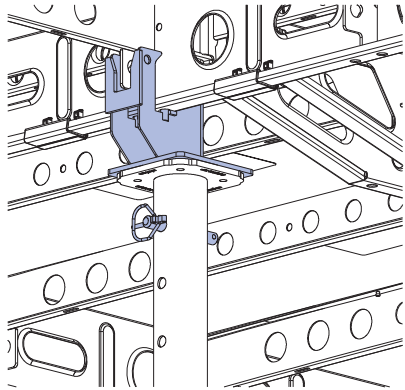

The pins of the cross head must be fitted into the two holes in the panel.

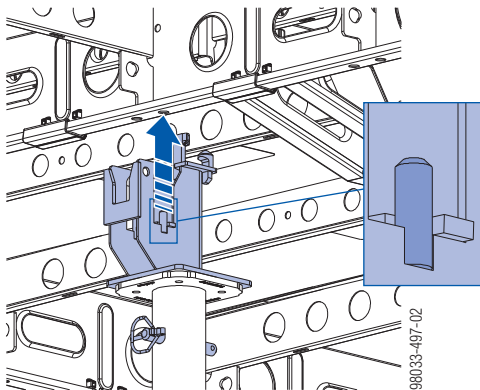

Dokadek infill beams

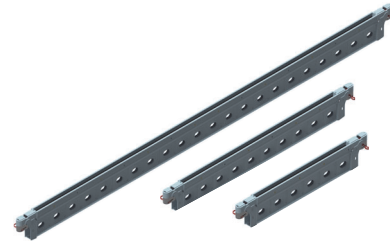

- Permissible moment: 5 kNm
- Permissible shear force: 11 kN
- Flexural rigidity EI: 320 kNm²
- Permissible reaction load where supported by floor prop in mid-span: 22 kN

Identification mark (D) on infill beam to show matching sheet thickness

Sheet thickness		
18 mm	21 mm	27 mm

Adjusting the Dokadek infill beams

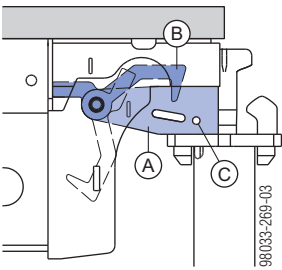
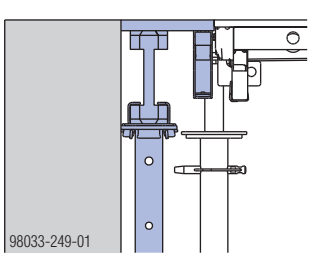
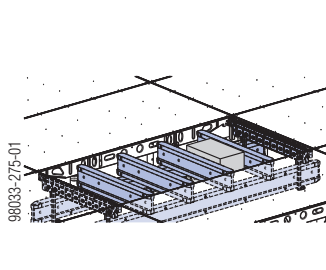
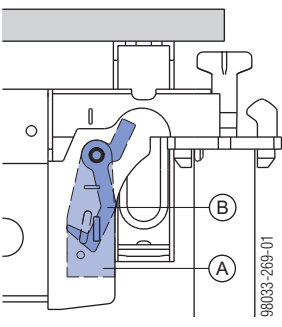
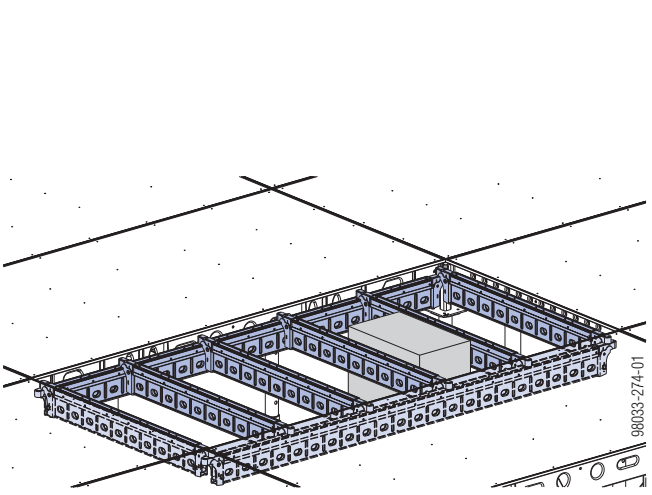
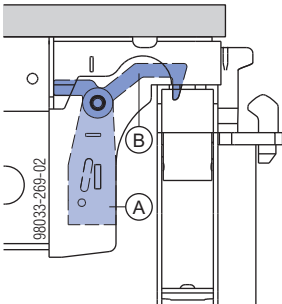
Area of use		Practical examples	
	<p>Infill zone against a wall or around columns, using Doka beams H20: cheek plate at top, locking mechanism at top or bottom</p>  <p>98033-269-03</p>	 <p>98033-249-01</p>	 <p>98033-275-01</p>
<p>Infill zone around columns, using Dokadek infill beams</p>	<ul style="list-style-type: none"> ▪ Infill beams used as primary beams: cheek plate at bottom, locking mechanism at bottom  <p>98033-269-01</p>	 <p>98033-274-01</p>	
	<ul style="list-style-type: none"> ▪ Infill beams used as secondary beams: cheek plate at bottom, locking mechanism at top  <p>98033-269-02</p>		

- A** Cheek plate (silver)
- B** Locking mechanism (red)
- C** Position for optional extra anti-liftout guard with spring cotter (included with product)

Dokadek suspension clamp H20



Permissible reaction force: 11 kN

Note:

The Suspension clamp H20 does not need to be supported by any extra floor prop.

Infilling along wall connections

Variant 1: Infill width 'a' = 17 - 35 cm

- max. spacing of infill props (Eurex 30): 244 cm
- Max. slab thickness: 50 cm

Assembly:

- ▶ Hook the infill beams into the support heads (cheek plate at top).

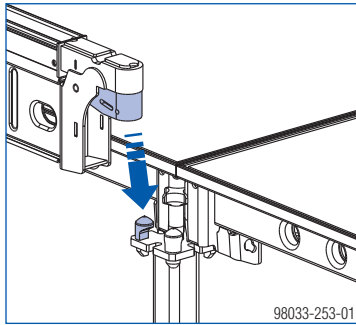

- ▶ Mount the fillers.

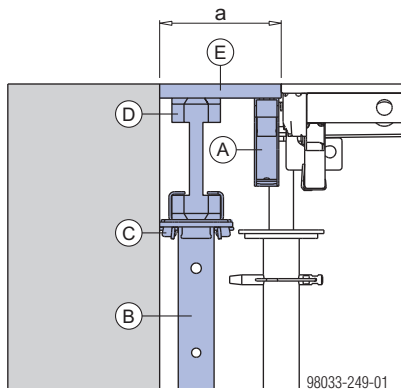

- A Dokadek infill beam
- B Doka floor prop Eurex 30 top + Removable folding tripod
- C Supporting head H20 DF
- D Doka beam H20 where infill width 'a' is ≥ 17 cm (infill gaps of less than 17 cm can be made up in-situ with a plank or squared timber)
- E Formwork sheeting



NOTICE

Put up the intermediate props so that they force-fit. It is not allowed to make some props higher than others!

Variant 2: Infill width 'a' = 32 - 59 cm

Max. infill width 'a' for slab thicknesses of up to 35 cm

Sheet thickness	Type of sheet	
	Doka formwork sheet 3-SO ¹⁾	Multi-ply sheet ²⁾
18 mm	—	53 cm
21 mm	38 cm	60 cm
27 mm	59 cm	—

▪ max. spacing of infill props (Eurex 30): 244 cm

Max. infill width 'a' for slab thicknesses of up to 50 cm

Sheet thickness	Type of sheet	
	Doka formwork sheet 3-SO ¹⁾	Multi-ply sheet ²⁾
18 mm	—	52 cm
21 mm	35 cm	58 cm
27 mm	52 cm	—

▪ max. spacing of infill props (Eurex 30): 244 cm

¹⁾ The computed values apply to the secondary (i.e. weaker) load-bearing direction, with the longitudinal direction of the sheet parallel to the edge of the floor-slab.

²⁾ Mean flexural modulus of elasticity where sheet moisture content is $10\pm 2\%$: ≥ 5600 N/mm²
 Characteristic flexural strength where sheet moisture content is $10\pm 2\%$: ≥ 19 N/mm²

Assembly:

- ▶ Hook the infill beams into the support heads (cheek plate at top).

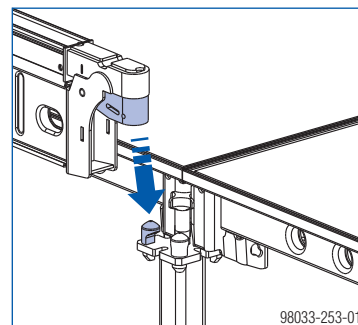

- ▶ Mount the fillers.

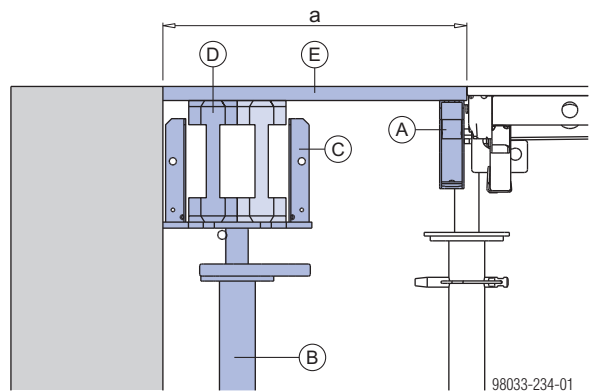

- A Dokadek infill beam
- B Doka floor prop Eurex 30 top + Removable folding tripod
- C Lowering head H20
- D Doka beam H20 (telescoped)
- E Formwork sheeting

Variant 3: Infill width 'a' = 55 - 270 cm

Infill width 'a' for slab thicknesses of up to 35 cm

Primary beam	Infill width 'a'	Recommended secondary beam
1.10 m	55 - 100 cm	2.90 m
1.80 m	90 - 170 cm	
2.90 m	145 - 270 cm	

- Eurex 30:
- max. prop spacing 'b': 70 cm
 - max. primary-beam spacing: 244 cm
 - max. secondary-beam spacing: 50 cm (Do not exceed the max. support centres of the formwork sheets!)
 - for infill gaps 'a' ≥ 100 cm: intermediate prop (with Supporting head H20) is required

Infill width 'a' for slab thicknesses of up to 50 cm

Primary beam	Infill width 'a'	Recommended secondary beam
1.10 m	55 - 100 cm	2.90 m
1.80 m	90 - 170 cm	
2.90 m	145 - 270 cm	

- Eurex 30:
- max. prop spacing 'b': 50 cm
 - max. primary-beam spacing: 244 cm
 - max. secondary-beam spacing: 42 cm (Do not exceed the max. support centres of the formwork sheets!)
 - for infill gaps 'a' ≥ 75 cm: intermediate prop (with Supporting head H20) is required

Assembly:

- Hook the infill beams into the support heads (cheek plate at top).

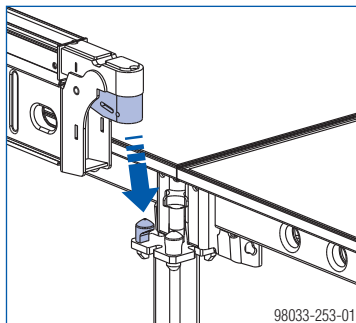

- Hook the suspension clamps into the infill beams as close to the floor props as possible.

Number of suspension clamps needed:

- next to every floor prop in the longitudinal direction
- next to every other floor prop in the transverse direction

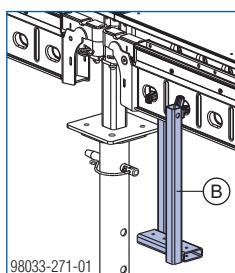

- Mount the fillers.

Practical example: Infill width 'a' ≤ 100 cm

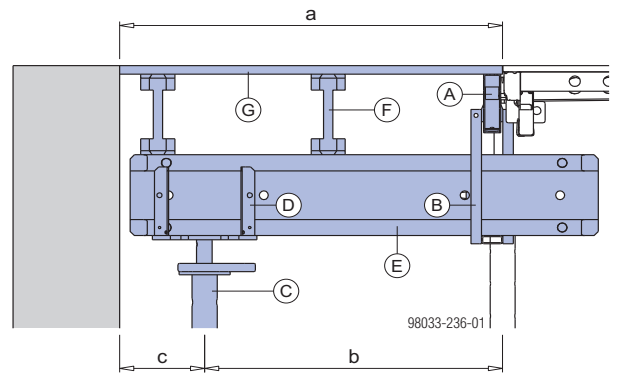

c ... 35 cm (up to slab thickness of 35 cm), 25 cm (slab thickness > 35 cm and up to 50 cm)

Practical example: Infill width 'a' > 100 cm (with intermediate prop)

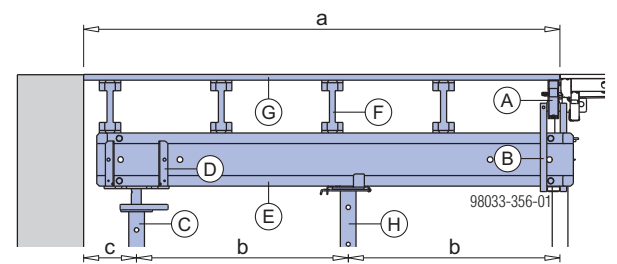

c ... 35 cm (up to slab thickness of 35 cm), 25 cm (slab thickness > 35 cm and up to 50 cm)

- A Dokadek infill beam
- B Dokadek suspension clamp H20
- C Doka floor prop Eurex 30 top + Removable folding tripod
- D Lowering head H20
- E Doka beam H20 as primary beam
- F Doka beam H20 as secondary beam
- G Formwork sheeting
- H Intermediate prop with Supporting head H20



Place a beam (or double beam) wherever there is to be a joint between the panels.

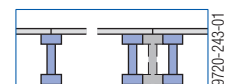

NOTICE

Put up the intermediate props so that they force-fit. It is not allowed to make some props higher than others!

Dokadek infill-beam shoes

2 Dokadek infill-beam shoes 18mm or 21mm can be used in combination with a squared timber to create economical beams as an alternative to the conventional infill beams.

These beams can be used for closures of up to 50 cm at wall junctions in the Panel floor formwork Dokadek 30 system.

Features:

- For form-ply thicknesses of 18 mm and 21 mm
- Can be used with support head, wall head and XF drop head.
- The squared timber 200 x 40 mm is not included in the scope of supply!



NOTICE

Use at the structure edge in combination with edge heads or XF edge heads is not possible!

Use with support head

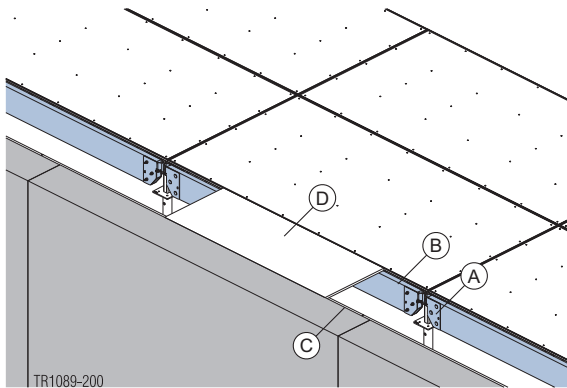

Close-up

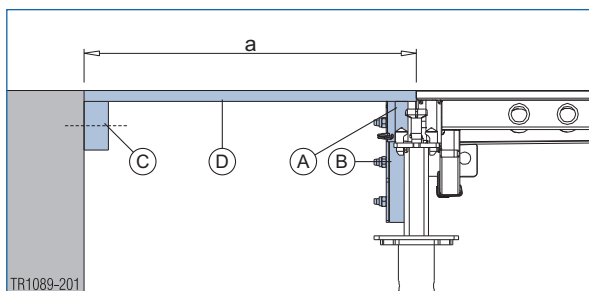

a ... max. 45 cm (up to slab thickness of 35 cm)
 ... max. 36 cm (slab thickness > 35 cm and up to 50 cm)

- A** Dokadek infill-beam shoe 18mm or 21mm
- B** Squared timber 200 x 40 mm
- C** Support timber (site-provided)
- D** Form-ply of 18mm or 21mm

Use with wall head

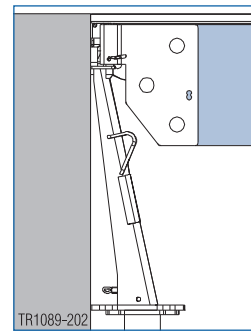

Assembly

- ▶ Cut the squared timber to length (± 2 mm).



NOTICE

Squared timber sized 200 x 40 mm with a min. timber quality of C24 (rough-cut).

Dokadek panel length [m]	Squared timber cut to length 'l' [m]
0.81	0.718
1.22	1.128
2.44	2.348

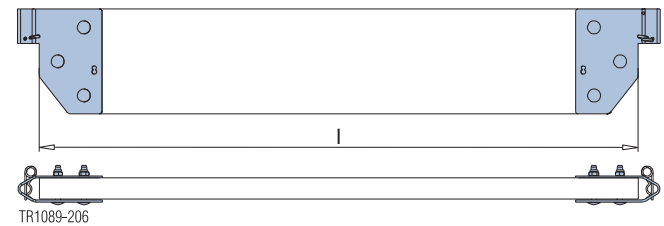

- ▶ Push the infill-beam shoe all the way onto the squared timber until this rests against the inside of the shoe, and mark the 3 holes to be drilled and the bevel to be cut.
- ▶ Remove the infill-beam shoe, drill holes with a diameter of 12 mm and bevel the ends of the squared timber.
- ▶ Push the infill-beam shoe back on to the squared timber and fix it using the enclosed cup square bolts M10x65mm and hexagon nuts M10 (self-locking).



Make sure that the bolts are tight and fitted correctly!

Infilling between 2 Dokadek forming-sections

Variant 1: Infill width 'a' = 17 - 61 cm

Max. infill width 'a' for slab thicknesses of up to 35 cm

Sheet thickness	Type of sheet	
	Doka formwork sheet 3-SO ¹⁾	Multi-ply sheet ²⁾
18 mm	—	53 cm
21 mm	38 cm	60 cm
27 mm	59 cm	—

Max. infill width 'a' for slab thicknesses of up to 50 cm

Sheet thickness	Type of sheet	
	Doka formwork sheet 3-SO ¹⁾	Multi-ply sheet ²⁾
18 mm	—	52 cm
21 mm	35 cm	58 cm
27 mm	52 cm	—

¹⁾ The computed values apply to the secondary (i.e. weaker) load-bearing direction, with the longitudinal direction of the sheet parallel to the edge of the floor-slab.

²⁾ Mean flexural modulus of elasticity where sheet moisture content is 10±2%: ≥ 5600 N/mm²
 Characteristic flexural strength where sheet moisture content is 10±2%: ≥ 19 N/mm²

Assembly:

- ▶ Hook the infill beams into the support heads (cheek plate at top).

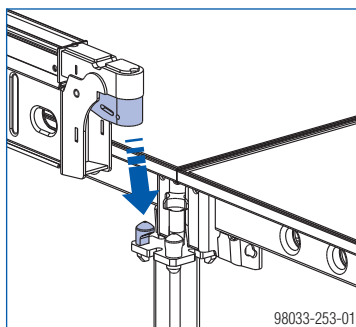

- ▶ Mount the fillers.

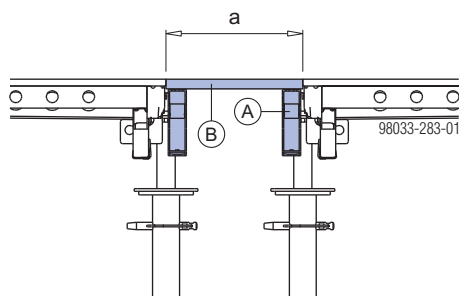

- A Dokadek infill beam
- B Formwork sheeting

Variant 2: Infill width 'a' = 55 - 270 cm

Infill width 'a' for slab thicknesses of up to 35 cm

Primary beam	Infill width 'a'	Recommended secondary beam
1.10 m	55 - 100 cm	2.90 m
1.80 m	90 - 170 cm	
2.90 m	145 - 270 cm	

Eurex 30:

- max. prop spacing 'b': 70 cm
- max. primary-beam spacing: 244 cm
- max. secondary-beam spacing: 45 cm (Do not exceed the max. support centres of the formwork sheets!)
- for infill gaps 'a' ≥ 80 cm: intermediate prop (with Supporting head H20) is required

Infill width 'a' for slab thicknesses of up to 50 cm

Primary beam	Infill width 'a'	Recommended secondary beam
1.10 m	55 - 100 cm	2.90 m
1.80 m	90 - 170 cm	
2.90 m	145 - 270 cm	

Eurex 30:

- max. prop spacing 'b': 47 cm
- max. primary-beam spacing: 244 cm
- max. secondary-beam spacing: 36 cm (Do not exceed the max. support centres of the formwork sheets!)
- for infill gaps 'a' ≥ 72 cm: intermediate prop (with Supporting head H20) is required

Assembly:

- ▶ Hook the infill beams into the support heads (cheek plate at top).

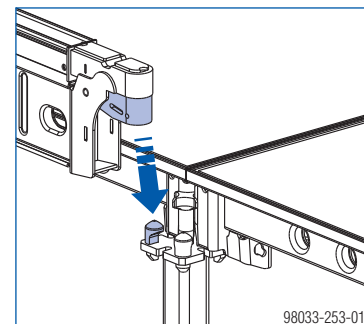

- ▶ Hook the suspension clamps into the infill beams as close to the floor props as possible.

Number of suspension clamps needed:

- next to every floor prop in the longitudinal direction
- next to every other floor prop in the transverse direction

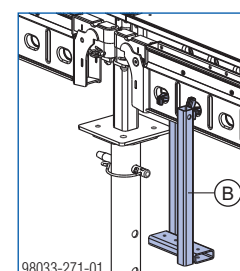

► Mount the fillers.

Practical examples

Practical example: Infill width 'a' ≤ 80 cm

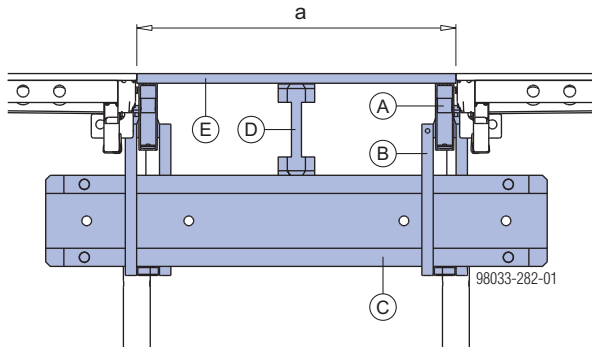

Practical example: Infill width 'a' > 80 cm (with intermediate prop)

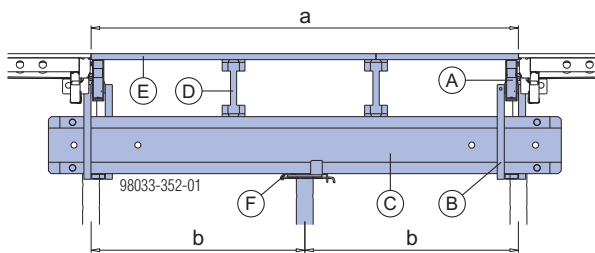

L-shaped infill zone

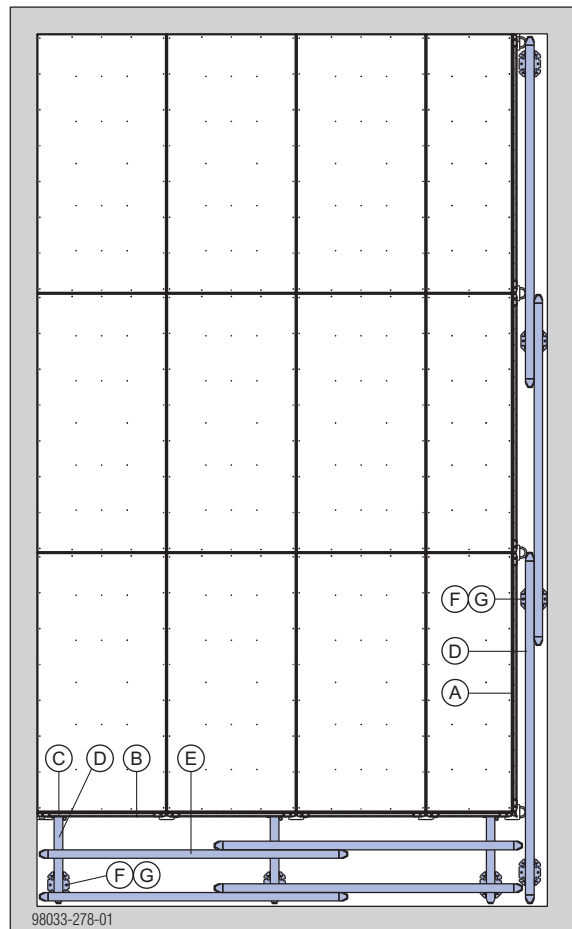

- A Dokadek infill beam
- B Dokadek suspension clamp H20
- C Doka beam H20 as primary beam
- D Doka beam H20 as secondary beam
- E Formwork sheeting
- F Intermediate prop with Supporting head H20



Place a beam (or double beam) wherever there is to be a joint between the panels.

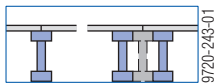

- A Dokadek infill beam 2.44m
- B Dokadek infill beam 1.22m or 0.81m
- C Dokadek suspension clamp H20
- D Doka beam H20 used as primary beam
- E Doka beam H20 used as secondary beam
- F Doka floor prop Eurex 30 top + Removable folding tripod
- G Lowering head H20



NOTICE

Put up the intermediate props so that they force-fit. It is not allowed to make some props higher than others!

T-shaped infill zone

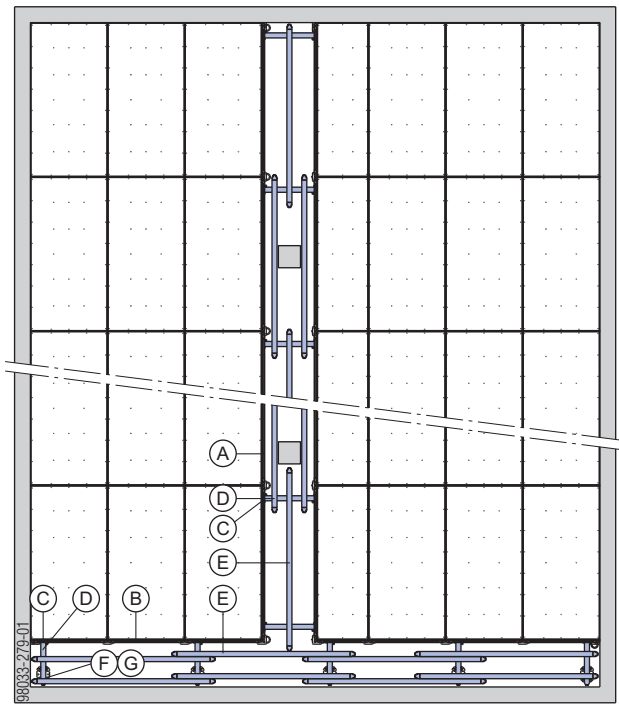

Dokadek infill-beam shoes

at T-wall junctions

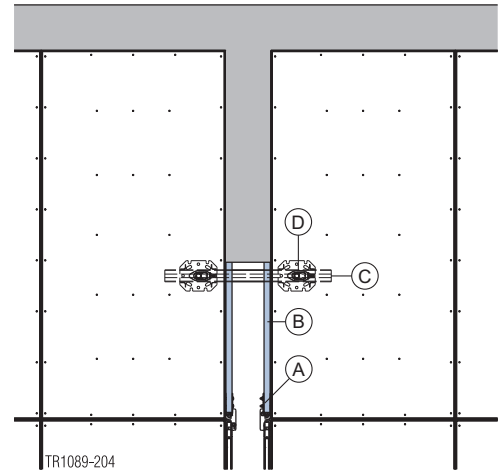

- A** Dokadek infill-beam shoe 18mm or 21mm
- B** Squared timber 200 x 40 mm
- C** Doka beam H20
- D** Doka floor prop Eurex 30 top + Removable folding tripod top + Lowering head H20

Adapting to difficult layout shapes

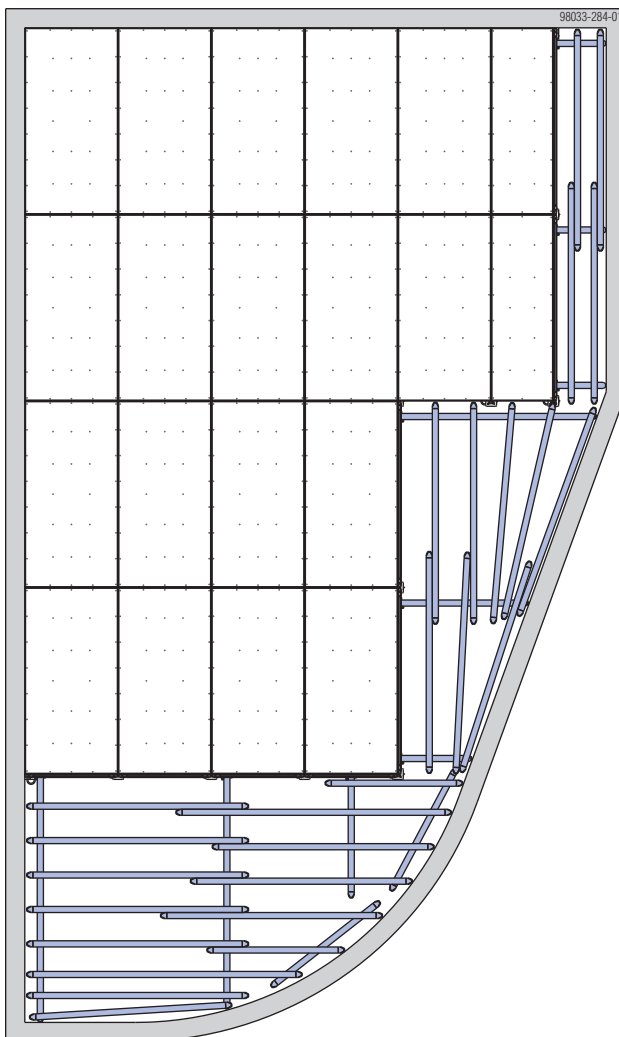

Symbolic representation

with Dokadek custom panels

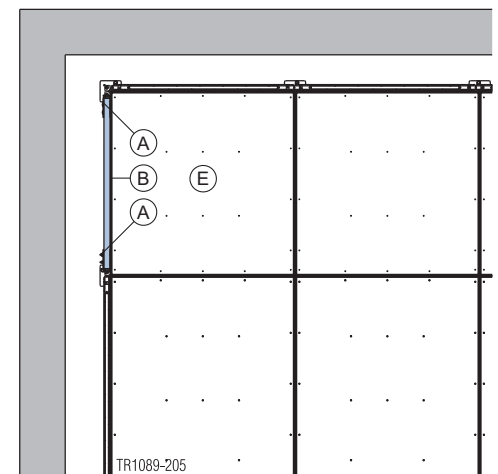

- A** Dokadek infill-beam shoe 18mm or 21mm
- B** Squared timber 200 x 40 mm
- E** Dokadek custom panel

Infill zones around columns

using Dokadek infill beams and Doka beams H20

- ▶ Hook 2 Infill beams 1.22m or 0.81m into the support heads in the transverse direction (cheek plate at top).
- ▶ Hook 4 suspension clamps into the infill beams as close to the floor props as possible.

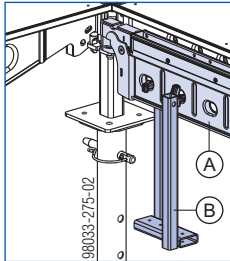

- ▶ Fit 2 Doka beams H20 into the suspension clamps, to serve as primary beams.
- ▶ E.g. with 1.22 m wide panels: place Doka beams H20 (e.g. Dokadek system beams H20 eco P 1.10m for a panel width of 1.22 m) onto the primary beams, in the transverse direction.



Place a beam (or double beam) wherever there is to be a joint between the panels.

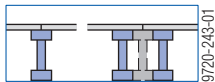

NOTICE

Put up the intermediate props so that they force-fit. It is not allowed to make some props higher than others!

Practical examples - Column located inside panel-field (variant 1)

Slab thickness ≤ 35 cm

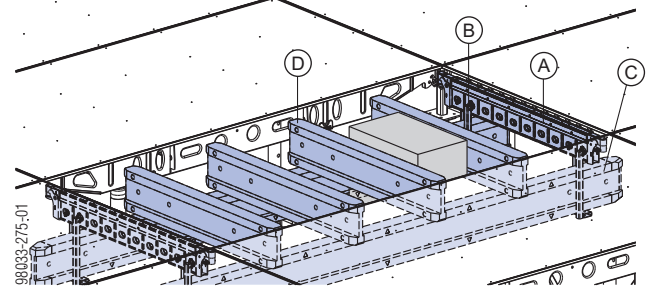

Slab thickness > 35 - 50 cm

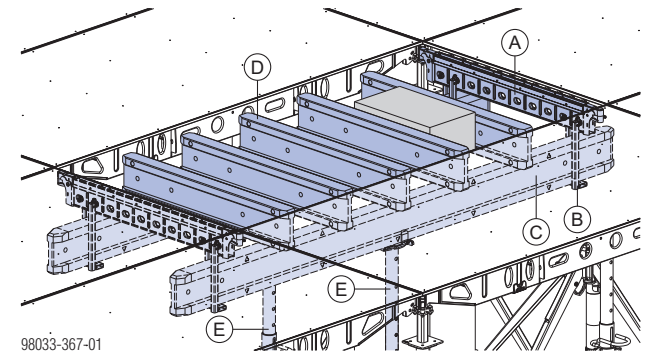

Slab thickness	Max. secondary-beam spacing	N° of extra shores per primary beam
≤ 35 cm	50 cm ¹⁾	—
> 35 - 50 cm	42 cm ¹⁾	1 (in mid-span)

¹⁾ Do not exceed the max. support centres of the formwork sheets!

A Dokadek infill beam 1.22m or 0.81m

B Dokadek suspension clamp H20

C Doka beam H20 2.90m as primary beam

D Doka beam H20 as secondary beam (e.g. Dokadek system beam H20 eco P 1.10m for a panel width of 1.22 m)

E Extra shore (in mid-span):

- Doka floor prop Eurex 30 top
- Supporting head H20 DF

Practical examples - Column located inside panel-field (variant 2)



If necessary, the infill beams and Doka beams H20 can also be arranged the other way round, i.e. the Infill beams 2.44m on which the suspension clamps are mounted are fixed in the longitudinal direction.

Slab thickness ≤ 35 cm

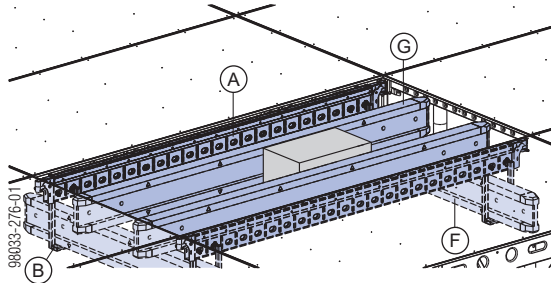

Slab thickness > 35 - 50 cm

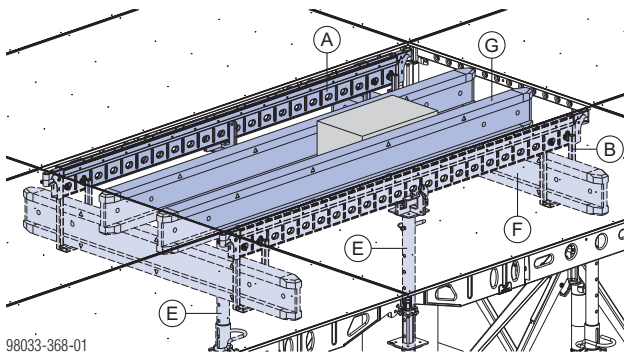

Slab thickness	Max. secondary-beam spacing	N° of extra shores per infill beam
≤ 35 cm	50 cm ¹⁾	—
> 35 - 50 cm	42 cm ¹⁾	1 (in mid-span)

¹⁾ Do not exceed the max. support centres of the formwork sheets!

- A** Dokadek infill beam 2.44m
- B** Dokadek suspension clamp H20
- E** Extra shore (in mid-span):
 - Doka floor prop Eurex 30 top
 - Dokadek edge head + Spring locked connecting pin 16mm
- F** Doka beam H20 as primary beam (e.g. Doka beam H20 1.80m for a panel width of 1.22 m)
- G** Doka beam H20 2.45m as secondary beam

Practical examples - Column is exactly beneath the panel joint

Slab thickness ≤ 35 cm

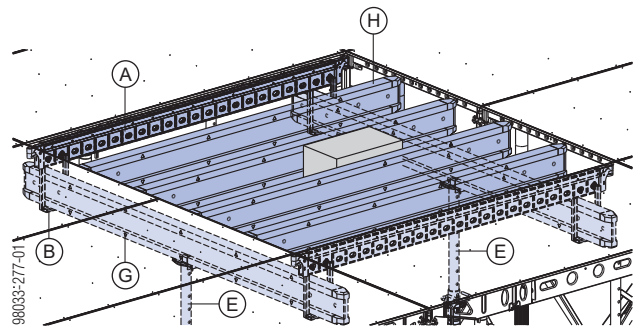

Slab thickness > 35 - 50 cm

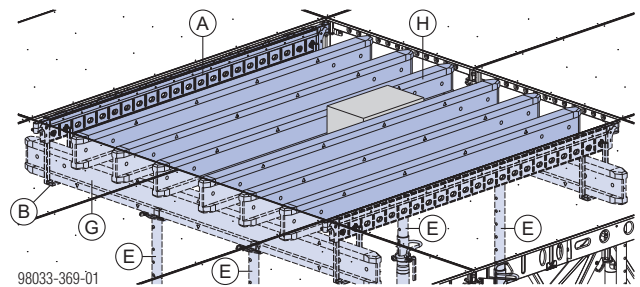

Slab thickness	Max. secondary-beam spacing	N° of extra shores per primary beam
≤ 35 cm	50 cm ¹⁾	1 (in mid-span)
> 35 - 50 cm	42 cm ¹⁾	2 (at the one-third points)

¹⁾ Do not exceed the max. support centres of the formwork sheets!

- A** Dokadek infill beam 2.44m
- B** Dokadek suspension clamp H20
- E** Extra shore:
 - Doka floor prop Eurex 30 top
 - Supporting head H20 DF
- G** Doka beam H20 as primary beam (e.g. Doka beam H20 2.90m for a panel width of 1.22 m)
- H** Doka beam H20 2.45m as secondary beam

with Dokadek panel 1.22x1.22m or 0.81x1.22m, Dokadek infill beam and Doka beam H20

Note:

- The Dokadek support heads (**B**) have to be levelled approx. 5 cm lower than the other heads to avoid off-sets.
- Set up the surrounding Dokadek panels 2.44m first, then engage the Dokadek panels 1.22m and swing them up into position.
- ▶ Engage the Dokadek panel 1.22x1.22m or 0.81x1.22m and swing it up into position in the longitudinal direction.
- ▶ Hook two infill beams 1.22m or 0.81m into the support heads in the transverse direction (cheek plate at top).
- ▶ Hook 4 suspension clamps into the infill beams as close to the floor props as possible.

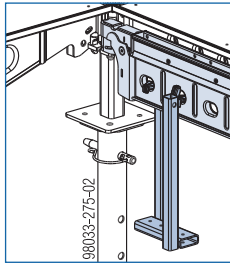

- ▶ Fit 2 Doka beams H20 into the suspension clamps, to serve as primary beams.
- ▶ Place Doka beams H20 onto these primary beams, in the transverse direction.



Up to a room height of 3.74 m, the suspension tool can be used for setting up and stripping out the panels from floor level.

Practical examples - Column located inside panel-field

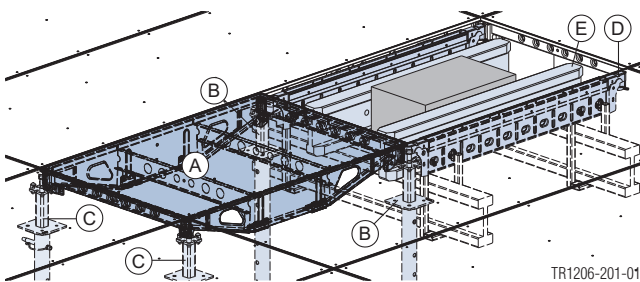

Dokadek panel	Slab thickness	N° of extra shores per primary beam
1.22x1.22m	≤ 35 cm	—
0.81x1.22m	≤ 50 cm	—

- A** Dokadek panel 1,22x1,22m or 0,81x1,22m
- B** Dokadek support head + Doka floor prop Eurex 30 top (in the middle of the closure)
- C** Dokadek support head + Doka floor prop Eurex 30 top (at the inter-panel joint)
- D** Dokadek infill beam 1.22m
- E** Doka beam H20 used as secondary beam

using Dokadek infill beams

- ▶ Hook 2 Infill beams 2.44m into the support heads in the longitudinal direction (cheek plate and locking mechanism at bottom).
- ▶ Place Infill beams 1.22m or 0.81m on the Infill beams 2.44m in the transverse direction (cheek plate at bottom, locking mechanism at top).



Position (**A**) of the locking mechanism of the transverse Infill beam 1.22m or 0.81m:

- at all 4 corners, in the recesses (**B**) on the Infill beams 2.44m
- between these, in the profile slots (**C**) on the Infill beams 2.44m

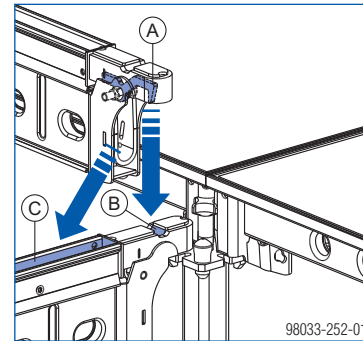

Be sure to place 2 infill beams wherever there is to be a joint between the panels.

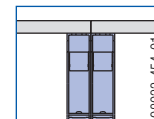

NOTICE

Put up the intermediate props so that they force-fit. It is not allowed to make some props higher than others!

Practical examples - Column located inside panel-field (variant 1)

Slab thickness ≤ 35 cm

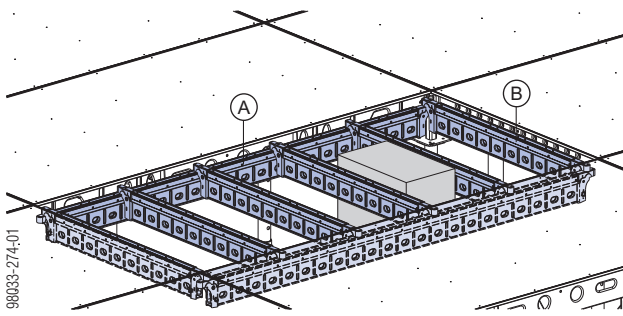

Slab thickness > 35 - 50 cm

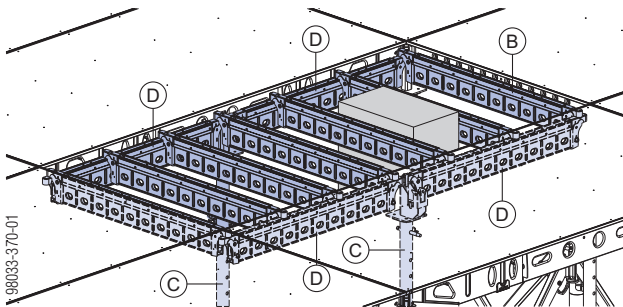

Slab thickness	Max. secondary-beam spacing	N° of extra shores
≤ 35 cm	50 cm ¹⁾	—
> 35 - 50 cm	42 cm ¹⁾	1

¹⁾ Do not exceed the max. support centres of the formwork sheets!

- A** Dokadek infill beam 2.44m
- B** Dokadek infill beam 1.22m or 0.81m
- C** Extra shore:
 - Doka floor prop Eurex 30 top
 - Dokadek cross head + Spring locked connecting pin 16mm
- D** Dokadek infill beams 1.22m (4 in all)

Practical examples - Column located inside panel-field (variant 2)



If necessary, the infill beams can also be arranged the other way round, i.e. the Infill beams 2.44m are laid onto the underlying Infill beams 1.22m or 0.81m.

Slab thickness ≤ 35 cm

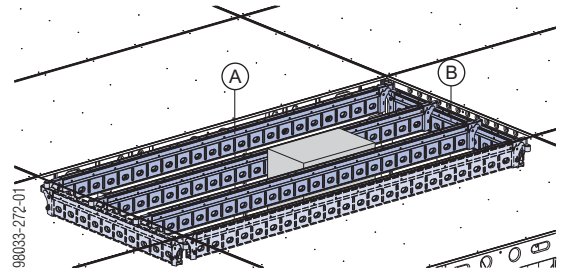

Slab thickness > 35 - 50 cm

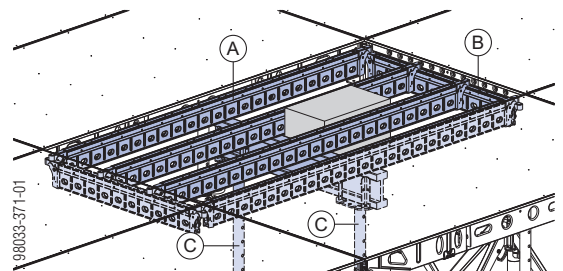

Slab thickness	Max. secondary-beam spacing	N° of extra shores on infill beams
≤ 35 cm	50 cm ¹⁾	—
> 35 - 50 cm	42 cm ¹⁾	1 (in mid-span)

¹⁾ Do not exceed the max. support centres of the formwork sheets!

- A** Dokadek infill beam 2.44m
- B** Dokadek infill beam 1.22m or 0.81m
- C** Extra shore for Dokadek infill beam 2.44m (pos. A):
 - Doka floor prop Eurex 30 top
 - Removable folding tripod top
 - Lowering head / 4-way head H20
 - Doka beam H20 1.25m when using Dokadek panels 1.22x2.44m



NOTICE

The extra prop must only be used for Dokadek infill beams 2.44m, and not for Dokadek panels.

Practical examples - Column is exactly beneath the panel joint

Slab thickness ≤ 35 cm

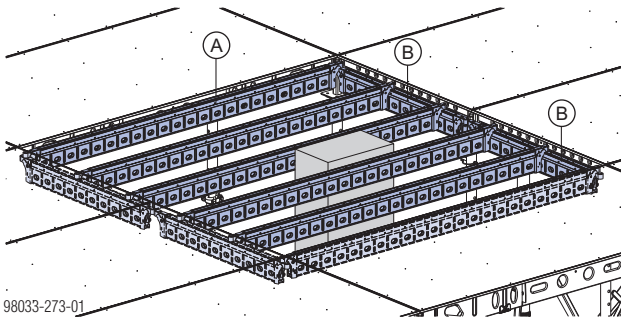

Slab thickness > 35 - 50 cm

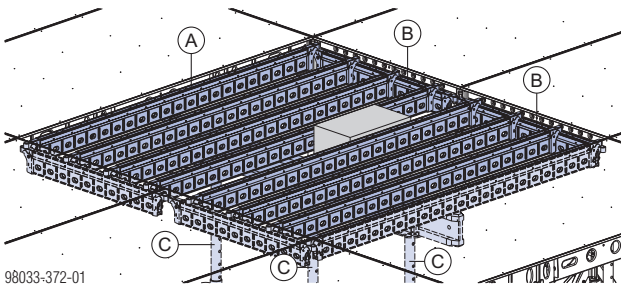

Slab thickness	Max. secondary-beam spacing	N° of extra shores on infill beams
≤ 35 cm	50 cm ¹⁾	—
> 35 - 50 cm	42 cm ¹⁾	1

¹⁾ Do not exceed the max. support centres of the formwork sheets!

- A** Dokadek infill beam 2.44m
- B** Dokadek infill beam 1.22m or 0.81m
- C** Extra shore for Dokadek infill beam 2.44m (pos. A):
 - Doka floor prop Eurex 30 top
 - Removable folding tripod top
 - Lowering head / 4-way head H20
 - Intermediate prop with Supporting head H20 DF
 - Doka beam H20 2.45m when using Dokadek panels 1.22x2.44m



NOTICE

The extra prop must only be used for Dokadek infill beams 2.44m, and not for Dokadek panels.

FreeFalcon



A fall arrester such as the FreeFalcon provides a mobile anchorage point for the safety harness.



WARNING

Risk of falling at open edges!

- ▶ The crew must use personal fall-arrest systems (e.g. safety harnesses) until all fall protection has been installed.
- ▶ Suitable attachment points must be defined by an approved person appointed by the contractor.



User instruction prior to use of the FreeFalcon is mandatory. Follow the directions in the 'FreeFalcon' Operating Instructions!

Floor formwork around edges

with Lashing strap 5.00m and Doka express anchor 16x125mm



Follow the directions in the 'Doka express anchor 16x125mm' and 'Lashing strap 5.00m' User Information booklets.

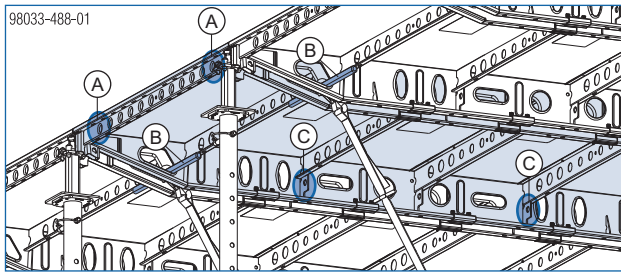

Always perform a static check if other-make heavy-duty dowels are used to fabricate anchorages in the floor slab.
Follow the manufacturers' applicable fitting instructions.

Practical examples

Permissible tie-back force [kN]

A	Anchorage point in frame profile for longitudinal and transverse tie-backs	5 kN
B	Tie rod 20.0 in inter-panel joint for longitudinal tie-backs	5 kN
C	Anchorage point at the one-third point for longitudinal and transverse tie-backs	2.5 kN



WARNING

- ▶ Do NOT exceed the permitted tie-back angle and tie-back force, so as to prevent damage to the Dokadek panel and to ensure that all forces from horizontal loads can be transferred in conformity with EN 12812.
- ▶ Use bracing to transfer horizontal forces. These forces can also be transferred into existing structural members such as concrete columns or walls.

Tie-back in transverse direction

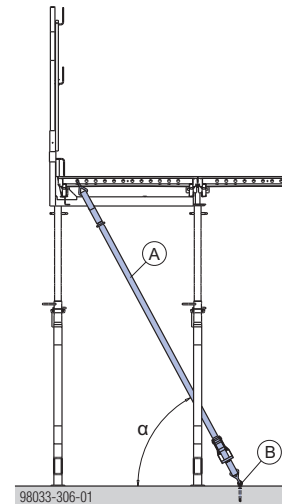

NOTICE

- ▶ Only attach the Lashing strap 5.00m to the points shown above and tension it in the required direction of the profile.
- ▶ It is forbidden to fix tie-backs to the inside cross profiles!
- ▶ Prepare an anchorage point in the ground with the Doka express anchor.
- ▶ Attach the lashing strap and tighten it.

Tie-back in longitudinal direction

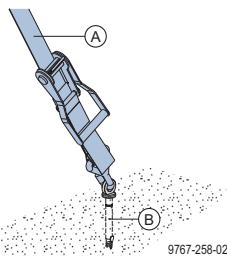
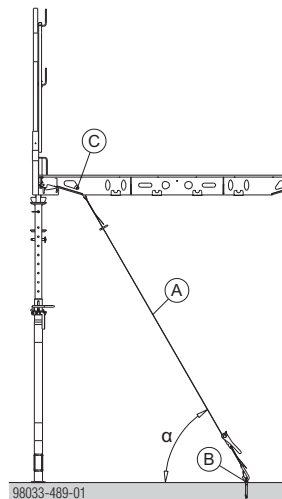

- A Lashing strap 5.00m
- B Doka express anchor 16x125mm

α ... Bracing angle approx. 60°

- A Lashing strap 5.00m
- B Doka express anchor 16x125mm
- C Tie rod 20.0

The **Doka express anchor** can be re-used many times over.

Permissible load in young (new) concrete and in cured C20/25 concrete with a characteristic cube compressive strength of $f_{ck,cube} \geq 14 \text{ N/mm}^2$:
 $F_{perm.} = 5.0 \text{ kN}$ ($R_d = 7.5 \text{ kN}$)

Fall protection on the formwork

CAUTION

- ▶ The handrail-post shoe short and handrail-post shoe long may only be used in combination with the Handrail post XP 1.20m.
- ▶ The Handrail-post shoe short 1.20m may only be used in combination with the Handrail post XP 1.20m or 1.80m.
- ▶ Use of Handrail-post shoe long 1.20m with Handrail post XP 1.80m not permitted.

NOTICE

- Ideally, fall protection should be mounted from below (e.g. using a Wheel-around scaffold DF).
- When mounting/dismounting edge protection from above, the crew must use a personal fall-arrest system (e.g. safety harness).
- Suitable attachment points must be defined by an approved person appointed by the contractor.



Follow the directions in the 'Xsafe edge protection XP' User Information booklet.

Guardrail system with transfer of concreting loads

The Dokadek handrail-post shoes are fixed to defined positions on the previously-mounted Dokadek panel. They are used for holding Handrail posts XP 1.20m (see section [Slab stop-ends](#)).

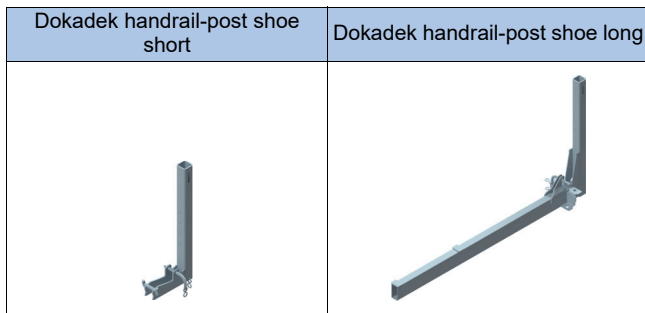

Possible fixing points for the handrail-post shoes

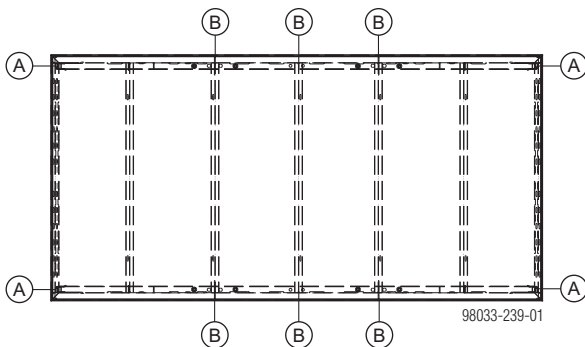

- A Dokadek handrail-post shoe short
- B Dokadek handrail-post shoe long

Permissible influence width [cm] of the handrail-post shoes for slab thicknesses of up to 32 cm (without additional precautions)

Peak velocity pressure q [kN/m ²]	Safety barrier			
	Guardrail board 15 cm ¹⁾	Guardrail board 20 cm ¹⁾	Scaffold tube 48.3mm	Protective grating XP 2.70x1.20m
	With concrete load			
0.2	137	137	137	137
	Without concrete load			
0.2	259	259	259	259
0.6	259	137	259	259
1.1	137	—	259	259
1.3	—	—	259	244

¹⁾ Minimum thickness 3 cm for influence width greater than 137 cm.

Permissible influence width [cm] of the handrail-post shoes for slab thicknesses of up to 50 cm (with additional precautions)

Peak velocity pressure q [kN/m ²]	Safety barrier		
	Guardrail board 15 cm ¹⁾²⁾	Guardrail board 20 cm ¹⁾²⁾	Protective grating XP 2.70x1.20m
	With concrete load		
0.2	137 ²⁾	137	137
	Without concrete load		
0.2	259 ²⁾	259	259
0.6	259 ²⁾	137	259
1.1	137 ²⁾	—	259
1.3	—	—	244

¹⁾ Minimum thickness 3 cm for influence width greater than 137 cm.

²⁾ Guardrail boards 15 cm are only permitted up to a slab thickness of 45 cm.



- The span of the handrail posts is roughly equal to the influence width if
 - they are evenly spaced,
 - the guardrail boards are either continuous or are jointed at the handrail posts, and
 - there are no cantilevering projections.
- The wind conditions likely to be encountered in Europe, in accordance with EN 13374, are largely recognised by the peak velocity pressure $q=0.6 \text{ kN/m}^2$ (highlighted grey in the tables).



NOTICE

For slab thicknesses > 30 cm, raise the Protective grating XP into the position shown here, so as to obtain the required railing height after pouring.

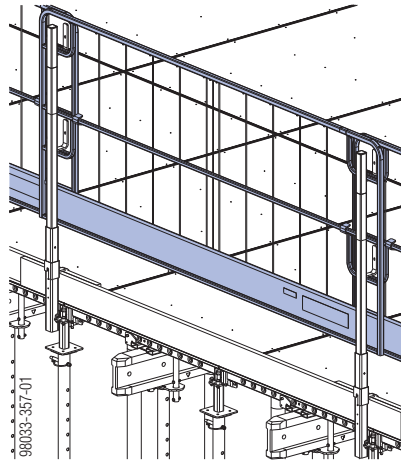

Attaching a 'Handrail-post shoe - short'

- ▶ Working from below, push the handrail-post shoe short onto the longitudinal profile of the Dokadek panel and fix it with bolts (these are included in the scope of supply of the handrail-post shoe short).

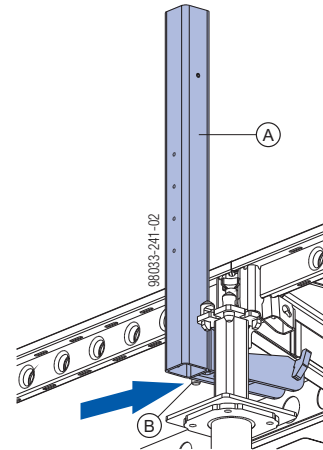

Make sure that the handrail-post shoe short (A) and the bolt (vertical!) (B) are in the correct position!

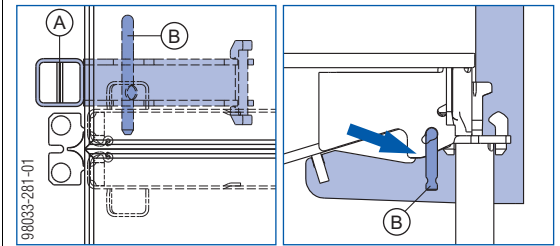

Animation: <https://player.vimeo.com/video/263298687>

- ▶ Push on the Handrail post XP 1.20m until it locks ('Easy-Click' function).
- ▶ Mount the sideguards.

Practical example with Protective grating XP

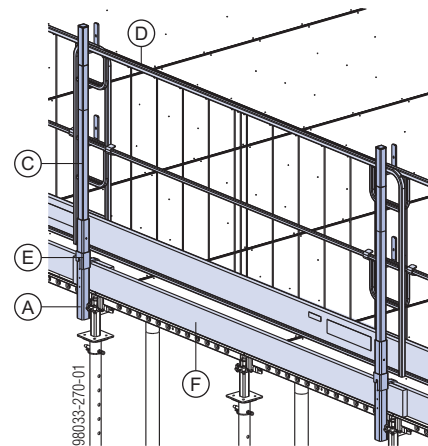

- A Dokadek handrail-post shoe short
- B Pin
- C Handrail post XP 1.20m
- D Protective grating XP 2.70x1.20m
- E Toeboard holder XP 0.60m
- F Toeboard

Attaching a 'Handrail-post shoe - long'

- ▶ Working from below, push the handrail-post shoe long onto the longitudinal profile of the Dokadek panel, in the transverse direction, and fix it to the cross profile with pins (these are included in the scope of supply of the handrail-post shoe long).

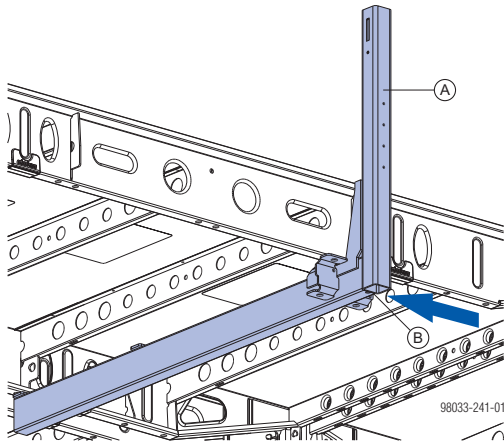

Make sure that the pin (B) is in the vertical position!

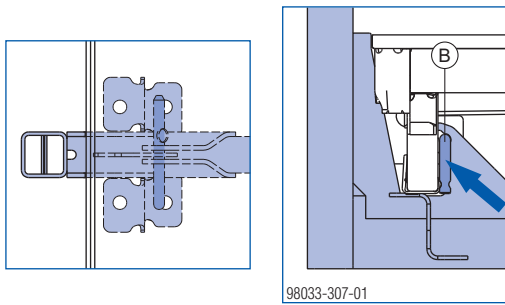

Animation: <https://player.vimeo.com/video/263298834>

- ▶ Push on the Handrail post XP 1.20m until it locks ('Easy-Click' function).
- ▶ Mount the sideguards.

Practical example with guardrail boards

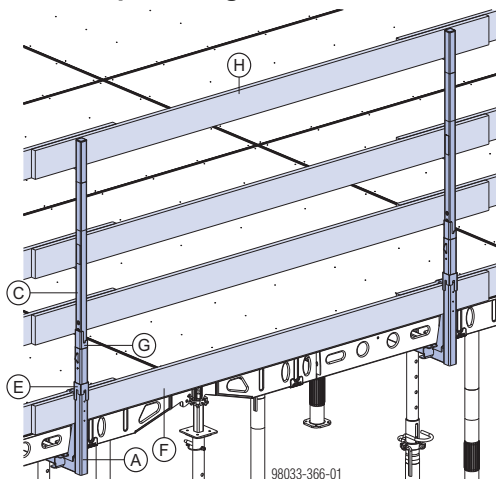

A Dokadek handrail-post shoe long

B Pin

C Handrail post XP 1.20m

E Toeboard holder XP 0.60m

F Toeboard

G Toeboard holder XP 1.20m

H Guardrail boards

Fall protection at corners



NOTICE

- In corner zones, the Protective gratings XP must be attached to the Handrail posts XP with cable ties or binding wire (see the blue markings in the examples illustrated here). It is not permitted to use the Velcro® fastener 30x380mm.
- On the broadside of the panel, the first grating to be placed (starting from the corner) must always be a Protective grating 2.00m. After this, Protective gratings 2.70m can be used.
- For slab thicknesses > 32 cm, an extra Toeboard holder XP must be mounted on the corner Handrail post XP.

Close-up: Means of attachment

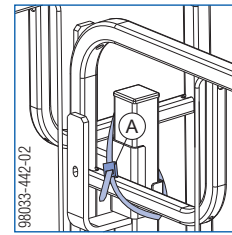

Close-up: extra Toeboard holder XP 1.20m

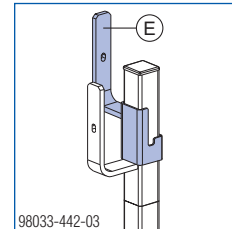

Practical example for slab thickness ≤ 32 cm

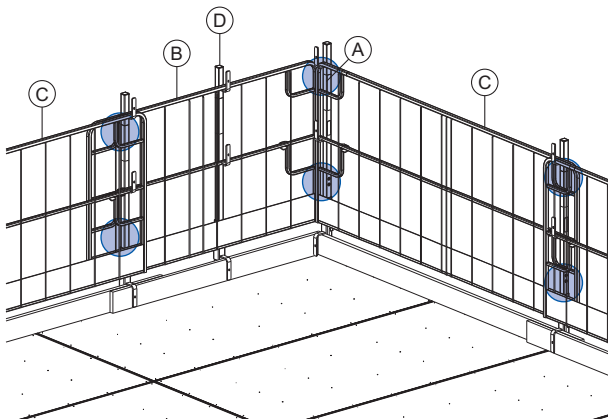

98033-441-01

- A Attached with cable tie or binding wire
- B Protective grating XP 2.00x1.20m
- C Protective grating XP 2.70x1.20m
- D Handrail post XP 1.20m
- E Toeboard holder XP 1.20m

Close-up: Means of attachment

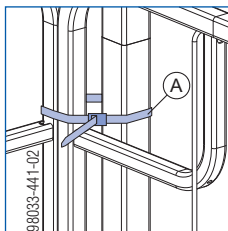

Practical example for slab thickness > 32 cm

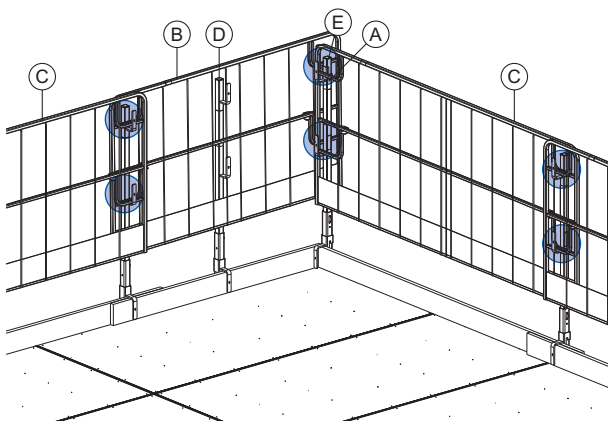

98033-442-01

Guardrail system without transfer of concreting loads

The Dokadek handrail-post shoes 1.20m are fixed to defined positions on the previously-mounted Dokadek panel. They are used for holding Handrail posts XP 1.20m or 1.80m.

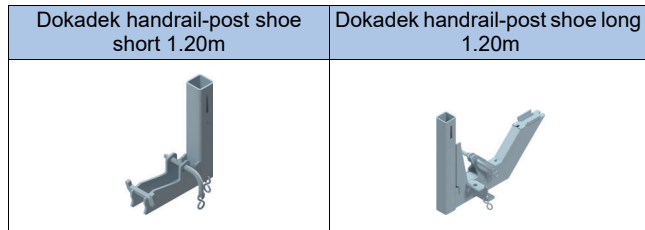

Possible fixing points for the handrail-post shoes

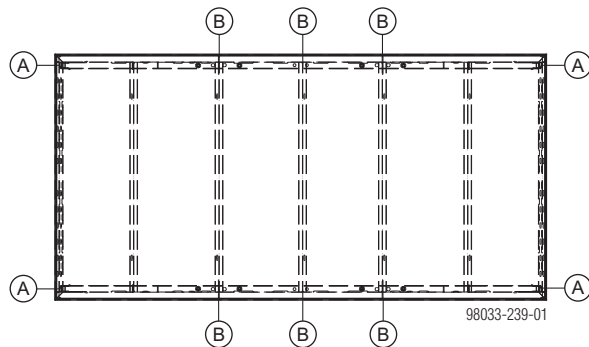

A Dokadek handrail-post shoe short 1.20m

B Dokadek handrail-post shoe long 1.20m



Follow the directions in the 'Xsafe edge protection XP' User Information booklet!



CAUTION

► Allowance for a DIN 4420 walkway of at least 60 cm in width has to be made when using the Handrail-post shoes short and Handrail-post shoes long 1.20m with a Handrail post XP 1.20m.

Consequently, use of the Handrail-post shoes short 1.20m and a Handrail post XP 1.20m is not permitted if there are projecting panels at the edge of the structure.

Note:

The information stated here is compliant with the German DIN standards and the rules set out by the German Employers Liability Insurance Association for the Construction Industry and consequently, they are particularly applicable within Germany. However, this ruling can be used as a recommendation in other countries, unless other, stricter national regulations apply. It is the responsibility of the national organisation in the country in question to establish whether this is the case.

Permissible influence width [cm] of the handrail-post shoes with Handrail posts XP 1.20m

Peak velocity pressure q [kN/m ²]	Safety barrier			
	Guardrail board 15 cm ¹⁾	Guardrail board 20 cm ¹⁾	Scaffold tube 48.3mm	Protective grating XP 2.70x1.20m
	Without concrete load			
0.2	259	259	259	259
0.6	259	137	259	259
1.1	137	—	259	259
1.3	—	—	259	244

¹⁾ Minimum thickness 3 cm for influence width greater than 137 cm.

Permissible influence width [cm] of the Handrail-post shoe short 1.20m with Handrail post XP 1.80 m

Peak velocity pressure q [kN/m ²]	Safety barrier			
	Guardrail board 15 cm ¹⁾	Guardrail board 20 cm ¹⁾	Scaffold tube 48.3mm	Protective grating XP 2.70x1.20m + 2.70x0.60m
	Without concrete load			
0.2	259	244	259	259
0.6	259	137	259	259
1.1	122	61	259	259
1.3	61	61	259	244

¹⁾ Minimum thickness 3 cm for influence width greater than 137 cm.



- The span of the handrail posts is roughly equal to the influence width if
 - they are evenly spaced,
 - the guardrail boards are either continuous or are jointed at the handrail posts, and
 - there are no cantilevering projections.
- The wind conditions likely to be encountered in Europe, in accordance with EN 13374, are largely recognised by the peak velocity pressure $q=0.6 \text{ kN/m}^2$ (highlighted grey in the tables).

Secure the Dokadek handrail-post shoe short 1.20m

- ▶ Working from below, push the handrail-post shoe short 1.20m onto the longitudinal profile of the Dokadek panel and fix it with bolts (these are included in the scope of supply of the handrail-post shoe short).

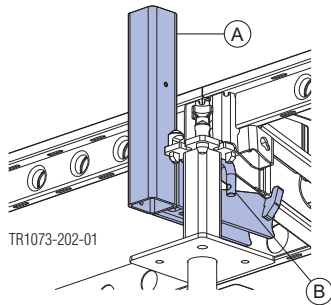

Make sure that the handrail-post shoe short (A) and the bolt (vertical!) (B) are in the correct position!

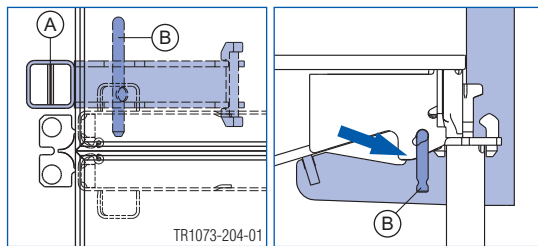

Animation: <https://player.vimeo.com/video/263298915>

- ▶ Push on the Handrail post XP 1.20m until it locks ('Easy-Click' function).
- ▶ Mount the sideguards.

Practical example with Protective grating XP

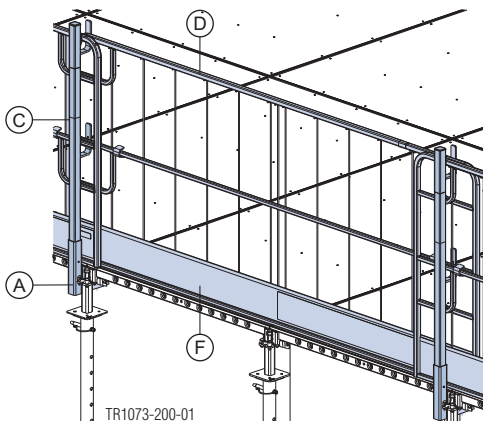

- A Dokadek handrail-post shoe short 1.20m
- B Pin
- C Handrail post XP 1.20m
- D Protective grating XP 2.70x1.20m
- F Toeboard

Secure the Dokadek handrail-post shoe long 1.20m

- ▶ Working from below, push the handrail-post shoe long 1.20m onto the longitudinal profile of the Dokadek panel, in the transverse direction, and fix it to the cross profile with pins (these are included in the scope of supply of the handrail-post shoe long).

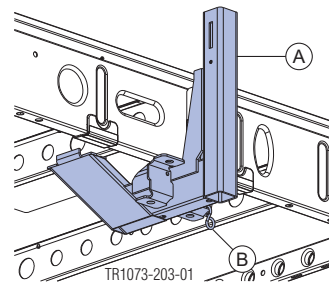

Make sure that the pin (B) is in the vertical position!

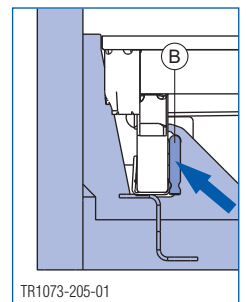
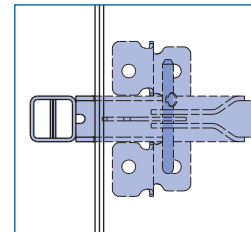

Animation: <https://player.vimeo.com/video/263299062>

- ▶ Push on the Handrail post XP 1.20m until it locks ('Easy-Click' function).
- ▶ Mount the sideguards.

Practical example with guardrail boards

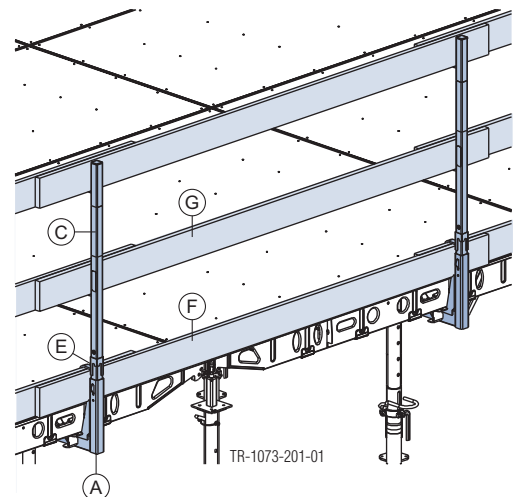

- A Dokadek handrail-post shoe long 1.20m
- B Pin
- C Handrail post XP 1.20m
- E Toeboard holder XP 1.20m
- F Toeboard
- G Guardrail boards

Fall protection at corners



NOTICE

- In corner zones, the Protective gratings XP must be attached to the Handrail posts XP with cable ties or binding wire (see the blue markings in the examples illustrated here). It is not permitted to use the Velcro® fastener 30x380mm.
- On the broadside of the panel, the first grating to be placed (starting from the corner) must always be a Protective grating XP 2.00m. After this, Protective gratings XP 2.70m can be used.

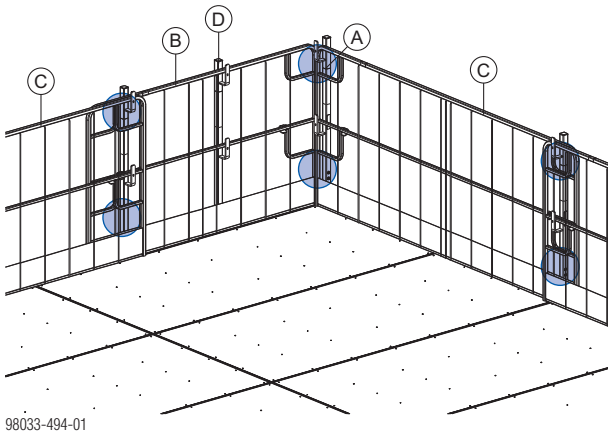

Close-up showing how fastened:

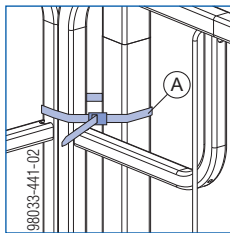

- A** Attached with cable tie or binding wire
- B** Protective grating XP 2.00x1.20m
- C** Protective grating XP 2.70x1.20m
- D** Handrail post XP 1.20m

Fall protection on the structure

Xsafe edge protection XP

- Attached with screw-on shoe, railing clamp, hand-rail-post shoe or Step bracket XP
- Protective grating XP, guardrail boards or scaffold tubes can be used as the safety barrier

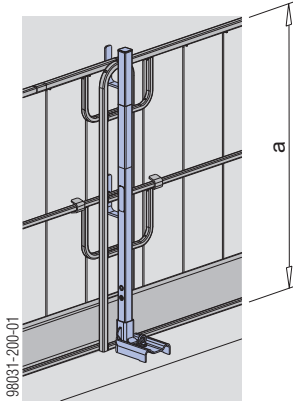

a ... > 1.00 m



Follow the directions in the 'Xsafe edge protection XP' User Information booklet.

Xsafe edge protection Z

- Attachment by integral screw-on shoe
- Protective barrier Z can be used as the safety barrier

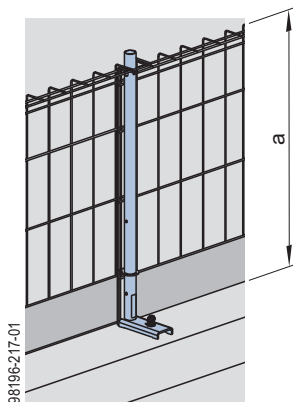

a ... > 1.17 m



Follow the directions in the 'Xsafe edge protection Z' User Information booklet.

Handrail clamp S

- Attached with integral clamp
- Guard-rail boards or scaffold tubes can be used as the safety barrier

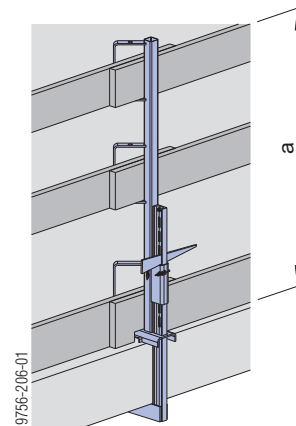

a ... > 1.00 m



Follow the directions in the "Handrail clamp S" User information!

Handrail post 1.10m

- Fixed in a Screw sleeve 20.0 or Attachable sleeve 24mm
- Guard-rail boards or scaffold tubes can be used as the safety barrier

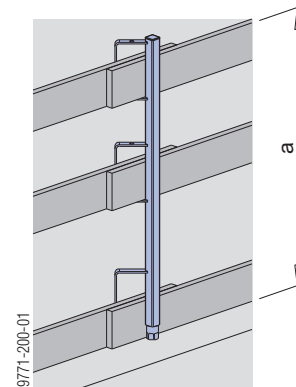

a ... > 1.00 m



Follow the directions in the 'Handrail post 1.10m' User Information!

Doka floor end-shutter clamp

- Slab stop-ends and fall-arrest barriers in one system

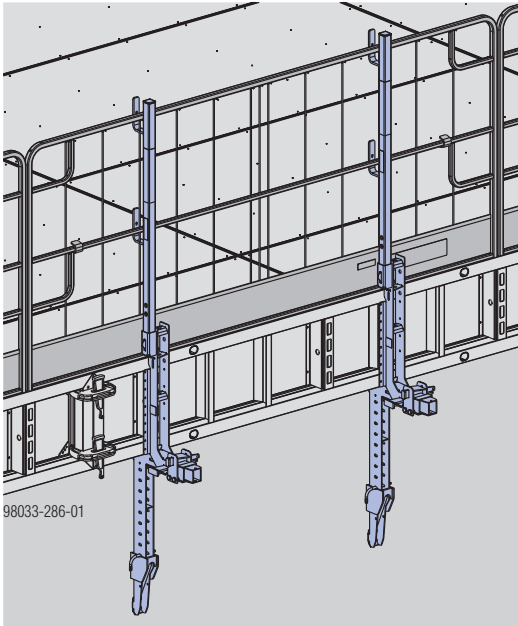

Follow the directions in the "Doka floor end-shutter clamp" User Information booklet!

Floor end-shutter profile XP

- Slab stop-ends and safety barriers in one system

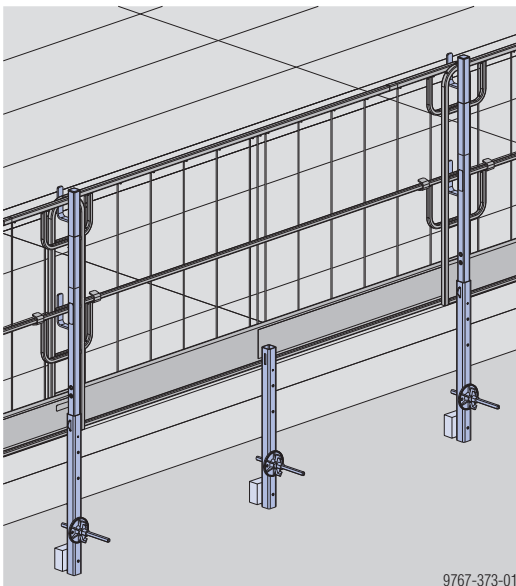

Follow the directions in the 'Xsafe edge protection XP' User Information booklet.

Slab stop-ends

Permissible influence width of the Dokadek handrail-post shoes with slab stop-ends: 137 cm

in the longitudinal direction

Practical example for slab thickness ≤ 32 cm

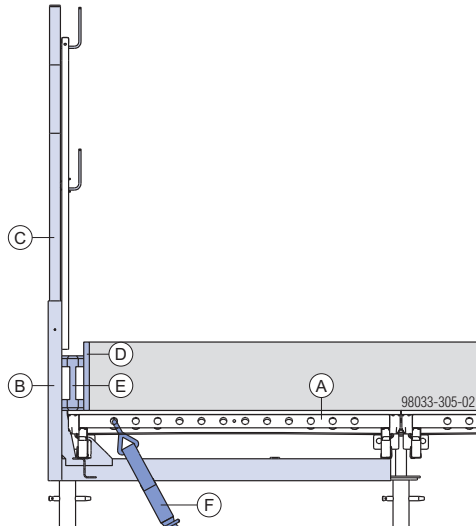

Practical example for slab thickness > 32 cm

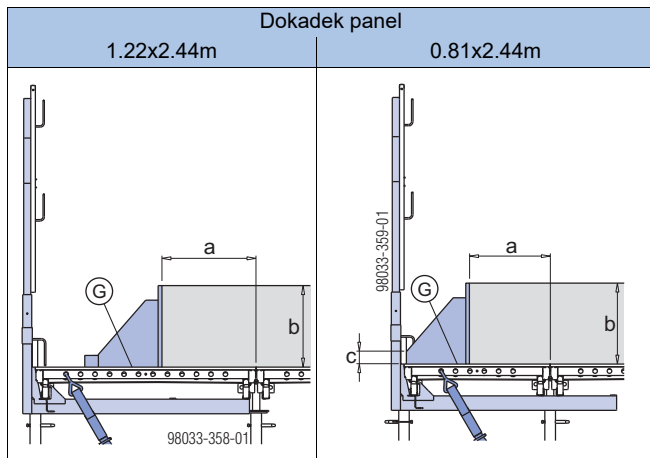

b ... max. 50 cm
c ... max. 5 cm

Dokadek panel	Max. projecting concrete cover on Dokadek panel a [cm]	Max. slab thickness b [cm]
1.22x2.44m	52	50
0.81x2.44m	All remainder of panel	45

in the transverse direction

Practical example for slab thickness ≤ 32 cm

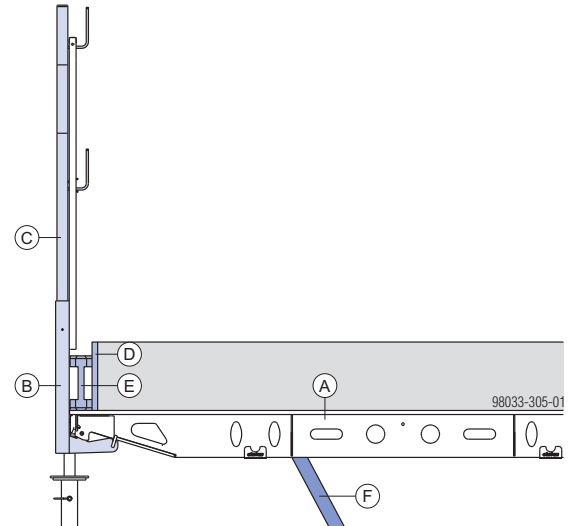

Practical example for slab thickness > 32 cm

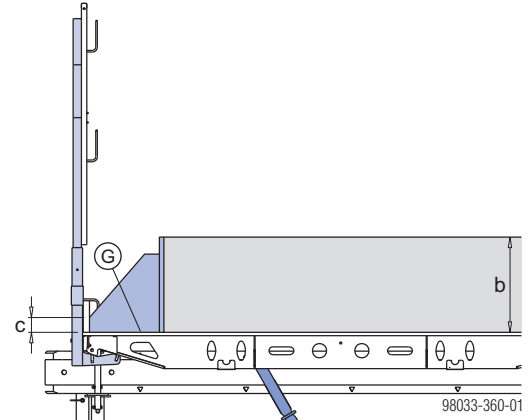

b ... max. 50 cm
c ... max. 5 cm

- A** Dokadek panel
- B** Dokadek 'handrail-post shoe long' or 'handrail-post shoe short'
- C** Handrail post XP 1.20m
- D** Formwork sheeting
- E** Doka beam H20
- F** Lashing strap 5.00m
- G** Spax screws for attaching the stop-end to the Dokadek panel

Forming downstand beams

Forming drop beams with Dokadek 30 panels



WARNING

- ▶ Transfer of horizontal loads as defined by EN 12812 must be catered for by other measures (e.g. by transferring loads into the structure or using tie-backs).



NOTICE

- Throughout assembly and dismantling of the formwork, it is essential that adequate fall protection is in place at all times. For example, a wheel-around working scaffold.
- Follow all country-specific regulations.



NOTICE

- For forming drop beams, only use the Dokadek panel in the longitudinal direction.

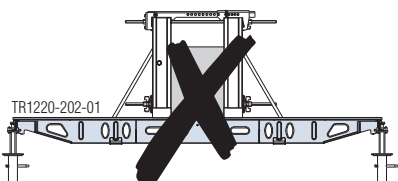

- Centre the drop beam on the panel.
- Allow up to 3 mm extra height for the side formwork.
- Install bracing frames or crossed tie-backs to ensure stability of assembly.
- Handrail-post shoes long are not allowed, because it is not permissible to introduce forces from the side formwork.
- If form-tie points in the drop beam are not allowed, squared timbers have to be placed alongside each other in virtually full-surface contact (see illustration below).

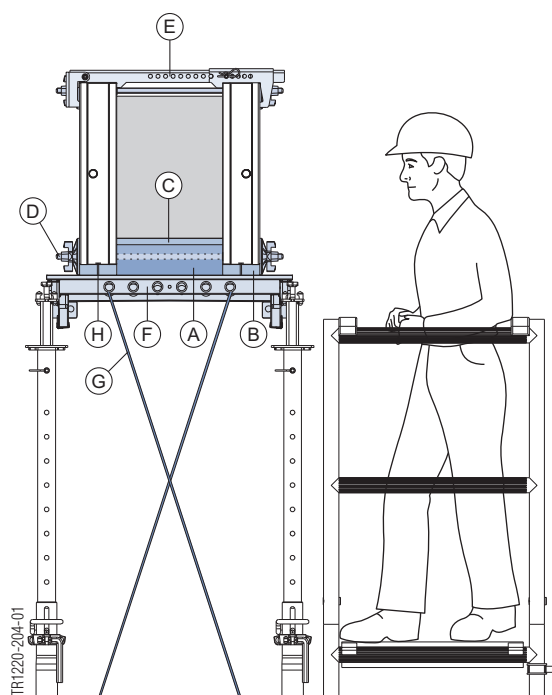

- A Squared timber (site-provided)
- B Squared timber min. 4 cm (site-provided)
- C Formwork sheeting
- D Tie rod 15.0 + Super plate 15.0
- E Framax head anchor
- F Dokadek panel
- G Lashing strap
- H Nail

Drop-beam not integrated into the slab

Drop-beam height up to 50 cm without additional formwork sheeting

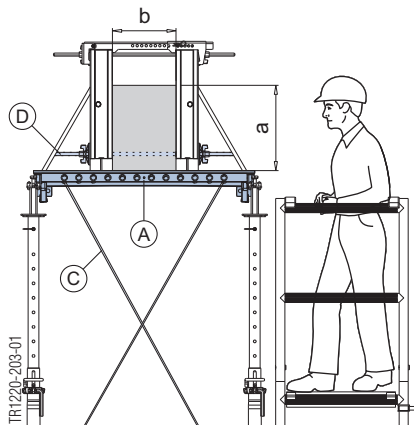

a ... max. drop-beam height 50 cm
b ... max. drop-beam width 60 cm

- A** Dokadek Panel panel 1.22x2.44m or 0.81x2.44m
- C** Lashing strap
- D** Tie rod 15.0 + Super plate 15.0

Drop-beam height > 50 cm to 100 cm with additional formwork sheeting



NOTICE

- The Dokadek panel 1.22x2.44m must not be used for forming drop beams of 50 cm to 100 cm high.

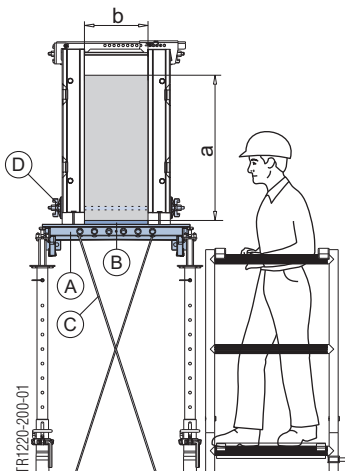

a ... max. drop-beam height 100 cm
b ... max. drop-beam width 45 cm

- A** Dokadek panel 0.81x2.44m
- B** Formwork sheeting (must be used)
- C** Lashing strap
- D** Tie rod 15.0 + Super plate 15.0

Drop-beam integrated into the floor-slab



NOTICE

- The Dokadek panel 1.22x2.44m must not be used for forming drop beams integrated into the slab.
- Additional formwork sheeting must be used.
- Secure the Doka beam H20 in position, for example by nailing.
- Position the structure for forming the drop beam symmetrically on the Dokadek panel.

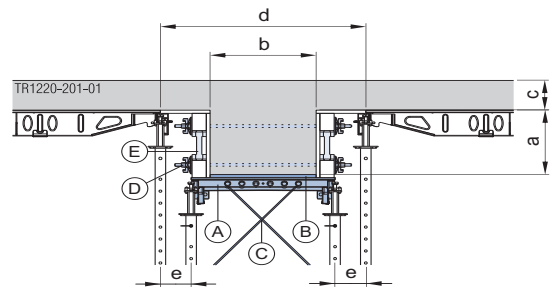

a ... drop beam height
b ... drop beam width
c ... slab thickness
d ... max. 116 cm
e ... max. 17.5 cm

- A** Dokadek panel 0.81x2.44m
- B** Formwork sheeting (must be used)
- C** Lashing strap
- D** Tie rod 15.0 + Super plate 15.0
- E** Doka beam H20

Drop beam	with slab 20 cm	with slab 30 cm
max. height 'a'	45 cm	35 cm
max. width 'b'	≤ 60 cm	≤ 60 cm

Forming drop beams in combination with Dokaflex

Practical example 1

Practical example with bracing frame

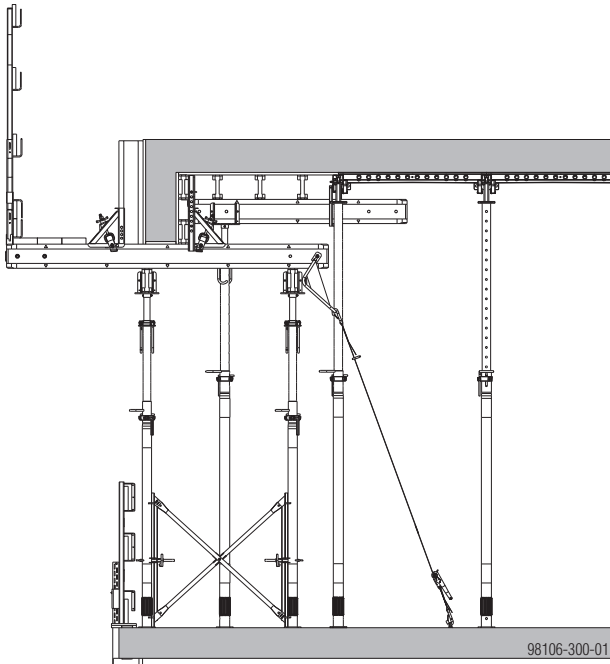

Practical example 2

Practical example with Dokaflex

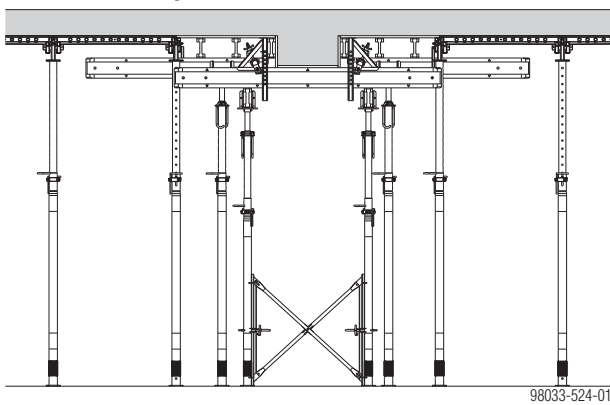

Early stripping without drop head without activation of the slab

The precondition for this is the presence of an upper reinforcement layer (minimum reinforcement is sufficient) to sustain the stresses occurring above the props.

Key to symbols:

- System prop under load
- ↓● Floor prop to be lowered
- ⊙ Temporary reshore to be installed - same type of floor prop as system prop
- ⊙ Temporary reshore already under load
- Lowered floor props

- ▶ Lower all the floor props of the panels in the edge zone of the closure.
- ▶ Install floor props to support the formwork sheets of the closure zone.

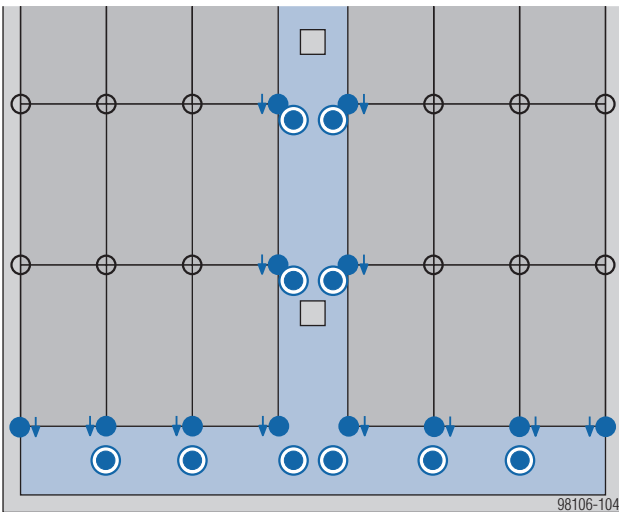

- ▶ With the exception of the formwork sheeting, remove the substructure in the closure zone.
- ▶ Lower the floor prop of the first panel.

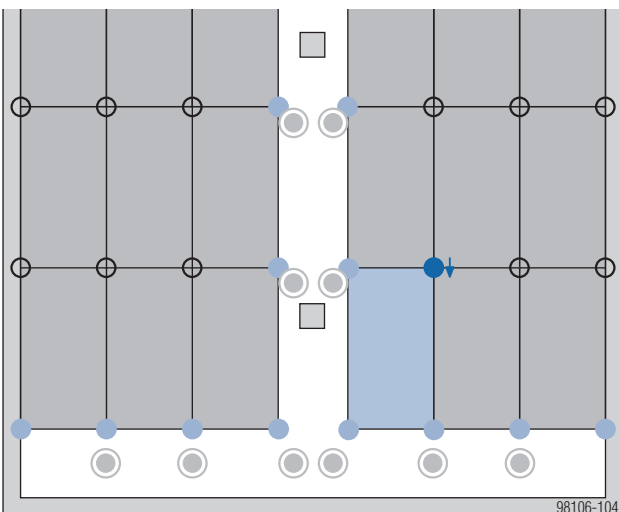

- ▶ Strip out the panel.

- ▶ Install the floor prop for the temporary reshore.

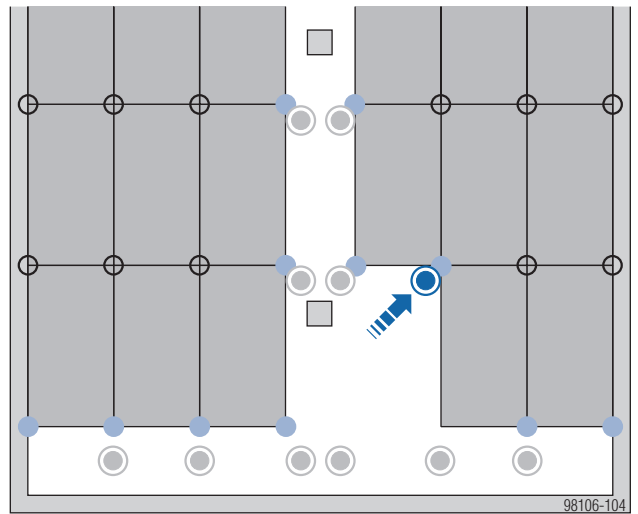

- ▶ Following the same procedure for each panel in turn, lower the floor props of the next panels, strip out the panels and install the floor props for the temporary reshore.

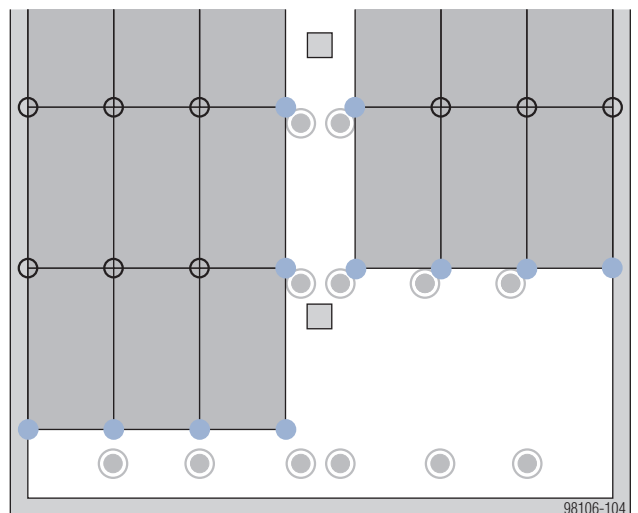

Note:

In the wall zone the extra floor prop for the temporary reshore is not necessary.

- ▶ Follow the same procedure for each row of panels in turn.
- ▶ Lower the floor props.

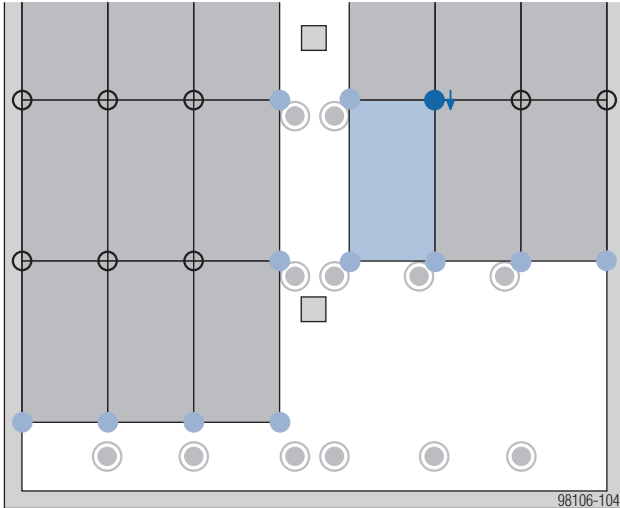

- ▶ Strip out the panel.
- ▶ Install the floor prop for the temporary reshore.

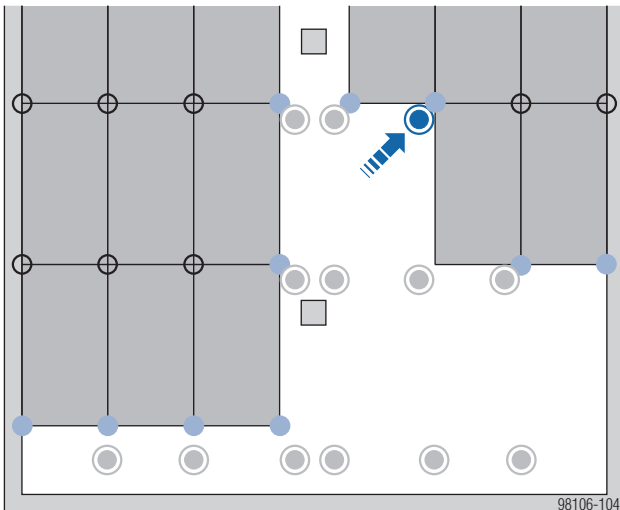

- ▶ Using this principle, strip out the remaining panels and install the floor props for the temporary reshore.

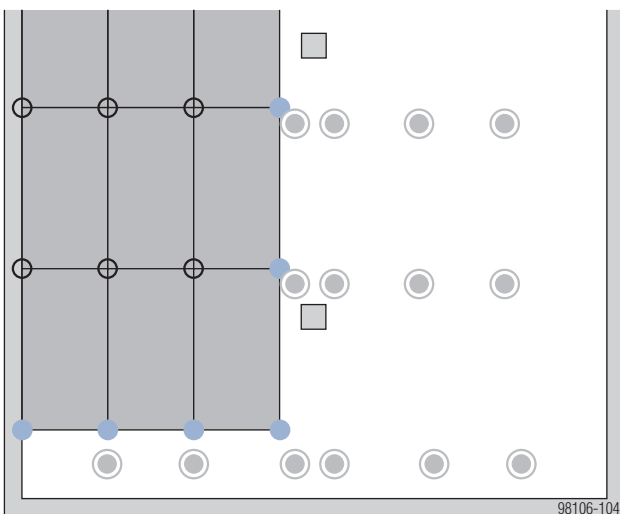

- ▶ Follow the same procedure to strip out the rest of the room. Now only the temporary reshore remains in place.



NOTICE

All systems in which the floor props are re-installed directly after section-by-section stripping, with the result that the floor slab is not activated.

In early stripping without drop head without activation of the slab, the formwork is removed section by section, with the props being re-installed immediately to reshore each section as it is stripped.

One possibility with Dokaflex 1-2-4 is to insert strips of formwork sheeting that can be propped to carry the slab, permitting the actual formwork to be stripped.

Strips of formwork sheeting can also be positioned between tables, and propped.

Important parts of the procedure:

- As each floor prop is placed it has to be pre-stressed by a blow with a hammer against the adjusting nut.
- The entire slab is not stripped at once, because it does not yet have the strength necessary to support its dead load; instead, stripping proceeds by small degrees, section by section.
- At the time of stripping concrete strength must be adequate and for the slab to support its dead load between the floor props. A minimum concrete strength of C8/10 and the presence of top reinforcement suffice for a span of max. 2.6 m between props. Top reinforcement of 1.88 cm²/m is required. If slab thickness is less than 16 cm the top reinforcement has to be at least 2.1 cm²/m.
- Consequently, the slab is not activated.
- Before the next slab is poured, the floor props must be completely stress-relieved, so that they can be subsequently re-used as temporary reshores.
- It is important to allow for adequate curing.

Note:

For more information on correct positioning of the reshoring props, see section [Reshoring props, concrete technology and stripping out](#).

Additional areas of use

Forming inclined floor-slabs

The Dokadek plumbing-strut connector is used for transferring horizontal loads via plumbing struts in situations where Panel floor formwork Dokadek 30 is being used to form e.g. sloping slabs, or sections of slab along exposed (= no side wall) structure-edges.

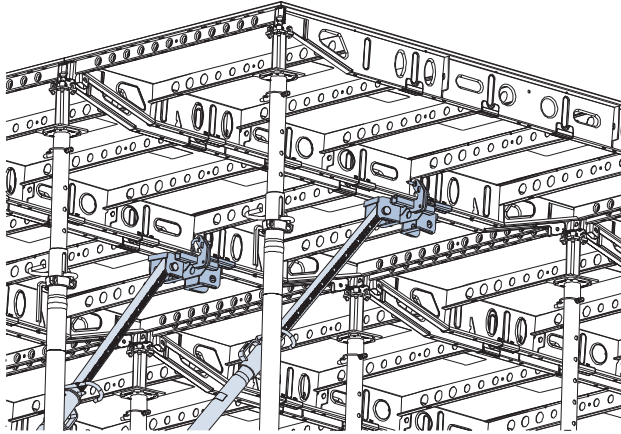

98033-463-02

Permissible compressive force: 13.5 kN
Permissible tensile force: 5 kN

Features:

- For connecting Plumbing struts 340 IB and Plumbing struts 540 IB.
- For use at slab edges instead of tie-backs (e.g. Lashing strap 5.00m).



CAUTION

▶ If the slab is inclined a separate structural-design appraisal is needed, and the necessary additional precautions (e.g. plumbing struts) must be defined.



NOTICE

Transfer of horizontal loads from the following points must be ensured by the plumbing strut connector:

- imperfection
- inclinations
- work operations
- props not vertical
- concrete pressure
- wind



NOTICE

Take the angle of inclination of the working surface into account for the edge protection system! (See EN 13374).



Compensating plates can be used to compensate for floor-slab angles of inclination up to 16 % in all directions.



Follow the directions in the 'Doka express anchor 16x125mm' and 'Lashing strap 5.00m' User Information booklets.

Examples of where the systems are used

Usage situation A: Doka floor props are in the vertical

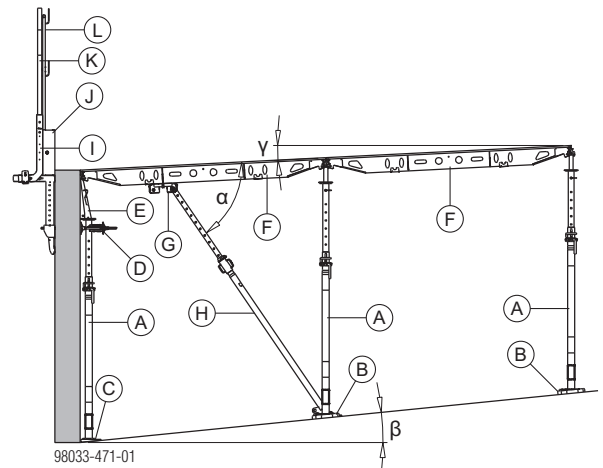

98033-471-01

α ... approx. 60°
 β ... max. 16%
 γ ... max. 5% without drop head and max. 3% with drop-head (in both the longitudinal and transverse directions)

Usage situation B: Doka floor props are at 90° to the formwork plane

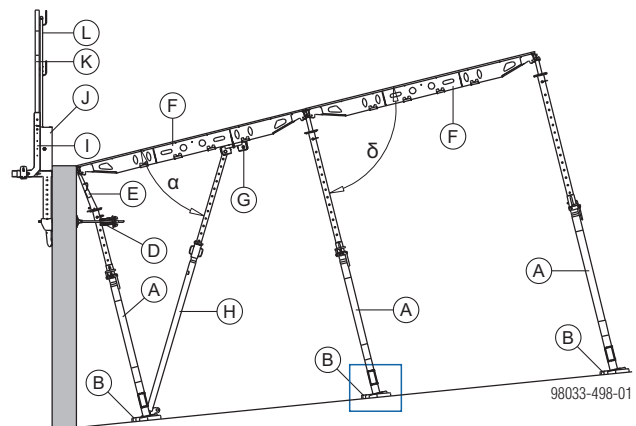

98033-498-01

α ... approx. 60°
 δ ... 90°

Close-up of compensating plate

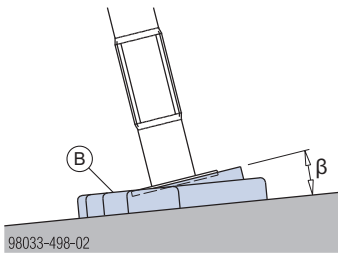

β ... max. 16%

- A Doka floor prop Eurex
- B Compensating plate
- C Wooden wedge
- D Dokadek wall clamp
- E Dokadek wall head
- F Dokadek panel
- G Dokadek plumbing strut connector
- H Plumbing strut 340 IB or Plumbing strut 540 IB
- I Doka floor end-shutter clamp
- J Framax Xlife panel
- K Handrail post XP 1.20m
- L Protective grating XP 2.70x1.20m



NOTICE

Because the floor props are out-of-vertical, additional horizontal forces occur!

Closing the formwork



NOTICE

Ensure the stability of all components and units during all phases of the construction work!

e.g. Usage situation A:

- Set up the Doka floor props and use compensating plates to plumb the props. Use wooden wedges close to the edge of the slab where space is restricted.
- Use Dokadek wall clamps to secure the floor props against tip-over.
- Fit a Dokadek wall head.
- Engage the panel, raise the free end and fix it.

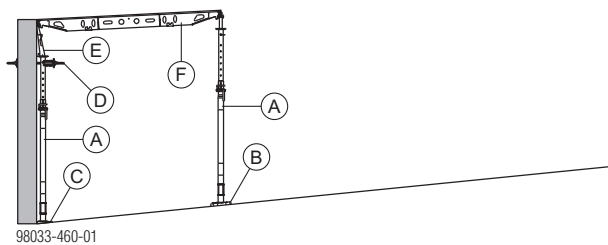

- A Doka floor prop Eurex
- B Compensating plate
- C Wooden wedge
- D Dokadek wall clamp
- E Dokadek wall head
- F Dokadek panel

How to mount the Dokadek plumbing-strut connector



NOTICE

The plumbing-strut connector is only allowed to be fitted 1/3 of the way along the Dokadek panel.

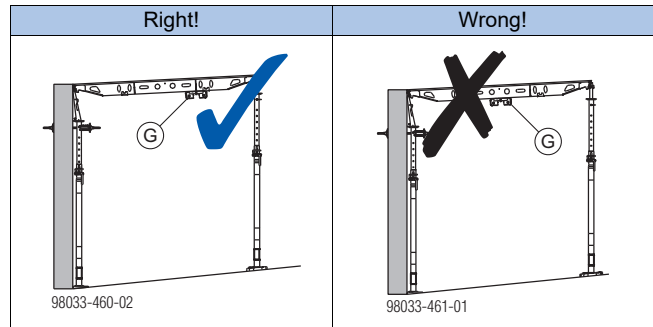

G Dokadek plumbing strut connector

- Pull both safety pins out of the stand-by position.
- Fit the plumbing-strut connector onto the longitudinal girder of the panel.
- Pin the connector to the transverse stiffening plates of the panel with the safety pins.

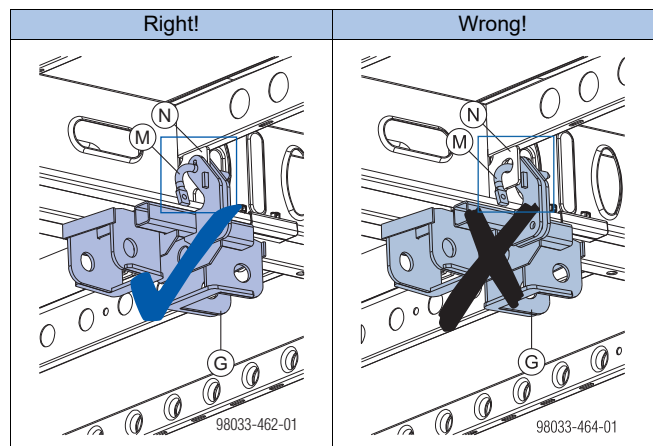

M Safety pin

N Transverse stiffening plate

Correct arrangement of plumbing-strut connectors in free-standing systems



NOTICE

- Fit additional plumbing-strut connectors as statically required.
- On free-standing systems, make sure that the plumbing-strut connectors are fitted facing in alternate directions.

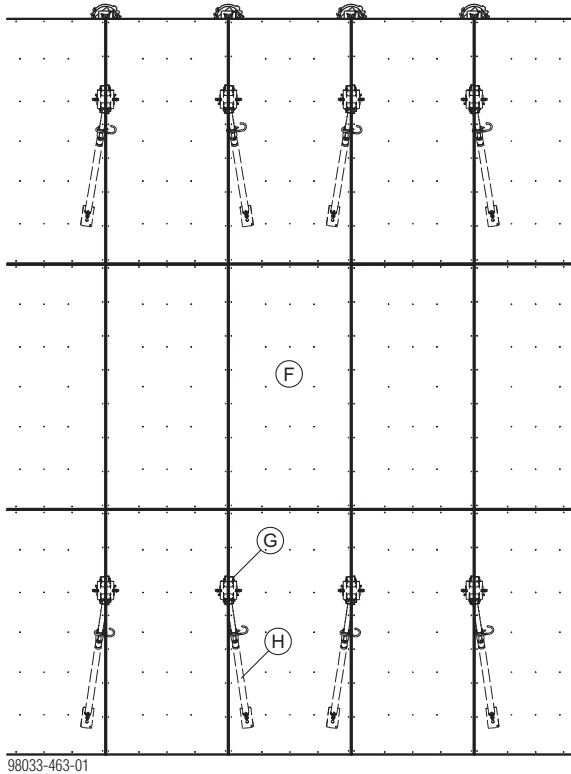

- F Dokadek panel
- G Dokadek plumbing-strut connector
- H Plumbing strut 340 IB or Plumbing strut 540 IB

Attaching the plumbing strut

- Take the fastening bolt out of the plumbing strut.
- Attach the plumbing strut in either the longitudinal or transverse direction, depending on the inclination of the slab.

In longitudinal direction:

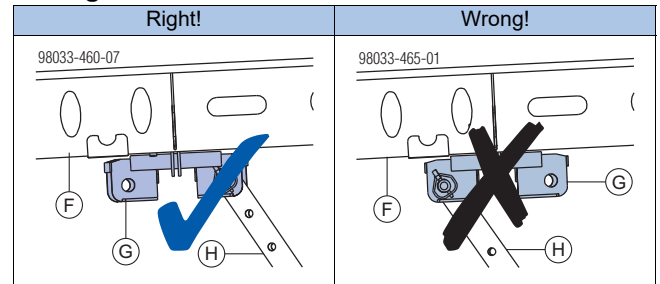

- F Dokadek panel
- G Dokadek plumbing strut connector
- H Plumbing strut 340 IB or Plumbing strut 540 IB

In transverse direction:

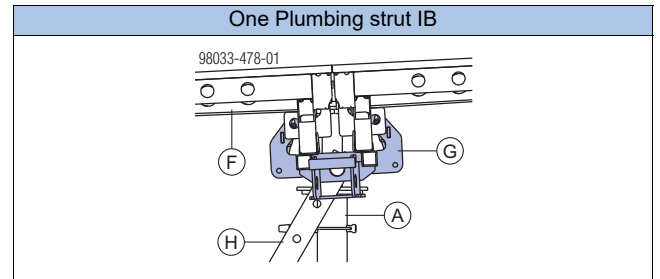

- A Doka floor prop Eurex
- F Dokadek panel
- G Dokadek plumbing strut connector
- H Plumbing strut 340 IB or Plumbing strut 540 IB

- Pin the plumbing strut onto the plumbing-strut connector with the fastening bolt.

Animation:

<https://player.vimeo.com/video/258967173>

- Extend the plumbing strut to the desired length.
- Fix the plumbing strut to the floor with a Doka express anchor.

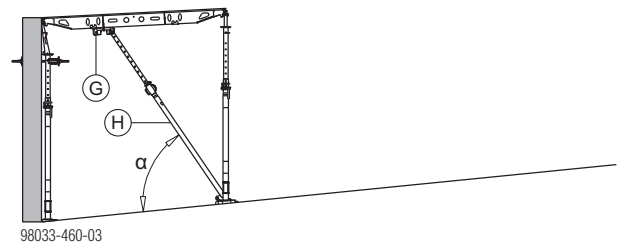

α ... approx. 60°

- G Dokadek plumbing strut connector
- H Plumbing strut 340 IB or Plumbing strut 540 IB



NOTICE

When extending the Plumbing strut IB, only turn the adjusting nut until the strut encounters resistance from above. The panel must not be raised.



Follow the directions in the 'Doka express anchor 16x125mm' User Information booklet!

► Put up further panels.

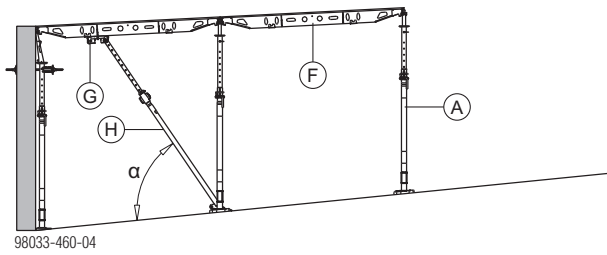

α ... approx. 60°

- A** Doka floor prop Eurex
- F** Dokadek panel
- G** Dokadek plumbing strut connector
- H** Plumbing strut 340 IB or Plumbing strut 540 IB

► Then fit plumbing-strut connectors as needed.
 ► Pin a plumbing strut to each connector and fix each strut to the floor with a Doka express anchor.

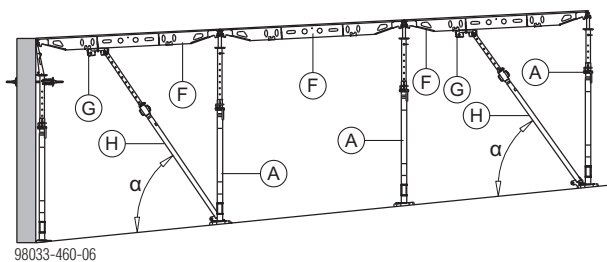

α ... approx. 60°

- A** Doka floor prop Eurex
- F** Dokadek panel
- G** Dokadek plumbing strut connector
- H** Plumbing strut 340 IB or Plumbing strut 540 IB

Pouring

► Before pouring, recheck all floor props.



- The fastening clamp (**A**) has to be pushed all the way into the floor prop.
- Adjusting nut (**B**) has to be tightened into contact with the fastening clamp.



98017-202-01

WARNING

- Only start pouring on a supported panel-field.
- Make sure that pouring is carried out in the correct direction (from 'bottom to top')!

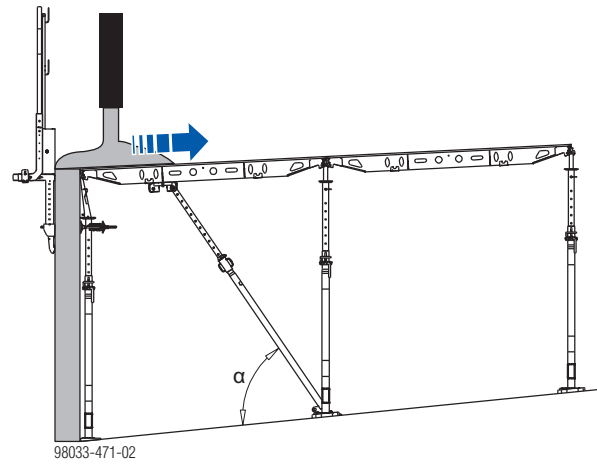

Stripping the formwork



NOTICE

- Comply with the stipulated stripping times.
- Always strip out the formwork in reverse order.
- Also observe section [Reshoring props, concrete technology and stripping out](#).

Forming at slab-edges

Usage situation C:

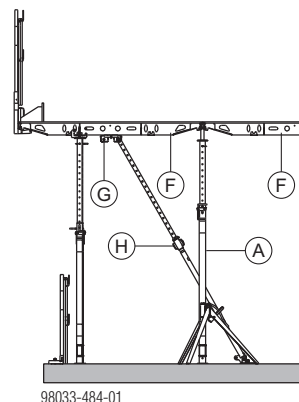

- A** Doka floor prop Eurex
- F** Dokadek panel
- G** Dokadek plumbing-strut connector
- H** Plumbing strut 340 IB or Plumbing strut 540 IB

Note:

A Dokadek plumbing-strut connector can be mounted 1/2-way along the Dokadek panel and used – together with a plumbing strut – as a tie-back.



Follow the directions in the 'Structure edge (Panel floor formwork Dokadek 30)' User Information booklet.

Additional precautions for slab thicknesses of up to 50 cm

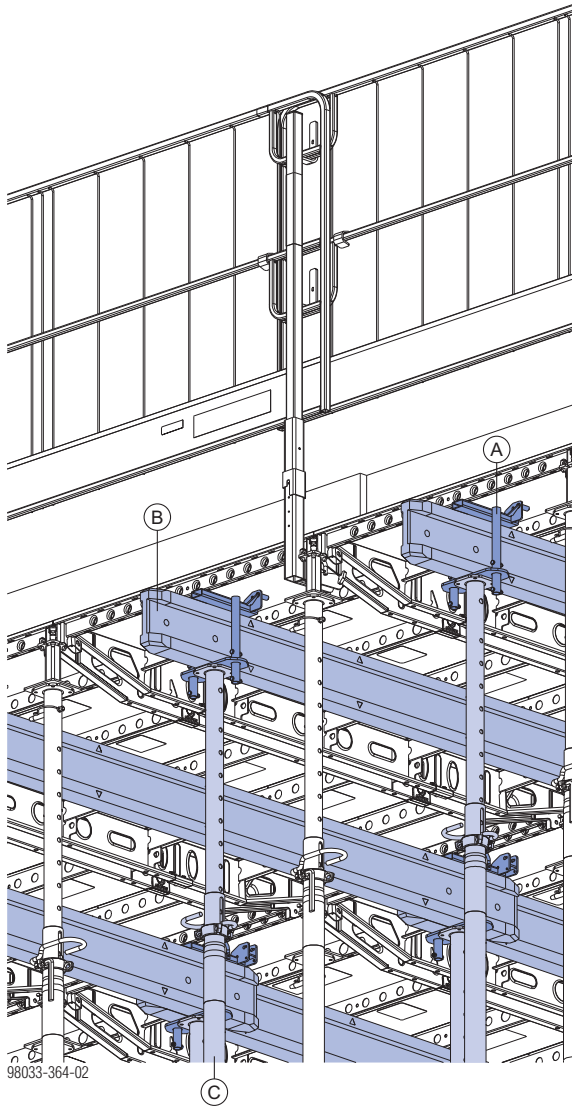

- A** Timber-beam seat H20
- B** Doka beam H20 (recommended length: 2.90m)
- C** Doka floor prop Eurex 30 top

Permitted slab thickness [cm] with additional precautions

Panel size	Floor prop Eurex 30	Flatness deviation as per DIN 18202, Table 3
1.22x2.44m	> 30 - 50	Line 6
0.81x2.44m	> 45 - 50	Line 6



NOTICE

The additional propping is mounted AFTER the formwork has been secured against tip-over.

Mounting additional shores (in the typical zone)

Mounting the Timber beam seat H20 (in the typical zone)

at a panel joint

- ▶ Remove the safety pin of the Timber-beam seat H20, from its stand-by position.

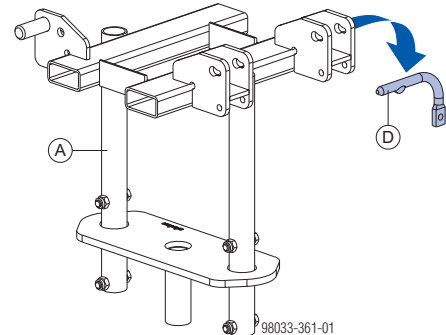

- A** Timber-beam seat H20
- D** Safety pin

- ▶ Mount the Timber-beam seat H20 to the middle of the cross profile of the panel. To do this, insert a d16mm bolt into the 2nd hole of the cross profile (from the middle) of one of the two panels.

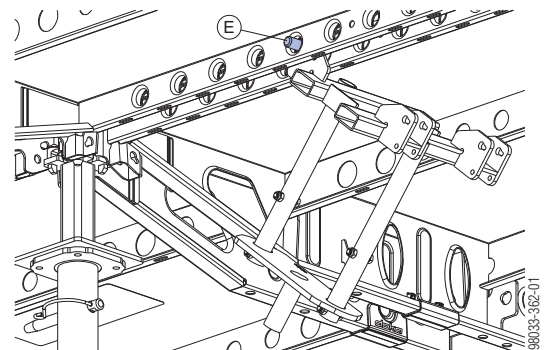

- E** Bolt, d16mm

- ▶ Tilt up the Timber-beam seat H20 and fix it in the cross profile of the other panel, with the safety pin.

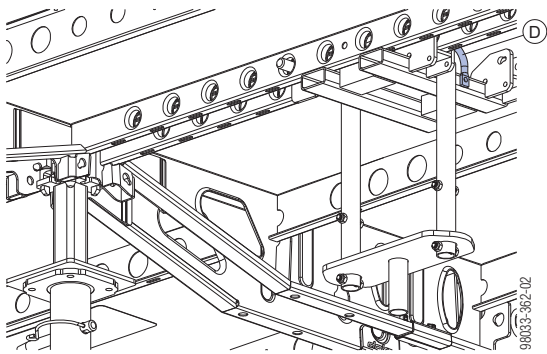

Close-up of safety pin

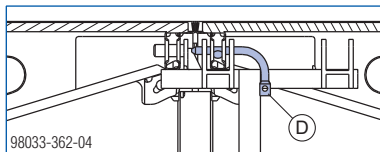

D Safety pin

on an edge panel

- ▶ Remove the safety pin of the Timber-beam seat H20, from its stand-by position.

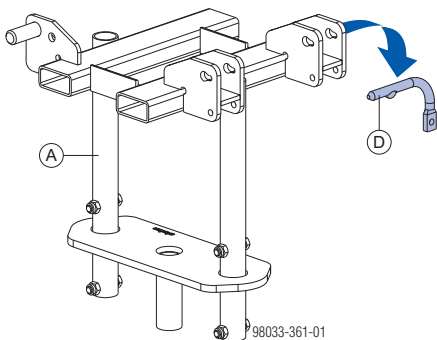

A Timber-beam seat H20
D Safety pin

- ▶ Mount the Timber-beam seat H20 to the middle of the cross profile of the panel. To do this, fix the safety pin in the 2nd hole of the cross profile (from the middle).

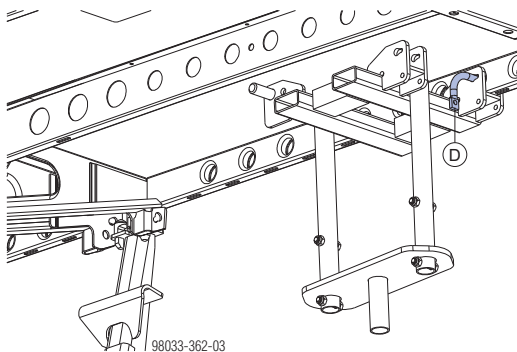

D Safety pin

Inserting Doka beams H20



NOTICE

- ▶ When beams need to be telescoped past each other, always do this in the same Timber beam seat H20.
 - ▶ At the edge of the formwork, the single beam must be resting in the middle of the Timber beam seat H20, and touching the wall.
- ▶ Use the Alu beam fork H20 to insert the Doka beams H20 into the Timber beam seats.

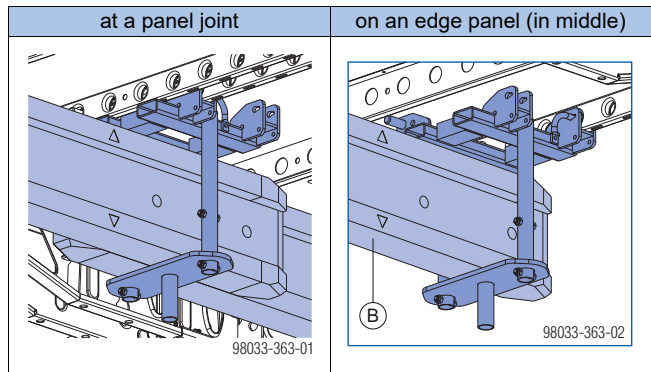

B Doka beam H20 (recommended length: 2.90m)

Animation: <https://player.vimeo.com/video/258743381>

Fitting the floor props



NOTICE

- ▶ The Doka beams H20, the Timber-beam seat H20 and the Dokadek panel must be form-locked.
- ▶ The ends of the beams must be resting solidly on the Timber-beam seats H20.
- ▶ Secure – with tripods – the standard-system floor props that have only 1 panel resting on the heads.
- ▶ When extending the props, only turn the adjusting nut until the prop encounters resistance from above. The panel must NOT be raised.

- ▶ Roughly adjust the height of the floor props, using the fastening clamp.
- ▶ Fit the floor prop into the Timber-beam seat H20, and adjust it.

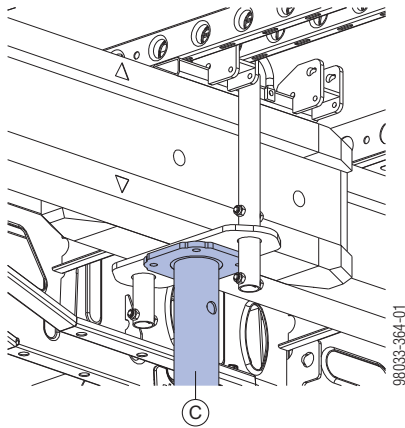

C Doka floor prop Eurex 30 top

- ▶ After fitting all the floor props, raise the Doka beams H20 by turning the adjusting nut on each prop.



- ▶ Do not fit and extend the floor props until the reinforcement has been placed. This lessens the risk of panels being lifted out of the Dokadek heads.

Mounting additional shores (at the structure edge)



For more information, see the 'Structure edge (Panel floor formwork Dokadek 30)' User Information booklet.

Stripping the formwork



NOTICE

- Comply with the stipulated stripping times.
- Always strip out the formwork in reverse order.
- As well as the instructions given here, you must follow the instructions in section [Reshoring props, concrete technology and stripping out.](#)

On slabs with thicknesses of between 30 cm and 50 cm, early removal of all the extra shores from the typical zone is permitted even in cases where service loads and live loads are present. The resulting prop loads are of max. 40 kN per prop, which is permissible for temporary reshores.

Minimum concrete strength required before the extra shores are removed: C8/10

Creating an access alley

To make it easier to transport the panels to their next usage location (e.g. with the DekDrive), it is permitted to remove 1 row of extra shores.

Minimum concrete strength required before the extra shores are removed: C8/10

Practical example

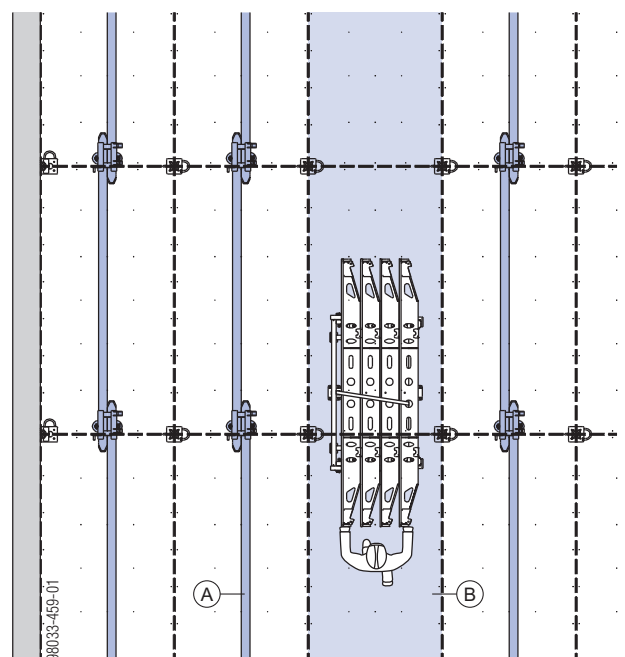

- A Extra shore
- B Access alley

Forming past room-high openings in walls

Where necessary, the slab-forming operations can also incorporate room-high wall openings.



Follow the directions in the 'Doka floor end-shutter clamp' User Information booklet!

Practical examples

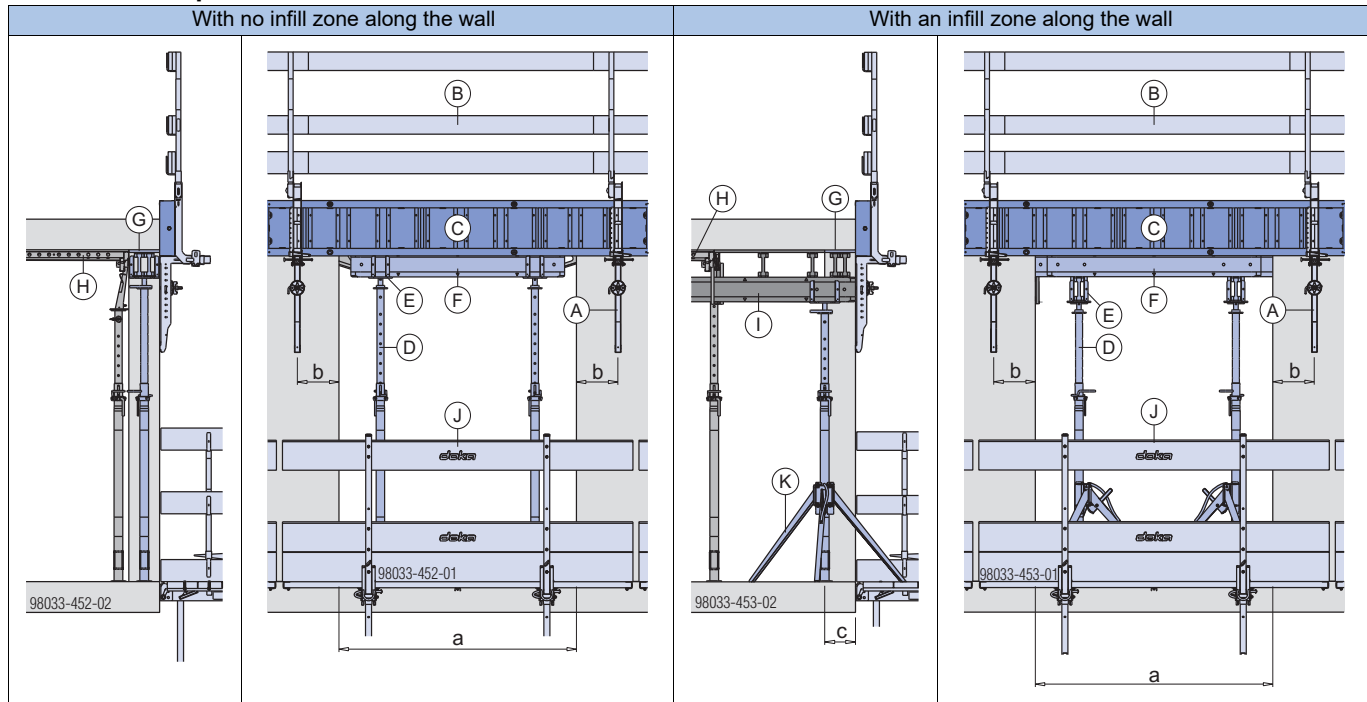

a ... see the 'Doka floor end-shutter clamp' User Information booklet

b ... min. 15 cm

c ... 25 cm

- A** Doka floor end-shutter clamp
- B** Guardrail system
- C** Slab stop-end
- D** Doka floor prop Eurex 30 top
- E** Lowering head H20
- F** Doka beam H20 top
- G** Formwork sheet (nailed-on)
- H** Dokadek panel
- I** Infill zone
- J** Folding platform K or protection platform
- K** Removable folding tripod



- The Doka floor end-shutter clamp can be fixed to the wall by the Bridge edge beam anchor 30kN 15.0.
- Large box-outs can be formed as described in the 'Structure edge (Panel floor formwork Dokadek 30)' User Information booklet.

Using Doka floor props Eurex 20 top / eco / basic and LW

Permitted slab thicknesses [cm]

Eurex 20	250				300				350				400				450		550		700				
	top / eco	basic	top / eco	basic	top / eco	basic	LW	top / eco	basic	LW	top / eco	basic	LW	top / eco	basic	eco	top / eco	top							
Panel width [m]	1.22	0.81	1.22	0.81	1.22	0.81	1.22	0.81	1.22	0.81	1.22	0.81	1.22	0.81	1.22	0.81	1.22	0.81	1.22	0.81					
Room height [m]	7.08	—	—	—	—	—	—	—	—	—	—	—	—	—	—	—	—	—	—	—	24.2	39.1			
	6.98	—	—	—	—	—	—	—	—	—	—	—	—	—	—	—	—	—	—	—	—	25.4	40.8		
	6.88	—	—	—	—	—	—	—	—	—	—	—	—	—	—	—	—	—	—	—	—	26.5	42.3		
	6.78	—	—	—	—	—	—	—	—	—	—	—	—	—	—	—	—	—	—	—	—	27.9	44.2		
	6.68	—	—	—	—	—	—	—	—	—	—	—	—	—	—	—	—	—	—	—	—	—	29.3	46.0	
	6.58	—	—	—	—	—	—	—	—	—	—	—	—	—	—	—	—	—	—	—	—	—	30.6	47.9	
	6.48	—	—	—	—	—	—	—	—	—	—	—	—	—	—	—	—	—	—	—	—	—	32.0	49.9	
	6.38	—	—	—	—	—	—	—	—	—	—	—	—	—	—	—	—	—	—	—	—	—	—	33.3	—
	6.28	—	—	—	—	—	—	—	—	—	—	—	—	—	—	—	—	—	—	—	—	—	—	34.8	—
	6.18	—	—	—	—	—	—	—	—	—	—	—	—	—	—	—	—	—	—	—	—	—	—	—	—
	6.08	—	—	—	—	—	—	—	—	—	—	—	—	—	—	—	—	—	—	—	—	—	—	—	—
	5.98	—	—	—	—	—	—	—	—	—	—	—	—	—	—	—	—	—	—	—	—	—	—	—	—
	5.88	—	—	—	—	—	—	—	—	—	—	—	—	—	—	—	—	—	—	—	—	—	—	—	—
	5.78	—	—	—	—	—	—	—	—	—	—	—	—	—	—	—	—	—	—	—	—	—	—	—	—
	5.68	—	—	—	—	—	—	—	—	—	—	—	—	—	—	—	—	—	—	—	—	—	—	—	—
	5.58	—	—	—	—	—	—	—	—	—	—	—	—	—	—	—	—	—	—	—	—	—	—	—	—
	5.48	—	—	—	—	—	—	—	—	—	—	—	—	—	—	—	—	—	—	—	—	—	21.1	34.9	
	5.38	—	—	—	—	—	—	—	—	—	—	—	—	—	—	—	—	—	—	—	—	—	22.4	36.7	
	5.28	—	—	—	—	—	—	—	—	—	—	—	—	—	—	—	—	—	—	—	—	—	23.7	38.4	
	5.18	—	—	—	—	—	—	—	—	—	—	—	—	—	—	—	—	—	—	—	—	—	25.2	40.4	
	5.08	—	—	—	—	—	—	—	—	—	—	—	—	—	—	—	—	—	—	—	—	—	26.5	42.3	
	4.98	—	—	—	—	—	—	—	—	—	—	—	—	—	—	—	—	—	—	—	—	—	28.0	44.4	
	4.88	—	—	—	—	—	—	—	—	—	—	—	—	—	—	—	—	—	—	—	—	—	30.1	47.1	
	4.78	—	—	—	—	—	—	—	—	—	—	—	—	—	—	—	—	—	—	—	—	—	32.0	49.9	
	4.68	—	—	—	—	—	—	—	—	—	—	—	—	—	—	—	—	—	—	—	—	—	33.7	—	—
	4.58	—	—	—	—	—	—	—	—	—	—	—	—	—	—	—	—	—	—	—	—	—	—	—	—
	4.48	—	—	—	—	—	—	—	—	—	—	—	—	—	—	—	—	—	—	—	—	—	26.7	42.5	
	4.38	—	—	—	—	—	—	—	—	—	—	—	—	—	—	—	—	—	—	—	—	—	28.2	44.5	
	4.28	—	—	—	—	—	—	—	—	—	—	—	—	—	—	—	—	—	—	—	—	—	30.1	47.1	
	4.18	—	—	—	—	—	—	—	—	—	—	—	—	—	—	—	—	—	—	—	—	—	31.8	49.8	
	4.08	—	—	—	—	—	—	—	—	—	—	—	—	—	—	—	—	—	—	—	—	—	33.7	—	—
	3.98	—	—	—	—	—	—	—	—	—	—	—	—	—	—	—	—	—	—	—	—	—	—	—	—
	3.88	—	—	—	—	—	—	—	—	—	—	—	—	—	—	—	—	—	—	—	—	—	21.5	35.4	
	3.78	—	—	—	—	—	—	—	—	—	—	—	—	—	—	—	—	—	—	—	—	—	23.4	38.0	
	3.68	—	—	—	—	—	—	—	—	—	—	—	—	—	—	—	—	—	—	—	—	—	25.3	40.6	
	3.58	—	—	—	—	—	—	—	—	—	—	—	—	—	—	—	—	—	—	—	—	—	27.3	43.4	
	3.48	—	—	—	—	—	—	—	—	—	—	—	—	—	—	—	—	—	—	—	—	—	29.7	46.6	
	3.38	—	—	—	—	—	—	—	—	—	—	—	—	—	—	—	—	—	—	—	—	—	29.7	46.6	
	3.28	—	—	—	—	—	—	—	—	—	—	—	—	—	—	—	—	—	—	—	—	—	31.7	49.6	
	3.18	—	—	—	—	—	—	—	—	—	—	—	—	—	—	—	—	—	—	—	—	—	31.8	49.8	
3.08	—	—	—	—	—	—	—	—	—	—	—	—	—	—	—	—	—	—	—	—	—	31.7	49.6		
2.98	—	—	—	—	—	—	—	—	—	—	—	—	—	—	—	—	—	—	—	—	—	31.7	49.6		
2.88	—	—	—	—	—	—	—	—	—	—	—	—	—	—	—	—	—	—	—	—	—	31.7	49.6		
2.78	—	—	—	—	—	—	—	—	—	—	—	—	—	—	—	—	—	—	—	—	—	31.7	49.6		
2.68	—	—	—	—	—	—	—	—	—	—	—	—	—	—	—	—	—	—	—	—	—	31.7	49.6		
2.58	—	—	—	—	—	—	—	—	—	—	—	—	—	—	—	—	—	—	—	—	—	31.7	49.6		
2.48	—	—	—	—	—	—	—	—	—	—	—	—	—	—	—	—	—	—	—	—	—	31.7	49.6		
2.38	—	—	—	—	—	—	—	—	—	—	—	—	—	—	—	—	—	—	—	—	—	31.7	49.6		
2.28	—	—	—	—	—	—	—	—	—	—	—	—	—	—	—	—	—	—	—	—	—	31.7	49.6		
2.18	—	—	—	—	—	—	—	—	—	—	—	—	—	—	—	—	—	—	—	—	—	31.7	49.6		
2.08	—	—	—	—	—	—	—	—	—	—	—	—	—	—	—	—	—	—	—	—	—	31.7	49.6		
1.98	—	—	—	—	—	—	—	—	—	—	—	—	—	—	—	—	—	—	—	—	—	31.7	49.6		
1.88	—	—	—	—	—	—	—	—	—	—	—	—	—	—	—	—	—	—	—	—	—	31.7	49.6		
1.78	—	—	—	—	—	—	—	—	—	—	—	—	—	—	—	—	—	—	—	—	—	31.7	49.6		

Note:

- The table takes account of the props' higher load-bearing capacity when their extension-length is reduced; for this reason, it is only valid for the room heights and types of props specified.
- Allow for deflections as per DIN 18218 (see section [Ground rules](#)).



Follow the directions in the 'Doka floor prop Eurex 20 top 700' User Information booklet and, for room heights greater than 4.50 m, in the 'Alternative methods of assembly (Panel floor formwork Dokadek 30)' User Information booklet!



WARNING

- ▶ In the typical and infill zones, and/or when mixing Dokadek and Dokaflex, the props used must all be of the same type.
- ▶ It is forbidden to use the Doka floor prop Eco 20!
- ▶ Additional measures, such as those described in section 'Additional precautions for slab thicknesses of up to 50 cm', are forbidden!

Bracing clamp B

Planks can be attached to the floor props as diagonal braces, using the Bracing clamp B.



NOTICE

- Only allowed to be used as a set-up aid.
- Not suitable for sustaining horizontal loads during pouring.
- Always hammer in the wedge from top to bottom!

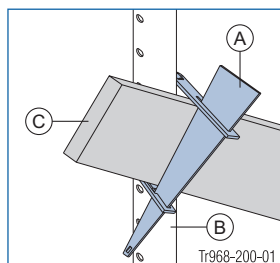

A Bracing clamp B

B Doka floor prop Eurex 20

C Plank

Possible plank/floor-prop combinations with the Bracing clamp B

Plank cross-section [cm]	2.4 x 15		3 x 15		4 x 15		5 x 10		5 x 12		5 x 15	
	Inner tube	Outer tube	Inner tube	Outer tube	Inner tube	Outer tube	Inner tube	Outer tube	Inner tube	Outer tube	Inner tube	Outer tube
Eurex 20 150	—	✓	—	✓	✓	✓	✓	✓	✓	✓	✓	✓
Eurex 20 250	—	✓	—	✓	✓	✓	✓	✓	✓	✓	✓	✓
Eurex 20 300	—	✓	—	✓	✓	✓	✓	✓	✓	✓	✓	✓
Eurex 20 350	—	✓	✓	✓	✓	✓	✓	✓	✓	✓	✓	✓
Eurex 20 400	✓	✓	✓	✓	✓	✓	✓	✓	✓	✓	✓	✓
Eurex 20 450	✓	✓	✓	✓	✓	✓	✓	✓	✓	✓	✓	✓
Eurex 20 550	✓	✓	✓	✓	✓	✓	✓	—	✓	—	✓	—



For bracing possibilities of the Doka floor prop Eurex 20 top 700, see the 'Doka floor prop Eurex 20 top 700' User Information booklet.

General

Combining with other Doka systems

Dokaflex 30 tec and Dokaflex

Dokaflex is the fast and versatile floor-slab formwork for any layout - also for drop beams, stepped floors and filigree slabs. Because the quantities can easily be computed using a slide-rule, no detailed formwork planning work is needed. Any type of form-facing can be used, enabling all architectural wishes regarding the concrete surface to be met.



For more information, please refer to the 'Dokaflex 30 tec' and 'Dokaflex' User Information booklets.

Dokamatic and Dokaflex tables

The Doka tables are pre-assembled, and save on both labour and crane time. With the DoKart, the tables can easily be wheeled across to their next location by just one man working on his own. The system is optimised to give the very shortest forming-times on large areas, and copes well even with varying structural-design and geometrical requirements.

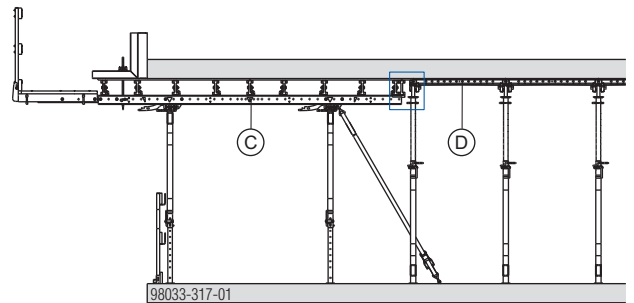

Close-up of extra beam:

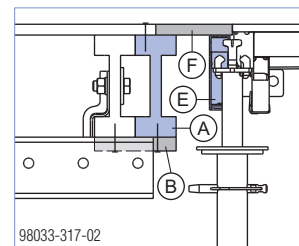

A Doka beam H20

B Nailing board (provided at site)

C Dokamatic table

D Dokadek panel

E Dokadek infill beam

F Formwork sheeting



NOTICE

The beam **(A)** must be pre-mounted!



For more information, see the "Dokamatic table" and "Dokaflex table" User Information booklets.

Transporting, stacking and storing

Dokadek panel pallets

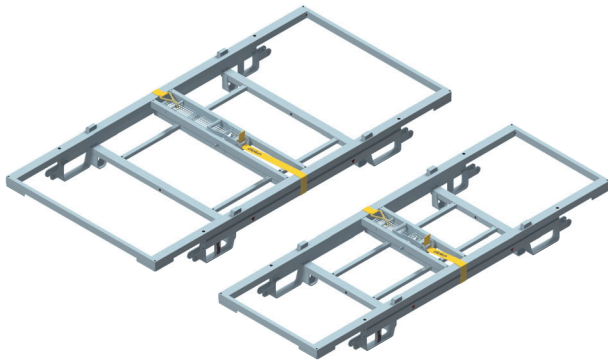

Storage and transport device for Dokadek panels.



CAUTION

- ▶ Observe the maximum number of Dokadek panels (see tables).
- ▶ It is forbidden to stack panels of different widths on the same pallet.



NOTICE

- The type plate must be in place and clearly legible.
- Load the items centrally.

Dokadek panels	
1.22x2.44m 0.81x2.44m	1.22x1.22m 0.81x1.22m
 98033-288-01	 98033-528-02

h ... max. stack height (see tables)

Dokadek panel pallet 1.22x2.44m

	Dokadek panel	
	1.22x2.44m	1.22x1.22m
Max. n° of panels	11	12 (2x6)
Max. stack height h [cm]	215	128
Permissible load-bearing capacity	650 kg (1430 lbs)	
Permissible imposed stacking load	1450 kg (3200 lbs)	

Dokadek panel pallet 0.81x2.44m

	Dokadek panel	
	0.81x2.44m	0.81x1.22m
Max. n° of panels	11	12 (2x6)
Max. stack height h [cm]	215	128
Permissible load-bearing capacity	550 kg (1210 lbs)	
Permissible imposed stacking load	1250 kg (2755 lbs)	

Stacking the panels

Dokadek panels 1.22x2.44m or 0.81x2.44m

- ▶ Undo the lashing strap and remove the cover.
- ▶ Set down the 1st panel on the middle of the pallet.

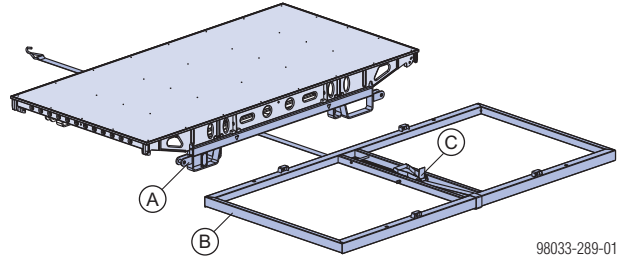

98033-289-01

A Pallet

B Cover (unlosable)

C Lashing strap



Make sure that the panel is correctly positioned!

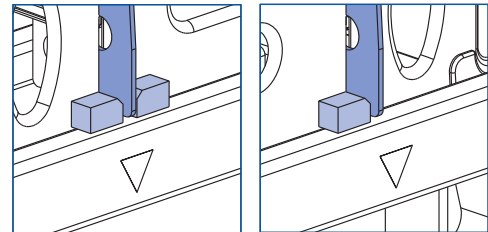

98033-288-02

- ▶ Set down further panels, exactly over one another.
- ▶ Place the cover over the top panel and tighten the stack with the lashing strap.

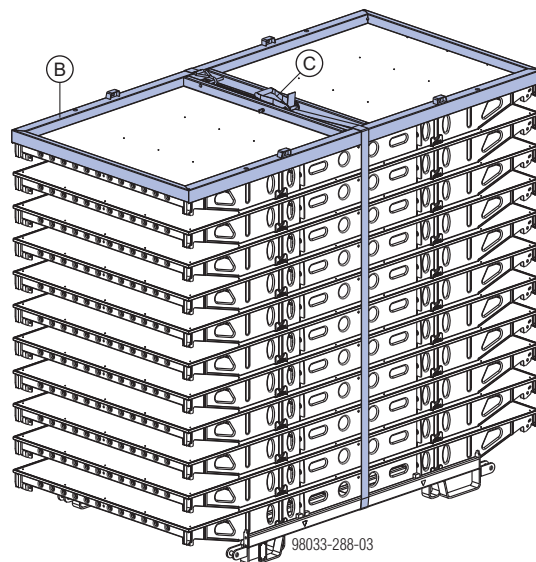

98033-288-03



- We recommend using a standard platform ladder to make it easier to operate the lashing strap.
- Coil up the end of the lashing strap and put it in the storage tray (D) .

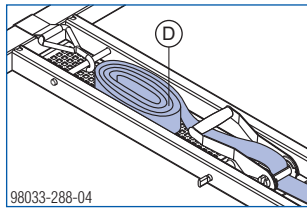

98033-288-04

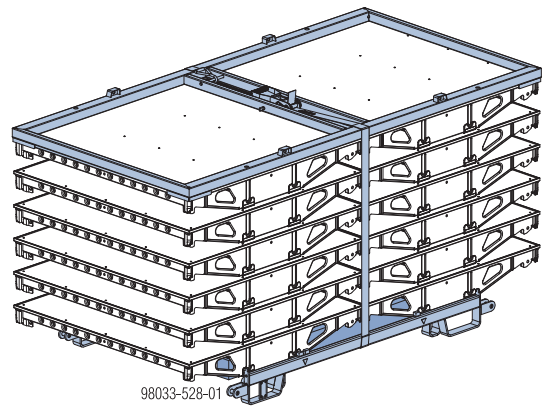

98033-528-01

Dokadek panels 1.22x1.22m or 0.81x1.22m

The Dokadek supporting timber 1.73m (HT) acts as a support for the Dokadek 30 panels 1.22x1.22m and 0.81x1.22m in Dokadek panel pallets (2 supporting timbers per panel pallet).

Dokadek panel pallet as a storage unit

Max. number of units on top of one another

N° of Dokadek panels in the pallet	Outdoors (on the site)	Indoors
	Floor gradients up to 3%	Floor gradients up to 1%
Dokadek panel 1.22x2.44m or 0.81x2.44m		
≤ 6	1	3
> 6	1	2
Dokadek panel 1.22x1.22m or 0.81x1.22m		
≤ 12	1	3



WARNING

▶ Always stack the panels on the pallet in pairs.

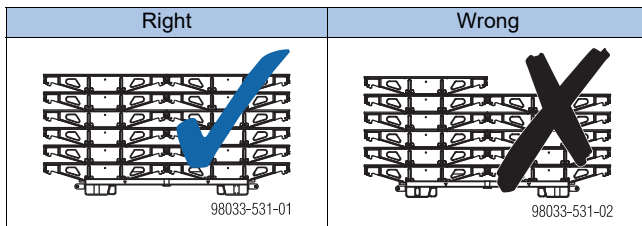

98033-531-01

98033-531-02

Illustrations without pallet covers



NOTICE

- 2 supporting timbers are needed per pallet.
- Store the panel pallet and supporting timbers separately.

All the other work steps are the same as for large-sized panels.

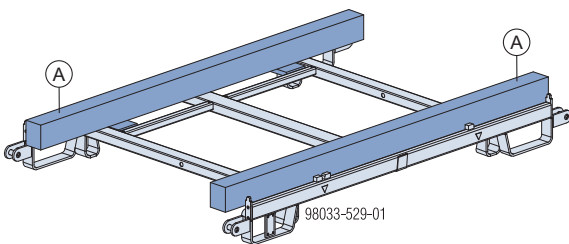

98033-529-01

A Dokadek supp. timber 1.73 (HT)

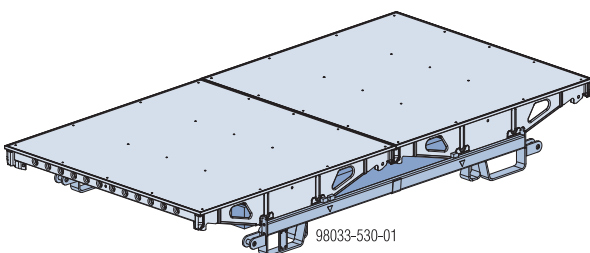

98033-530-01

Dokadek panel pallet as a transport device

Suitable transport appliances:

- Crane
- Forklift truck
- Pallet truck
- [Attachable wheelset](#)

Lifting by crane



NOTICE

- Multi-trip packaging items may only be lifted one at a time.
- Secure the stack of panels with the cover and the lashing strap.
- Use suitable lifting chains (do not exceed the permissible working load limit).
- Sling angle β max. 30°!

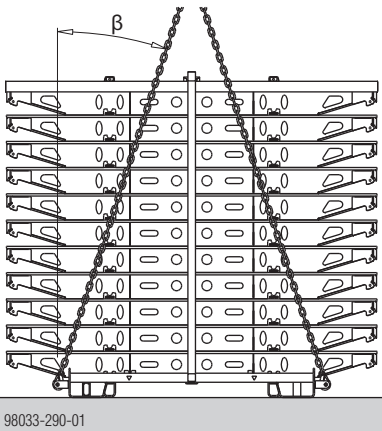

- Lifting the panels without a panel pallet is only allowed using 4 separate lifting slings, with a protective sleeve (A) over every corner.

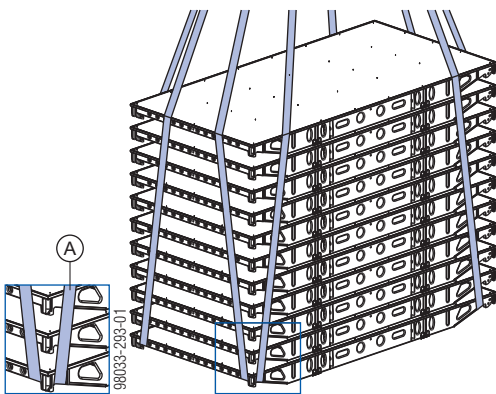

Shifting with forklift or pallet stacking truck



NOTICE

- Multi-trip packaging items may only be lifted one at a time.
- Load the items centrally.
- Secure the stack of panels with the cover and the lashing strap.

Correct loading of trucks (lorries)



NOTICE

- **Ideally**, arrange the Dokadek panel pallets at right-angles to the cargo floor. (A)
- If the stacks are not of the same height, then the panels **must always be arranged at right angles to the cargo floor.**

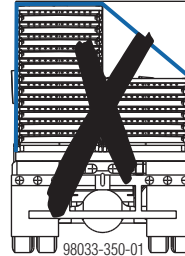

- Load the truck from front to back with Dokadek panel pallets. (B)
- Arrange the Dokadek panel pallets so that they are positively locked. (C)
- Secure every Dokadek panel pallet with a lashing strap. (D)

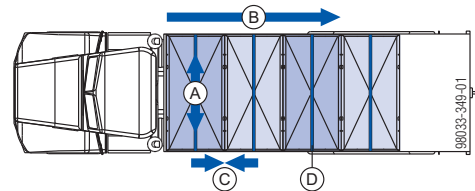

Animation:

<https://player.vimeo.com/video/256036570>

- If the pallets have to be loaded lengthways to the cargo floor, secure each pair of Dokadek panel pallets with 2 lashing straps. (D)

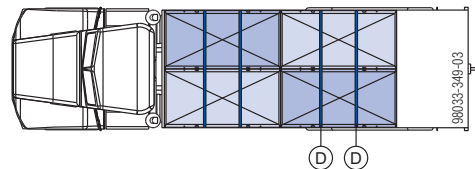

Animation:

<https://player.vimeo.com/video/256029891>



With closely stacked panel bundles:

- ▶ lever-up a panel bundle (e.g. with a squared timber (D)), to make a space for threading in the slings.

Caution!

Always make sure that the panel bundle remains stable!

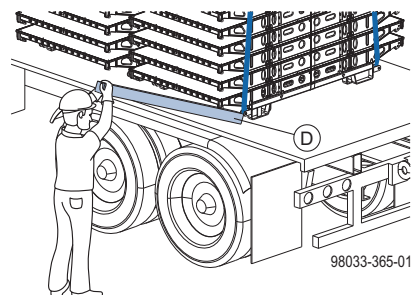

Wooden pallet 1.20x0.80m (HT)

Is used for packaging and storing Dokadek panels 1.22x1.22m or 0.81x1.22m.

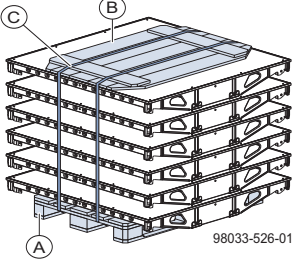
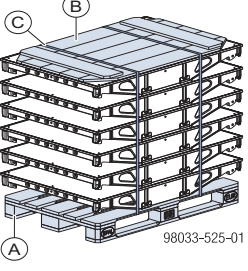
1.22x1.22m	0.81x1.22m
	
Number of panels per unit	
6	
Max. number of units on top of one another	
Outdoors (on the site) max. floor gradient of 3%	
1	
Indoors max. floor gradient of 1%	
4	3
A Wooden pallet 1.20x0.80m (HT)	
B Crate cover 1.20x0.80m (HT)	
C Strapping tape	

Attachable wheelset

Product description

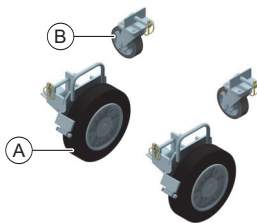

- A 2 x heavy-duty wheel
- B 2 x swivel caster

The Attachable wheelset turns the panel pallet into a fast and manoeuvrable transport device. Suitable for drive-through access openings > 150 cm.



NOTICE

- When the panel pallet is parked or is being shifted by crane or forklift, always apply the fixing brake.
- When setting down a panel pallet with loosely stacked panels, secure these against wind liftout (e.g. by strapping them together).

Wheeling



NOTICE

- Max. gradient of floor 3%.
- Max. travel speed: 4 km/h (walking pace)
- Either close structure openings with decking of adequate strength secured so that it cannot slip out of place, or cordon off the openings with edge railings of adequate strength!
- Keep the travel route clean and free of any obstacles.
- It is forbidden to use any other mechanical assistance for the travelling operation!
- It is forbidden to wheel panel pallets that have been stacked on top of one another!
- Where necessary, secure loosely stacked panels so that they cannot slip.

Lifting by crane

The Attachable wheelset can stay fixed to the Dokadek panel pallet while it is being lifted.



NOTICE

- Secure the stack of panels with the cover and the lashing strap.

► Before attaching the lifting chain, check that:



- the fixing brake is applied
- linch pins have been fitted to the fastening bolts of the heavy-duty wheels and the swivel casters.

Assembly

Heavy-duty wheel

- Apply the fixing brake on the heavy-duty wheel.
- Working from below, push the heavy-duty wheel onto the longitudinal profile of the panel pallet and fix it in place with a fastening bolt and linch pin.

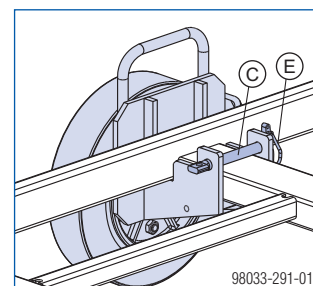

If necessary, the braking force can be adjusted with the setting screw (w/f 24).

Castor wheel

- ▶ Working from the outside, push the wheel-pin of the swivel caster into the hole in the cross profile, and secure it with a linch pin.

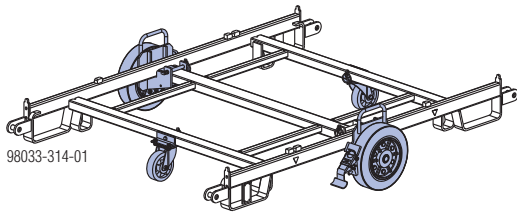
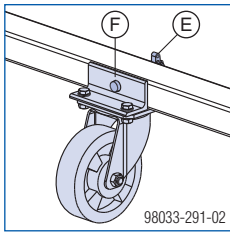

- A Heavy-duty wheel
- B Castor wheel
- C Fastening pin
- E Linch pin
- F Wheel-pin

Animation:

<https://player.vimeo.com/video/262156196>

Variant 1: Panels stacked loosely

- ▶ Place the cover on the panel pallet and tighten it with the lashing strap.

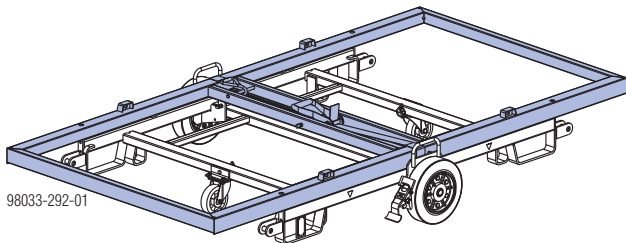

Make sure it is in the correct position!

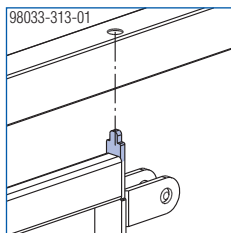

Coil up the end of the lashing strap and put it in the storage tray (D) .

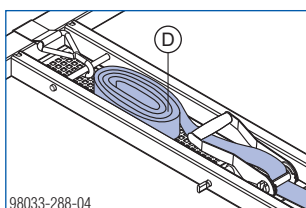

- ▶ Place the 1st panel on the middle of the cover.



Make sure it is in the correct position!

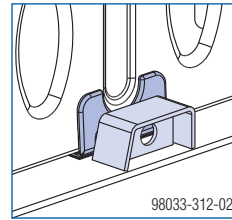

▶ Max. number of loose Dokadek panels: 8

- ▶ Set down further panels, exactly over one another.

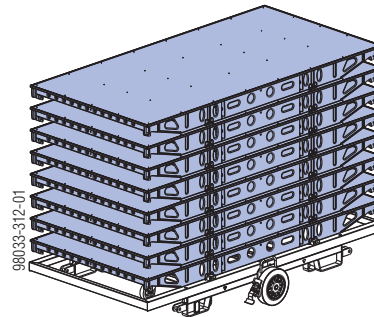

Variant 2: Panels secured and stacked with the cover and the lashing strap

- ▶ See section [Dokadek panel pallets](#)

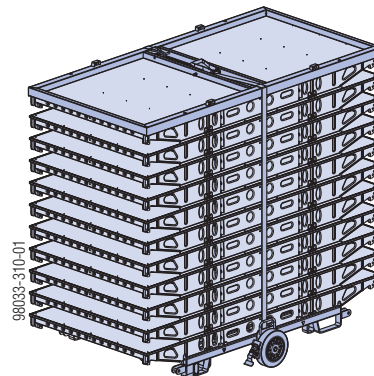

DekDrive

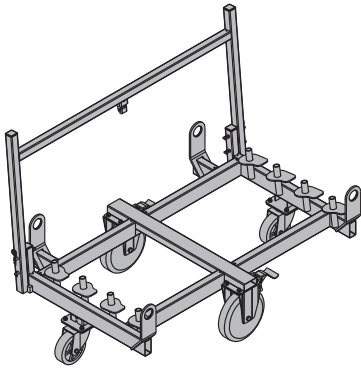

Transport device for Dokadek panels

- durable
- stackable
- Suitable for drive-through access openings > 90 cm.
- state in which delivered and transported: railing folded down

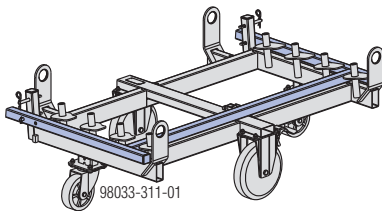

Max. number of Dokadek panels: 4



NOTICE

- The type plate must be in place and clearly legible.
- Load the items centrally.
- It is allowed to stack panels of different widths.
- Not suitable for use as a storage unit.
- When the DekDrive is parked or is being crane-lifted, always apply the fixing brake.
- Always secure the panels with webbing.

Loading the DekDrive

- ▶ Apply the fixing brake on the heavy-duty wheel.
- ▶ Remove the top spring cotters and self-locking pins, at both ends of the DekDrive.

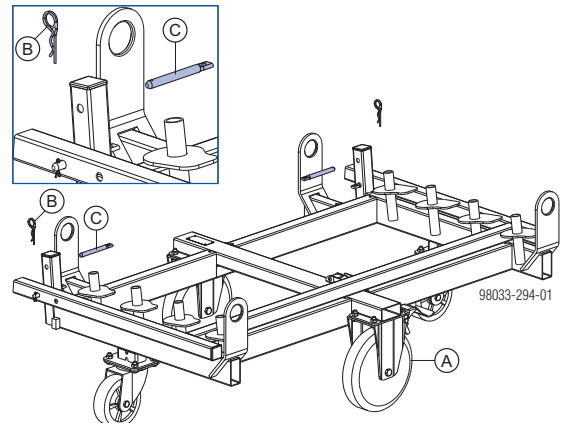

- ▶ Tilt up the railing and secure it at both ends with self-locking pins and spring cotters.

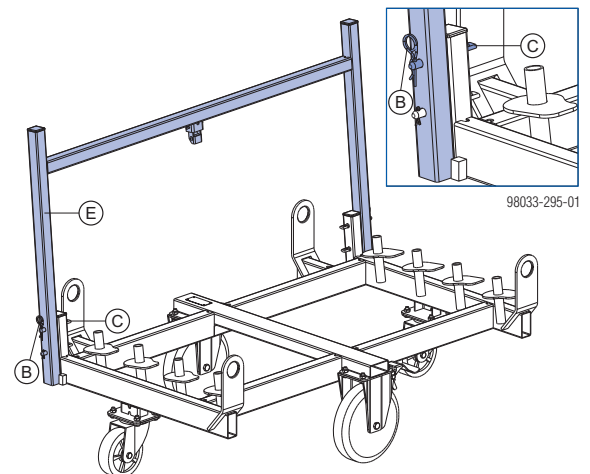

- ▶ Starting at the railing side, push the Dokadek panels centrally onto the holding pins (always with the formwork sheeting toward the railing).

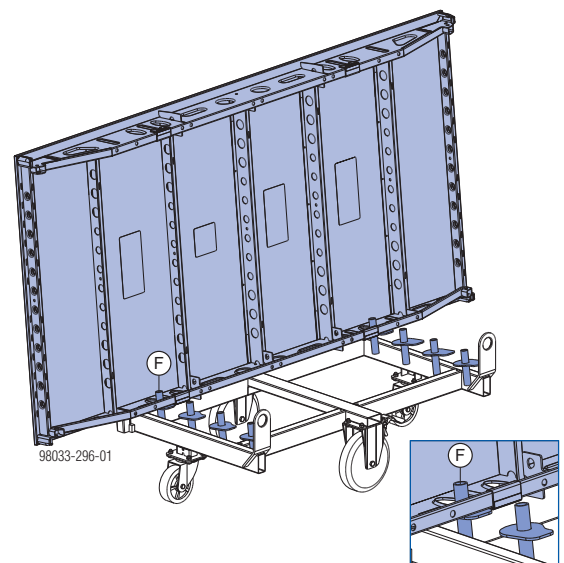

- ▶ Secure the panels with webbing. Fit the hook into one of the openings in the longitudinal profile of the front (i.e. outermost) panel, and tighten the webbing.

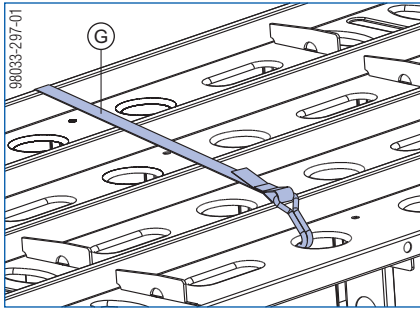

- A Heavy-duty wheel
- B Spring cotter
- C Self-locking pin
- E Railing
- F Holding pin
- G Webbing

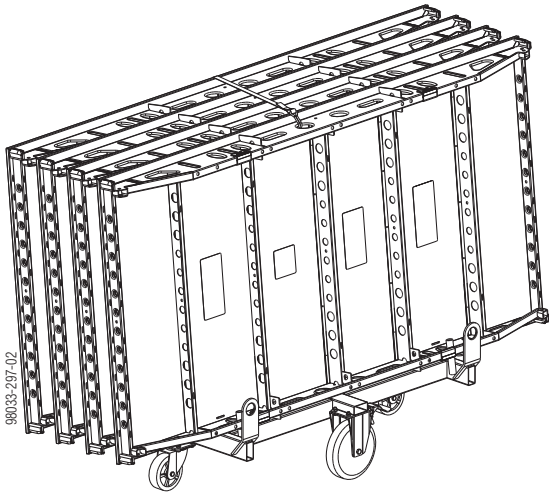

Animation: <https://player.vimeo.com/video/262155511>

Wheeling



NOTICE

- Max. gradient of floor 3%.
- Max. travel speed: 4 km/h (walking pace)
- Either close structure openings with decking of adequate strength secured so that it cannot slip out of place, or cordon off the openings with edge railings of adequate strength!
- Keep the travel route clean and free of any obstacles.
- It is forbidden to use any other mechanical assistance for the travelling operation!

Lifting by crane



NOTICE

- Use suitable lifting chains (do not exceed the permissible working load limit), e.g.: Doka 4-part chain 3.20m
- DekDrives may only be lifted one at a time.
- Sling angle β max. 30°!

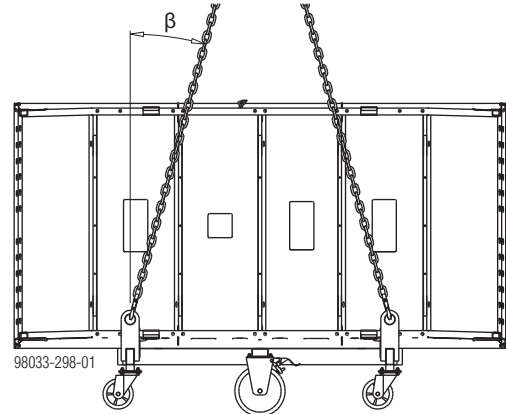

- ▶ Before attaching the lifting chain, check that:



- the fixing brake is applied

Alternative transport options

With timber trolley

A standard timber trolley provides a safe and easy way of moving slab panels without any great physical effort.

Features:

- Clamping jaws
- Clamping sides, felt-padded on inside
- The weight of the material being transported securely closes the clamping mechanism

Designation: M-Timber trolley 170mm-CT

Weight: 7.0 kg

Dimensions:

39 x 31 x 35 cm (L x W x H) width including wheels

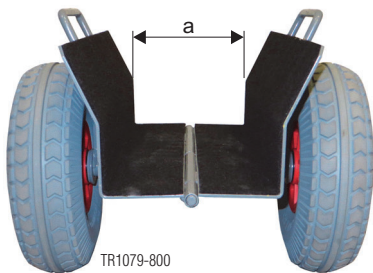

TR1079-800

a ... 170 mm

Permissible load-bearing capacity: 300 kg

State during transport



TR1079-801

A M-Timber trolley 170 mm-CT

How to load

- ▶ Position the Timber trolley beside the Dokadek panel, midway along the panel.

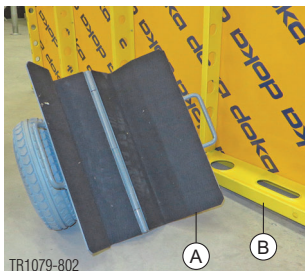

TR1079-802

A M-Timber trolley 170 mm-CT

B Dokadek panel

- ▶ Lift one end of the Dokadek panel, lower the panel centred on to the Timber trolley and wheel it to the desired location.

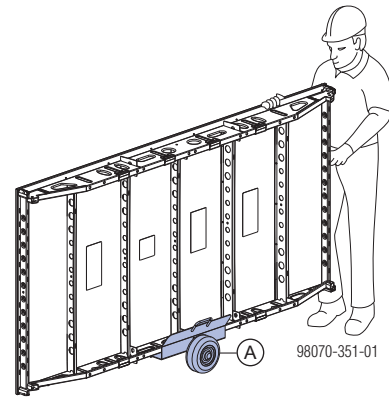

98070-351-01

A M-Timber trolley 170 mm-CT

Manual transport



With the aid of 2 tie rods (each min. 1.00 m long) (A), Dokadek panels can also be transported easily by hand.

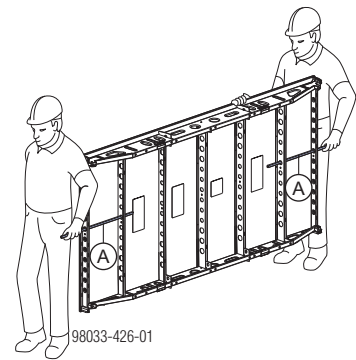

98033-426-01

Dokadek infill-beam pallet

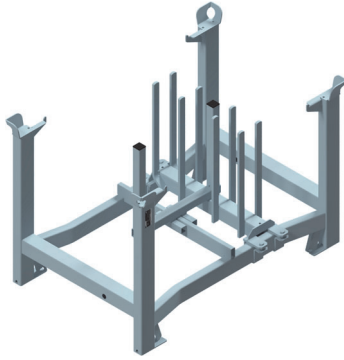

Storage and transport device for Dokadek infill beams. Infill beams 2.44m and 1.22m are supplied ex-works in the infill-beam pallet, while Infill beams 0.81m are supplied in the Doka multi-trip transport box 1.20x0.80m.

Max. number of Dokadek infill beams: 44
 Permissible load-bearing capacity: 800 kg
 Permissible imposed stacking load: 5900 kg



NOTICE

- Load Infill beams 2.44m and 1.22m onto the pallet centrally, so that they are braced against the uprights of the pallet.
- Stacked multi-trip boxes or pallets must have the heaviest boxes at the bottom and the lightest at the top!
- Always stack in complete layers.

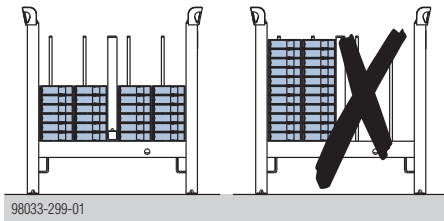

- It is permitted to stack infill beams of different lengths on the same pallet.
 - When the pallet is transported by lorry, Infill beams 0.81m (A) must be stacked on the inside.

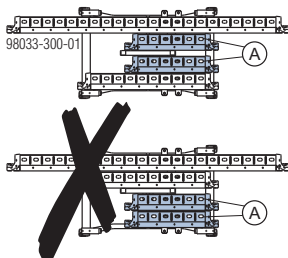

- Before the infill beams are transported by lorry, they must be firmly connected to the pallet, e.g. by bundling with steel strapping.
- The type plate must be in place and clearly legible.

Using the Dokadek infill-beam pallet as a storage unit

Max. number of units on top of one another

Outdoors (on the site) Floor gradients up to 3%	Indoors Floor gradients up to 1%
2	6
It is not allowed to stack empty multi-trip boxes or pallets on top of one another!	



NOTICE

- Stacked multi-trip boxes or pallets must have the heaviest boxes at the bottom and the lightest at the top!
- Castor wheels or bolt-on castor sets must not be fitted to the bottom multi-trip packaging in the stack.
- Secure multi-trip packagings with installed castor wheels using the fixing brake when parking.

Using the Dokadek infill-beam pallet as a transport device

Suitable transport appliances:

- Crane
- Forklift truck
- Pallet truck
- [Universal castor wheel for transport pallet](#)
- [Bolt-on castor set B](#)

Lifting by crane



NOTICE

- Multi-trip packaging items must be lifted individually.
- Use suitable lifting chains (e.g. Doka 4-part chain 3.20m). Do not exceed the maximum working load limit.
- Load the items centrally.
- When lifting units to which Bolt-on castor sets B have been attached, you must also follow the directions in the 'Bolt-on castor set B' User information booklet!
- Sling angle β max. 30°!

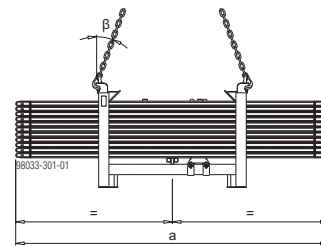

a ... 244 cm or 122 cm

Repositioning by forklift truck or pallet stacking truck



NOTICE

- Load the items centrally.

Doka skeleton transport box 1.70x0.80m



Storage and transport device for small items. To make the Doka skeleton transport box easier to load and unload, one of its sidewalls can be opened.

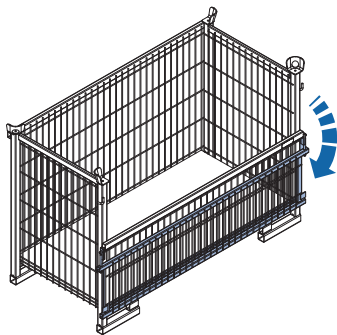

Permissible load-bearing capacity: 700 kg (1540 lbs)
 Permissible imposed stacking load: 3150 kg (6950 lbs)

Using Doka skeleton transport boxes 1.70x0.80m as storage units

Max. number of units on top of one another

Outdoors (on the site) Floor gradients up to 3%	Indoors Floor gradients up to 1%
2	5
It is not allowed to stack empty multi-trip boxes or pallets on top of one another!	



NOTICE

- Stacked multi-trip boxes or pallets must have the heaviest boxes at the bottom and the lightest at the top!
- Castor wheels must not be fitted to the bottom multi-trip packaging in the stack.
- Secure multi-trip packagings with installed castor wheels using the fixing brake when parking.

Using Doka skeleton transport boxes 1.70x0.80m as transport devices

Suitable transport appliances:

- Crane
- Forklift truck
- Pallet truck
- [Universal castor wheel for transport pallet](#)

Lifting by crane



NOTICE

- Multi-trip packaging items must be lifted individually.
- Only lift the boxes when their sidewalls are closed!
- Use suitable lifting chains:
 - e.g. Doka 4-part chain 3.20m
 - Do not exceed the permitted working load limit of the lifting chains.
- Sling angle β max. 30°!

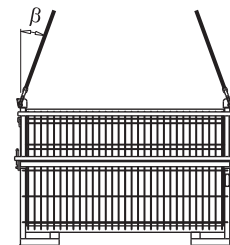

9234-203-01

Repositioning by forklift truck or pallet stacking truck

The forks can be inserted under either the broadside or the narrowside of the containers.

Doka multi-trip transport box

Storage and transport device for small items

Doka multi-trip transport box 1.20x0.80m

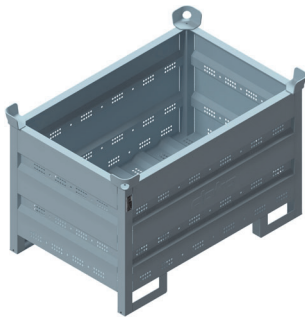

Permissible load-bearing capacity: 750 kg (1650 lbs)
 Permissible imposed stacking load: 7200 kg (15870 lbs)

Using Doka multi-trip transport boxes as storage units

Max. number of units on top of one another

Outdoors (on the site) Floor gradients up to 3%		Indoors Floor gradients up to 1%	
Doka multi-trip transport box 1.20x0.80m	Doka multi-trip transport box 1.20x0.80x0.41m	Doka multi-trip transport box 1.20x0.80m	Doka multi-trip transport box 1.20x0.80x0.41m
3	5	6	10
It is not allowed to stack empty multi-trip boxes or pallets on top of one another!			

Permissible load-bearing capacity: 1500 kg (3300 lbs)
 Permissible imposed stacking load: 7850 kg (17300 lbs)

Different items in the Doka multi-trip transport box can be kept separate with the **Multi-trip transport box partitions 1.20m or 0.80m**.

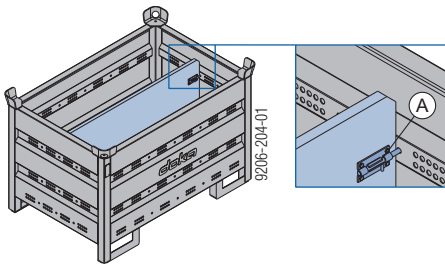

A Slide-bolt for fixing the partition

Possible ways of dividing the box

Multi-trip transport box partition	in the longitudinal direction	in the transverse direction
1.20m	max. 3 partitions	-
0.80m	-	max. 3 partitions

9206-204-02

9206-204-03

Doka multi-trip transport box 1.20x0.80mx0.41m

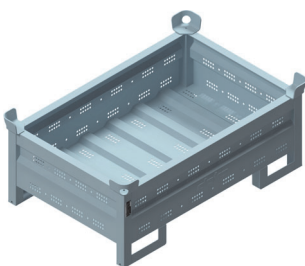

NOTICE

- Stacked multi-trip boxes or pallets must have the heaviest boxes at the bottom and the lightest at the top!
- Castor wheels must not be fitted to the bottom multi-trip packaging in the stack.
- Secure multi-trip packagings with installed castor wheels using the fixing brake when parking.

Using Doka multi-trip transport boxes as transport devices

Suitable transport appliances:

- Crane
- Forklift truck
- Pallet truck
- [Universal castor wheel for transport pallet](#)

Lifting by crane



NOTICE

- Multi-trip packaging items must be lifted individually.
- Use suitable lifting chains:
 - e.g. Doka 4-part chain 3.20m
 - Do not exceed the permitted working load limit of the lifting chains.
- Sling angle β max. 30°!

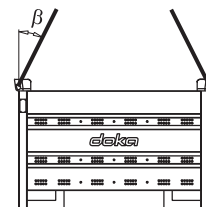

9206-202-01

Repositioning by forklift truck or pallet stacking truck

The forks can be inserted under either the broadside or the narrowside of the containers.

Doka stacking pallet 1.55x0.85m and 1.20x0.80m

Storage and transport device for long items.

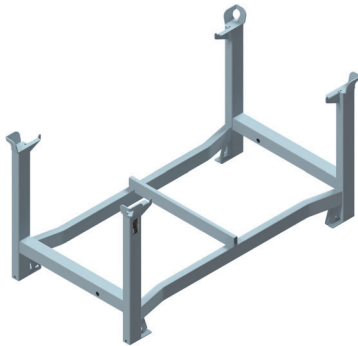

Permissible load-bearing capacity: 1100 kg (2420 lbs)
 Permissible imposed stacking load: 5900 kg (13000 lbs)

Using Doka stacking pallets as storage units

Max. number of units on top of one another

Outdoors (on the site) Floor gradients up to 3%	Indoors Floor gradients up to 1%
2	6
It is not allowed to stack empty multi-trip boxes or pallets on top of one another!	



NOTICE

- Stacked multi-trip boxes or pallets must have the heaviest boxes at the bottom and the lightest at the top!
- Castor wheels or bolt-on castor sets must not be fitted to the bottom multi-trip packaging in the stack.
- Secure multi-trip packagings with installed castor wheels using the fixing brake when parking.

Using Doka stacking pallets as transport devices

Suitable transport appliances:

- Crane
- Forklift truck
- Pallet truck
- [Universal castor wheel for transport pallet](#)
- [Bolt-on castor set B](#)

Lifting by crane



NOTICE

- Multi-trip packaging items must be lifted individually.
- Use suitable lifting chains:
 - e.g. Doka 4-part chain 3.20m
 - Do not exceed the permitted working load limit of the lifting chains.
- Load the items centrally.
- Fasten the load to the stacking pallet (e.g. with strapping tape or lashing strap) so that it cannot slide or tip out.
- Sling angle β max. 30°!

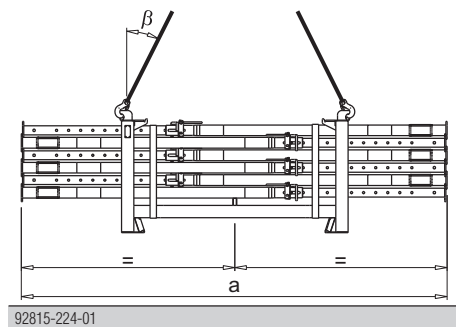

	a
Doka stacking pallet 1.55x0.85m	max. 4.5 m
Doka stacking pallet 1.20x0.80m	max. 3.0 m

Repositioning by forklift truck or pallet stacking truck



NOTICE

- Load the items centrally.
- Fasten the load to the stacking pallet (e.g. with strapping tape or lashing strap) so that it cannot slide or tip out.

Transporting Bracing frames Eurex



NOTICE

It is not allowed to mix different sizes of bracing frames!

Loading the pallet

e.g. Bracing frame Eurex 1.22m

- Turn the prop-holders (= the quick-fixing mechanisms) by 90°, fix them and place the frame into the Doka stacking pallet (see Close-up C).

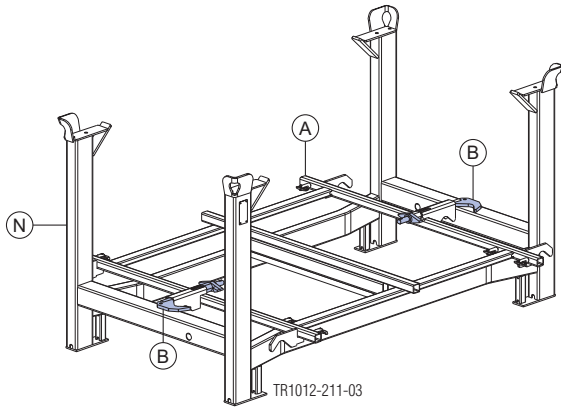

- A Bracing frame Eurex
- B Prop-holder (= quick-fixing mechanism)
- N Doka stacking pallet 1.55x0.85m

Close-up C

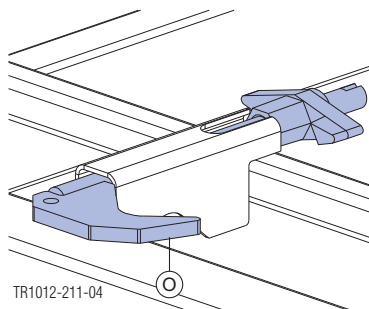

- O Prop-holder (= quick-fixing mechanism)

- Stack the other bracing frames alternate ways round (as shown in Close-up D).

- Fasten the load to the stacking pallet so that it cannot slide or tip out.

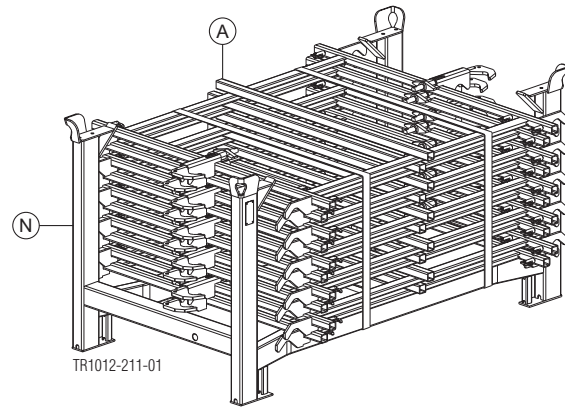

- A Bracing frame Eurex
- N Doka stacking pallet 1.55x0.85m

Close-up D

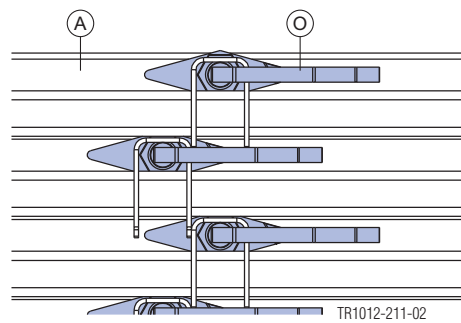

- O Prop-holder (= quick-fixing mechanism)

Load quantities

Bracing frame Eurex	Doka stacking pallet	Units
1.22m	1.55x0.85m	10
0.81m	1.20x0.80m	



Follow the directions in the 'Bolt-on castor set B' User Information booklet!

Animation:

<https://player.vimeo.com/video/262344460>

Doka accessory box

Storage and transport device for small items.

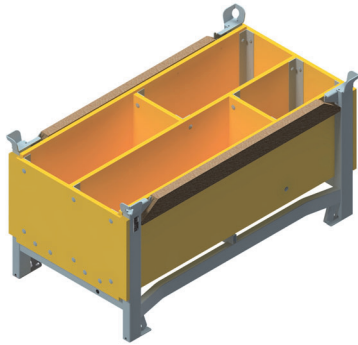

Permissible load-bearing capacity: 1000 kg (2200 lbs)
 Permissible imposed stacking load: 5530 kg (12190 lbs)

Doka accessory boxes as storage units

Max. number of units on top of one another

Outdoors (on the site) Floor gradients up to 3%	Indoors Floor gradients up to 1%
3	6
It is not allowed to stack empty multi-trip boxes or pallets on top of one another!	



NOTICE

- Stacked multi-trip boxes or pallets must have the heaviest boxes at the bottom and the lightest at the top!
- Castor wheels or bolt-on castor sets must not be fitted to the bottom multi-trip packaging in the stack.
- Secure multi-trip packagings with installed castor wheels using the fixing brake when parking.

Doka accessory box as transport devices

Suitable transport appliances:

- Crane
- Forklift truck
- Pallet truck
- [Universal castor wheel for transport pallet](#)
- [Bolt-on castor set B](#)

Lifting by crane



NOTICE

- Multi-trip packaging items must be lifted individually.
- Use suitable lifting chains:
 - e.g. Doka 4-part chain 3.20m
 - Do not exceed the permitted working load limit of the lifting chains.
- When lifting units to which Bolt-on castor sets B have been attached, you must also follow the directions in the 'Bolt-on castor set B' User information booklet!
- Sling angle β max. 30°!

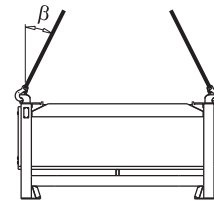

92816-206-01

Repositioning by forklift truck or pallet stacking truck

The forks can be inserted under either the broadside or the narrowside of the containers.

Universal castor wheel for transport pallet

The Universal castor wheel for transport pallet turns multi-trip packaging items into fast and manoeuvrable transport devices.

- 4 castor wheels needed per multi-trip packaging item.
- Compatible multi-trip packaging items:
 - Doka stacking pallets (all sizes)
 - Doka accessory box
 - Doka multi-trip transport box 1.20x0.80m
 - Doka skeleton transport box 1.70x0.80m
 - DokaXdek panel pallets (all sizes)
 - Dokadek infill beam pallet
 - Superdek beam pallet 1.22x1.10m



Follow the directions in the 'Universal castor wheel for transport pallet' User Information booklet.

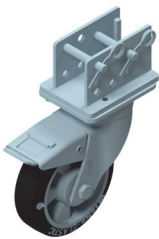

Bolt-on castor set B

The Bolt-on castor set B turns multi-trip packaging items into fast and manoeuvrable transport devices.

- Suitable for drive-through access openings > 90 cm.
- Compatible multi-trip packaging items:
 - Doka stacking pallets (all sizes)
 - Doka accessory box
 - Dokadek infill beam pallet
 - Protective barrier Z pallet (all sizes)



Follow the directions in the 'Bolt-on castor set B' User Information booklet!

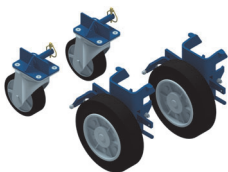

Cleaning and care of your equipment

The **special coating on the Xlife sheet** greatly reduces the amount of cleaning that is needed.



WARNING

► Risk of slippage when surface is wet!

Cleaning



NOTICE

- Immediately after pouring:
 - Remove any blobs of concrete from the back-face of the formwork, using water (without any added sand).
- Immediately after stripping the formwork
 - Clean the formwork with a high-pressure washer and a concrete scraper.
- Do not use any chemical cleaning agents!

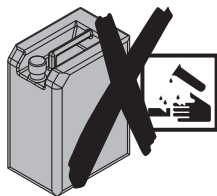

Cleaning equipment

High-pressure spray cleaner



NOTICE

- Appliance pressure rating: 200 to max. 300 bar
- Keep the water-jet the correct distance from the formwork, and move it at the right speed:
 - The higher the pressure, the further away from the formwork you must keep the jet and the faster you must move it across the surface.
- Do not aim the jet at one place for too long.
- Make only moderate use of the jet around the silicone sealing strip:
 - If the pressure is too high, this will damage the silicone sealing strip.
 - Do not aim the jet at one place for too long.

Concrete scraper

For removing any concrete remnants, we recommend using a **Double scraper Xlife** and a spatula.

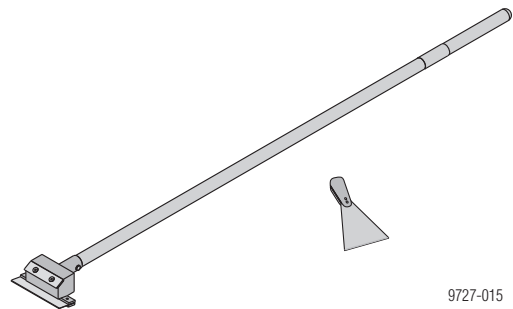

9727-015

Functional description:

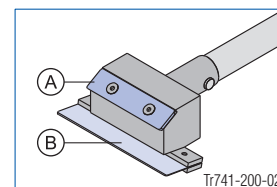

Tr741-200-02

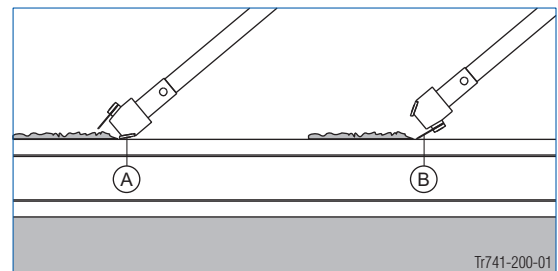

Tr741-200-01

A Blade for dealing with heavy soiling

B Blade for dealing with slight soiling



NOTICE

Do not use pointed or sharp objects, wire brushes, abrasive disks or cup brushes.

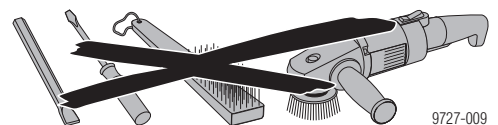

9727-009

Release agents

Doka-Trenn and Doka-OptiX are applied using the Doka sprayer for release agent.



Follow the directions in the 'Doka sprayer for release agent' Operating Instructions and on the containers of release agent.



NOTICE

- Before every pour:
 - Apply release agent to the formwork sheet and the end faces **extremely thinly, evenly** and **in a continuous layer**.
- Make sure there are no drips of release agent running down the formwork sheet.
- Applying too much release agent will spoil the concrete finish.



To determine the right dosage and to make sure that you are using the agent correctly, test it on less important parts of the structure first.

Care

- No hammer-blows to the frame profiles

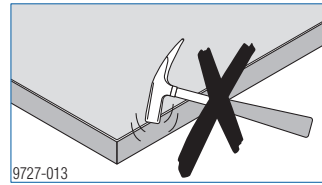

- Do not use nails on the formwork that are longer than 60 mm

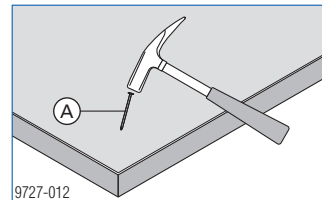

A max. l=60 mm

- Never push over panels or allow them to fall
- Do not use the panels as a climbing aid.



Reshoring props, concrete technology and stripping out



Follow the directions in the 'Stripping formwork from slabs in building construction' Calculation Guide or contact Doka!

Concrete monitoring



Concremote provides reliable, standards-compliant information on the strength development of concrete on the site, in real-time.



Follow the directions in the 'Concremote' User Information booklet.

When is the best time to strip out the formwork?

The concrete strength needed before the formwork can be stripped out will depend upon the load factor α . This can be read off from the following table.

Load factor α

This is calculated by:

$$\alpha = \frac{DL_{\text{concrete}} + LL_{\text{construction state}}}{DL_{\text{concrete}} + DL_{\text{finishing}} + LL_{\text{final state}}}$$

Slab thickness d [m]	Dead load DL_{concrete} [kN/m ²]	Load factor α $LL_{\text{final state}}$			
		2.00 kN/m ²	3.00 kN/m ²	4.00 kN/m ²	5.00 kN/m ²
0.14	3.50	0.67	0.59	0.53	0.48
0.16	4.00	0.69	0.61	0.55	0.50
0.18	4.50	0.71	0.63	0.57	0.52
0.20	5.00	0.72	0.65	0.59	0.54
0.22	5.50	0.74	0.67	0.61	0.56
0.25	6.25	0.76	0.69	0.63	0.58
0.30	7.50	0.78	0.72	0.67	0.62
0.35	8.75	0.80	0.75	0.69	0.65

Valid for a finishing load $DL_{\text{finishing}} = 2.00 \text{ kN/m}^2$ and a live load in the early-stripped state of $LL_{\text{construction state}} = 1.50 \text{ kN/m}^2$

DL_{concrete} : calculated with $\gamma_{\text{concrete}} = 25 \text{ kN/m}^3$

$DL_{\text{finishing}}$: load for floor finish, etc.

Example: Slab thickness 0.20 m with a final live load of 5.00 kN/m² results in a load factor α of 0.54.

This means that formwork removal / stress-release can take place once the concrete has reached 54% of its 28-day strength. The load-bearing capacity will then correspond to that of the finished structure.



NOTICE

If the floor props are not stress-relieved, meaning that the slab has not been activated, then the props will remain loaded with the dead weight of the floor-slab.

When the floor above is concreted, this may lead to a doubling of the load that is being applied to the floor props.

The floor props are not designed to cope with such an overload, and the result may be damage to the formwork, the floor props and the structure.

Why put up reshoring props after stripping out the formwork?

After the formwork has been stripped and the floor-slab has been stress-relieved or dismantled, the floor-slab is able to bear its dead load and live loads resulting from the construction state, but not the concreting loads from subsequent floor-slabs.

The temporary reshoring serves to support the floor-slab and distribute the concreting loads across several floors.

Positioning the reshoring props correctly

Reshoring props have the job of spreading loads between the new floor-slab and the floor beneath it. The load distribution will depend on the relationship between these two floor-slabs and their rigidity.



NOTICE

Ask an expert!

As a rule, the question of using reshoring props should be referred to the responsible experts (e.g. structural engineers), regardless of the information given above.

Observe all local standards and regulations!



The **Floor prop spring clamp** provides extra stability of the floor prop.

- This accessory reduces the risk of the floor prop tipping over when the load on it is relieved in the course of construction work.



- ▶ The spring clamp is designed to be pushed into the top end of the inner tube of the floor prop.

Strength development in the new concrete

Rough reference values can be found in DIN 1045-3:2008, Table 2. The length of time until 50 percent of the final (28-day) strength is reached can be read off from this Table as a function of the temperature and the type of concrete.

The values are only valid if the concrete is given correct, appropriate curing throughout the entire period.

For a concrete with medium strength development, the following inferred graph may thus be used.

Concrete-strength development – medium

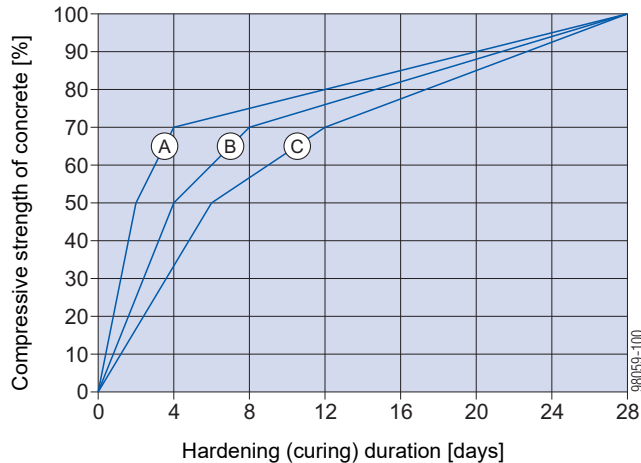

A $\vartheta \geq 15^\circ$

B $\vartheta \geq 10^\circ$

C $\vartheta \geq 5^\circ$

Deflection of the new concrete

The concrete's modulus of elasticity develops faster than compressive strength. At 60 % of its compressive strength f_{ck} , the concrete has already reached approximately 90% of its modulus of elasticity $E_{c(28)}$.

The increase in the elastic deformation taking place in the new concrete is thus only negligible.

The creep deformation, which only finally ceases after several years, is several times more than the elastic deformation.

Early striking – e.g. after 3 days instead of 28 – thus only leads to an increase in the total deformation of less than 5%.

The part of this deformation accounted for by creep deformation, however, may be anything between 50% and 100% of the standard value, due to such variable influences as the strength of the aggregates, and the atmospheric humidity. This means that the total deflection of the floor-slab is practically independent of the time at which the formwork was struck.

Cracks in new concrete

The bonding strength between the reinforcement steel and the concrete develops more rapidly in the new concrete than does its compressive strength. This means that early stripping does not have any negative influence upon the size and distribution of cracks on the tension side of reinforced concrete constructions.

Other cracking phenomena can be countered effectively by appropriate curing methods.

Curing of new concrete

New site-placed concrete is exposed to influences which may cause cracking and slow down its strength development:

- premature drying
- over-rapid cooling in the first few days
- excessively low temperatures or frost
- mechanical damage to the surface of the concrete
- hydration heat
- etc.

The simplest precaution is to leave the formwork on the concrete surface for longer. As well as the familiar extra curing measures, this measure should be carried out in any case.

Removing the load from the formwork from wide-spanned floor-slabs with support centres of over 7.5m

In the case of thin, wide-spanned concrete slabs (e.g. in multistorey car parks), the following points must be remembered:

- When the formwork beneath these slab spans is released (i.e. when the load is taken off the floor props), the floor props that are still in place are briefly subjected to additional loads. This may lead to overloading, and to the floor props being damaged.
- Please consult Doka.



NOTICE

As a general rule:

- Stress-release should always be carried out working **from one side towards the other, or from the middle of the slab (mid-span) towards the slab edges**.

For wide spans, this procedure **MUST** be followed!

- Stress-release must **NEVER** be carried out **from both sides towards the middle!**

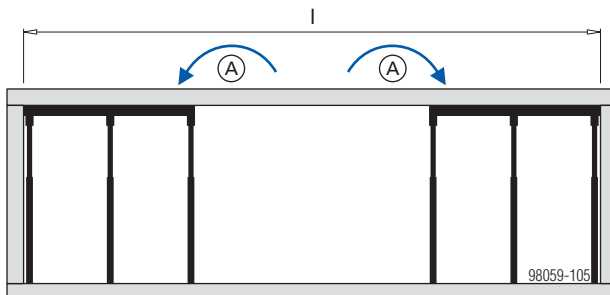
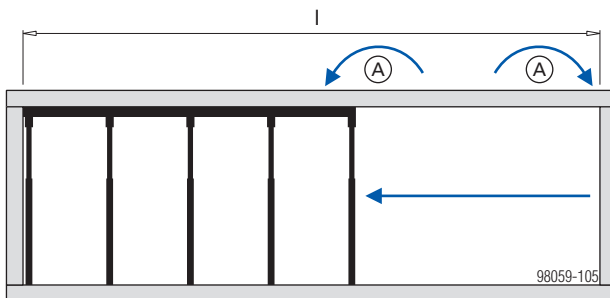

l ... effective floor-slab spans of 7.50 m and over

A Load redistribution

Horizontal loads of floor formwork

Horizontal loads imposed while the concrete is being poured are considerably higher than the horizontal loads imposed during installation. Consequently appropriate measures are required to transfer them, for example:

- into the building structure (columns or walls).
- by cables, straps, plumbing struts or bracings.

The load-bearing capacities of these measures may be combined and added.



NOTICE

- The forces occur in all directions.
- As regards the transmission of the horizontal loads into an existing structure, it can be assumed that structural components which carry horizontal loads in the final state can do so also during pouring of the concrete floor-slab, for example high-rise building core or solid reinforced-concrete columns. Slender columns hinged at both ends at the edges of structures are not suitable. Contact the structural designer if questions arise!
- The floor-slab loads are a uniformly distributed load, The horizontal loads are exerted over a large area.
If the horizontal loads are transmitted in concentrated form, it is important to form a non-positive locked formwork plane (friction, pressure contact, form-fit, pull nails, etc.).
- Particularly during assembly, storage areas on the floor formwork have to be considered separately on account of the concentrated higher loads! Additional precautions are needed here!
- When diagonal bracing is used to sustain horizontal loads, the vertical component has to be taken into account as an additional load on the floor props. Pay attention to the lifting forces at the supports.

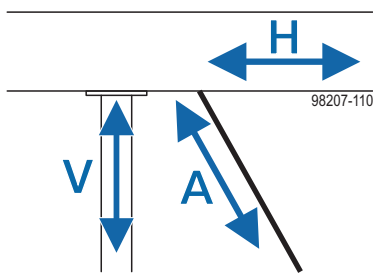

Note:

This section deals only with the typical zone for horizontal floor formwork. Special areas (edge, drop beams, steps, sloping slabs, etc.) have to be examined and planned separately!

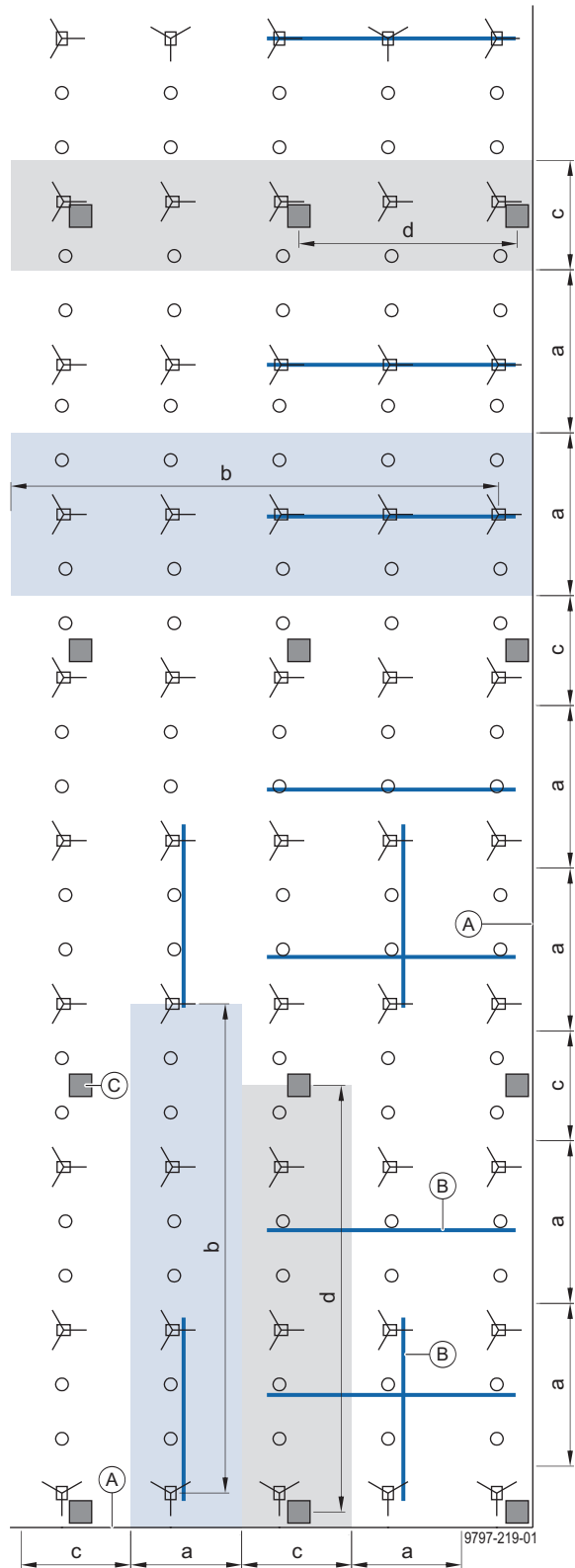

- Area of influence of the bracing
 - a influence width of the bracing
 - b spacing of the bracing in primary-beam or secondary-beam direction
- Area of influence of the existing column
 - c influence width of an existing column
 - d distance between columns
- A Slab edge (open)
- B Bracing or tie-back
- C Existing column

The following table helps to determine the area of influence of bracing, tie-back or column:

Horizontal loads [kN]



Slab thickness [cm]	Slab surface [m ²]									
	5	10	15	20	25	30	35	40	45	50
10	0.6	1.1	1.5	2.0	2.4	2.8	3.3	3.7	4.2	4.6
12	0.6	1.2	1.7	2.2	2.7	3.2	3.7	4.2	4.7	5.2
14	0.7	1.3	1.9	2.5	3.0	3.6	4.1	4.7	5.3	5.8
16	0.8	1.5	2.1	2.7	3.3	3.9	4.6	5.2	5.8	—
18	0.8	1.6	2.3	3.0	3.6	4.3	5.0	5.7	—	—
20	0.9	1.7	2.5	3.2	3.9	4.7	5.4	—	—	—
22	0.9	1.8	2.6	3.4	4.2	5.1	5.9	—	—	—
24	1.0	2.0	2.8	3.7	4.6	5.4	—	—	—	—
26	1.1	2.1	3.0	3.9	4.9	5.8	—	—	—	—
28	1.1	2.2	3.2	4.2	5.2	—	—	—	—	—
30	1.2	2.3	3.4	4.4	5.5	—	—	—	—	—
32	1.3	2.5	3.6	4.7	5.8	—	—	—	—	—
34	1.3	2.6	3.8	4.9	—	—	—	—	—	—
36	1.4	2.7	4.0	5.2	—	—	—	—	—	—
38	1.5	2.9	4.1	5.4	—	—	—	—	—	—
40	1.5	3.0	4.3	5.7	—	—	—	—	—	—
42	1.6	3.1	4.5	—	—	—	—	—	—	—
44	1.7	3.3	4.7	—	—	—	—	—	—	—
46	1.7	3.4	4.9	—	—	—	—	—	—	—
48	1.8	3.5	5.1	—	—	—	—	—	—	—
50	1.9	3.7	5.3	—	—	—	—	—	—	—
52	1.9	3.8	5.5	—	—	—	—	—	—	—
54	2.0	3.9	5.7	—	—	—	—	—	—	—
56	2.1	4.1	5.9	—	—	—	—	—	—	—







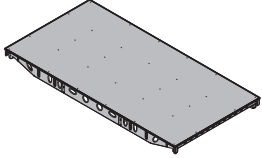

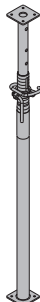
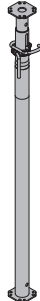
Notes on utilisation for the table:

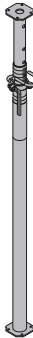
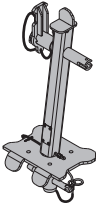

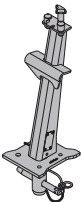

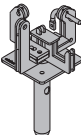
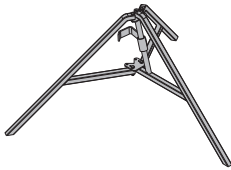
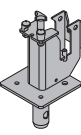
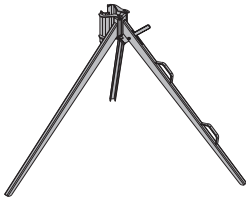

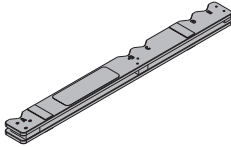
- Assumption: Horizontal load of 2.5%, comprising the following:
 - 1 % for imperfections
 - 1% for horizontal equivalent load
 - 0.5% for wind load
- The horizontal loads occur in all directions.
- All horizontal loads are less than 6 kN. It can be assumed that these loads can be absorbed by friction at a load-bearing structural column.
- The horizontal loads with blue background are less than 2.5 kN and can be transferred by Doka tie-back solutions. A permissible tie-back force of max. 5 kN at an angle of 60° is assumed.

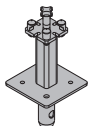
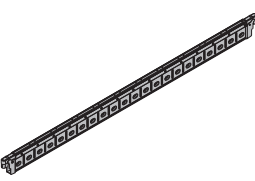

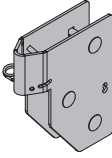
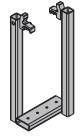
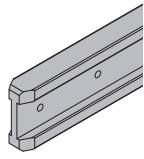
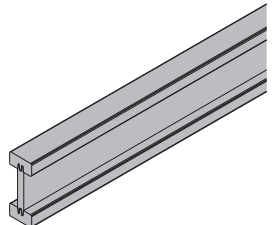
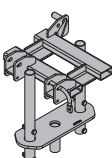
Example: Slab thickness 30 cm and bracing with lashing straps

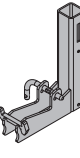
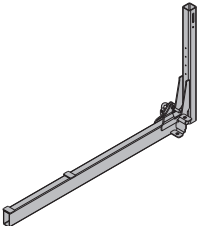
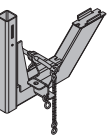
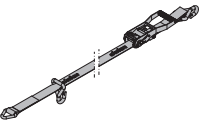
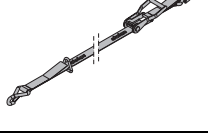

- 1 lashing strap required per 10 m² of slab area.
- If the horizontal load can be absorbed by columns for this slab thickness, each column takes up 25 m². This means that, on average, 2.5 times fewer lashing straps are required.

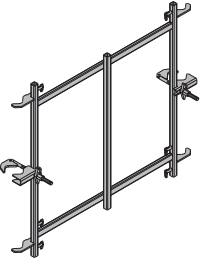
	[kg]	Article N°		[kg]	Article N°		
Dokadek panel 1.22x2.44m	49.9	586501000	 <p>Galvanised Painted yellow</p>	Doka floor prop Eurex 20 top 250	11.8	586086400	
Dokadek panel 0.81x2.44m	40.1	586502000		Length: 148 - 250 cm	Doka floor prop Eurex 20 top 300	14.3	586087400
Dokadek panel 1.22x1.22m	27.0	586566000		Doka floor prop Eurex 20 top 350	17.4	586088400	
Dokadek panel 0.81x1.22m	22.0	586567000		Length: 198 - 350 cm	Doka floor prop Eurex 20 top 400	21.6	586089400
Dokadek-Element				Length: 223 - 400 cm	32.3	586090400	
				Doka floor prop Eurex 20 top 550	48.0	586139000	
				Length: 298 - 550 cm			
				Doka floor prop Eurex 20 top 700			
				Length: 383 - 700 cm			
				Doka-Deckenstütze Eurex 20 top			
				Galvanised			
Doka floor prop Eurex 30 top 250	12.8	586092400	 <p>Galvanised</p>	Doka floor prop Eurex 20 eco 250	11.5	586270000	
Length: 148 - 250 cm				Length: 148 - 250 cm	Doka floor prop Eurex 20 eco 300	14.0	586271000
Doka floor prop Eurex 30 top 300	16.4	586093400		Length: 173 - 300 cm	Doka floor prop Eurex 20 eco 350	16.9	586272000
Length: 173 - 300 cm				Length: 198 - 350 cm	Doka floor prop Eurex 20 eco 400	21.8	586273000
Doka floor prop Eurex 30 top 350	20.7	586094400		Length: 223 - 400 cm	Doka floor prop Eurex 20 eco 450	24.1	586275000
Length: 198 - 350 cm				Length: 248 - 450 cm	Doka floor prop Eurex 20 eco 550	32.0	586276000
Doka floor prop Eurex 30 top 400	24.6	586095400		Length: 298 - 550 cm	Doka-Deckenstütze Eurex 20 eco		
Length: 223 - 400 cm			Galvanised				
Doka floor prop Eurex 30 top 450	29.1	586119400			Doka floor prop Eurex 20 basic 250	11.1	586230000
Length: 248 - 450 cm					Length: 148 - 250 cm	12.3	586277000
Doka floor prop Eurex 30 top 550	38.6	586129000			Doka floor prop Eurex 20 basic 300	14.7	586278000
Length: 303 - 550 cm					Length: 173 - 300 cm	19.9	586279000
Doka-Deckenstütze Eurex 30 top					Doka floor prop Eurex 20 basic 350		
					Length: 198 - 350 cm		
				Doka floor prop Eurex 20 basic 400			
				Length: 223 - 400 cm			
				Doka-Deckenstütze Eurex 20 basic			
				Galvanised			
							

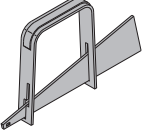
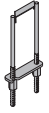
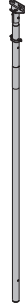
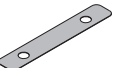
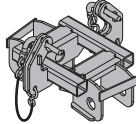
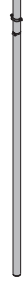
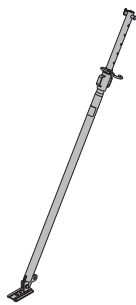

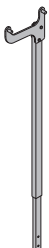
	[kg]	Article N°		[kg]	Article N°
Doka floor prop Eurex 20 LW 300 Length: 173 - 300 cm Doka floor prop Eurex 20 LW 350 Length: 198 - 350 cm Doka-Deckenstütze Eurex 20 LW Galvanised	11.5	586876000			
Dokadek corner head Dokadek-Eckkopf Galvanised Height: 54 cm	5.6	586539000			
Removable folding tripod top Stützbein top Galvanised Height: 80 cm Delivery condition: folded closed	12.0	586155500			
Dokadek wall head Dokadek-Wandkopf Galvanised Height: 56 cm	4.3	586536000			
Removable folding tripod Stützbein Galvanised Height: 80 cm Delivery condition: folded closed	15.6	586155000			
Dokadek edge head 18mm Dokadek edge head 21mm Dokadek edge head 27mm Dokadek-Randkopf Galvanised Height: 36 cm	4.0 3.9 3.8	586544000 586545000 586546000			
Removable folding tripod eco Stützbein eco Galvanised Height: 67.5 cm Delivery condition: folded closed	8.1	586294000			
Dokadek cross head Dokadek-Kreuzkopf Galvanised Height: 32 cm	2.6	586543000			
Removable folding tripod 1.20m Stützbein 1,20m Galvanised Height: 120 cm Delivery condition: folded closed	20.7	586145000			
Spring locked connecting pin 16mm Federbolzen 16mm Galvanised Length: 15 cm	0.25	582528000			
Dokadek wall clamp Dokadek-Wandhalter Dark brown Length: 138 cm	4.5	183063000			
Floor prop spring clamp Federklammer Deckenstütze Powder-coated	0.08	586169000			
Dokadek support head Dokadek-Auflagerkopf Galvanised Height: 33 cm	2.4	586506000			
Dokadek infill beam 2.44m 18mm Dokadek infill beam 1.22m 18mm Dokadek infill beam 0.81m 18mm Dokadek infill beam 2.44m 21mm Dokadek infill beam 1.22m 21mm Dokadek infill beam 0.81m 21mm Dokadek infill beam 2.44m 27mm Dokadek infill beam 1.22m 27mm Dokadek infill beam 0.81m 27mm Dokadek-Ausgleichsträger Galvanised	16.9 8.7 6.0 16.6 8.5 6.0 16.7 8.6 5.7	586509000 586510000 586511000 586512000 586513000 586514000 586515000 586516000 586517000			

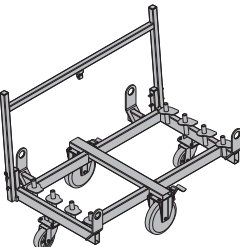
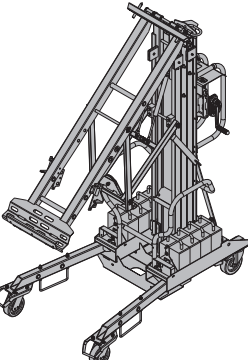
	[kg]	Article N°		[kg]	Article N°
Dokadek infill-beam shoe 18mm Dokadek infill-beam shoe 21mm Dokadek-Ausgleichsträgerschuh  Galvanised Height: 20 cm	1.7	586568000			
	1.8	586569000			
Dokadek suspension clamp H20 Dokadek-Einhängebügel H20  Galvanised Width: 15 cm Height: 35 cm	1.6	586518000			
Dokadek system beam H20 eco P 1.10m Dokadek-Systemträger H20 eco P 1,10m  Varnished yellow	5.8	189959000			
Doka beam H20 eco P 1.10m Doka-Träger H20 eco P 1,10m  Varnished yellow	5.8	189958000			
Dokadek timber beam seat H20 Dokadek-Trägeraufnahme H20  Galvanised Height: 35 cm	5.8	586550000			
Dokadek handrail-post shoe short Dokadek-Stirngeländerschuh  Galvanised Length: 23 cm Height: 56 cm	4.3	586519000			
Dokadek handrail-post shoe short 1.20m Dokadek-Stirngeländerschuh 1,20m  Galvanised Length: 23 cm Height: 27 cm	3.0	586598000			
Dokadek handrail-post shoe long Dokadek-Längsgeländerschuh  Galvanised Length: 125 cm Height: 66 cm	10.1	586520000			
Dokadek handrail-post shoe long 1.20m Dokadek-Längsgeländerschuh 1,20m  Galvanised Length: 47 cm Height: 37 cm	5.7	586560000			
Lashing strap 5.00m 2G Zurrgurt 5,00m 2G  Yellow	2.9	586018500			
Lashing strap 5.00m Zurrgurt 5,00m  Yellow	2.8	586018000			
Doka express anchor 16x125mm Doka-Expressanker 16x125mm  Galvanised Length: 18 cm	0.31	588631000			
Doka coil 16mm Doka-Coil 16mm  Galvanised Diameter: 1.6 cm	0.009	588633000			
Scaffold tube 48.3mm 0.50m Gerüstrohr 48,3mm 0,50m  Galvanised	1.7	682026000			
Bracing frame Eurex 1.22m Bracing frame Eurex 0.81m Aufstellrahmen  Galvanised Height: 111 cm	16.0	586557000			
	14.5	586558000			

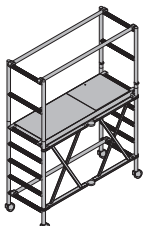
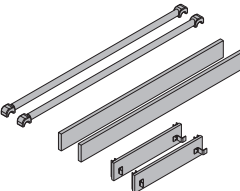
	[kg]	Article N°		[kg]	Article N°
Diagonal cross 9.175 Diagonal cross 12.100 Diagonal cross 18.200 Diagonalkreuz	6.1 4.8 7.8	582334000 582610000 582624000	 <p>Galvanised Delivery condition: folded closed</p>	Plumbing strut 540 IB Justierstütze 540 IB	30.7 588697000
Bracing clamp B Verschwertungsklammer B	1.4	586195000	 <p>Painted blue Length: 36 cm</p>	Dokadek assembling tool B Dokadek-Montagestange B	3.1 586540000
Brace stirrup 8 Spannbügel 8	2.7	582751000	 <p>Galvanised Width: 19 cm Height: 46 cm Width-across: 30 mm</p>	 <p>Aluminium Length: 215 - 387 cm</p>	
Safety plate for brace stirrup 8 Sicherungsblech für Spannbügel 8	0.05	582753000	 <p>Red Length: 23 cm</p>	Dokadek assembling tool extension 2.00m Dokadek-Montagestangenverlängerung 2,00m	1.5 586538000
Dokadek plumbing strut connector Dokadek-Justierstützenanschluss	4.1	586537000	 <p>Galvanised Length: 28.5 cm Width: 26 cm Height: 16.6 cm</p>	 <p>Aluminium</p>	
Plumbing strut 340 IB Justierstütze 340 IB	16.7	588696000	 <p>Galvanised Length: 190.8 - 341.8 cm</p>	Dokadek suspension tool Dokadek-Einhängestange	3.1 586562000
				 <p>Aluminium Head part yellow Length: 215 - 386 cm</p>	
				Dokadek stripping tool Dokadek-Ausschalwerkzeug	5.0 586541000
				 <p>Powder-coated yellow Length: 212 cm</p>	

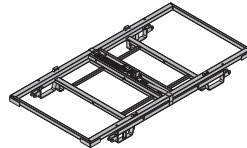
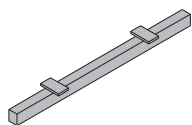
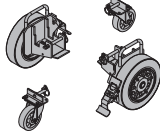
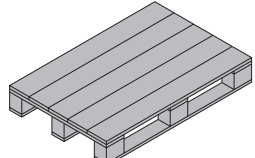
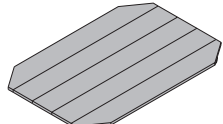
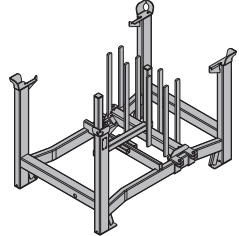
	[kg]	Article N°
Dokadek stripping tool extension 1.50m Dokadek-Ausschalwerkzeugverlängerung 1,50m Powder-coated yellow 	3.1	586559000
DekDrive DekDrive 	57.9	586526000
Galvanised Length: 145 cm Width: 88 cm Height: 108 cm Delivery condition: folded closed		
DekLift 4.50m DekLift 4,50m 	368.0	586553000
Galvanised Follow the directions in the "Operating Instructions"!		
		CE
Platform stairway 0.97m Podesttreppe 0,97m 	23.5	586555000
Aluminium Width: 121 cm Pay attention to the national, technical safety regulations!		
Wheel-around scaffold DF Mobilgerüst DF 	44.0	586157000
Aluminium Length: 185 cm Width: 80 cm Height: 255 cm Delivery condition: separate parts		
Wheel-around scaffold DF accessory set Zubehörset Mobilgerüst DF 	13.3	586164000
Aluminium Timber parts varnished yellow Length: 189 cm		

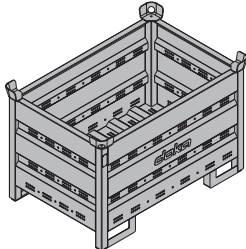
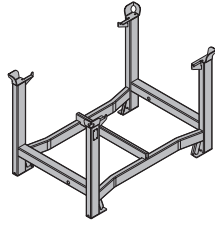
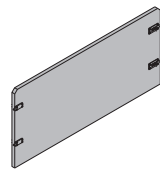
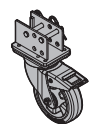
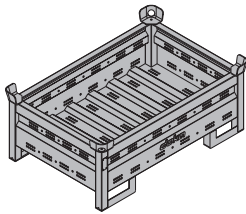
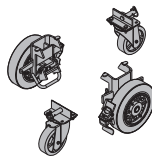
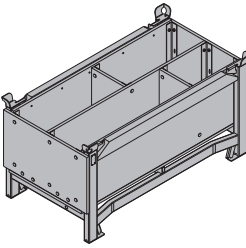
	[kg]	Article N°
Multi-trip packaging 		
Dokadek panel pallet 1.22x2.44m Dokadek-Elementpalette 1,22x2,44m Galvanised Height: 26 cm	75.0	586523000
Dokadek panel pallet 0.81x2.44m Dokadek-Elementpalette 0,81x2,44m Galvanised Height: 26 cm	66.0	586524000
Dokadek supp. timber 1.73m (HT) Dokadek-Unterlagsholz 1,73m (HT) Width: 18 cm Height: 11.8 cm	5.7	176179000
		
Attachable wheelset Aufsteck-Radsatz 	27.3	586525000
Galvanised		
Wooden pallet 1.20x0.80m (HT) Holzpalette 1,20x0,80m (HT) Height: 17.6 cm	26.5	176125000
		
Crate cover 1.20x0.80m (HT) Kistendeckel 1,20x0,80m (HT) Height: 3.6 cm	10.5	176124000
		
Dokadek infill beam pallet Dokadek-Ausgleichsträgerpalette 	62.0	586528000
Galvanised Length: 119 cm Width: 79 cm Height: 81 cm		

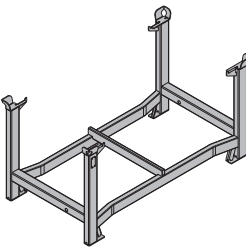
	[kg]	Article N°		[kg]	Article N°
Doka multi-trip transport box 1.20x0.80m Doka-Mehrwegcontainer 1,20x0,80m  Galvanised Height: 78 cm	70.0	583011000	Doka stacking pallet 1.20x0.80m Doka-Stapelpalette 1,20x0,80m  Galvanised Height: 77 cm	38.0	583016000
Multi-trip transport box partition 0.80m Multi-trip transport box partition 1.20m Mehrwegcontainer Unterteilung  Steel parts galvanised Timber parts varnished yellow	3.7 5.5	583018000 583017000	Universal castor wheel for transport pallet Universal-Lenkrolle Transportgebinde  Galvanised Height: 28.8 cm	6.0	584043000
Doka multi-trip transport box 1.20x0.80x0.41m Doka-Mehrwegcontainer 1,20x0,80x0,41m Galvanised 	42.5	583009000	Bolt-on castor set B Anklemm-Radsatz B  Painted blue	33.6	586168000
Doka accessory box Doka-Kleinteilebox  Timber parts varnished yellow Steel parts galvanised Length: 154 cm Width: 83 cm Height: 77 cm	106.4	583010000			
Doka skeleton transport box 1.70x0.80m Doka-Gitterbox 1,70x0,80m  Galvanised Height: 113 cm	87.0	583012000			
Doka stacking pallet 1.55x0.85m Doka-Stapelpalette 1,55x0,85m  Galvanised Height: 77 cm	41.0	586151000			



Formwork & Scaffolding.
We make it work.



www.doka.com/dokadek-30