

# Framed formwork Framax Xlife

## User Information

Instructions for assembly and use (Method statement)



9764-449-01



# Contents

<b>4</b>	<b>Introduction</b>
4	Elementary safety warnings
7	Intended use
<b>8</b>	<b>Wall formwork</b>
9	Instructions for assembly and use for room-high formwork
12	Instructions for assembly and use for high formwork
16	Framax panel in detail
18	System grid
19	Inter-panel connections
22	Panel bracing with Framax universal waling
23	Vertical stacking of panels
38	Tie rod system
42	Length adjustment using closures
45	90 degree corners
50	Acute & obtuse-angled corners
53	Shaft formwork
57	Inter-panel connections for increased tensile loads
59	Stop-end formwork
64	Wall junctions, offsets and steps
67	Window and door openings
68	Plumbing accessories
72	Pouring platforms
77	Pouring platforms with single brackets
92	Opposing guardrail
96	Wall formwork at the edge of the structure
100	Ladder system
104	Tools for plumbing and aligning and for stripping the formwork
106	Lifting by crane
109	Transporting, stacking and storing
<b>117</b>	<b>General</b>
117	Areas of use
118	Framax Xlife in conjunction with . . .
122	Cleaning and care of your equipment
124	Fall protection on the structure
<b>127</b>	<b>Article list</b>

# Introduction

## Elementary safety warnings

### User target groups

- This booklet is aimed at all persons who will be working with the Doka product or system that it describes. It contains information on the standard design for setting up this system, and on correct, compliant utilisation of the system.
- All persons working with the product described herein must be familiar with the contents of this booklet and with all the safety instructions it contains.
- Persons who are incapable of reading and understanding this booklet, or who can do so only with difficulty, must be instructed and trained by the customer.
- The customer is to ensure that the information materials provided by Doka (e.g. User Information booklets, Instructions for Assembly and Use, Operating Instruction manuals, plans etc.) are up to date and available to all users, and that they have been made aware of them and have easy access to them at the usage location.
- In the relevant technical documentation and formwork utilisation plans, Doka shows the workplace safety precautions that are necessary in order to use the Doka products safely in the usage situations shown.  
In all cases, users are obliged to ensure compliance with national laws, standards and regulations throughout the entire project and to take appropriate additional or alternative workplace safety precautions where necessary.

### Hazard assessment

- The customer is responsible for drawing up, documenting, implementing and continually updating a hazard assessment at every job-site. This booklet serves as the basis for the site-specific hazard assessment, and for the instructions given to users on how to prepare and utilise the system. It does not substitute for these, however.

### Remarks on this booklet

- This document can be used as general Instructions for Assembly and Use (Method Statement) or be incorporated into site-specific Instructions for Assembly and Use (Method Statement).
- **The graphics, animations and videos in this document or app sometimes depict partially assembled assemblies and may require additional safety equipment and/or measures to comply with safety regulations.**  
The customer must ensure all applicable regulations are complied with, even if they are not shown or implied in the graphics, animations and videos provided.
- **Individual sections contain further safety instructions and/or special warnings as applicable.**

### Planning

- Provide safe workplaces for those using the formwork (e.g. for when it is being erected/dismantled, modified or repositioned etc). It must be possible to get to and from these workplaces via safe access routes!
- **If you are considering any deviation from the details and instructions given in this booklet, or any application which goes beyond those described in the booklet, then revised static calculations must be produced for checking, as well as supplementary assembly instructions.**

### Regulations; industrial safety

- All laws, Standards, industrial safety regulations and other safety rules applying to the utilisation of our products in the country and/or region in which you are operating must be observed at all times.
- If a person or object falls against, or into, the side-guard component and/or any of its accessories, the component affected may only continue in use after it has been inspected and passed by an expert.

## Rules applying during all phases of the assignment

- The customer must ensure that this product is erected and dismantled, reset and generally used for its intended purpose in accordance with the applicable laws, standards and rules, under the direction and supervision of suitably skilled persons. These persons' mental and physical capacity must not in any way be impaired by alcohol, medicines or drugs.
- Doka products are technical working appliances which are intended for industrial / commercial use only, always in accordance with the respective Doka User Information booklets or other technical documentation authored by Doka.
- The stability and load-bearing capacity of all components and units must be ensured during all phases of the construction work!
- Do not step on or apply strain to cantilevers, closures, etc. until suitable measures to ensure their stability have been correctly implemented (e.g. by tie-backs).
- Strict attention to and compliance with the functional instructions, safety instructions and load specifications are required. Non-compliance can cause accidents and severe injury (risk of fatality) and considerable damage to property.
- Sources of fire in the vicinity of the formwork are prohibited. Heaters are permissible only when used correctly and situated a correspondingly safe distance from the formwork.
- Customer must give due consideration to any and all effects of the weather on the equipment and regards both its use and storage (e.g. slippery surfaces, risk of slipping, effects of the wind, etc.) and implement appropriate precautionary measures to secure the equipment and surrounding areas and to protect workers.
- All connections must be checked at regular intervals to ensure that they are secure and in full working order.  
In particular threaded connections and wedged connections have to be checked and retightened as necessary in accordance with activity on the jobsite and especially after out-of-the-ordinary occurrences (e.g. after a storm).
- It is strictly forbidden to weld Doka products – in particular anchoring/tying components, suspension components, connector components and castings etc. – or otherwise subject them to heating.  
Welding causes serious change in the microstructure of the materials from which these components are made. This leads to a dramatic drop in the failure load, representing a very great risk to safety.  
It is permissible to cut individual tie rods to length with metal cutting discs (introduction of heat at the end of the rod only), but it is important to ensure that flying sparks do not heat and thus damage other tie rods.  
The only articles which are allowed to be welded are those for which the Doka literature expressly points out that welding is permitted.

## Assembly

- The equipment/system must be inspected by the customer before use, to ensure that it is in an acceptable condition. Steps must be taken to exclude components that are damaged, deformed, or weakened due to wear, corrosion or rot (e.g. fungal decay).
- Using our safety and formwork systems together with those of other manufacturers can create risks that may lead to injury and damage to property. This requires separate verification by the user.
- The equipment/system must be assembled and erected in accordance with the applicable laws, standards and rules by trained customer personnel whilst maintaining any applicable safety inspections that may be required.
- It is not permitted to modify Doka products; such modifications constitute a safety risk.

## Closing the formwork

- Doka products and systems must be set up so that all loads acting upon them are safely transferred!

## Pouring

- Do not exceed the permitted fresh-concrete pressures. Over-high pouring rates overload the formwork, cause greater deflection and risk breakage.

## Stripping the formwork

- Do not strip out the formwork until the concrete has reached sufficient strength and the person in charge has given the order for the formwork to be stripped out!
- When stripping out the formwork, never use the crane to break concrete cohesion. Use suitable tools such as timber wedges, special pry-bars or system features such as Framax stripping corners.
- When stripping out the formwork, do not endanger the stability of any part of the structure, or of any scaffolding, platforms or formwork that is still in place!

## Transporting, stacking and storing

- Observe all country-specific regulations applying to the handling of formwork and scaffolding. For system formwork the Doka slinging means stated in this booklet must be used – this is a mandatory requirement.

If the type of sling is not specified in this document, the customer must use slinging means that are suitable for the application envisaged and that comply with the regulations.

- When lifting, always make sure that the unit to be lifted and its individual parts can absorb the forces that occur.
- Remove loose parts or secure them so that they cannot slip out of position and drop.
- When lifting formwork or formwork accessories with a crane, no persons must be carried along, e.g. on working platforms or in multi-trip packaging.
- All components must be stored safely, following all the special Doka instructions given in the relevant sections of this document!

## Maintenance

- Only original Doka components may be used as spare parts. Repairs may only be carried out by the manufacturer or authorised facilities.

## Miscellaneous

The weights as stated are averages for new material; actual weights can differ, depending on material tolerances. Dirt accretions, moisture saturation, etc. can also affect weight.

We reserve the right to make alterations in the interests of technical progress.

## Eurocodes at Doka

**The permissible values stated in Doka documents (e.g.  $F_{perm} = 70$  kN) are not design values (e.g.  $F_{Rd} = 105$  kN), unless specified!**

- It is essential to avoid confusing permissible values with design values!
- Doka documents will continue to state the permissible values.

Allowance has been made for the following partial factors:

- $\gamma_F = 1.5$
- $\gamma_{M, timber} = 1.3$
- $\gamma_{M, steel} = 1.1$
- $k_{mod} = 0.9$

Consequently, all the design values for an EC design calculation can be determined from the permissible values.

## Symbols used

The following symbols are used in this document:



### DANGER

This is a notifier drawing attention to an extremely dangerous situation in which non-compliance with this notifier will lead to death or severe, irreversible injury.



### WARNING

This is a notifier drawing attention to a dangerous situation in which non-compliance with this notifier can lead to death or severe, irreversible injury.



### CAUTION

This is a notifier drawing attention to a dangerous situation in which non-compliance with this notifier can lead to slight, reversible injury.



### NOTICE

This is a notifier drawing attention to a situation in which non-compliance with this notifier can lead to malfunctions or damage to property.



### Instruction

Indicates that actions have to be performed by the user.



### Sight-check

Indicates that you need to do a sight-check to make sure that necessary actions have been carried out.



### Tip

Points out useful practical tips.



### Reference

Cross-references other documents.

## Intended use

The Framed formwork Framax Xlife is a formwork system for the cast-in-place concrete construction of walls, foundations, shafts and columns. The Framed formwork Framax Xlife is designed for setting up using a crane.

Boundary conditions for use:

- Max. formwork height: 8.10 m
- Max. wall thickness: 75 cm

In special cases, boundary conditions can vary. The relevant information in the Doka technical documents must be observed.

Other use or use not in conformity with that stated above is non-intended use and requires the prior written approval of the Doka company!

## Areas of use

### Wall formwork

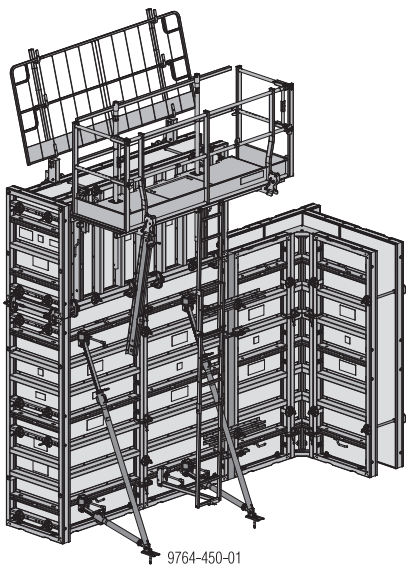

### Circular formwork

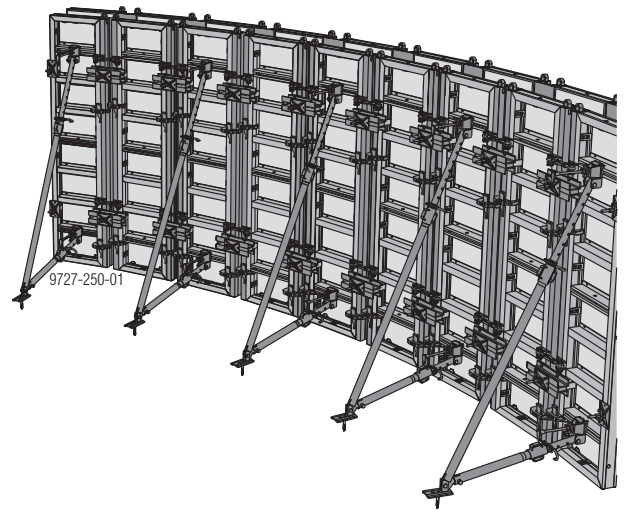

Follow the directions in the 'Circular formwork Framax Xlife' User Information booklet.

### Foundation formwork

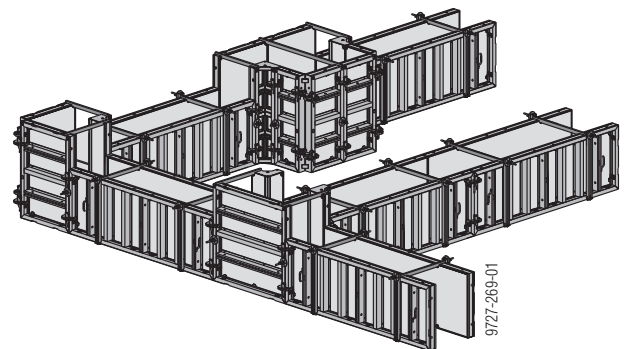

Follow the directions in the 'Foundation formwork Framax Xlife' User Information booklet.

### Column formwork

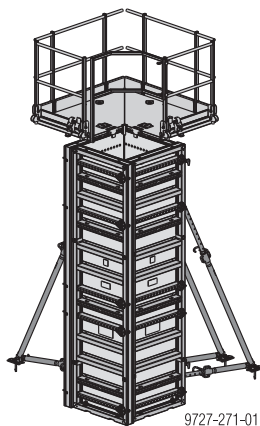

Follow the directions in the 'Column formwork Framax Xlife' User Information booklet.

# Wall formwork

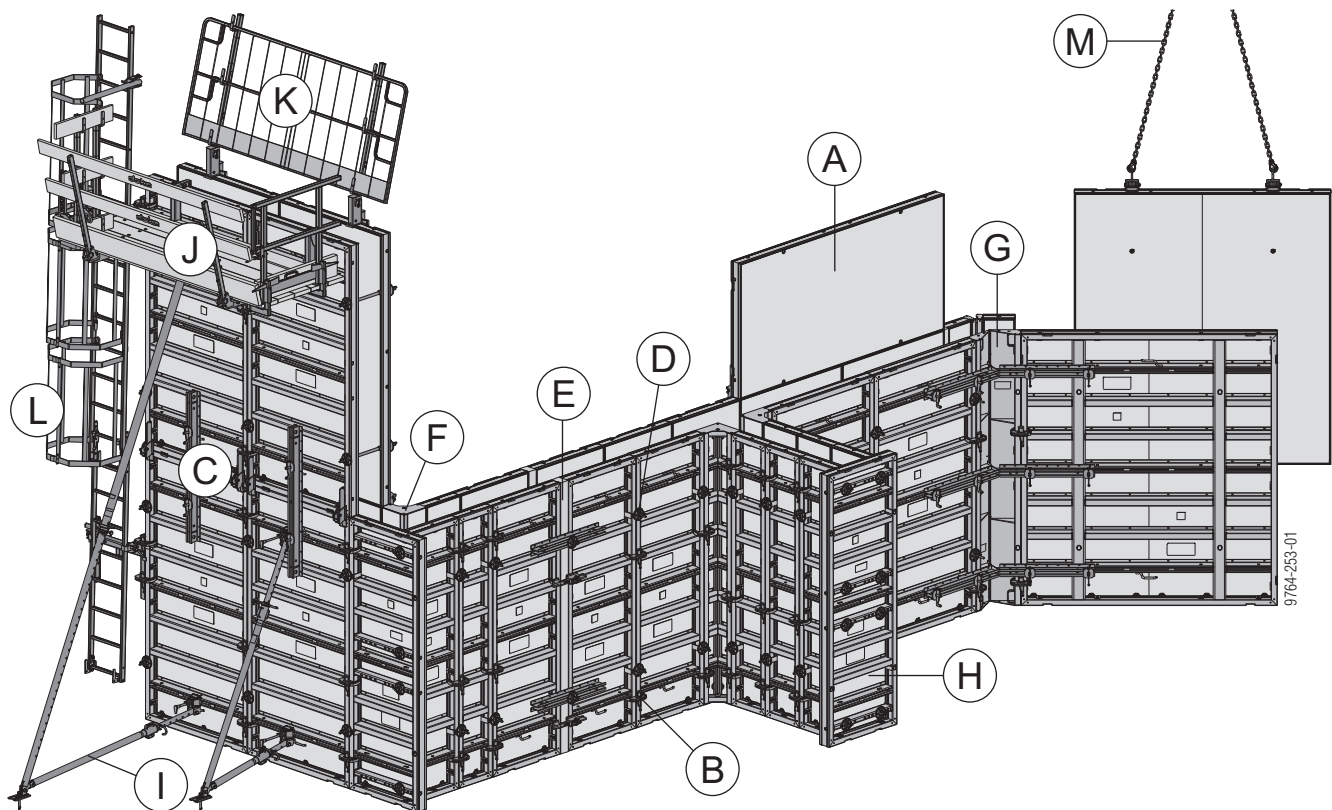

## Section:

- A [Framax panel in detail](#)
- B [Inter-panel connections](#)
- C [Vertical stacking of panels](#)
- D [Tie rod system](#)
- E [Length adjustment using closures](#)
- F [90 degree corners](#)
- G [Acute & obtuse-angled corners](#)
- H [Stop-end formwork](#)
- I [Plumbing accessories](#)
- J [Pouring platforms](#)
- K [Opposing guardrail](#)
- L [Ladder system](#)
- M [Lifting by crane](#)

## Permitted fresh-concrete pressure:

See the sections headed [Framax panel in detail](#) and [Tie rod system](#).

## Instructions for assembly and use for room-high formwork

The sequence shown here is based on a straight wall. However, you should always start to form from the corner outwards.

Ladders must be located so as to create viable 'traffic routes' in the horizontal. (On a straight wall, for example, one ladder on the first element and another on the last).

If single brackets are used instead of pouring platforms, follow the instructions in the section headed [Pouring platforms with single brackets](#).

### Transporting / handling the panels

- ▶ For offloading panels from a truck, or lifting them on-site (see the section headed [Transporting, stacking and storing](#)).
- ▶ To separate the panels, use Framax transport bolts and the Doka 4-part chain 3.20m (see the section headed [Transporting, stacking and storing](#)).

### Pre-assembly

- ▶ Pre-assemble gang-forms face-down on a prepared flat area (see the section headed [Inter-panel connections](#)).
- ▶ Mount panel struts to the gang-form while it is laid flat (see the section headed [Plumbing accessories](#)).
- ▶ Mount the Ladder system XS (see the section headed [Ladder system](#)).

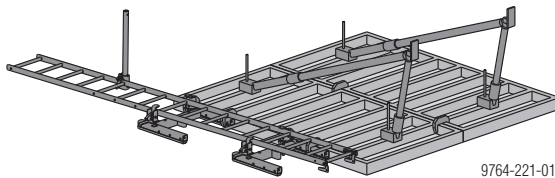

### Closing the formwork



#### NOTICE

- For working at heights that cannot be reached from the floor, use a suitable elevated platform (e.g. Platform stairway 0.97m, Wheel-around scaffold DF or mobile scaffold tower)!
- Always comply with the country-specific safety regulations!
- Do not step on to the pouring platform until an all-round guardrail system (including counter railing) is in place!  
Otherwise wear a personal fall-arrest system (e.g. safety harness)!

- ▶ Attach the gang-form to the crane with Framax lifting hooks (see the section headed [Lifting by crane](#) and the 'Framax lifting hook' Operating Instructions).

#### Permissible working load limit:

- Sling angle  $\beta$  up to 30°:  
1000 kg (2200 lbs) / Framax lifting hook
- Sling angle  $\beta$  up to 7.5°:  
1500 kg (3300 lbs) / Framax lifting hook

Framax lifting hooks with working load limit of 1000 kg (2200 lbs) max. also meet the requirements for a working load limit of 1500 kg (3300 lbs) max. using a sling angle  $\beta \leq 7.5^\circ$ .

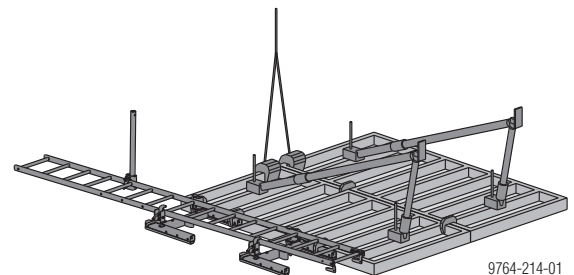

- ▶ Raise the gang-form by crane.
- ▶ Spray the formwork sheet with release agent (see the section headed [Cleaning and care of your equipment](#)).
- ▶ Lift the gang-form to its new location.



#### NOTICE

Never use a sledge hammer to plumb and align the panels!

This would damage the profiles of the gangs.

- ▶ Use only proper aligning tools (e.g. a special pry-bar) that cannot cause any damage.
- ▶ Fix the panel struts firmly to the ground (see the section headed [Plumbing accessories](#)).

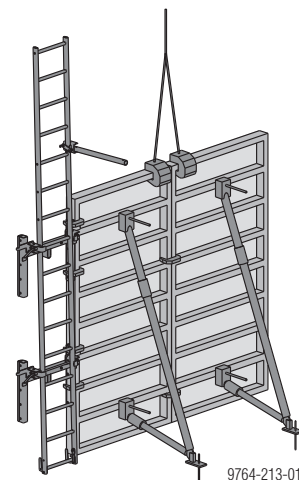

The gang-form is now stable and can be plumbed and aligned exactly, with no need for the crane.

- ▶ Use the Framax assembling tool to disengage the gang-form from the crane (see the section headed [Assembling tool](#)).

- ▶ Engage the pouring platform with pre-installed end-of-platform sideguard (see the section headed [Pouring platforms](#)).

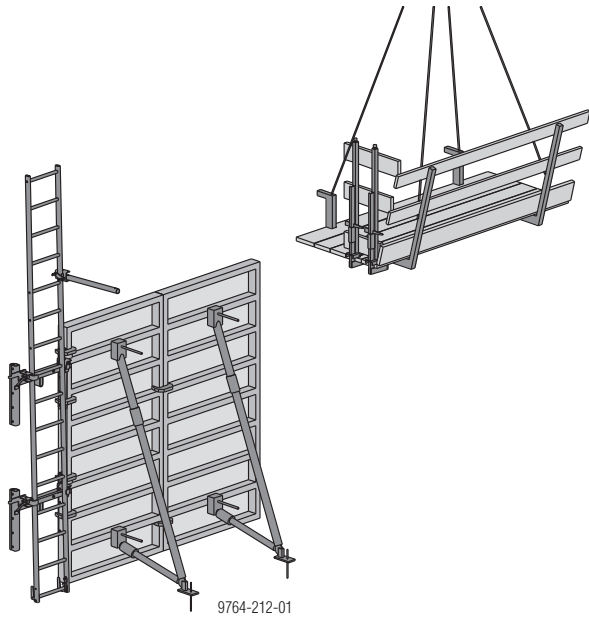

- ▶ Detach the pouring platform from the crane. The crew can reach the lifting points by standing on an elevated platform (for access, flip up the formwork-side deck-board).
- ▶ Continue lining up further gang-forms in this way, and link them together (see the section headed [Inter-panel connections](#)).

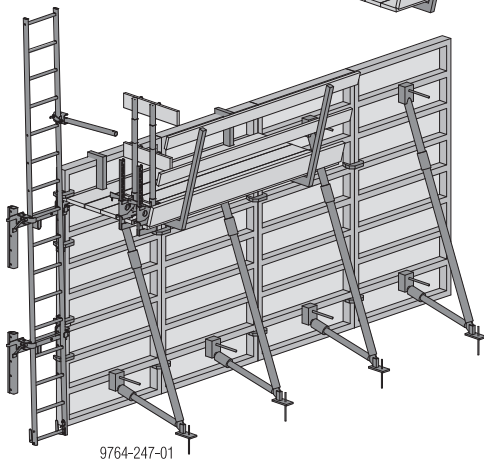
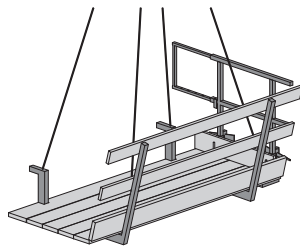

### Erecting the opposing formwork:

Once the reinforcement has been placed, the formwork can be closed.

- ▶ Mount the counter railing to the (laid-flat) gang-form of the opposing formwork (see the section headed [Opposing guardrail](#)).

- ▶ Spray the formwork sheet with release agent (see the section headed [Cleaning and care of your equipment](#)).
- ▶ Lift the opposing formwork by crane to its next location.

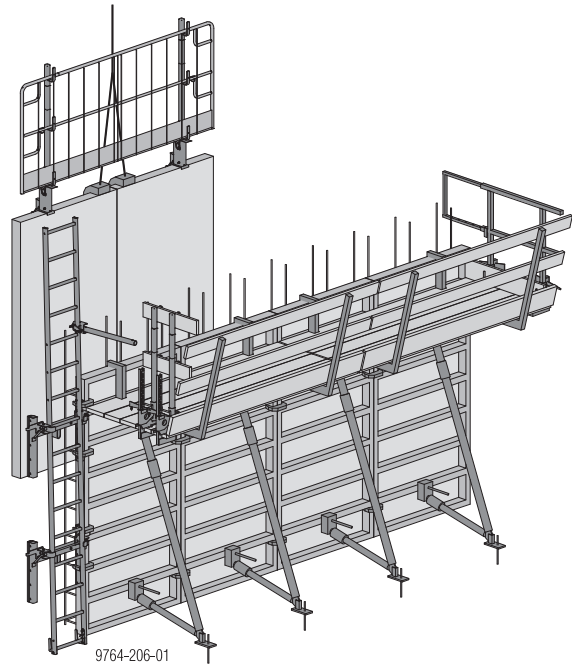

- ▶ Fit the form ties (see the section headed [Tie rod system](#)).



#### WARNING

No panel struts on the opposing formwork!  
Risk of the formwork tipping over!

- ▶ Do not disconnect the gang-form from the crane until a large enough number of form ties have been installed to keep it safely in the upright.

- ▶ Use the Framax assembling tool to disengage the gang-form from the crane (see the section headed 'Assembling tool').
- ▶ Continue lining up further gang-forms in this way, and link them together (see the section headed [Inter-panel connections](#)).

### Pouring



#### NOTICE

Do not exceed the maximum permissible rate of placing.

#### Framed formwork Framax Xlife:

Permissible fresh-concrete pressure: See sections [Framax panel in detail](#) and [Tie rod system](#).



Observe the section 'Pressure of fresh concrete on vertical formwork, DIN 18218' in the Calculation Guide 'Doka formwork engineering' or contact Doka.



Observe DIN 4235 Part 2 'Compacting of concrete by vibrating; Compacting by internal vibrators'.

- ▶ Pour the concrete.
- ▶ Make only moderate use of vibrators, carefully coordinating the times and locations of vibrator use.

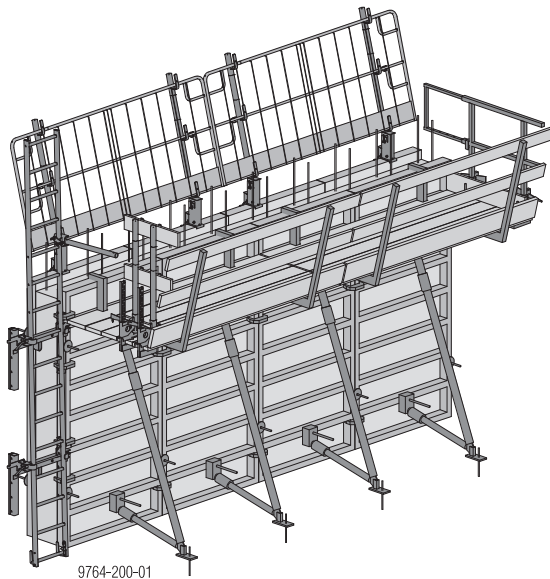

9764-200-01

## Stripping the formwork



### NOTICE

- ▶ Comply with the stipulated stripping times.
- ▶ Remove any loose items from the formwork and platforms, or secure them firmly.
- ▶ Use the Framax assembling tool to engage the gang-form on the crane (see the section headed [Assembling tool](#)).
- ▶ Take out the form ties and undo the connectors to the adjacent panels.

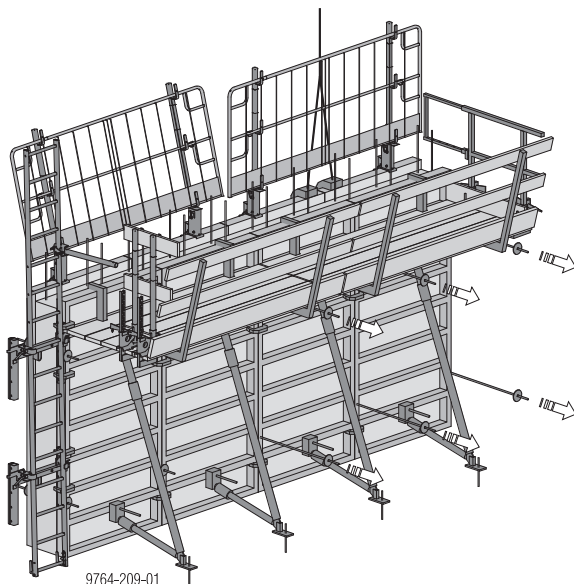

9764-209-01



In order to speed up operations when lifting and repositioning by crane, most of the form ties can be taken out in advance.

### Caution!

However, there must be at least as many form ties left in place as are needed to keep the panels safely in the upright.



### WARNING

The formwork tends to adhere to the concrete. When stripping the formwork, do not try to break concrete cohesion using the crane! Risk of crane overload.

- ▶ Use suitable tools such as timber wedges or a special pry-bar to detach the formwork from the concrete.

- ▶ Lift the gang-form away and to its next location. If the gang-form is 'parked' prior to its next use, it must have sufficient stability (see the section headed [Plumbing accessories](#)). Gang-forms with only one panel strut must not be 'parked' upright, but placed face-down.
- ▶ Clean residual concrete off the formwork sheet (see the section headed [Cleaning and care of your equipment](#)).
- ▶ Where the gang-form has panel struts and a pouring platform attached to it, first attach this gang-form to the crane, and only then detach the floor anchorages of the panel struts.

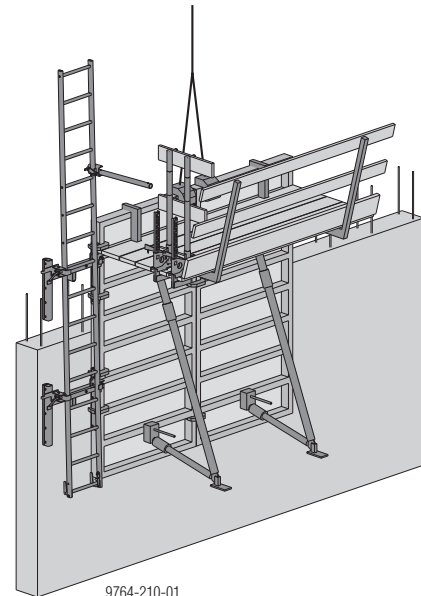

9764-210-01

## Instructions for assembly and use for high formwork

The sequence shown here is based on a straight wall. However, you should always start to form from the corner outwards.

Ladders must be located so as to create viable 'traffic routes' in the horizontal. (On a straight wall, for example, one ladder on the first element and another on the last).

### Transporting / handling the panels

- ▶ For offloading panels from a truck, or lifting them on-site (see the section headed [Transporting, stacking and storing](#)).
- ▶ To separate the panels, use Framax transport bolts and the Doka 4-part chain 3.20m (see the section headed [Transporting, stacking and storing](#)).

### Pre-assembly

- ▶ Pre-assemble gang-forms face-down on a prepared flat area (see section [Inter-panel connections](#)).
- ▶ Install the attachment point for the personal fall-arrest system (Tie-off set PPE type A<sup>\*)</sup>).

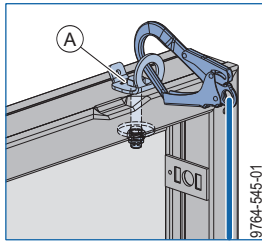

<sup>\*)</sup> tested according to EN 795 (type A)

- ▶ Mount the pouring platforms, ladder system and panel struts to the gang-form while it is laid flat (see sections [Pouring platforms with single brackets](#), [Ladder system](#) and [Plumbing accessories](#)).
- The topmost guardrail board is not installed until the gang-form is upright - secure it to the decking until then!

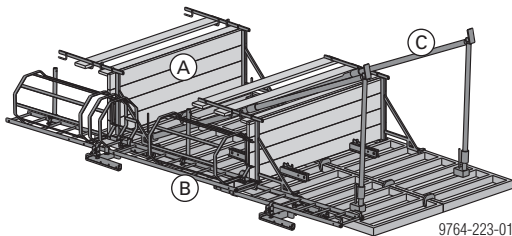

**A** Formwork platform (pouring platform)

**B** Access system

**C** Panel strut

### Closing the formwork



#### NOTICE

- For working at heights that cannot be reached from the floor, use a suitable elevated platform (e.g. Platform stairway 0.97m, Wheel-around scaffold DF, mobile scaffold tower or scissor-type elevated work platform)!
- Always comply with the country-specific safety regulations!
- Do not step on to the pouring platform until an all-round guardrail system (including counter railing) is in place! Otherwise wear a personal fall-arrest system (e.g. safety harness)!

- ▶ Attach the gang-form to the crane with Framax lifting hooks (see the section headed [Lifting by crane](#) and the 'Framax lifting hook' Operating Instructions).

#### Permissible working load limit:

- Sling angle  $\beta$  up to  $30^\circ$ :  
1000 kg (2200 lbs) / Framax lifting hook
- Sling angle  $\beta$  up to  $7.5^\circ$ :  
1500 kg (3300 lbs) / Framax lifting hook

Framax lifting hooks with working load limit of 1000 kg (2200 lbs) max. also meet the requirements for a working load limit of 1500 kg (3300 lbs) max. using a sling angle  $\beta \leq 7.5^\circ$ .

- ▶ Raise the gang-form by crane.
- ▶ Spray the formwork sheet with release agent (see the section headed [Cleaning and care of your equipment](#)).
- ▶ Lift the gang-form to its new location.



#### NOTICE

Never use a sledge hammer to plumb and align the panels!

This would damage the profiles of the gangs.

- ▶ Use only proper aligning tools (e.g. a special pry-bar) that cannot cause any damage.

- ▶ Fix the panel struts firmly to the ground (see the section headed [Plumbing accessories](#)).
- The gang-form is now stable and can be plumbed and aligned exactly, with no need for the crane.



**WARNING**

No all-round guardrail system present on the pouring platform!

Danger to life from fatal falls!

- ▶ Use a personal fall-arrest system (e.g. safety harness)
- The Tie-off set PPE type A connected to the framed formwork panel serves as attachment point.

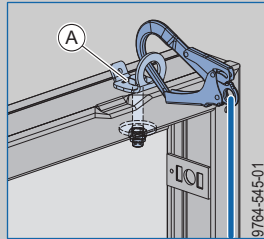

- ▶ Detach the gang-form from the crane.
- ▶ Mount the top guardrail board.

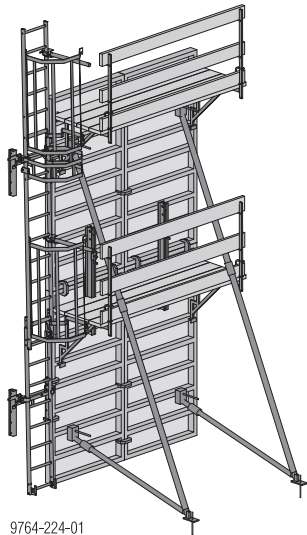

- ▶ Continue lining up further gang-forms in this way, and link them together (see the section headed [Inter-panel connections](#)).

**Erecting the opposing formwork:**

Once the reinforcement has been placed, the formwork can be closed.

- ▶ Spray the formwork sheet with release agent (see the section headed 'Cleaning and care of your equipment').

- ▶ Lift the opposing formwork by crane to its next location.

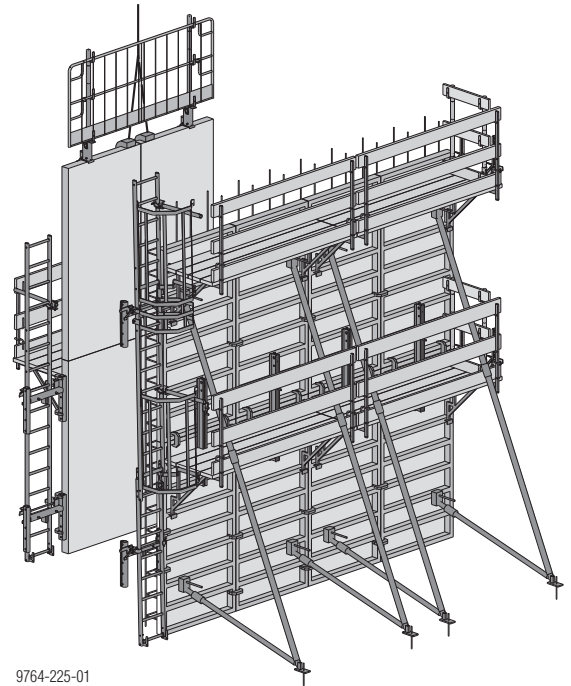

- ▶ Working from the ground, insert the bottom two rows of form ties (see 'Tie rod system').



**WARNING**

No all-round guardrail system present on the pouring platform!

Danger to life from fatal falls!

- ▶ Use a personal fall-arrest system (e.g. safety harness)
- The Tie-off set PPE type A connected to the framed formwork panel serves as attachment point.

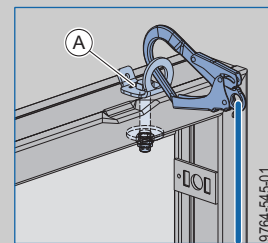

**WARNING**

No panel struts on the opposing formwork!  
Risk of the formwork tipping over!

- ▶ Do not disconnect the gang-form from the crane until a large enough number of form ties have been installed to keep it safely in the upright.

- ▶ Detach the gang-form from the crane.
- ▶ Insert the remaining form ties. These form-tie points can be reached from the platforms.
- ▶ Continue lining up further gang-forms in this way, and link them together (see the section headed 'Inter-panel connections').

## Pouring



### NOTICE

Do not exceed the maximum permissible rate of placing.

#### Framed formwork Framax Xlife:

Permissible fresh-concrete pressure: See sections [Framax panel in detail](#) and [Tie rod system](#).



Observe the section 'Pressure of fresh concrete on vertical formwork, DIN 18218' in the Calculation Guide 'Doka formwork engineering' or contact Doka.



Observe DIN 4235 Part 2 'Compacting of concrete by vibrating; Compacting by internal vibrators'.

- ▶ Pour the concrete.
- ▶ Make only moderate use of vibrators, carefully coordinating the times and locations of vibrator use.

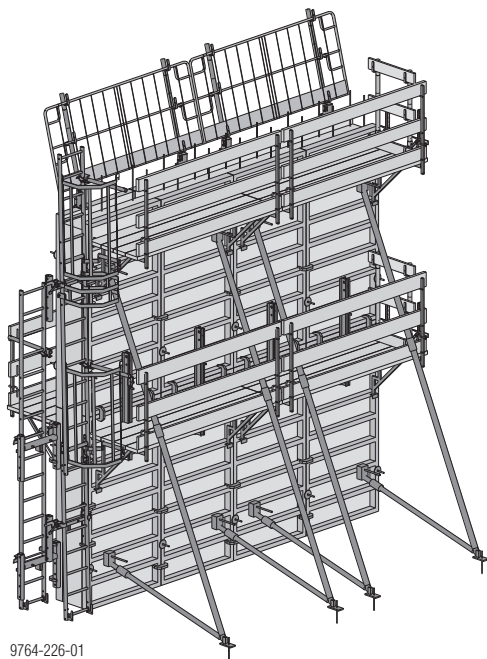

9764-226-01

## Stripping the formwork



### NOTICE

- ▶ Comply with the stipulated stripping times.
- ▶ Remove any loose items from the formwork and platforms, or secure them firmly.

**Begin work on stripping the formwork on the opposing formwork:**



### WARNING

- ▶ There must be at least as many form ties left in place as are needed to keep the panels safely in the upright.



### WARNING

No all-round guardrail system present on the pouring platform!

Danger to life from fatal falls!

- ▶ Use a personal fall-arrest system (e.g. safety harness)  
The Tie-off set PPE type A connected to the framed formwork panel serves as attachment point.

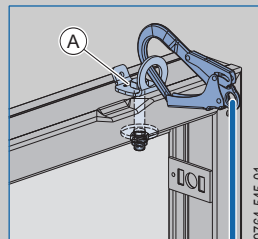

- ▶ Remove the top two rows of form ties and undo the connectors to the adjacent panels. These form-tie points can be reached from the platforms.
- ▶ Attach the gang-form (incl. platforms) to the crane.
- ▶ Working from the floor, remove the bottom two rows of form ties and undo the connectors to the adjacent panels.

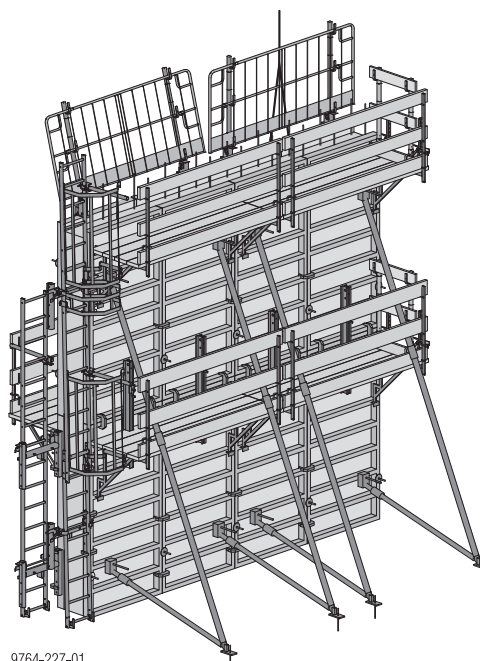

9764-227-01

**WARNING**

The formwork tends to adhere to the concrete. When stripping the formwork, do not try to break concrete cohesion using the crane!

Risk of crane overload.

- ▶ Use suitable tools such as timber wedges or a special pry-bar to detach the formwork from the concrete.
- ▶ Lift the gang-form away and to its next location, or place it flat on its back for intermediate storage.
- ▶ Clean residual concrete off the formwork sheet (see the section headed [Cleaning and care of your equipment](#)).
- ▶ Where the gang-form has panel struts attached to it, first attach this gang-form to the crane, and only then detach the floor anchorages of the panel struts.

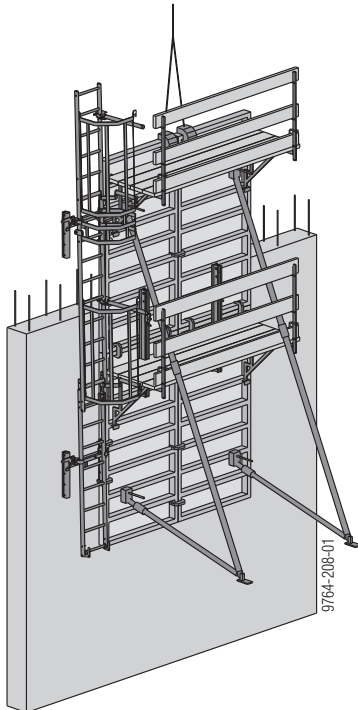

## Framax panel in detail

### High load-bearing capacity

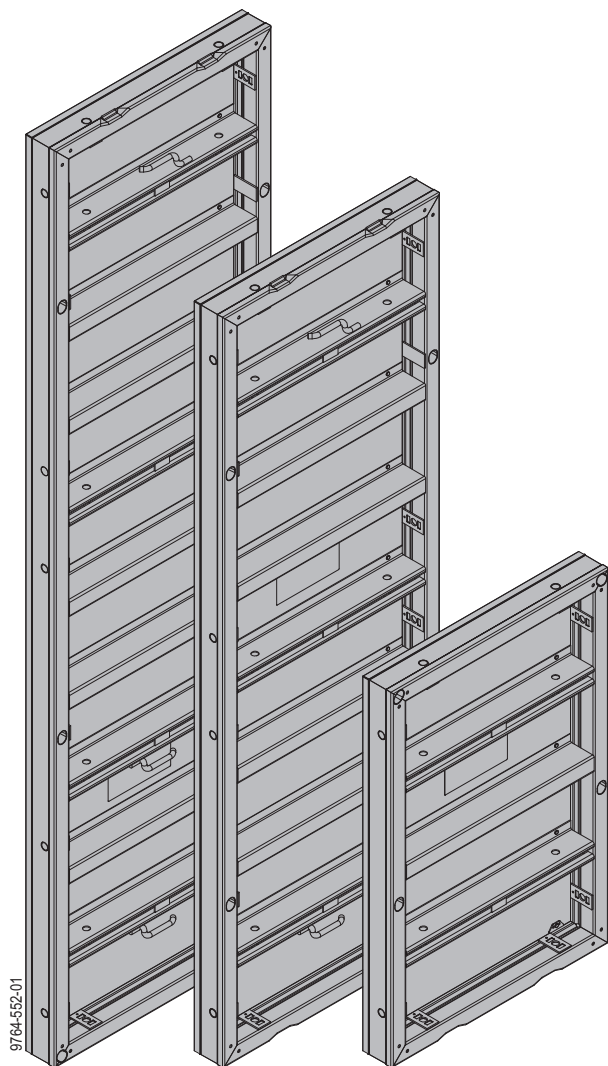

### Clean concrete surfaces with the innovative Xlife sheet

The Xlife sheet ensures high numbers of repeat use, it is less prone to damage and gives a superb concrete finish every time.

- High quality concrete finish
- Less touching-up needed
- Less cleaning - the Xlife sheet can be cleaned using a high-pressure spray cleaner
- The sheeting is screwed on from the back, preventing rivet impressions in the concrete and making cleaning easier

### Dimensionally stable, galvanised and powder-coated steel frame

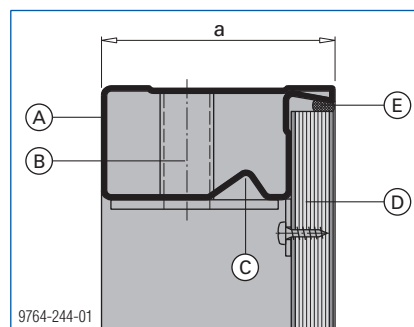

a ... 123 mm

- A Frame profile
- B Cross borehole
- C Continuous hardware slot for inter-panel connectors
- D Xlife sheet
- E Silicone sealing strip

**60 kN/m<sup>2</sup>** pressure of fresh concrete acting on whole area, to DIN 18218, where the surface planeness tolerances to DIN 18202 Table 3 Line 7 are observed.

**80 kN/m<sup>2</sup>** pressure of fresh concrete acting on whole area, to DIN 18218, where the surface planeness tolerances to DIN 18202 Table 3 Line 6 are observed.  
(Tie rod system 20.0 must be used)

- Dimensionally stable frame profiles
- Strong cross-profiles
- Powder coated, so easy to clean
- Edges are easy to clean - so panels always abut tightly
- All-round hardware slot for fastening the inter-panel connectors at any point required
- Hot-dip galvanised for long life
- Edges of formwork sheet are protected by frame profile
- Cross boreholes for corner configurations and stop-ends



#### WARNING

► It is forbidden to climb on the cross-profiles. The cross-profiles are NOT a substitute for a ladder.

## Accessories are easy to fasten in the function profile

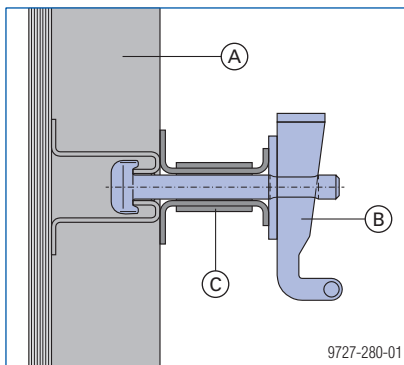

- A Framax Xlife panel
- B Framax wedge clamp
- C Framax universal waling

## Form-tie sleeves

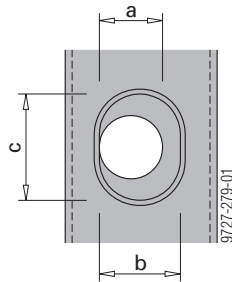

- a ... diameter 25 mm
- b ... 32 mm
- c ... 42 mm

- Tie rods are very easy to insert through the large, conical form-tie sleeves
- Tie rods 20.0mm can also be used here
- Only 2 form ties are needed for every 2.70 m of panel height

## Handles

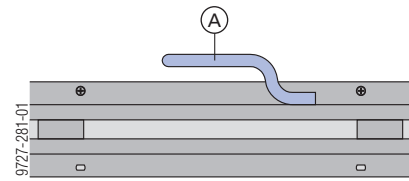

- A Integral handle



### WARNING

Do not use these handles as lifting points for crane-handling!

Danger of formwork dropping from crane!

- ▶ Use only suitable lifting accessories and lifting points. See the sections headed [Lifting by crane](#) and [Transporting, stacking and storing](#).

## Lifting edge

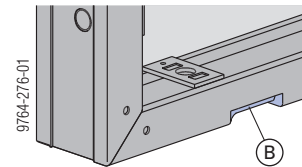

- B Lifting edge

- Practical lifting edge, as an insertion point for the aligning tool

# System grid

## Framax Xlife panels

The heights and widths of the Framax Xlife panels together result in a logical, advantageous increment-grid that makes this formwork highly flexible and economical.

- Easy planning and forming
- 15 cm grid
- Very few closures needed
- Clear joint pattern

### Panel widths

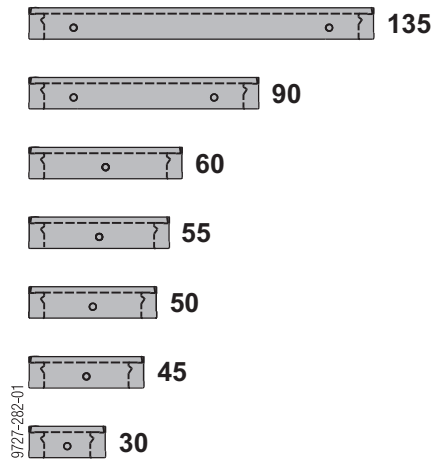

### Panel heights

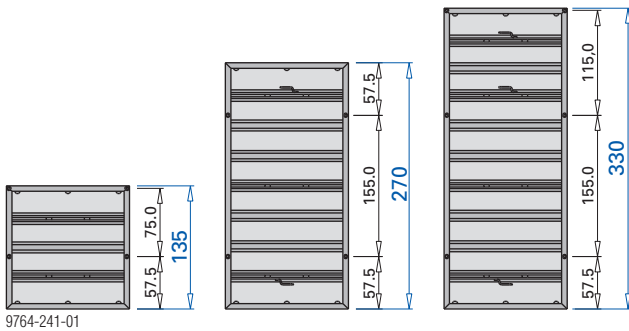

Dimensions in cm

## Extra-large panels

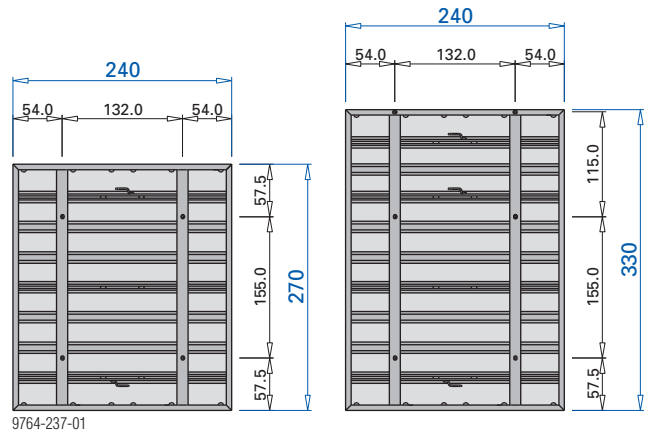

Dimensions in cm

## Framax Xlife universal panels

The special hole pattern makes these panels particularly suitable for efficient forming of:

- corners
- wall junctions
- stop-ends
- columns

### Panel widths

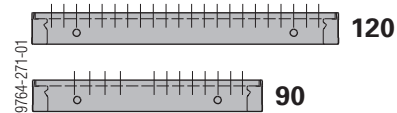

### Panel heights

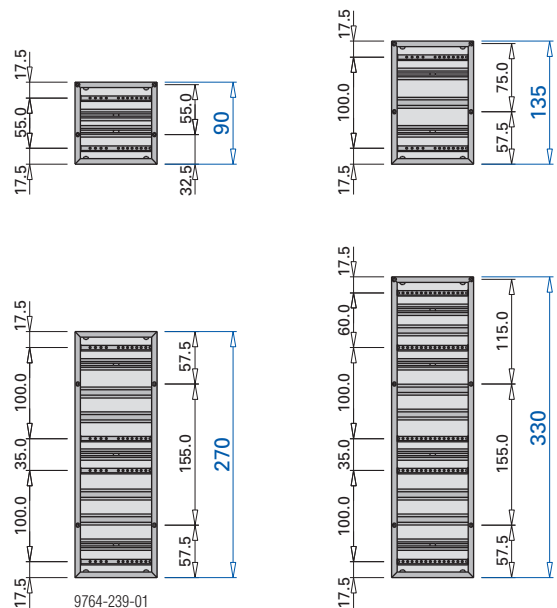

Dimensions in cm

## Inter-panel connections

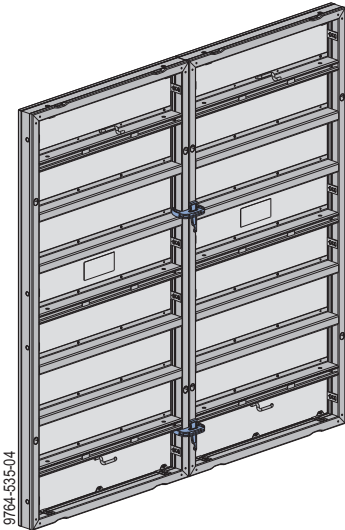

Attributes of the panel connectors:

- provide self-aligning, crane-handleable connections between the panels
- have no loose parts which might get lost
- dirt-resistant and hard-wearing for site use
- easy to fix, with a formwork hammer



**NOTICE**

- Use a formwork hammer weighing max. 800 g.
- Do not oil or grease wedged connections.

## Number of inter-panel connections

**Vertical inter-panel joint:**

Panel height (panel upright)	Number of clamps
1.35 m	2
2.70 m	2
3.30 m	3

Panel width (panel on its side)	Number of clamps
0.30 - 0.55 m	1
0.60 - 1.35 m	2

**Horizontal inter-panel joint:**

See 'Vertical stacking of panels' for details on the positions of the Framax quick acting clamps RU, Framax multi function clamps and Framax aligning clamps needed for **vertical stacking**.

**Note:**

For details regarding extra inter-panel connections on outside corners and stop-ends (for increased tensile loads) see the section headed 'Inter-panel connections for increased tensile loads'.

## Inter-panel connections are easy with Framax quick acting clamps RU

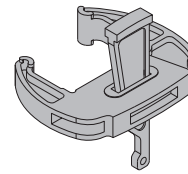

**Framax quick-acting clamp RU:**

- When used with (steel) **Framax Xlife**  
permitted tensile force: 15.0 kN  
permitted shear force: 6.0 kN  
permitted moment: 0.5 kNm
- When used with (aluminium) **Alu-Framax Xlife**  
permitted tensile force: 15.0 kN  
permitted shear force: 4.0 kN  
permitted moment: 0.25 kNm

The continuous hardware slot running around the inside of the frame profile means that panels can be fastened together at any point desired. This allows adjacent panels to be staggered in height, steplessly.

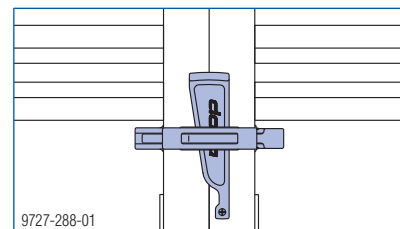
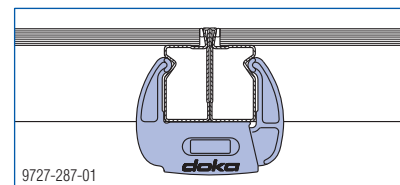

**Vertical stacking with moulded timber**

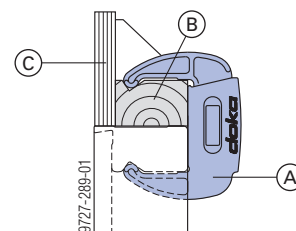

- A** Framax quick acting clamp RU
- B** Framax moulded timber 27mm (for 27mm formwork sheet) or Framax moulded timber 21mm (for 21mm formwork sheet) or Framax moulded timber 18mm (for 18mm formwork sheet) or
- C** Formwork sheet

## Filler inter-panel connection with Framax multi function clamp

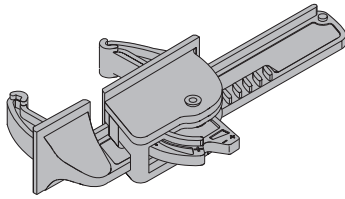

### Inter-panel connections

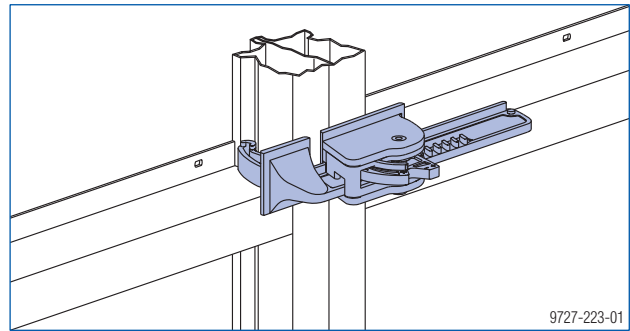

Joining the panels using the Framax multi function clamp provides additional bracing of the gang-form (as the clamp bears directly onto the profile).

### Filler connection up to 15 cm

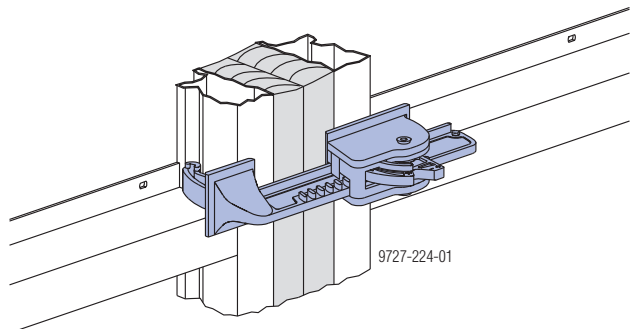

With its 15 cm clamping range, the Framax multi function clamp exactly matches the panel size-grid.

For more information, see the section headed [Length adjustment using closures](#).

### Squared timber connection up to 20 cm

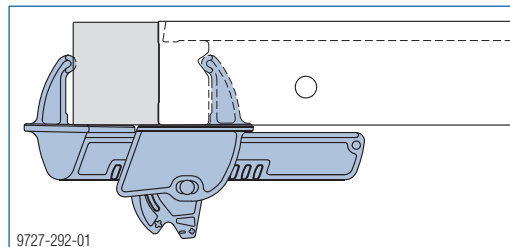

### Corner connection for foundations

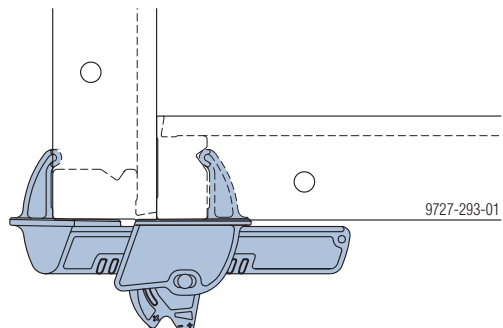

#### Framax multi function clamp:

- When used with (steel) **Framax Xlife**

Permitted tensile force: 15.0 kN

Permitted shear force: 9.0 kN

Permitted moment: 0.9 kNm

- When used with **Alu-Framax Xlife**

Permitted tensile force: 15.0 kN

Permitted shear force: 6.0 kN

Permitted moment: 0.45 kNm

Values apply only when mounted on profile.

Particularly when panels are stacked in the vertical, the fact that the clamp bears directly on the profiles means that there is often no need for any extra bracing of the panels with universal walings.

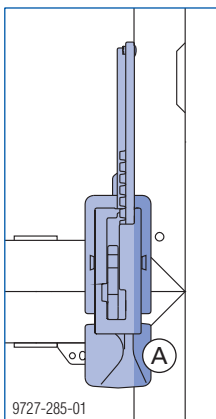

9727-285-01

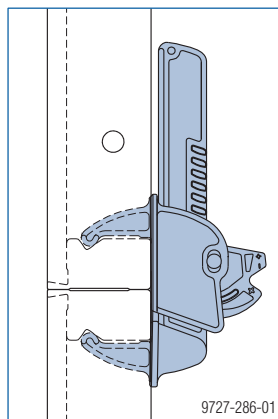

9727-286-01

**A** Contact surface on the profile

## Bracing inter-panel connection with Framax aligning clamp

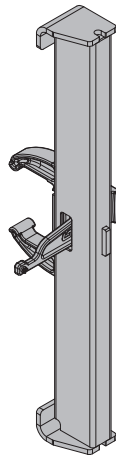

### Framax aligning clamp:

Permitted tensile force: 15.0 kN

Permitted shear force: 6.0 kN

Permitted moment: 1.5 kNm

Values apply only when mounted on profile.

Particularly when panels are stacked in the vertical, the fact that the clamp bears directly on the profiles means that there is often no need for any extra bracing of the panels with universal walings.

The installation procedure is similar to that for the Framax quick acting clamp RU.

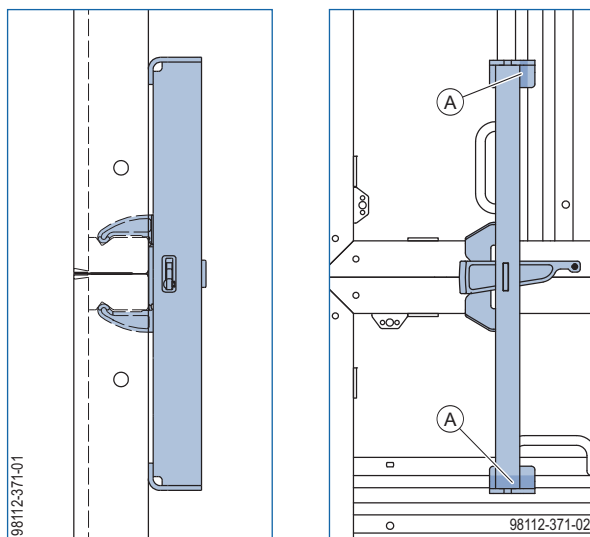

**A** Contact surface on the profile

## Panel bracing with Framax universal waling

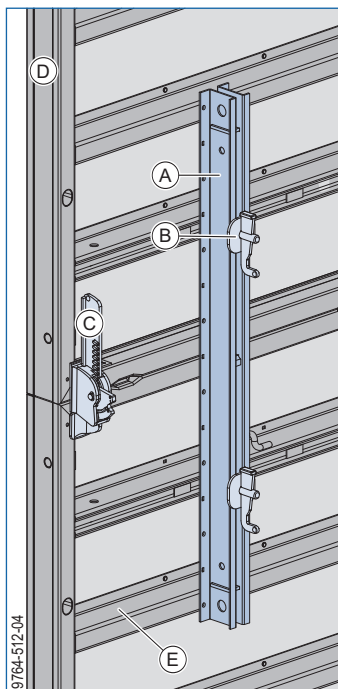

- A Framax universal waling 1.50m
- B Framax wedge clamp
- C Framax multi function clamp
- D Framax Xlife panel
- E Cross profile as bearing surface for universal waling

With **closures**, the universal walings bring the gang-forms firmly into alignment and transfer the form-tie forces to the framed panels.

Using additional universal walings gives gang-forms better rigidity, especially in higher **vertically stacked configurations**. This makes it possible to pick up and set down large gang-forms by crane without any problems. The additional universal walings are also useful for transferring the loads from platforms.

### Note:

Instead of the universal waling, it is also possible to use a Multi-purpose waling WS10 Top50.

### Framax universal waling:

- When used with (steel) **Framax Xlife**  
Permitted moment (for vertical stacking of panels): 5.0 kNm  
Due to the permitted tensile load of 14 kN in the function profile, even stiffer components such as Multi-purpose walings WS10 Top50 are also subject to: permitted moment 5.0 kNm
- When used with (aluminium) **Alu-Framax Xlife**  
Permitted moment (for vertical stacking of panels): 4.3 kNm  
Due to the permitted tensile load of 12 kN in the function profile, even stiffer components such as Multi-purpose walings WS10 Top50 are also subject to: permitted moment 4.3 kNm

## How to attach

### using the Framax wedge clamp or universal clamp

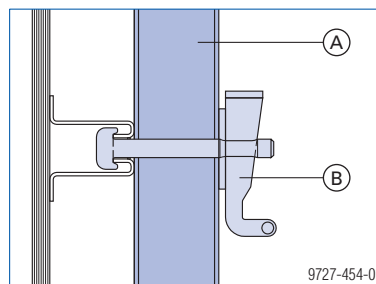

- A Framax universal waling
- B Framax wedge clamp or Universal clamp 5-10cm



### NOTICE

Do not oil or grease wedged connections.

### using the Framax universal fixing bolt and Super plate

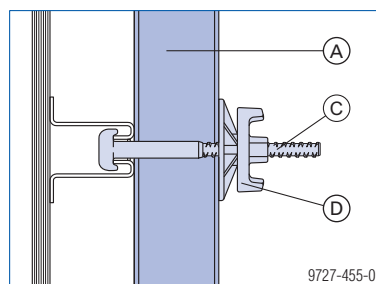

- A Framax universal waling
- C Framax universal fixing bolt
- D Super plate 15.0

## Vertical stacking of panels

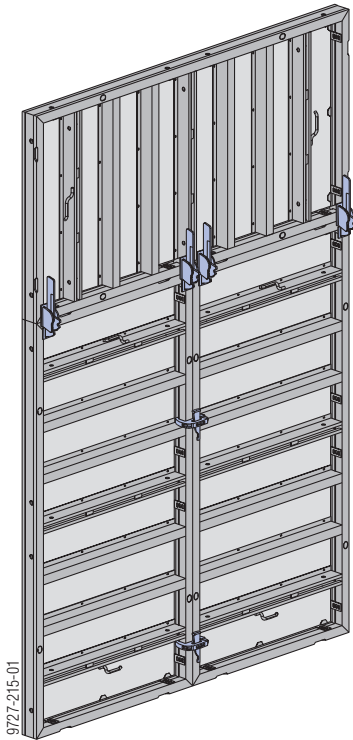

### NOTICE

The values and information stated here apply to **standard gang-forms**:

- Standard gang-forms are gang-forms consisting entirely of panels with **widths of 0.30m to 1.35m**.
- Examples of gang-forms containing extra-large panels (e.g. with widths of 2.40m and 2.70m) are illustrated on the following pages.

For detailed planning, we recommend using Tipos-Doka.



The **planning software Tipos-Doka** is always very helpful when it comes to finding the optimum technical and economical solution for the formwork issue concerned.

## with Framax multi function clamp

### Number of Framax multi function clamps needed at each vertically stacked panel joint

Width of upright panels	Framax multi function clamp
0.30 - 0.55m	1
0.60 - 1.35m	2

### N° of universal walings at each vertically stacked panel joint

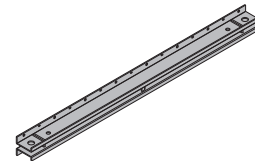

#### Formwork heights of up to 4.05 m:

- Per 2.70 m of gang-form width: 1 universal waling
- Exception:
  - Lightweight pouring platform with single brackets (Framax bracket 90):  
no universal waling

#### Formwork heights of over 4.05 m and up to 5.40 m:

- Per 1.35 m of gang-form width: 1 universal waling
- Exception:
  - Horizontal panel placed at top of gang:  
no universal waling
  - All other horizontal panels:  
only 1 universal waling per 2.70 m of gang-form width

#### Formwork heights of up to 8.10 m:

- Per 1.35 m of gang-form width: 1 universal waling
- Exception:
  - Horizontal panel placed at top of gang:  
only 1 universal waling per 2.70 m of gang-form width

## with Framax quick acting clamp RU

### Number of Framax quick acting clamps RU needed at each vertically stacked panel joint

Width of upright panels	Framax quick acting clamp RU
0.30 - 0.55m	1
0.60 - 1.35m	2

### N° of universal walings at each vertically stacked panel joint

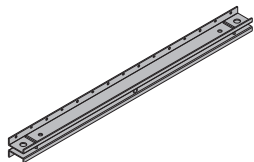

### Gang-form with pouring platform

#### Formwork heights of up to 8.10 m:

- Per 1.35 m of gang-form width: 1 universal waling
- Exception:
  - Horizontal panel placed at top of gang: only 1 universal waling per 2.70 m of gang-form width.

### Gang-form without pouring platform

#### Formwork heights of over 3.75 m and up to 5.40 m:

- Per 1.35 m of gang-form width: 1 universal waling
- Exception:
  - Up to 0.60 m wide horizontal panel placed at top of gang: no universal waling.
  - Over 0.60 m wide horizontal panel placed at top of gang: only 1 universal waling per 2.70 m of gang-form width

#### Formwork heights of up to 8.10 m:

- Per 1.35 m of gang-form width: 1 universal waling
- Exception:
  - Up to 0.90 m wide horizontal panel placed at top of gang: only 1 universal waling per 2.70 m of gang-form width

## with Framax aligning clamp

### Number of Framax aligning clamps needed at each vertically stacked panel joint

Width of upright panels	Framax aligning clamp
0.30 - 0.55m	1
0.60 - 1.35m	2

Positions of the necessary connectors, form-tie components and accessories for:

- Lifting and setting down
- Crane-handling
- Pouring platform
- Concrete pouring

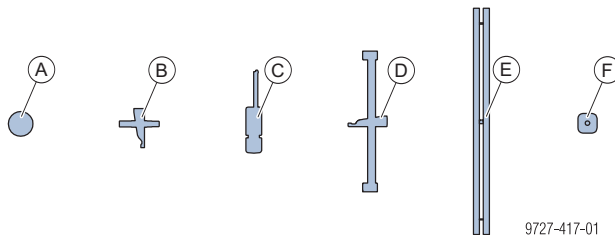

9727-417-01

- A Tie rod + Super plate
- B Framax quick acting clamp RU
- C Framax multi function clamp
- D Framax aligning clamp
- E Framax universal waling 1.50m
- F Framax wedge clamp

#### Framax quick acting clamp RU:

Permissible tensile force: 15.0 kN  
 Permissible shear force: 6.0 kN  
 Permissible moment: 0.5 kNm

#### Framax multi function clamp:

Permissible tensile force: 15.0 kN  
 Permissible shear force: 9.0 kN  
 Permissible moment: 0.9 kNm  
 Values apply only when mounted on profile.

#### Framax aligning clamp:

Permissible tensile force: 15.0 kN  
 Permissible shear force: 6.0 kN  
 Permissible moment: 1.5 kNm  
 Values apply only when mounted on profile.

#### Framax universal waling:

Permissible moment (for vertical stacking): 5.0 kNm  
 Due to the permissible tensile load of 14 kN in the function profile, even stiffer components such as Multi-purpose walings WS10 Top50 are also subject to: permissible moment 5.0 kNm

## Framax Xlife panel 2.70m

with Framax multi function clamp

### Formwork height: 300 cm

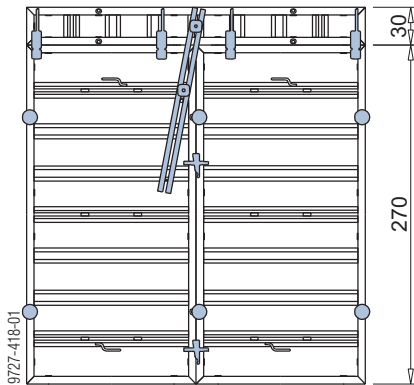

When using a lightweight pouring platform with single brackets (Framax bracket 90), the universal waling is not necessary.

### Formwork height: 315, 330 and 360 cm

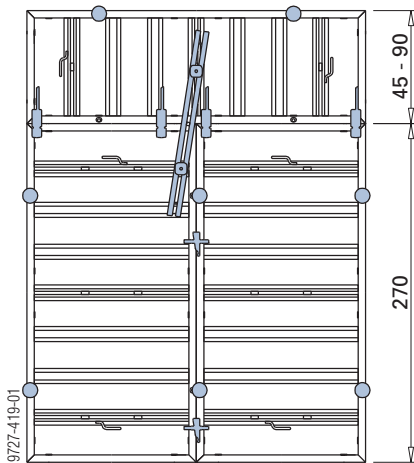

When using a lightweight pouring platform with single brackets (Framax bracket 90), the universal waling is not necessary.

### Formwork height: 405 cm

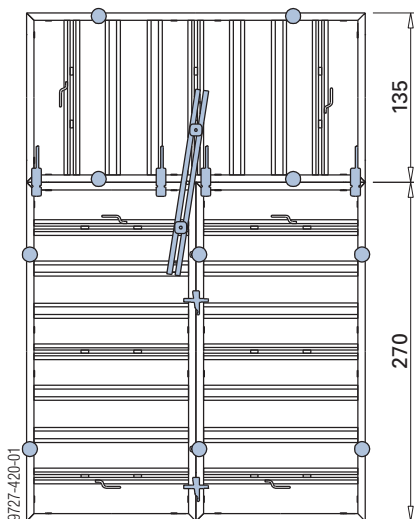

When using a lightweight pouring platform with single brackets (Framax bracket 90), the universal waling is not necessary.

### Formwork height: 405 cm

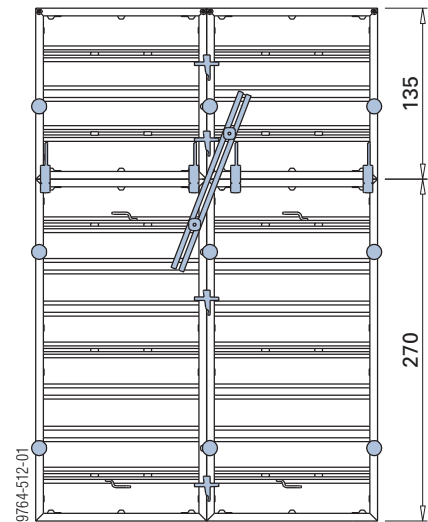

When using a lightweight pouring platform with single brackets (Framax bracket 90), the universal waling is not necessary.

### Formwork height: 435, 450, 465, 495 and 540 cm

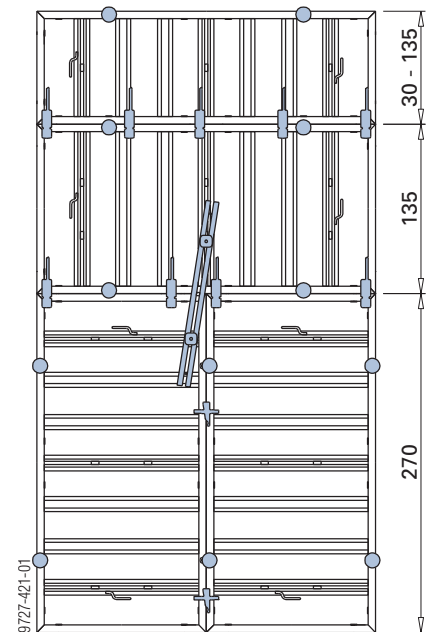

**Formwork height: 540 cm**

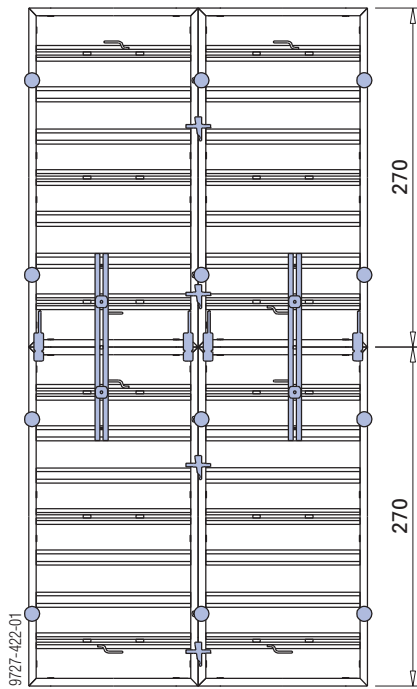

**Formwork height: 675 cm**

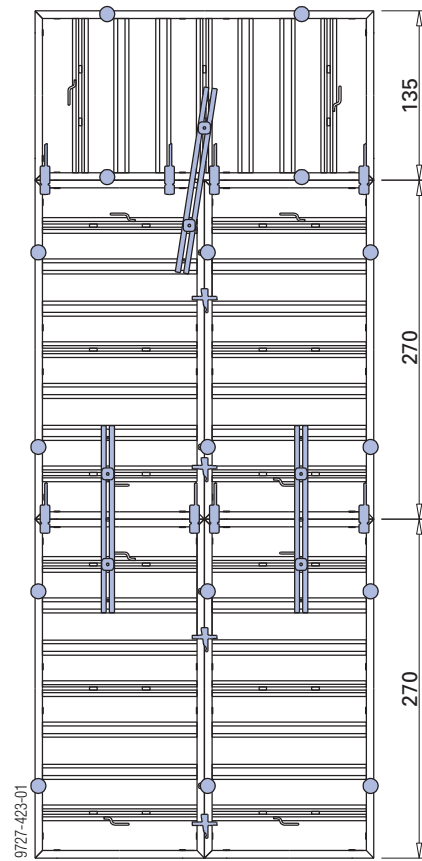

**Formwork height: 570, 585, 600 and 630 cm**

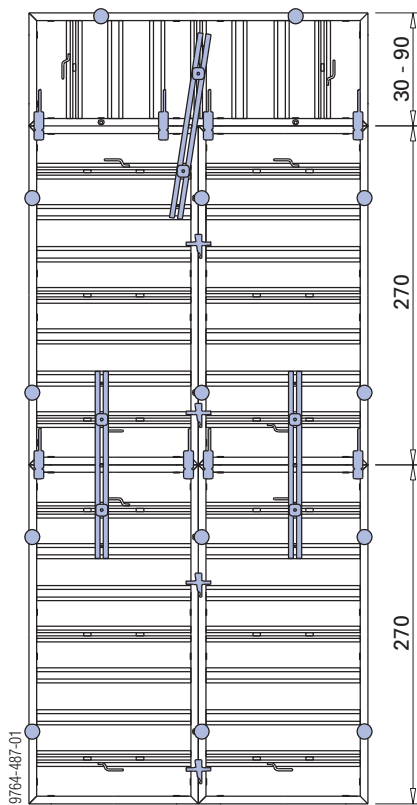

**Formwork height: 705, 720, 735, 765 and 810 cm**

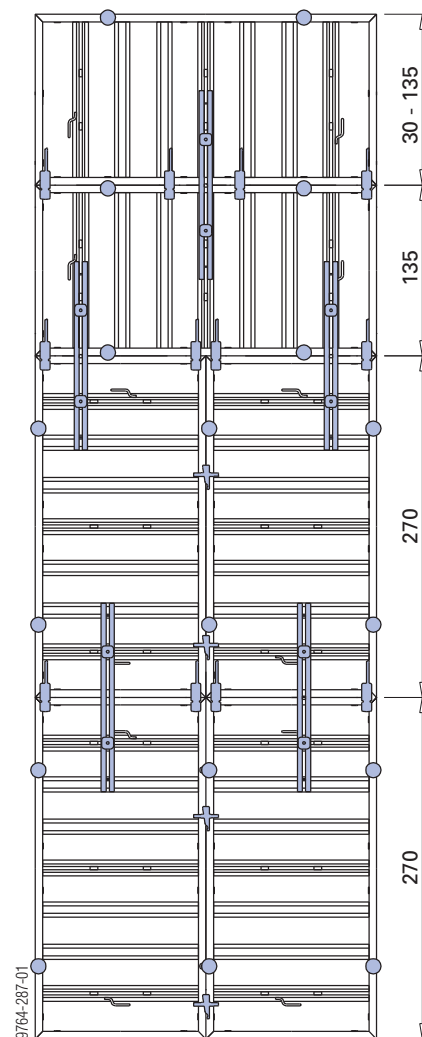

**Formwork height: 810 cm**

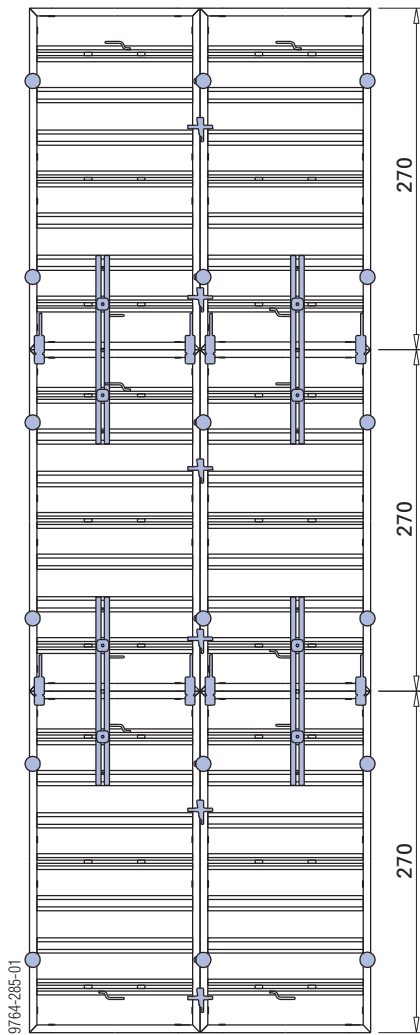

**Formwork height: 315, 330 and 360 cm**

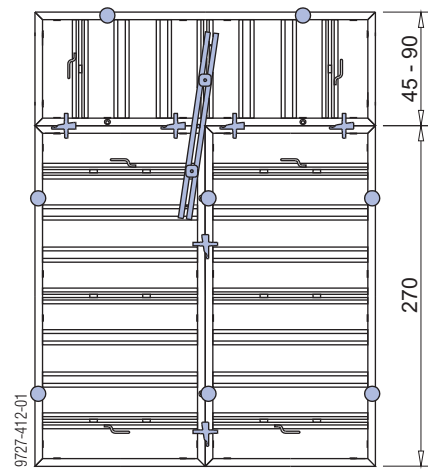

Universal waling only needed if pouring platforms are to be used.

**Formwork height: 405 cm**

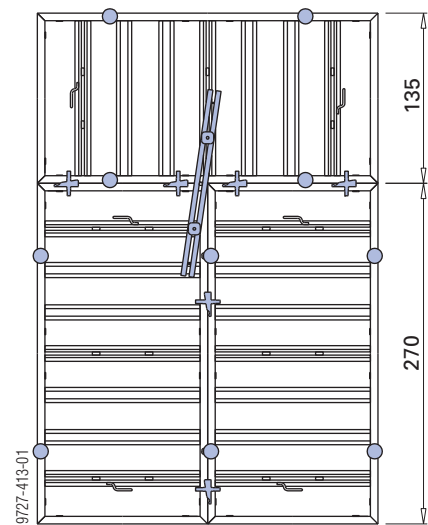

with Framax quick acting clamp RU

**Formwork height: 300 cm**

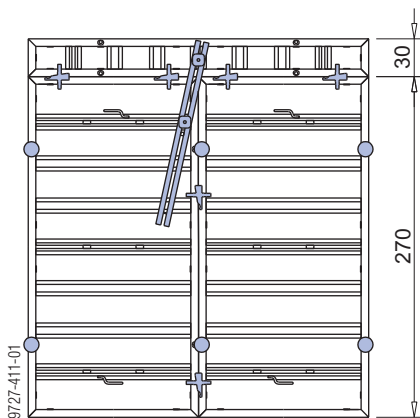

Universal waling only needed if pouring platforms are to be used.

**Formwork height: 405 cm**

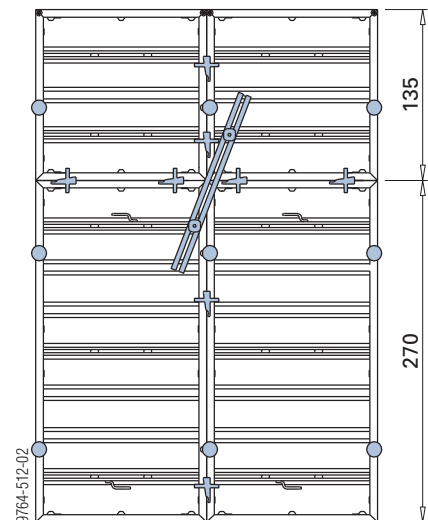

**Formwork height: 435 and 450 cm**

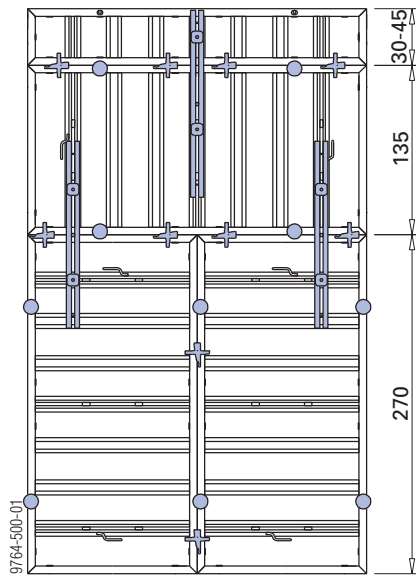

Universal waling on top-placed horizontal panel only needed if pouring platforms are to be used.

**Formwork height: 495 and 540 cm**

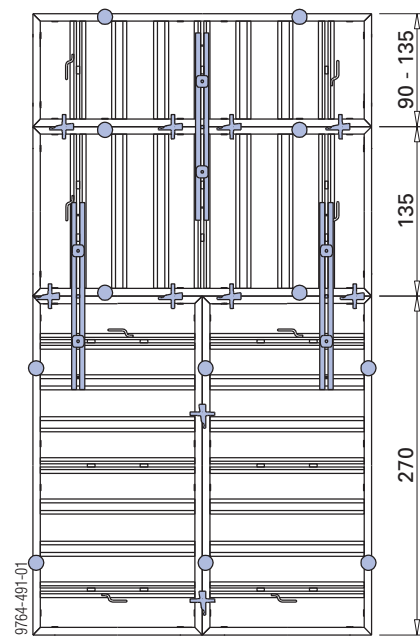

**Formwork height: 465 cm**

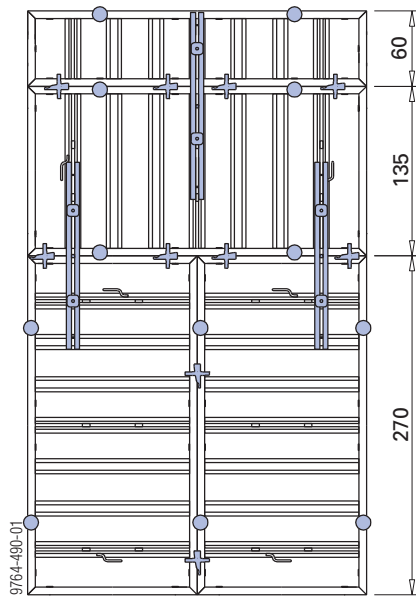

Universal waling on top-placed horizontal panel only needed if pouring platforms are to be used.

**Formwork height: 540 cm**

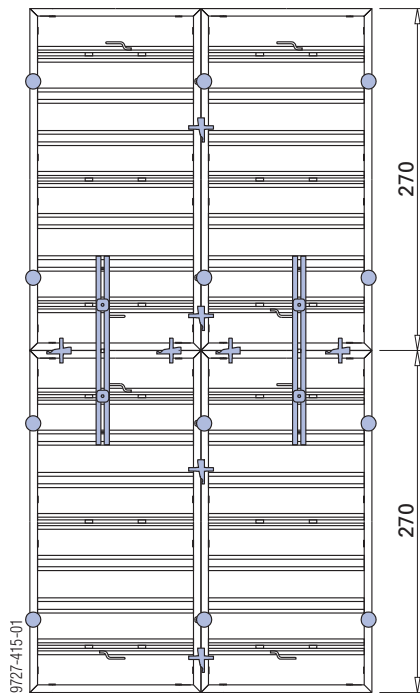

Formwork height: 570, 585, 600 and 630 cm

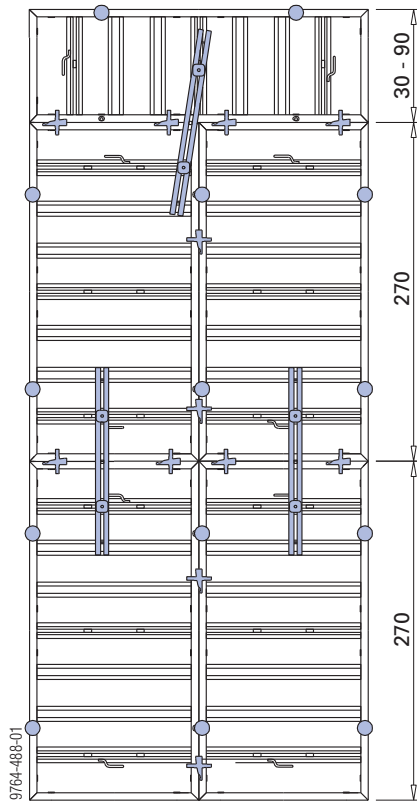

Formwork height: 705 and 720 cm

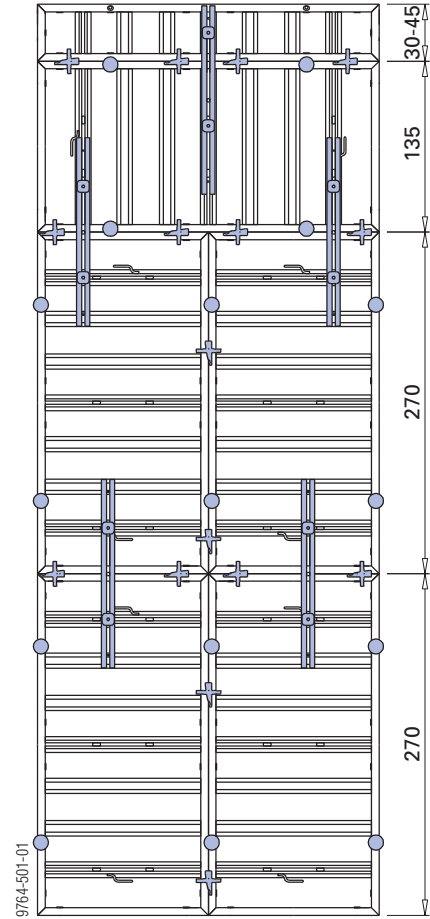

Formwork height: 675 cm

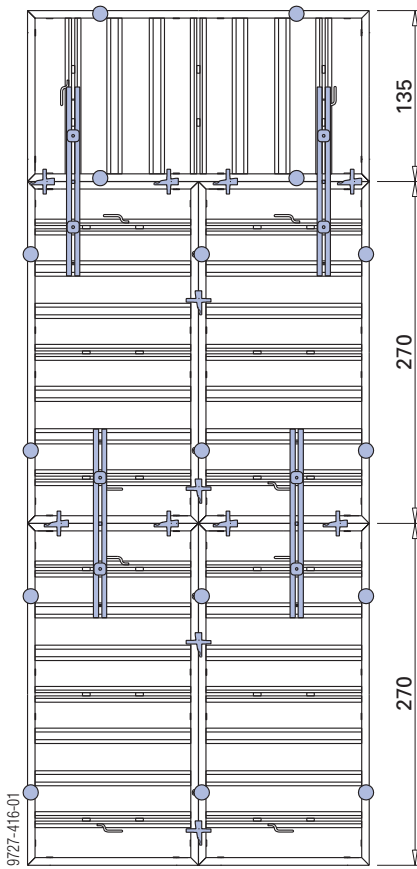

Formwork height: 735 and 765 cm

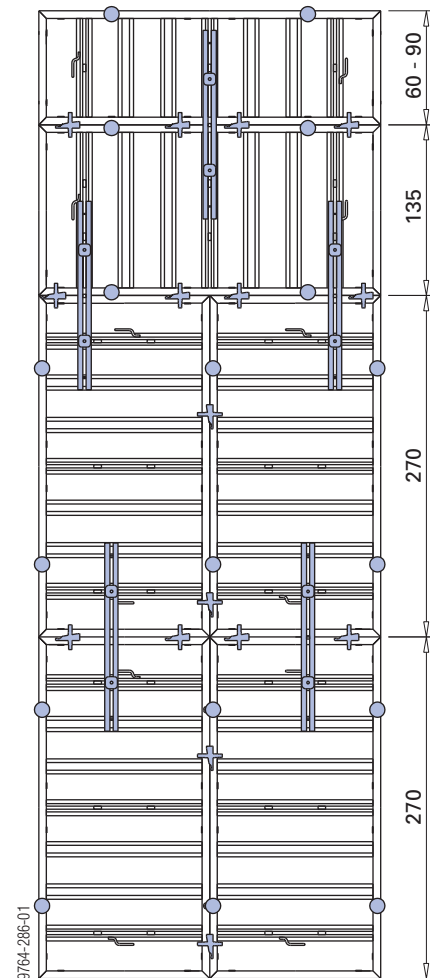

**Formwork height: 810 cm**

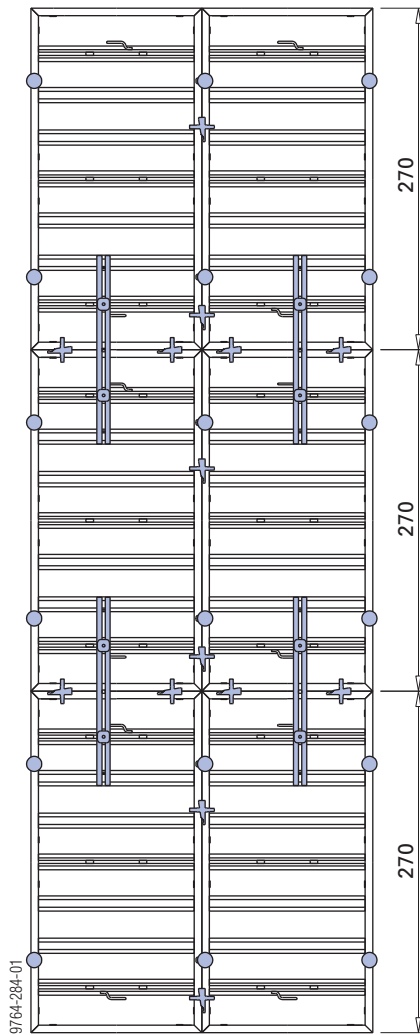

**with Framax aligning clamp**

**Formwork height: 325, 330, 345, 360 and 405 cm**

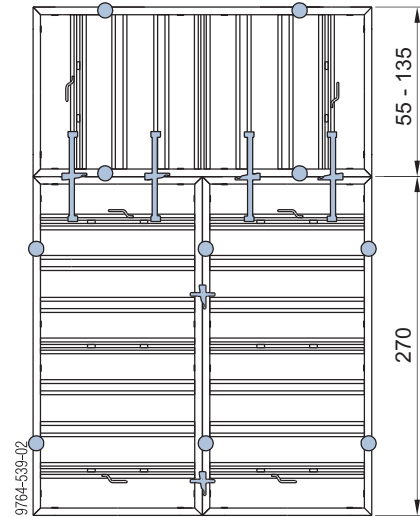

**Formwork height: 460, 465, 480 and 495 cm**

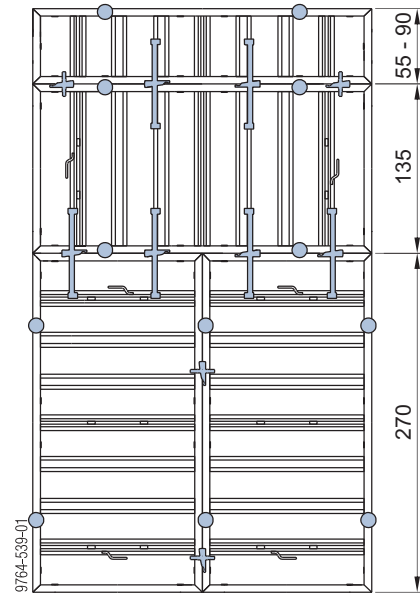

# Framax Xlife panel 3.30m

with Framax quick acting clamp RU

## Formwork height: 360 and 375 cm

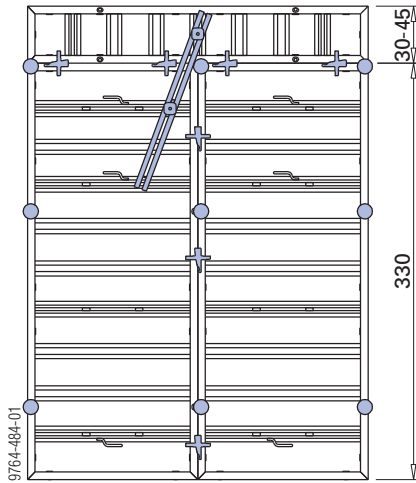

Universal waling only needed if pouring platforms are to be used.

## Formwork height: 390 cm

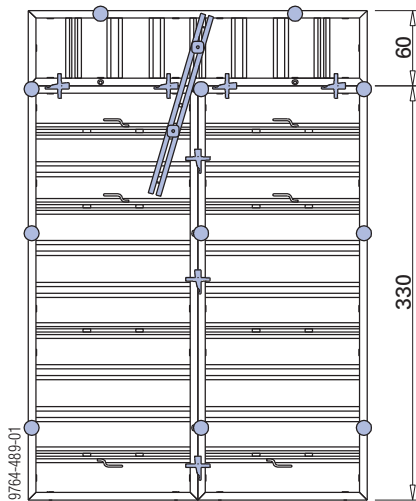

Universal waling only needed if pouring platforms are to be used.

## Formwork height: 420 and 465 cm

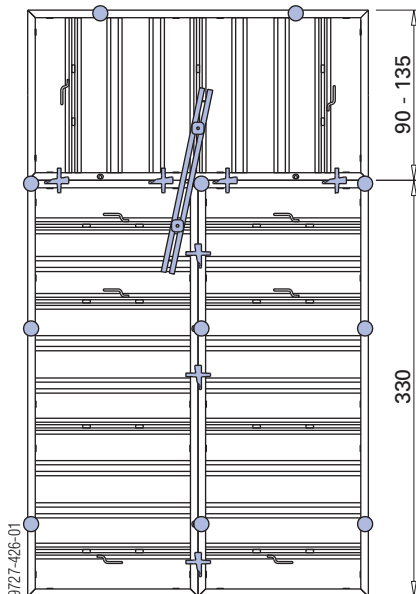

## Formwork height: 465 cm

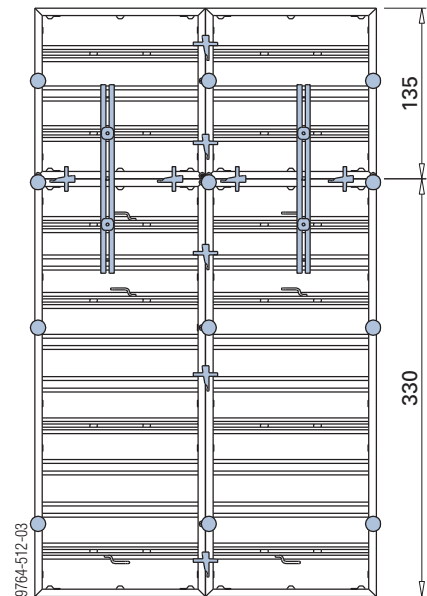

## Formwork height: 495 and 510 cm

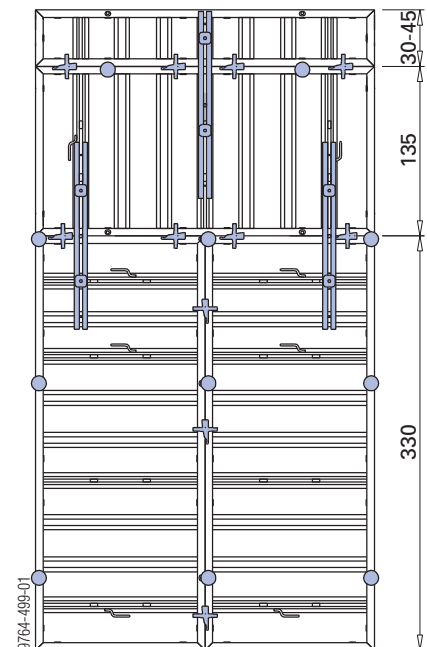

Universal waling on top-placed horizontal panel only needed if pouring platforms are to be used.

**Formwork height: 525 cm**

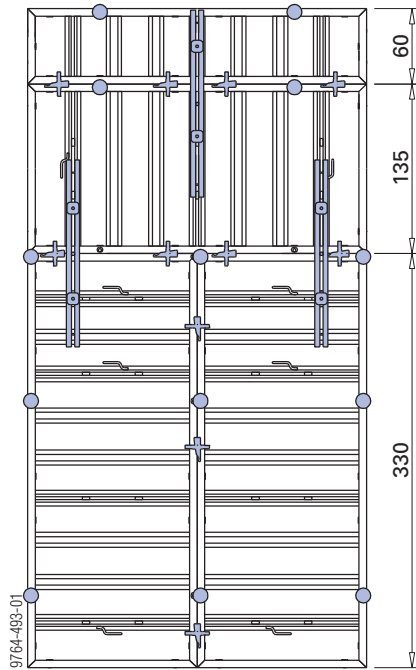

Universal waling on top-placed horizontal panel only needed if pouring platforms are to be used.

**Formwork height: 555 cm**

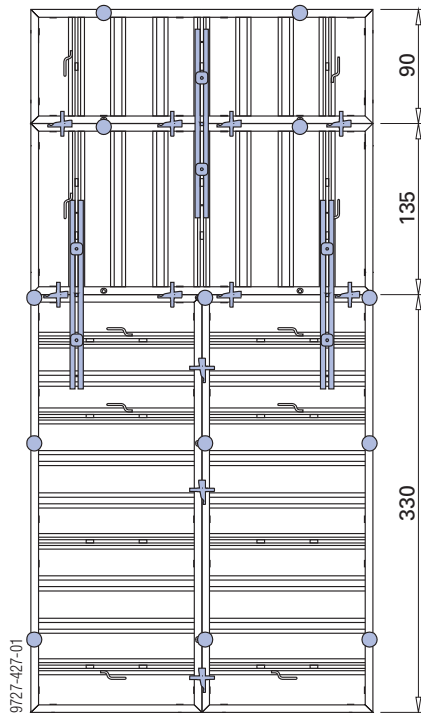

**Formwork height: 600 cm**

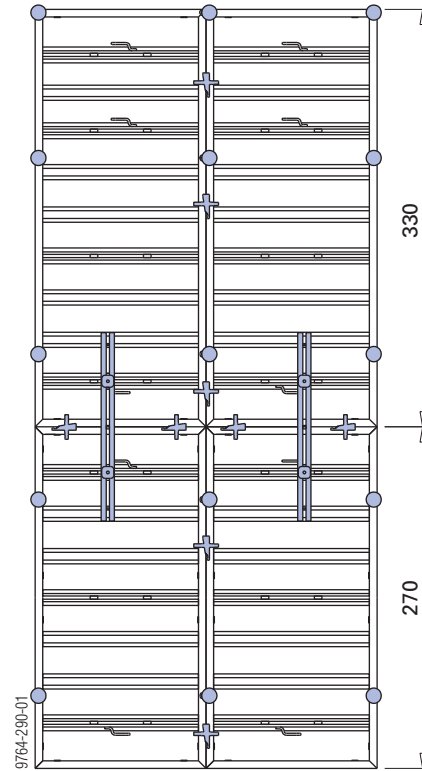

Up to a pour-height of 5.85 m, no form ties are needed at the top edge of the formwork.

**Formwork height: 660 cm**

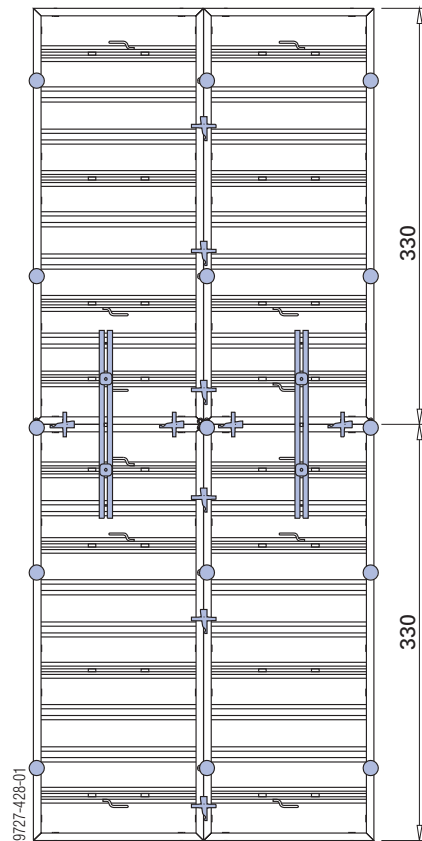

with Framax aligning clamp

Formwork height: 385, 390, 405, 420 and 465 cm

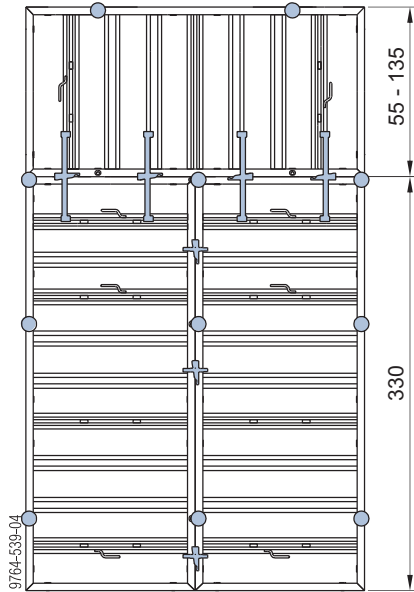

Formwork height: 520 and 525 cm

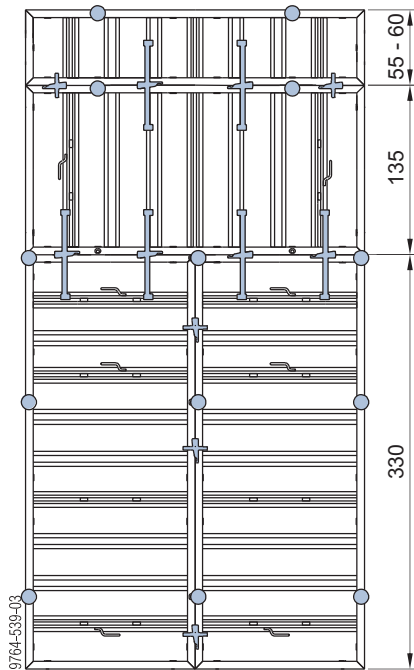

Framax Xlife panel 2.40x2.70m

with Framax multi function clamp

Formwork height: 270, 285, 300 and 330 cm

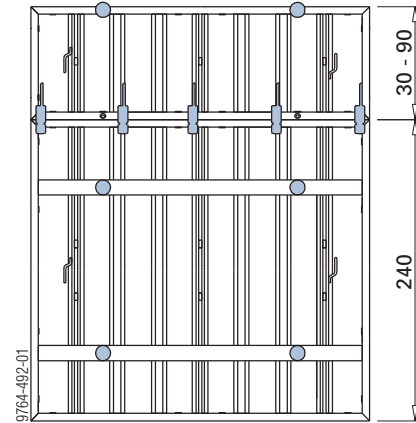

Formwork height: 375 cm

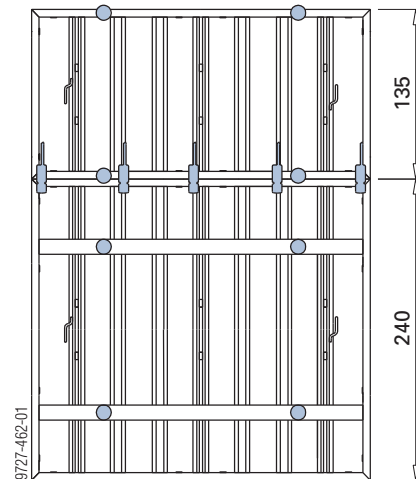

Formwork height: 480 cm

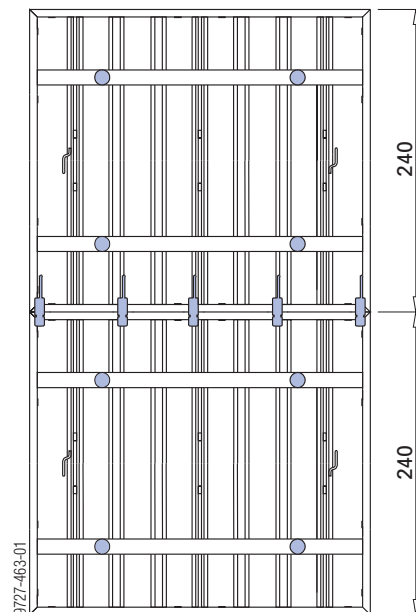

**Formwork height: 405 cm**

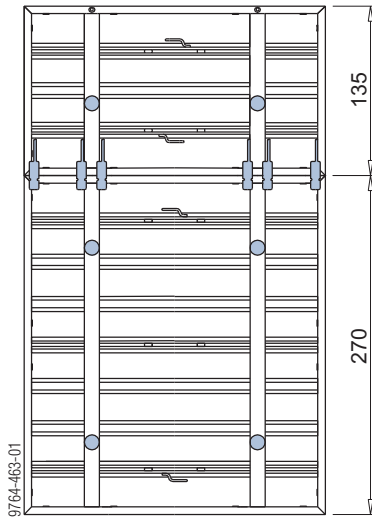

with Framax quick acting clamp RU

**Formwork height: 270, 285, 300 and 330 cm**

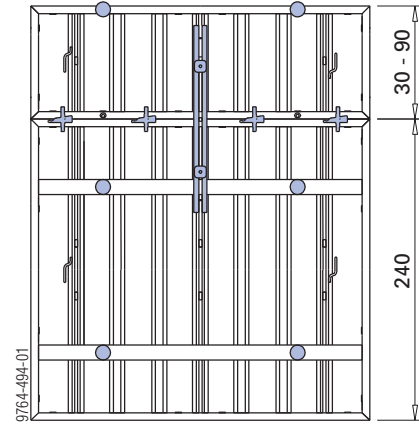

Universal waling only needed if pouring platforms are to be used.

**Formwork height: 540 cm**

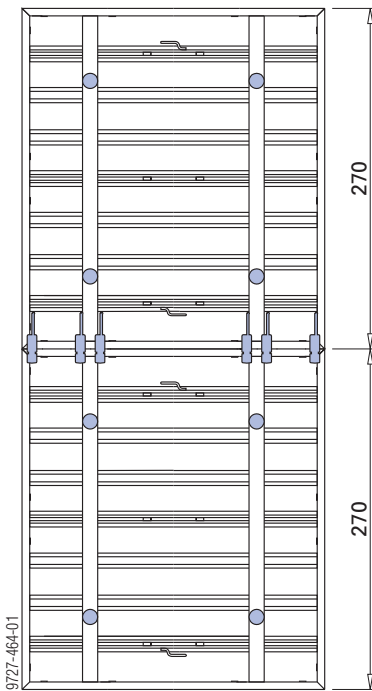

**Formwork height: 375 cm**

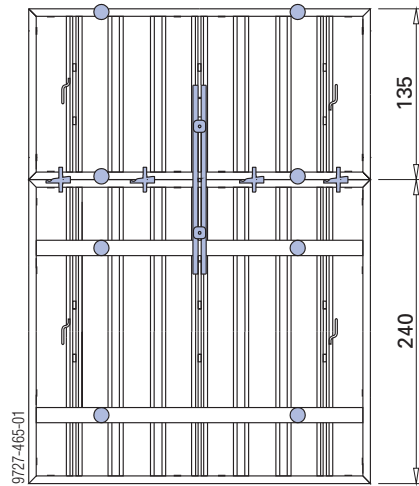

**Formwork height: 480 cm**

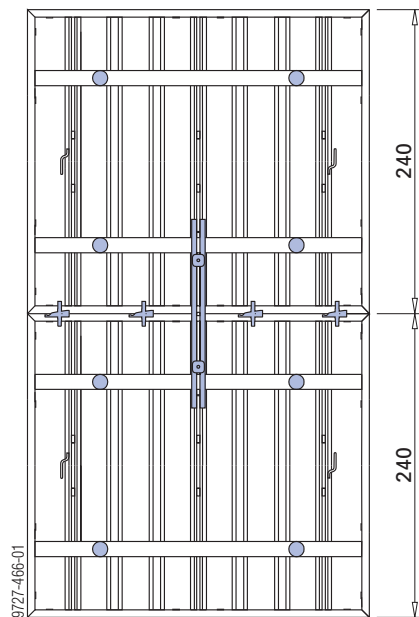

**Formwork height: 405 cm**

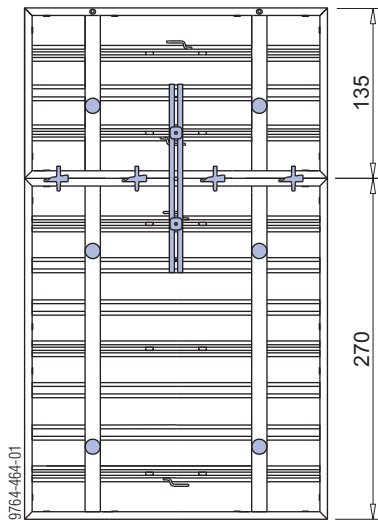

**Framax Xlife panel 2.40x3.30m**

with Framax quick acting clamp RU

**Formwork height: 270, 285, 300 and 330 cm**

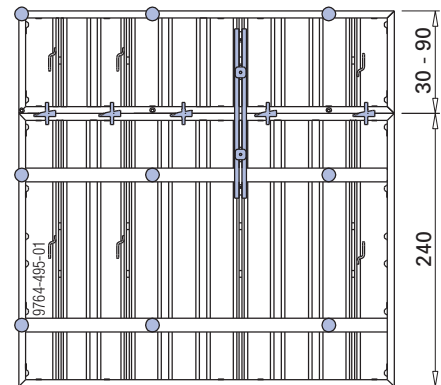

**Formwork height: 540 cm**

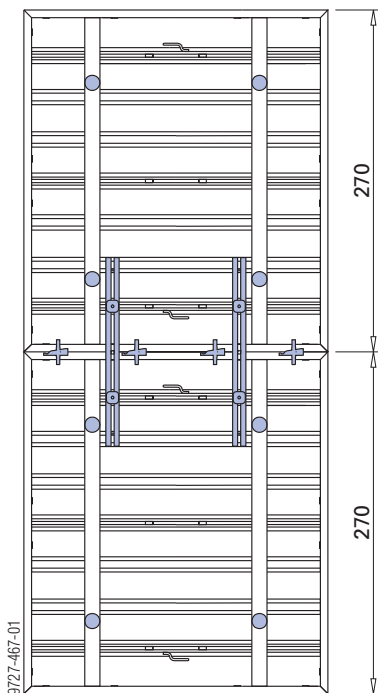

Universal waling only needed if pouring platforms are to be used.

**Formwork height: 375 cm**

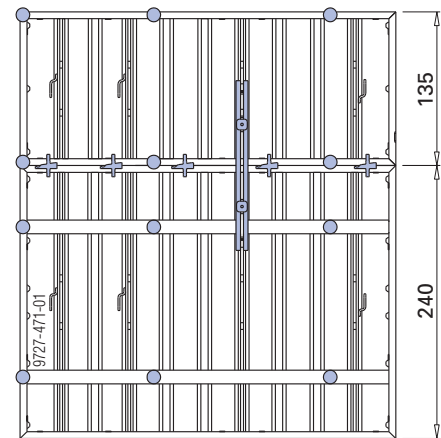

**Formwork height: 480 cm**

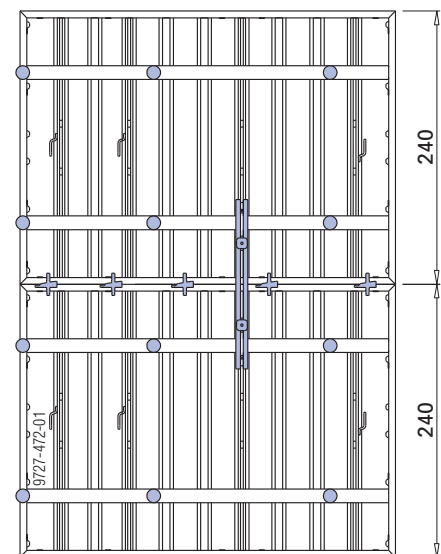

**Formwork height: 405, 420 and 435 cm**

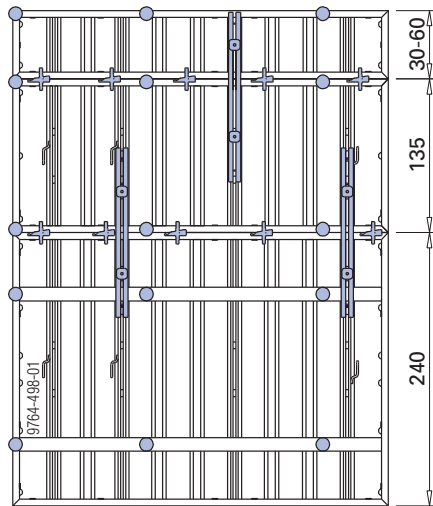

Universal waling on top-placed horizontal panel only needed if pouring platforms are to be used.

**Formwork height: 540 and 570 cm**

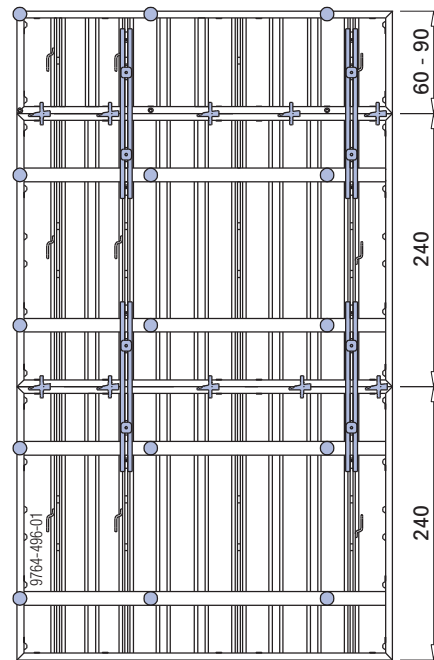

**Formwork height: 465 and 510 cm**

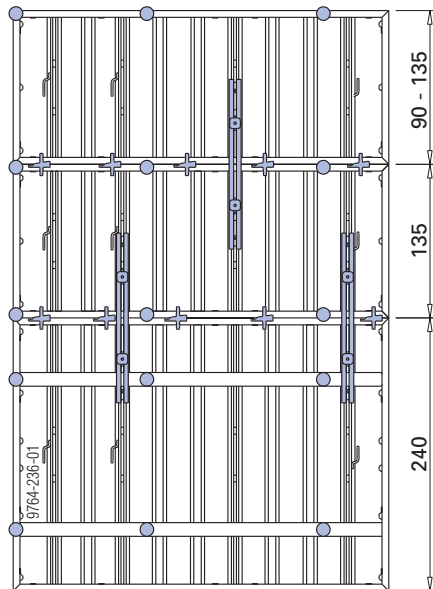

**Formwork height: 615 cm**

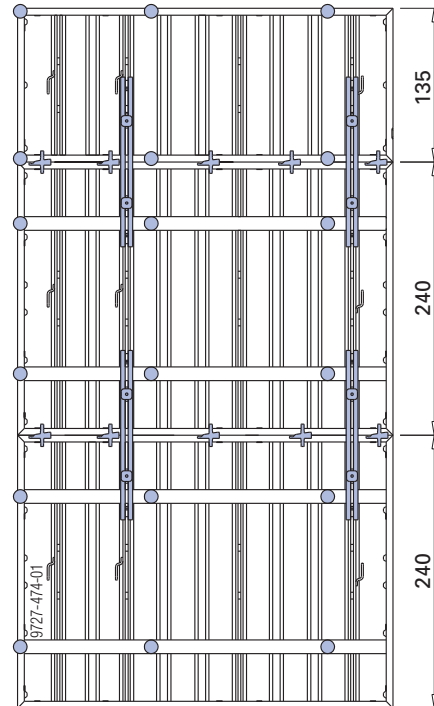

**Formwork height: 510 and 525 cm**

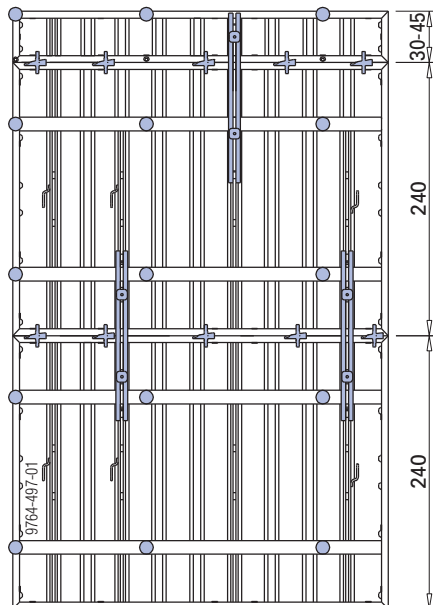

Universal waling on top-placed horizontal panel only needed if pouring platforms are to be used.

**Formwork height: 720 cm**

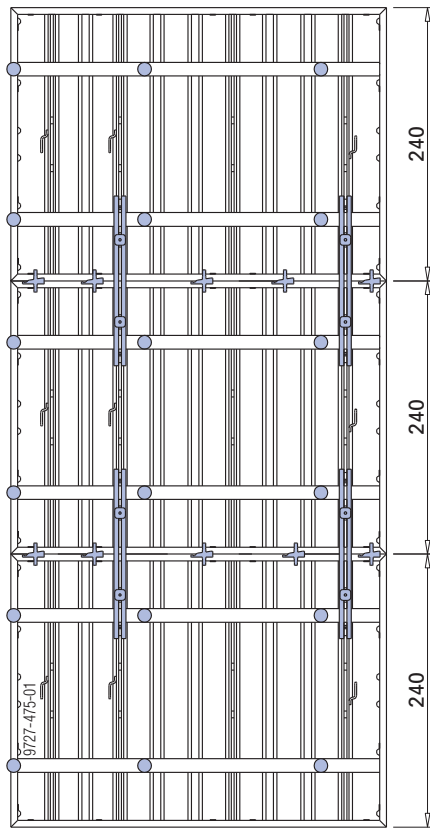

**Formwork height: 600 cm**

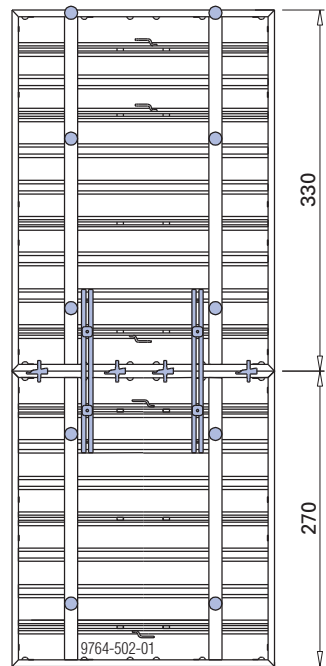

Up to a pour-height of 5.85 m, no form ties are needed at the top edge of the formwork.

**Formwork height: 660 cm**

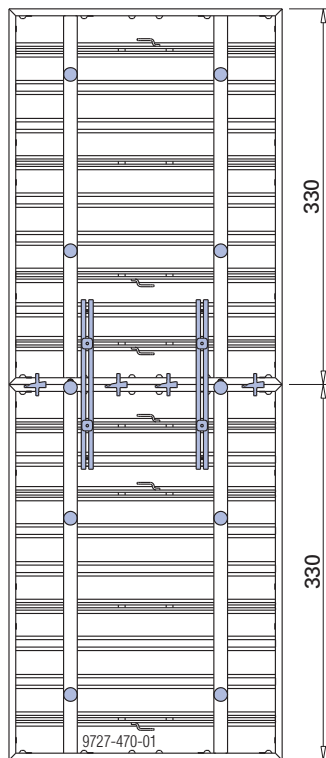

**Formwork height: 465 cm**

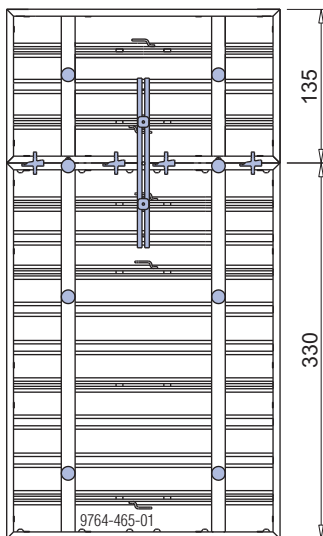

# Tie rod system

## Placing form ties in the frame profile

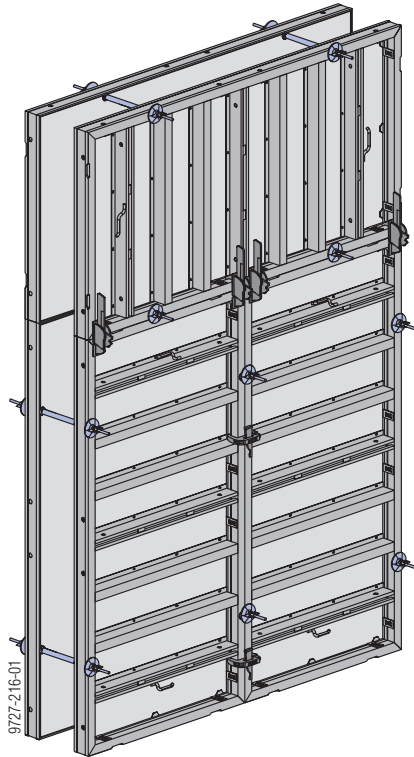

**NOTICE**

- Fix a form tie in every anchoring sleeve that is not covered by a super plate.
- Always tie in the larger (wider) of the two panels.
- For exceptions, see sections:
  - [Length adjustment using closures](#)
  - [Vertical stacking of panels](#)

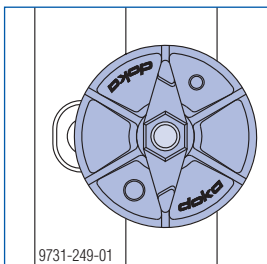

**WARNING**

Delicate rod steel!

- Never weld or heat tie rods.
- Tie rods that are damaged or have been weakened by corrosion or wear must be withdrawn from use.

**Note:**

Seal off unused anchoring sleeves with **Universal plugs R20/25**.



**Tie-rod wrench 15.0/20.0**

For turning and holding the tie rods.

**Note:**

Doka also offers cost-effective solutions for creating watertight form-tie points.

## The Doka tie rod system 15.0

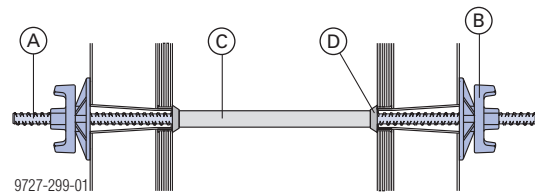

- A** Tie rod 15.0mm
- B** Super plate 15.0
- C** Plastic tube 22mm
- D** Universal cone 22/10mm

**Note:**

The Plastic tubes 22mm are left in the concrete and are sealed off with **Plugs 22mm**.

**Tie rod 15.0mm:**

Permitted load-bearing capacity, allowing a 1.6 : 1 factor of safety against failure: 120 kN

Permitted load-bearing capacity to DIN 18216: 90 kN



The Friction type ratchet SW27 or Box spanner 27 0.65m can be used for **low-noise releasing and tightening** of the following anchoring components:

- Super plate 15.0
- Wing nut 15.0
- Star grip nut 15.0

## Distance piece

As an alternative to the plastic tube with universal cone, there is also a **distance piece** designed as an all-in-one form-tie distance tube.

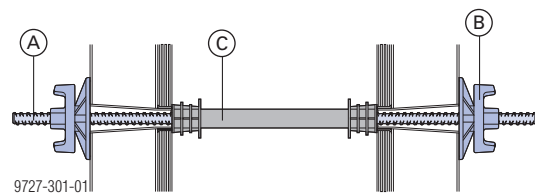

- A** Tie rod 15.0mm
- B** Super plate 15.0
- C** Distance piece (ready for use for certain thicknesses of wall)

The stoppers for plugging the distance pieces are also included.

## The Doka tie rod system 20.0

For high formwork pressures of up to 80 kN/m<sup>2</sup>, use the Tie rod system 20.0.

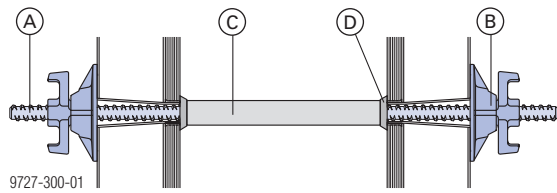

- A Tie rod 20.0mm
- B Super plate 20.0 B
- C Plastic tube 26mm
- D Universal cone 26mm

**Note:**

The Plastic tubes 26mm are left in the concrete and are sealed off with **Plugs 26mm**.

**Tie rod 20.0mm:**

Permitted load-bearing capacity, allowing a 1.6 : 1 factor of safety against failure: 220 kN

Permitted load-bearing capacity to DIN 18216: 160 kN

## Inclined and height-mismatched positioning

Thanks to their large, conical form-tie sleeves, the panels can be inclined on one or both sides, and/or height-mismatched.

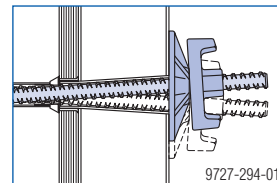

Limit-values when super plates are used		
<b>Conical on 1 side</b>  max. 4°  	<b>Conical on both sides</b>  max. 2 x 4.5°  	<b>Height mismatch</b>  <b>Form-tie system 15.0:</b> max. 1.9 cm per 10 cm of wall thickness <b>Form-tie system 20.0:</b> max. 1.0 cm per 10 cm of wall thickness  

**Note:**

Secure all inclined panels against uplift.  
 Inclined and mismatched positioning are not possible with panels that have been placed on their sides.

## Form-tie situations on the 3.30m panel

The positions of the tie-holes on the 3.30m panels match those on the 2.70m and 1.35m high panels. This means that combinations of these 3 panel heights are possible in both the inside and outside formwork.

- Wall heights of up to 3.30 m possible with no vertical stacking of panels
- Up to a pour height of 3.15 m, only 2 form ties are needed (0.47 ties per m<sup>2</sup>)
- Vertical stacking with horizontal panels possible using 2.70m panels
- Vertical stacking with upright panels possible using all 3 heights of panel

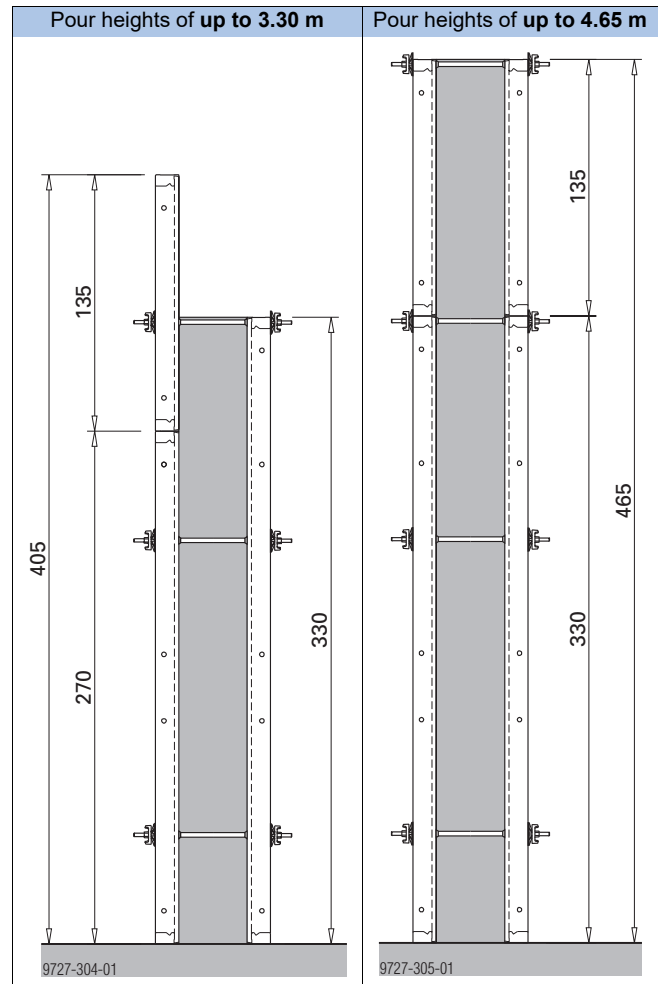
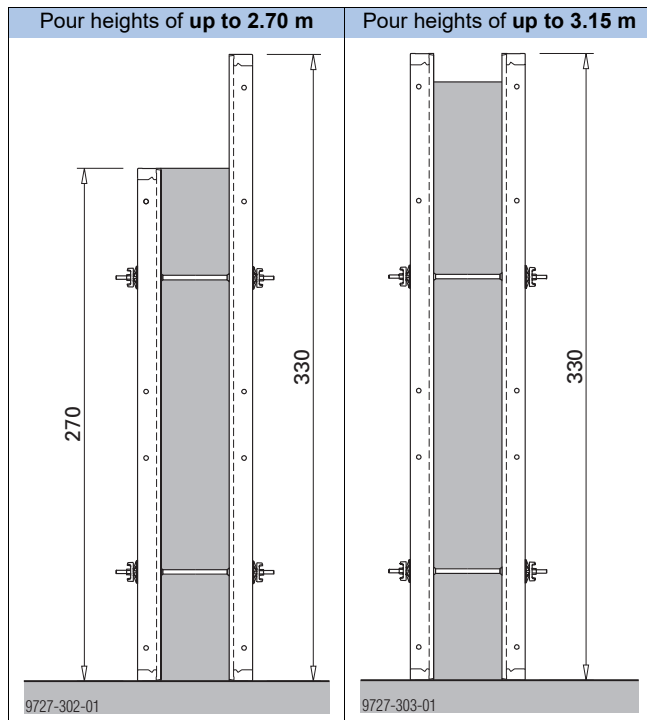

Dimensions in cm

**Note:**

For detailed information on form-tie positions for intermediate heights, see the section headed [Vertical stacking of panels](#).

## Framax head anchor

The Framax head anchor is used for tying Framax Xlife panels.

- The Framax head anchor holds the two sides of the formwork the required distance apart.
- For wall thicknesses from 15 to 100 cm.
- Tension bracing and compression bracing.
- Adjustable in a 5-mm grid.
- When the Framax head anchor is used there is no need for the Doka tie-rod system 15.0 or 20.0 at the following positions:
  - on the top horizontal panel up to a panel width of 0.90m
  - in the top form-tie points of the Framax Xlife panel 3.30m (not vertically stacked)

**Permitted tensile force: 10 kN**  
**Permitted compressive force: 10 kN**

### Assembly:

- ▶ Position the Framax head anchor directly above the form-tie points of the Framax Xlife panel.
- ▶ Telescope the Framax head anchor to the desired length 'a' (= wall thickness) and fix it in the relevant hole with a pin and spring cotter.

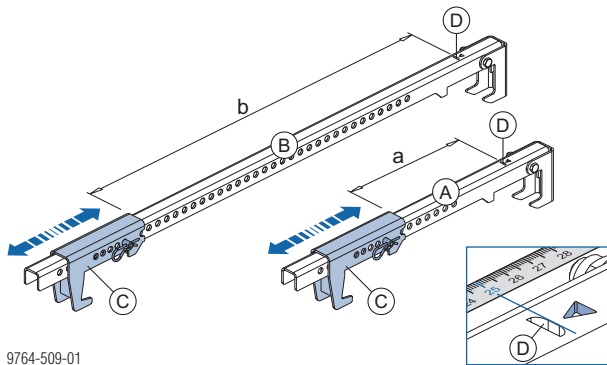

9764-509-01

a ... 15 - 40 cm  
 b ... 15 - 100 cm

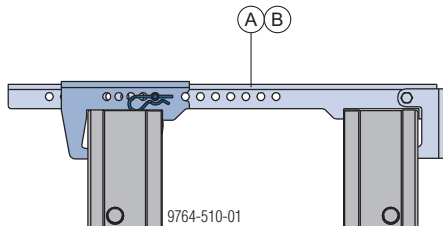

9764-510-01

- A** Framax head anchor 15-40cm
- B** Framax head anchor 15-100cm
- C** Adjusting unit
- D** Notch = measuring point

## Example: Vertical stacking with panel turned long-side horizontal

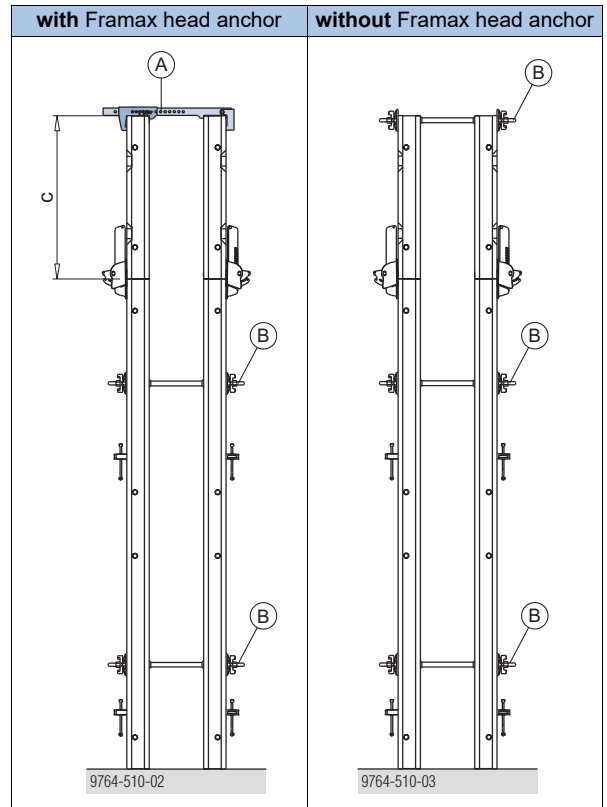

c ... max. 0.90 m

## Example: Framax Xlife panel 3.30m

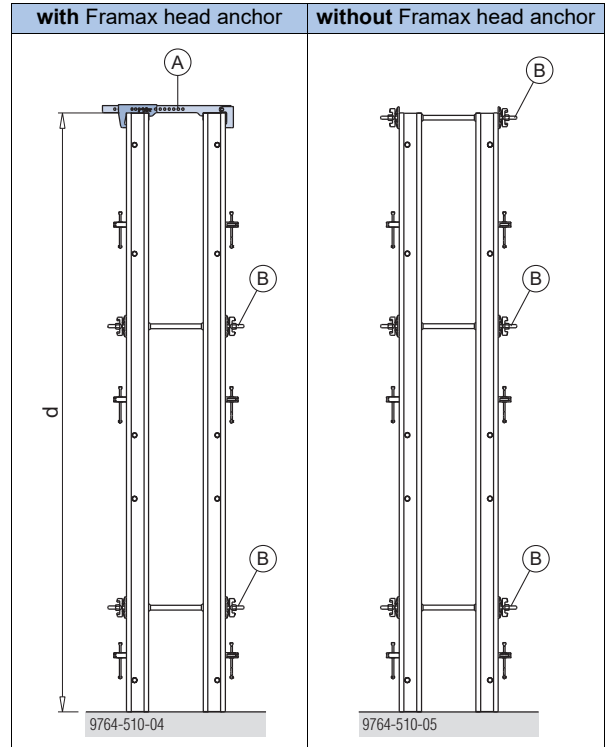

d ... 3.30 m

- A** Framax head anchor
- B** Tie rod system 15.0 and 20.0

# Length adjustment using closures

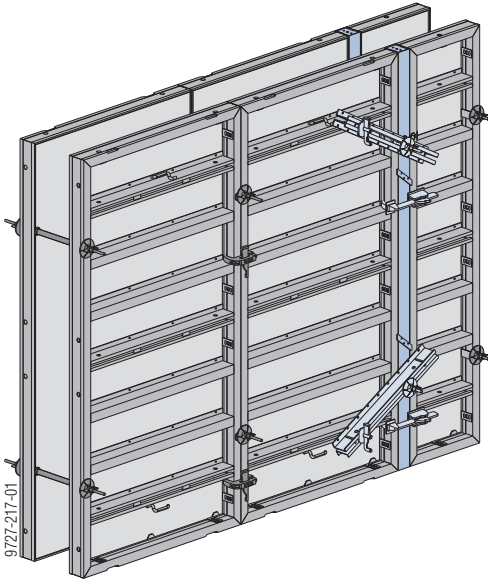

By combining the **Framax alu closures** (5 and 10 cm) and the **Framax fitting timbers** (2, 3, 5 and 10 cm) in various ways, closures can be made in 1 cm increments.

**Example:**

- Closure width = 12 cm
  - 1 Framax alu closure 10cm
  - 1 Framax fitting timber 2cm

**Framax universal waling:**

Permitted moment: 5.2 kNm



Where **space is tight** (e.g. between two Xsafe plus platforms), use the short **Framax universal waling 0.60m**.

## Closures: 0 - 15 cm

### with Framax multi function clamp

#### Tie through frame profile

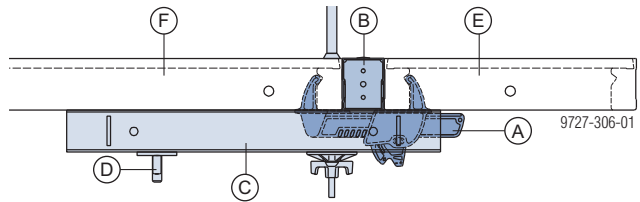

- A Framax multi function clamp
- B Framax alu closure / Framax fitting timber
- C Framax universal waling
- D Framax wedge clamp
- E Framax Xlife panel (max. width 60cm)
- F Framax Xlife panel

#### Tie through enclosure

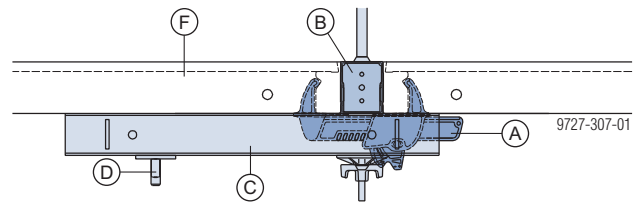

- A Framax multi function clamp
- B Framax alu closure / Framax fitting timber
- C Framax universal waling (for closures of up to 5 cm in width, no universal walings are needed)
- D Framax wedge clamp
- F Framax Xlife panel

### with Framax universal fixing bolt

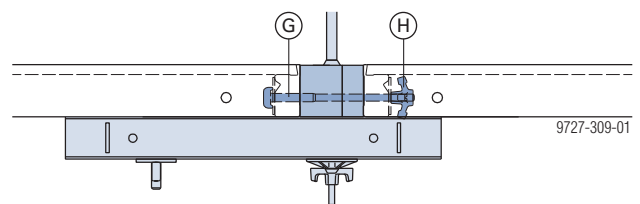

- G Framax universal fixing bolt
- H Star grip nut 15.0 G



**NOTICE**

3 universal fixing bolts are needed per 2.70 m of panel height.

	Closure range
Framax universal fixing bolt 10-16cm	0 to 6 cm
Framax universal fixing bolt 10-25cm	0 to 15 cm

## secured to Framax Xlife panel



### NOTICE

**Be sure to proceed in the correct sequence when stripping the formwork!**

To avoid damage to the alu closure, first strip the panel with the attached closure.

### Framax alu closure

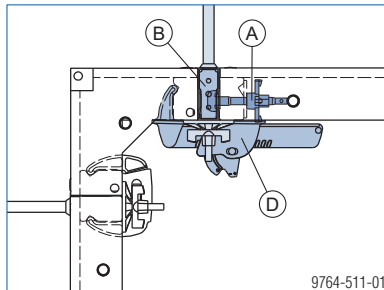

- A Framax clamping bolt 4-8cm + Star grip nut 15.0 G
- B Framax alu closure
- D Framax multi function clamp

### Framax alu closure and Framax fitting timber

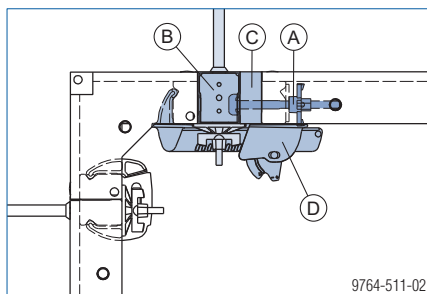

- A Framax universal fixing bolt 10-16cm + Star grip nut 15.0 G \*)
- B Framax alu closure
- C Framax fitting timber <10cm or Framax alu closure 5cm
- D Framax multi function clamp

\*) If (C)  $\leq$  3 cm, use **Clamping screw 4-8cm** instead of the universal fixing bolt.

## Closures: 0 - 20 cm

### with Framax adjustable clamp

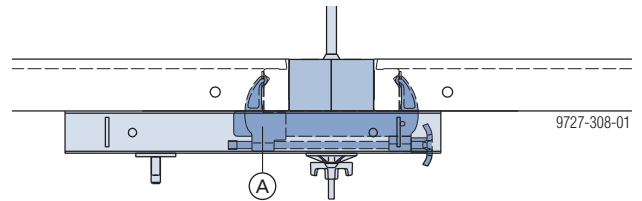

- A Framax adjustable clamp

### Note:

Fit the Framax adjustable clamp in the same position as the Framax multi function clamp

### Framax adjustable clamp:

Permitted tensile force: 10.0 kN

## Closures: 17 - 80 cm

with Framax moulded timber, formwork sheet

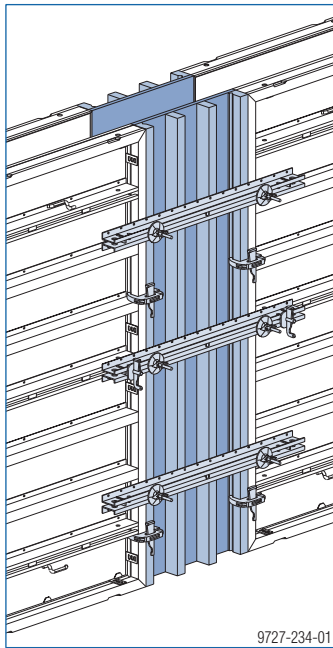

## Closures on horizontal panels

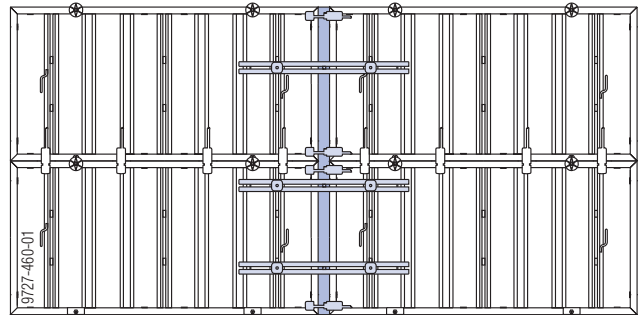

## Closures on 2.40x2.70m panel

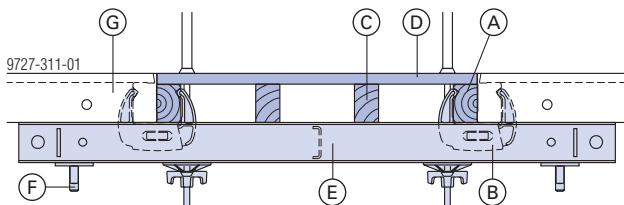
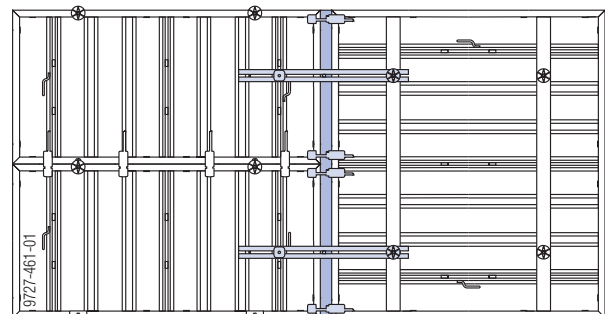

- A Framax moulded timber
- B Framax quick acting clamp RU
- C Squared timber
- D Formwork sheet
- E Framax universal waling
- F Framax wedge clamp
- G Framax Xlife panel

	Infill zone
Framax universal waling 0.90m	0 to 30 cm
Framax universal waling 1.50m	0 to 80 cm

### ! NOTICE

#### Tying the panels:

- Closure widths <30 cm: fix 1 form tie through the closure in the top and bottom universal waling.
- Closure widths >30 cm: fix two ties in each of the 3 universal walings (per 2.70 m formwork height).
- A tension anchor can be made using a tie rod and Star grip nut 15.0 G.

# 90 degree corners

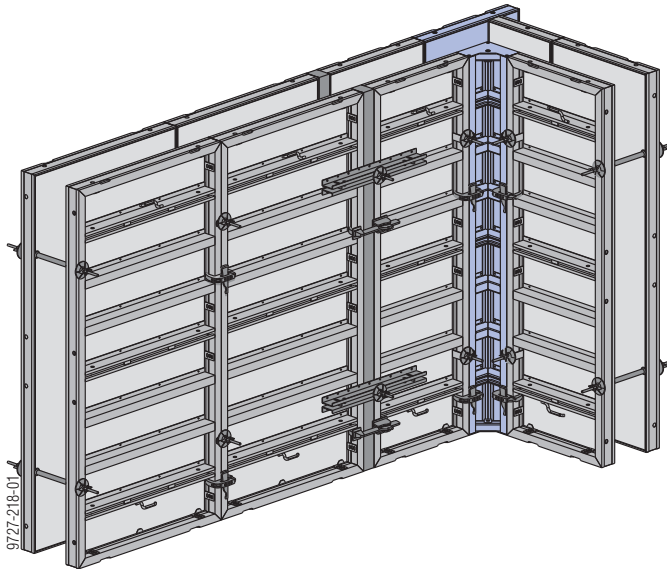

The corner solutions are based on the strong, torsionally rigid **Framax Xlife inside corner**.

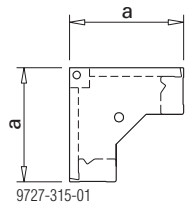

a ... 30 cm

The hole drilled in the inside corner enables a vertical stacking connection to be made using universal fixing bolts + super plates.

There are **2 ways** of forming right-angled **outside corners**:

- with a Framax Xlife universal panel
- with a Framax outside corner

**Note:**

For details regarding extra inter-panel connections on outside corners (for increased tensile loads) see the section headed [Inter-panel connections for increased tensile loads](#).

## with Framax Xlife universal panels

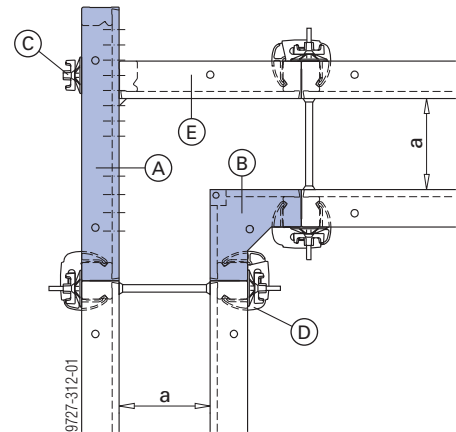

a ... 30 cm

- A** Framax Xlife universal panel
- B** Framax Xlife inside corner
- C** Framax universal fixing bolt + Super plate 15.0
- D** Framax quick acting clamp RU
- E** Framax Xlife panel (max. width 90cm)

**Required numbers of universal fixing bolts + Super plates 15.0:**

Universal panel 0.90m	2
Universal panel 1.35m	2
Universal panel 2.70m	4
Universal panel 3.30m	5



If the **entire outside corner** is raised and repositioned by crane, then **no universal walings** are needed for height-bracing the panels.

**Note:**

Seal off the unused holes in the formwork sheet of the universal panels with **Framax plugs R 24.5**.

### Framax Xlife universal panel 0.90m

Different wall-thickness grids (5 and 6 cm) are possible by installing the 0.90 m wide universal panel upside down.

**Exception:**

Panel height 3.30 m: continuous 5 cm hole grid (upside-down use of panel not possible)

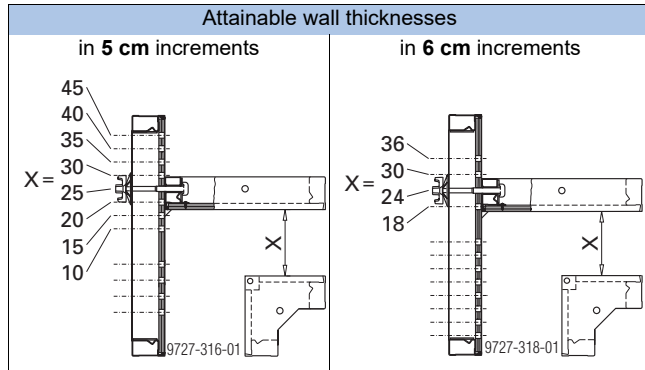

### Framax Xlife universal panel 1.20m

The continuous 5 cm hole-grid makes it possible to form corner configurations on walls of up to 75 cm thick.

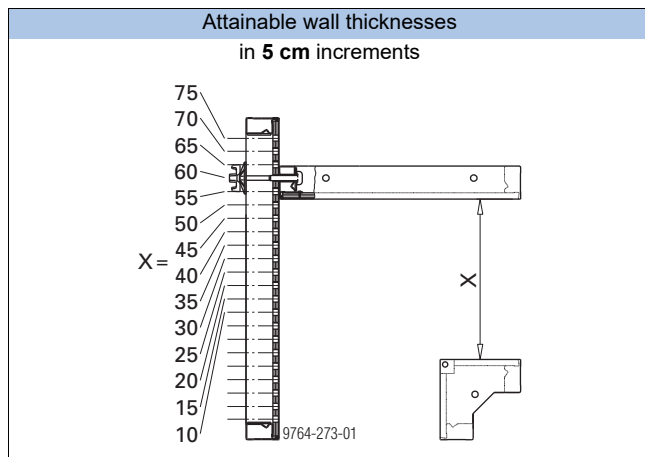

### with Framax outside corner

The Framax outside corner is an easy way of forming corners in narrow trench situations or where large wall thicknesses are called for.

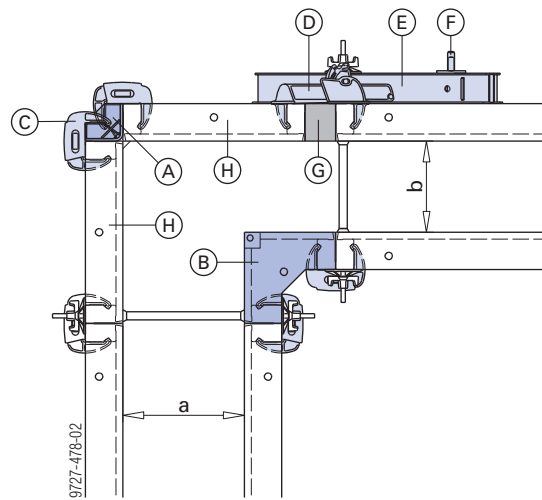
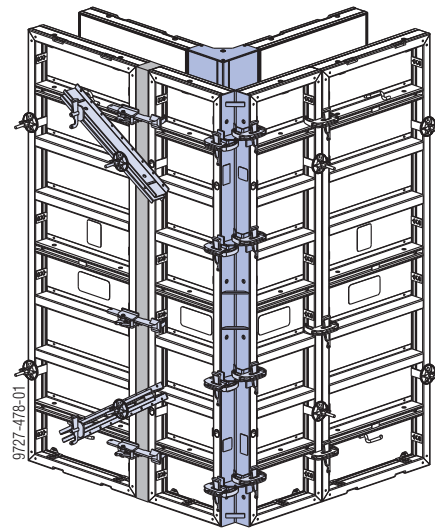

a ... 40 cm  
b ... 30 cm

- A** Framax outside corner
- B** Framax Xlife inside corner
- C** Framax quick acting clamp RU
- D** Framax multi function clamp
- E** Framax universal waling
- F** Framax wedge clamp
- G** Fitting-timber
- H** Framax Xlife panel (max. width 90cm)

**Required number of connectors for different fresh-concrete pressures and wall thicknesses:**

Pressure of fresh concrete $P_k$	Wall thickness	Height of outside corner	Quick acting clamp RU	Tensioning wedge + wedge bolt	
60 kN/m <sup>2</sup>	up to 40 cm	1.35m	4	-	
		2.70m	8	-	
		3.30m	10	-	
	> 40 and up to 75 cm	1.35m	-	4	-
		2.70m	-	8	-
		3.30m	-	10	-
80 kN/m <sup>2</sup>	up to 25 cm	1.35m	4	-	
		2.70m	8	-	
		3.30m	10	-	
	> 25 and up to 60 cm	1.35m	-	4	-
		2.70m	-	8	-
		3.30m	-	10	-

**Example: T-junction**

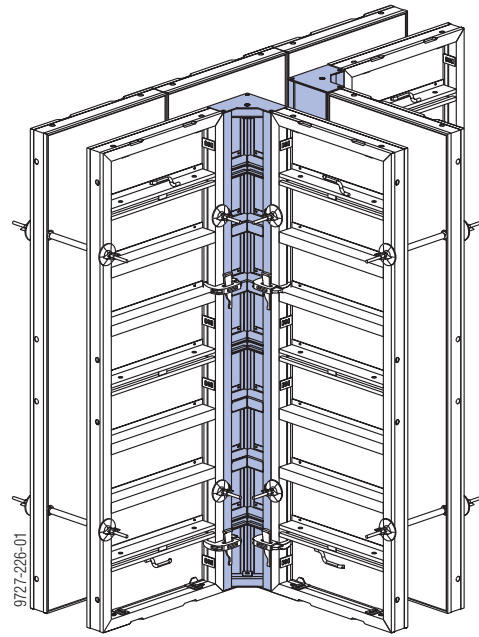

**Wedge bolt and tensioning wedge:**

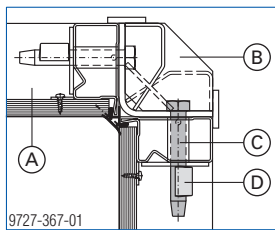

- A Framax Xlife panel
- B Framax outside corner
- C Framax wedge bolt RA 7.5
- D Framax tensioning wedge R



**NOTICE**

Do not oil or grease wedged connections.



When there is a **closure on both sides** of the inside corner, bracing can be achieved economically with the **universal corner waling**.



**NOTICE**

When striking the formwork, separate the gang-form at the Framax outside corner (remove the connectors on one side of the Framax outside corner).

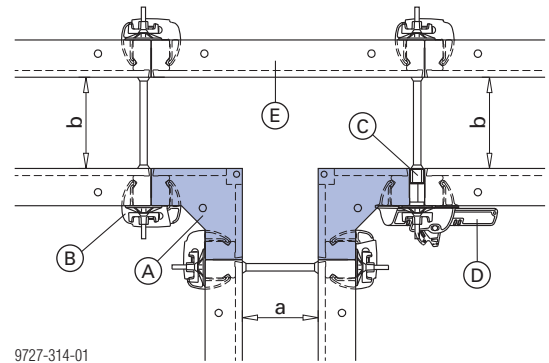

a ... 25 cm  
b ... 30 cm

- A Framax Xlife inside corner
- B Framax quick acting clamp RU
- C Framax aluminium closure
- D Framax multi function clamp
- E Framax Xlife panel 0.90m

# Pilasters

**Framax Xlife pilaster panels** are used for the non-tied forming of pilasters.

Product features:

- No need for ties through the pilaster.
- The integral folding function makes the stripping procedure faster.
- Depending on the stop-end used, pilasters up to 60 cm deep and 60 cm wide are possible.
- Panel heights:
  - 1.35 m
  - 3.30 m<sup>\*)</sup>

<sup>\*)</sup> for Connecting panel 2.70m or 3.30m

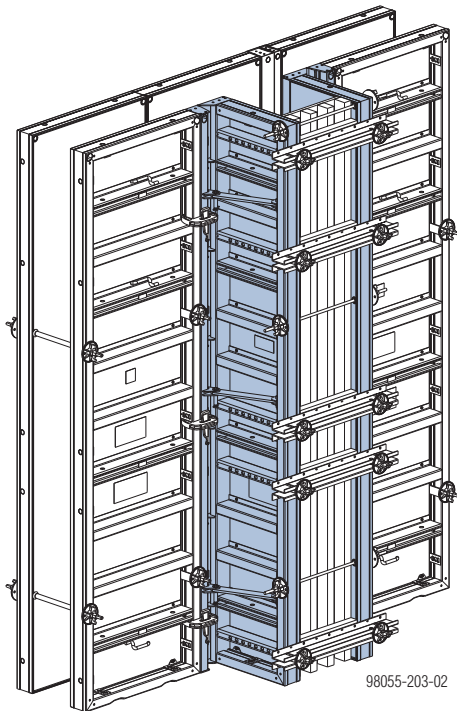

98055-203-02

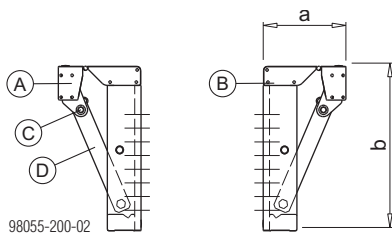

98055-200-02

a ... 30 cm  
b ... 60 cm

- A** Framax Xlife pilaster panel 3.30m or 1.35m left
- B** Framax Xlife pilaster panel 3.30m or 1.35m right
- C** Fastening bolt for fixing at right-angles
- D** Lug

### Required number of connectors per stop-end:

Panel height	Framax universal fixing bolt + Super plates 15.0
1.35m	4
3.30m	10

### Example of stop-end with universal waling

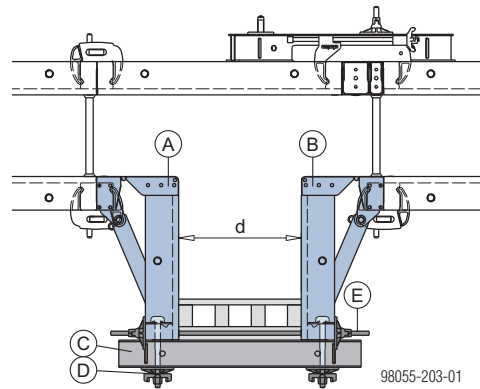

98055-203-01

d ... max. 60 cm

- A** Framax Xlife pilaster panel left
- B** Framax Xlife pilaster panel right
- C** Framax universal waling
- D** Framax universal fixing bolt + Super plate 15.0
- E** Doka tie rod system

### Example of stop-end with Framax Xlife panel

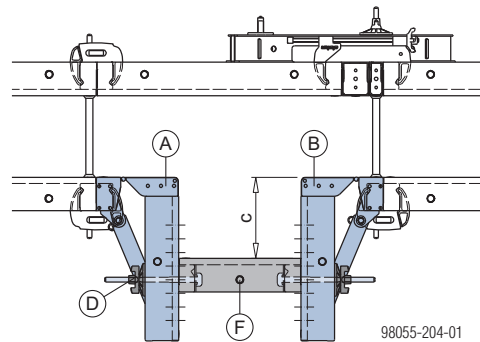

98055-204-01

c ... 10 to 45 cm, in 5 cm increments  
(or 60 cm with universal panel as stop-end)

- A** Framax Xlife pilaster panel left
- B** Framax Xlife pilaster panel right
- D** Framax universal fixing bolt + Super plate 15.0
- F** Framax Xlife panel 0.45m or 0.60m

### Example of short corner connection

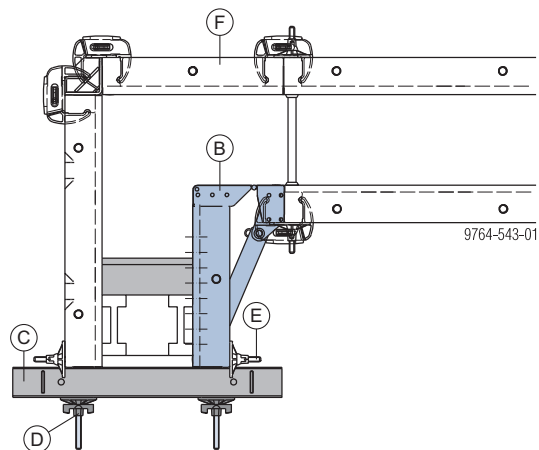

9764-543-01

- B** Framax Xlife pilaster panel right
- C** Framax universal waling
- D** Framax universal fixing bolt + Super plate 15.0
- E** Doka tie rod system
- F** Framax Xlife panel 0.60m

## Opening the formwork

- ▶ Remove the stop-end formwork.

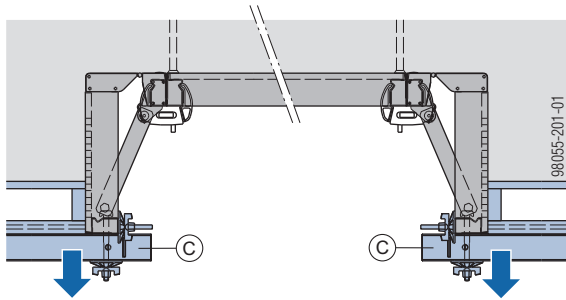

**C** Stop-end formwork

- ▶ Take out the fastening bolt and swivel the lug inward.

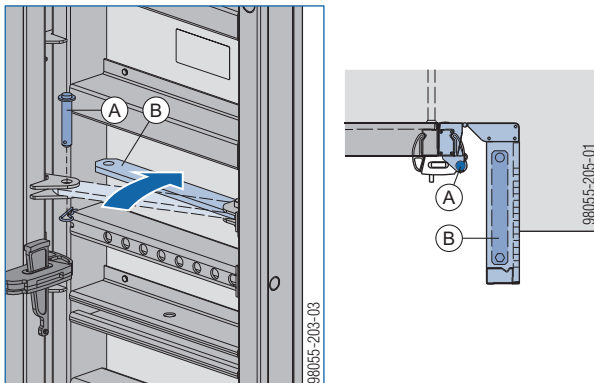

**A** Fastening bolt

**B** Lug

- ▶ Swivel pilaster panels inward.

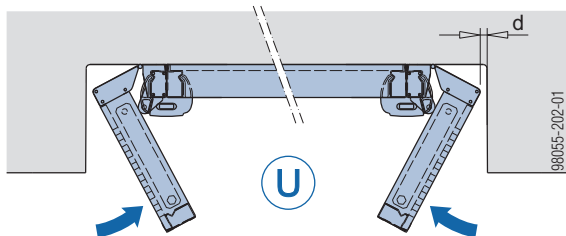

d ... formwork-striking play 2.5 cm

**U** Unit for repositioning

- ▶ Detach the entire unit from the concrete and crane-lift it to the next position.

## Edges

### with Framax frontal triangular ledge

The Framax frontal triangular ledge can be slipped over the front end of the panel without being nailed and is used with the universal panel to form outside corners (integral slot grid for universal fixing bolts). It is also possible to form edges using the Framax triangular ledge, of course.

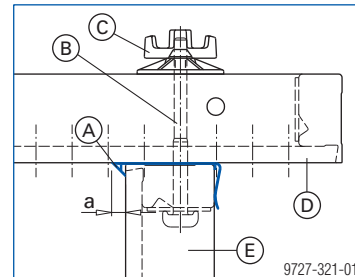

a ... 20 mm

**A** Framax frontal triangular ledge or Framax triangular ledge 2.70m

**B** Framax universal fixing bolt

**C** Super plate 15.0

**D** Framax Xlife universal panel

**E** Framax Xlife panel

### with the Framax triangular ledge

Where outside corners are formed using the Framax outside corner, the Quick acting clamps used for the interconnection mean that the Framax triangular ledge has to be used.

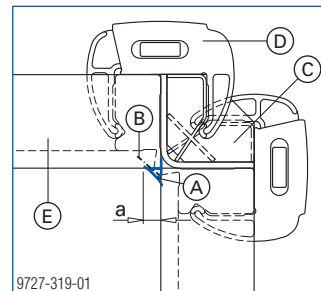

a ... 20 mm

**A** Framax triangular ledge 2.70m

**B** Wire nail 22x40

**C** Framax outside corner

**D** Framax quick-acting clamp RU

**E** Framax Xlife panel

# Acute & obtuse-angled corners

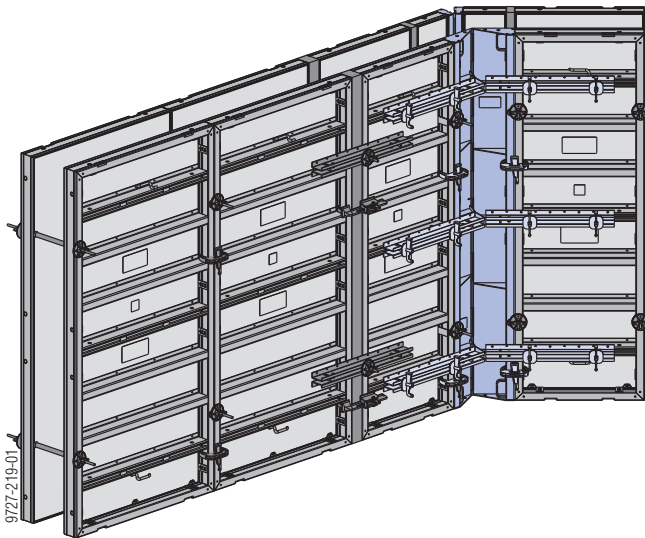

**Note:**

For angles of less than 120°, no universal walings are needed in inside corners.



**NOTICE**

With closures, provide additional universal walings in accordance with the section headed [Length adjustment using closures](#).

**Number of clamps needed in the hinged outside corner:**

Panel height	Number of clamps
1.35 m	4
2.70 m	8
3.30 m	10



**NOTICE**

For details regarding extra inter-panel connections on outside corners (for increased tensile loads) see the section headed [Inter-panel connections for increased tensile loads](#).

Acute and obtuse angles are solved using the hinged inside and outside corners.

Hinged inside corner I (powder-coated)	Hinged inside corner I galvanised
<p>9727-323-01</p> <p>a ... 0.7 cm b ... 29.2 cm</p>	<p>9783-317-01</p> <p>a ... 0.7 cm b ... 29.3 cm</p>

Hinged outside corner A (powder-coated)	Hinged outside corner A galvanised
<p>9727-322-01</p> <p>a ... 5.5 cm b ... 0.8 cm</p>	<p>9783-318-01</p> <p>a ... 6.3 cm</p>

**Note:**

The Framax hinged outside corner A galvanised cannot be combined with the Framax hinged outside corner A (powder-coated).

**Number of universal walings in outside and inside corners:**

Panel height	Number of universal walings
1.35 m	4
2.70 m	6
3.30 m	8

Position of the universal walings:

In every support level of the Hinged inside corner I.

## 70° (60°) - 135° angles, with hinged corners I + A

Pressure of fresh concrete $P_k$	Max. width of panel next to Hinged outside corner A
60 kN/m <sup>2</sup>	90 cm
80 kN/m <sup>2</sup>	60 cm
In addition, closures of up to max. 15 cm are allowed.	

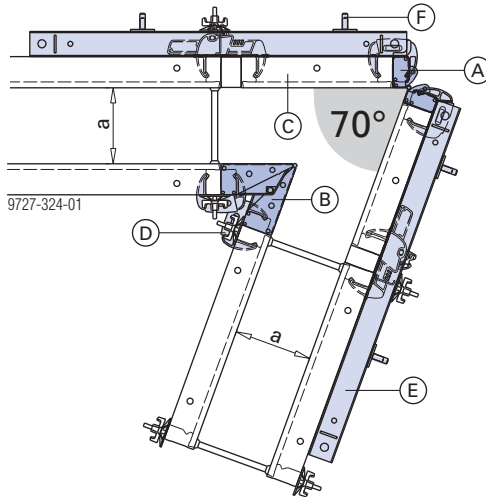

a ... 30 cm

- A Framax hinged outside corner A
- B Framax hinged inside corner I
- C Framax Xlife panel 0.60m
- D Framax quick-acting clamp RU
- E Framax universal waling 1.50m
- F Framax wedge clamp

Where **universal fixing bolts** are used instead of the quick-acting clamp RU in the inside corner, an angle of **60°** is also possible.

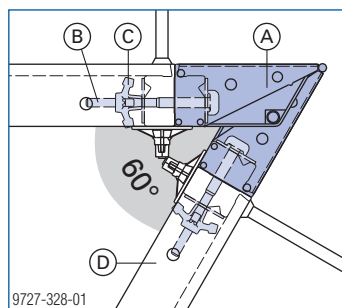

- A Framax hinged inside corner I
- B Framax universal fixing bolt
- C Star grip nut 15.0 G
- D Framax Xlife panel

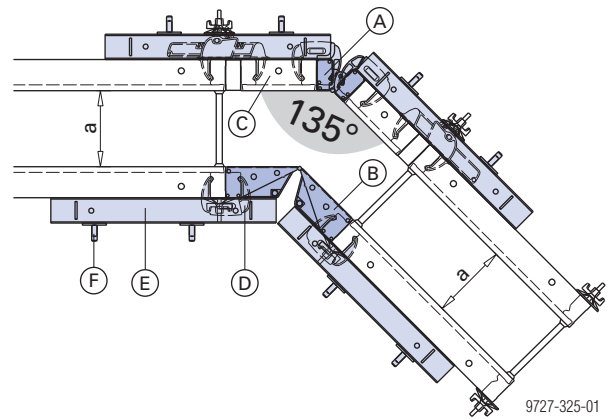

a ... 30 cm

- A Framax hinged outside corner A
- B Framax hinged inside corner I
- C Framax Xlife panel 0.30m
- D Framax quick-acting clamp RU
- E Framax universal waling
- F Framax wedge clamp

## 90° - 180° angles, with hinged inside corner I only

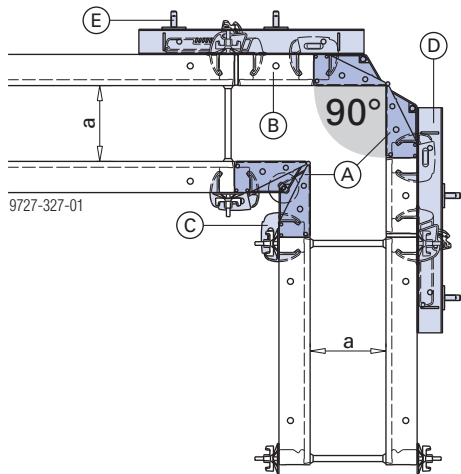

a ... 30 cm

- A** Framax hinged inside corner I
- B** Framax Xlife panel 0.30m
- C** Framax quick acting clamp RU
- D** Framax universal waling
- E** Framax wedge clamp

The hinged inside corner I can be fixed at an angle of 90° using universal fixing bolts and Super plates 15.0.

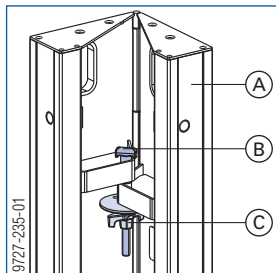

- A** Framax hinged inside corner I
- B** Framax universal fixing bolt
- C** Super plate 15.0

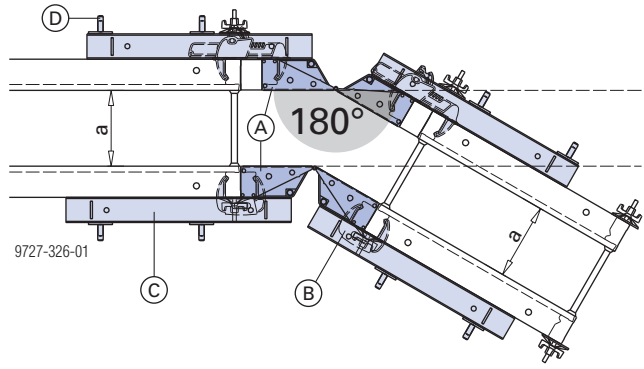

a ... 30 cm

- A** Framax hinged inside corner I
- B** Framax quick acting clamp RU
- C** Framax universal waling
- D** Framax wedge clamp

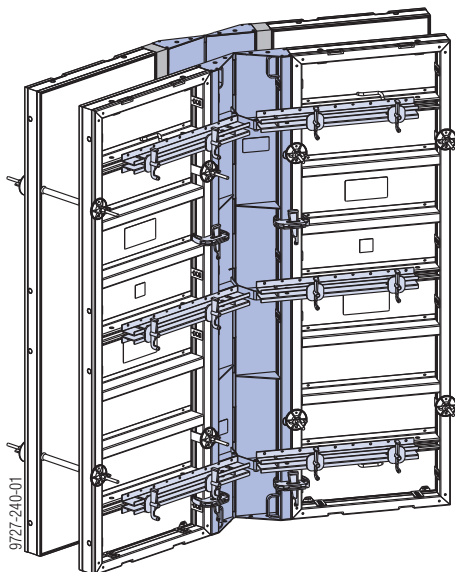

# Shaft formwork

## Framax stripping corner I

The **Framax-stripping corner I** is used to form right-angled inside corners in the shaft.

With it, the entire shaft formwork unit is detached from the wall in one piece and then repositioned by crane.

Product features:

- No negative impression in the concrete.
- Formwork set-up and stripping function integrated in the inside corner.
- The entire shaft formwork is repositioned in one piece.

The possibilities for setting up and stripping the formwork are as follows:

- Framax stripping spindle I
- Framax stripping spindle I with ratchet
- Framax stripping cylinder I (hydraulic)

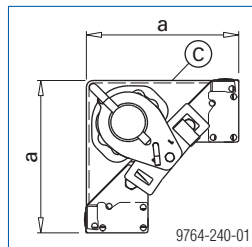
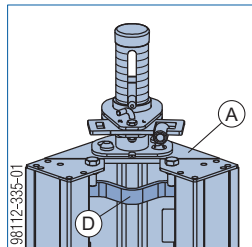
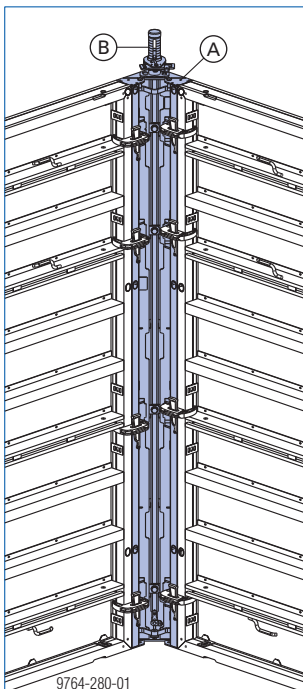

a ... 30.0 cm

**Position of closures (fitting-timbers) in the inside shaft formwork:**

- whenever possible, not directly next to the stripping corners

**Formwork-stripping clearance:**

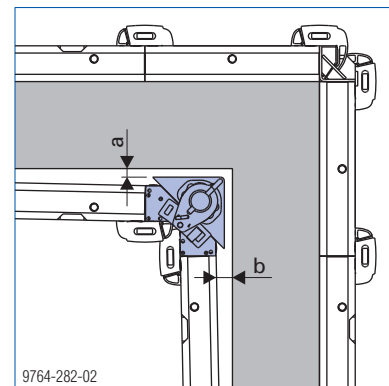
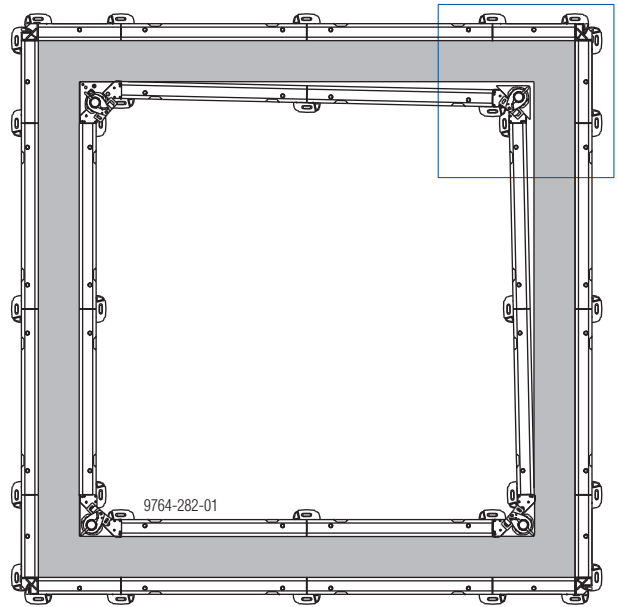

a ... 3.0 cm  
b ... 6.0 cm

- A** Framax stripping corner I
- B** Framax stripping spindle I or Framax stripping spindle I with ratchet or Framax stripping cylinder I
- C** Steel form-facing
- D** Slinging point (to be used exclusively for lifting **only one** stripping corner on its own!)

### Required number of Framax quick acting clamps RU:

Height of the stripping corner I	Number of clamps
1.35 m	4
2.70 m	6
3.30 m	8

### Note:

In order to obtain the full available stripping-play, make sure that the Framax quick acting clamps RU are mounted at staggered heights (i.e. not opposite one another).

## Vertical stacking of Framax stripping corners I

- Connect the bottom stripping corner to the framed formwork panel.
- Pull the coupling bolt out of the top stripping corner.
- Remove the two hexagon bolts from the bottom stripping corner.
- Engage the top stripping corner flush on the bottom stripping corner.
- Push the coupling bolt back in.
- Bolt the stripping corners together with the 2 hexagon bolts and hexagon nuts removed beforehand.
- Vertically stack the next framed formwork panel and connect it to the stripping corner.

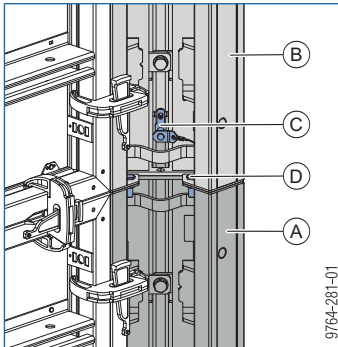

- A Bottom stripping corner I
- B Top stripping corner I
- C Coupling bolt
- D Hexagon bolt ISO 4019 M16x45 8.8 galv. +  
Hexagon nut ISO 4032 M16 8 galv.

Animation: <https://player.vimeo.com/video/256373947>

## Operating the Framax stripping corner I with stripping spindle

### Assembly

These assembly instructions apply to both **Stripping spindles I** and **Stripping spindles I with ratchet**.

- 1) Pull out the U-bolt from the stripping spindle.
- 2) Place the stripping spindle on the centring stud of the stripping corner.
- 3) Turn the stripping spindle clockwise until fully engaged.
- 4) Position the ratchet or spindle nut between the holes in the push rod.
- 5) Fix the stripping spindle with the U-bolt.

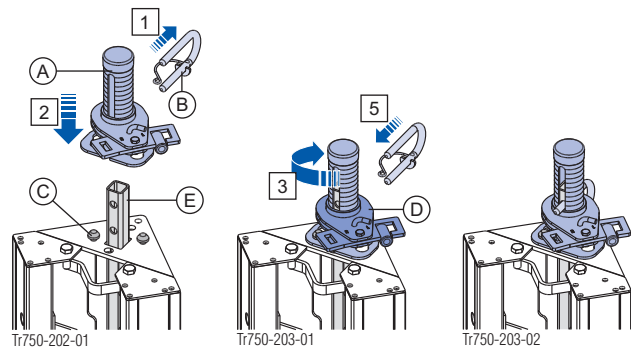

- A Framax stripping spindle I or  
Framax stripping spindle I with ratchet
- B U-bolt
- C Centring stud of stripping corner
- D Ratchet or spindle nut
- E Push rod

Animation:

<https://player.vimeo.com/video/256374622>

## Operating the Framax stripping spindle I with ratchet

- ▶ Screw a Tie-rod 15.0mm into the Weldable coupler 15.0 of the ratchet.
- ▶ **Setting up:**
  - shift the change-over lever into the 'L' position
  - turn the ratchet **clockwise**
- ▶ **Stripping:**
  - shift the change-over lever into the 'R' position
  - turn the ratchet **anti-clockwise**.

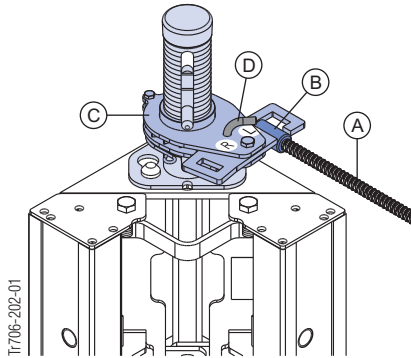

- A Tie-rod 15.0mm
- B Weldable coupler 15.0
- C Ratchet
- D Change-over lever

## Operating the Framax stripping spindle I

- ▶ Push a Tie rod 15.0mm through one of the holes in the spindle nut.
- ▶ **Setting up:** Twist the spindle nut **clockwise**.
- ▶ **Stripping:** Twist the spindle nut **anti-clockwise**.

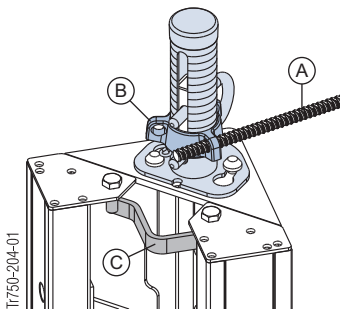

- A Tie rod 15.0mm
- B Spindle nut
- C Slinging point (to be used exclusively for lifting **only one** stripping corner on its own!)

## Operation of the Framax stripping corner I hydraulic

With the **Framax stripping cylinder I**, formwork up to 5.40 m high can be erected and stripped hydraulically.

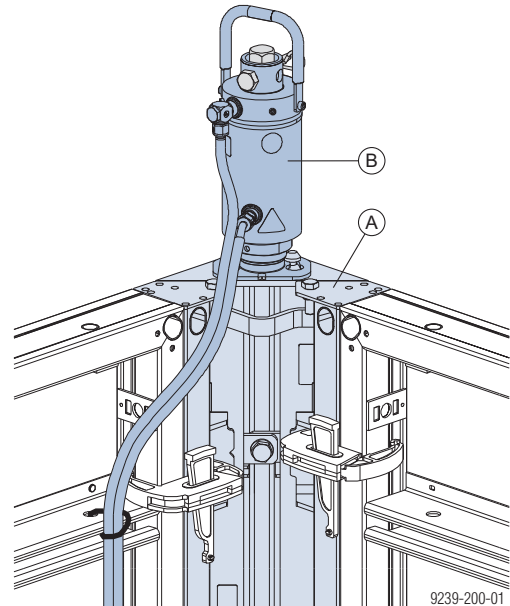

- A Framax stripping corner I
- B Framax stripping cylinder I



### NOTICE

It is not permissible to install the stripping cylinder on a stripping corner that does not have a hole for the locking pin!

This hole is a standard feature of all stripping corners manufactured from 2005 onward.

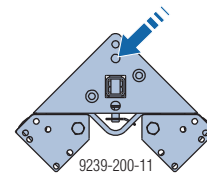

Depending on requirements, the Framax stripping cylinder I can be used with various hydraulic units and accessories.

### Compatible hydraulic units

- Battery hydraulic unit V2.5 200bar DA
- Hydraulic unit Framax V4 with
  - Cordless screwdriver 18 V (1800 rotation/min)
- Hydraulic unit V45 50/60Hz with
  - System pressure controller Xclimb 60 V45
- Hydraulic unit SCP V1200 50/60Hz with
  - Coupling adapter Framax stripping cylinder I



Follow the directions in the 'Framax stripping corner I hydraulic' Operating Instructions!

## Lifting by crane

### Framax lifting hook

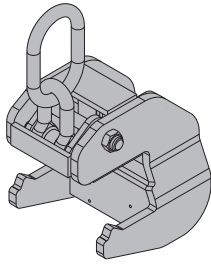

Follow the Operating Instructions!

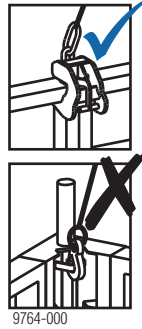
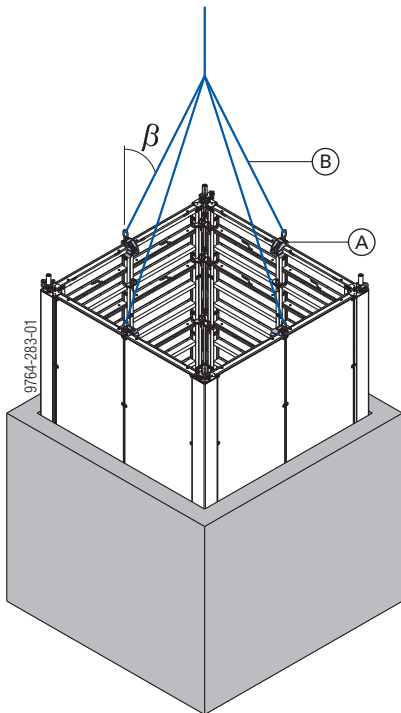

$\beta$  ... max. 15°

- A Framax lifting hook
- B Four-part lifting chain



Do not use the slinging point on the Stripping corner I for lifting the shaft formwork.

► The shaft formwork **may only be reset using lifting hooks.**

**Permitted weight of the shaft formwork:**  
4000 kg with 4 Framax lifting hooks



Use a lifting beam for repositioning large gang-forms.

## Facilitating stripping with the stripping timber

The diagonally cut stripping timber makes quick work of striking inside-formwork in narrow cross-sections such as lift-shafts or stair-wells.

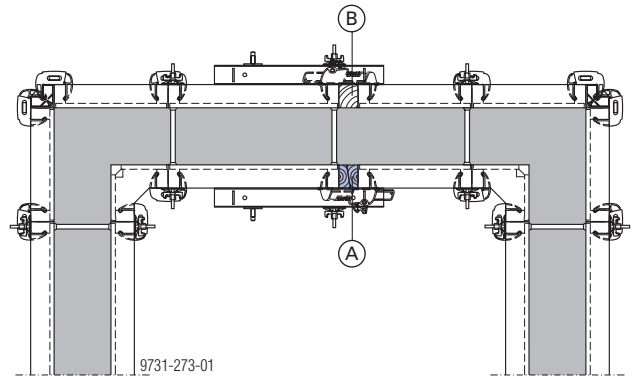

- A Inside - stripping timber
- B Outside - fitting timber

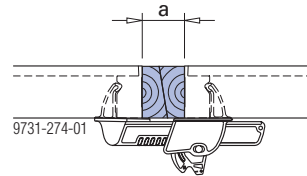

a ... 10 cm

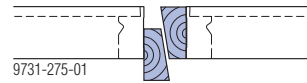

The Framax stripping timber is available in lengths of 2.85 m. The stripping timbers thus project 15 cm beyond the ends of the panels, and so are easier to remove.

## Inter-panel connections for increased tensile loads

As a rule, only **2 clamps** are needed per **2.70 m** and **3 clamps** per **3.30 m** formwork height as a tension link between the panels.

However, where **increased tensile loads** need to be sustained near outside corners and stop-ends, **extra inter-panel connectors are needed**.

### Wall thickness up to 40 cm:

- For each inter-panel joint up to 1.35 m
  - 1 additional clamp

### Wall thickness up to 60 cm:

- For each inter-panel joint up to 1.35 m
  - 2 additional clamps
- For each inter-panel joint between 1.35 m and 2.70 m
  - 1 additional clamp

### Wall thickness up to 75 cm:

- For each inter-panel joint up to 1.35 m
  - 3 additional clamps
- For each inter-panel joint between 1.35 m and 2.70 m
  - 2 additional clamps
- For each inter-panel joint between 2.70 m and 4.05 m
  - 1 additional clamp

## Near stop-ends

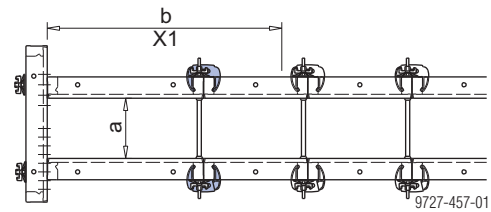

a ... up to 40 cm

b ... 1.35 m

**X1 ... 1 extra clamp**

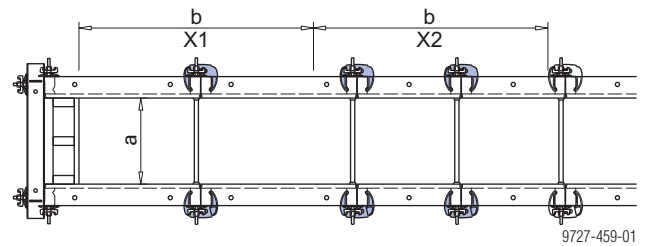

a ... up to 60 cm

b ... 1.35 m

**X1 ... 2 extra clamps**

**X2 ... 1 extra clamp**

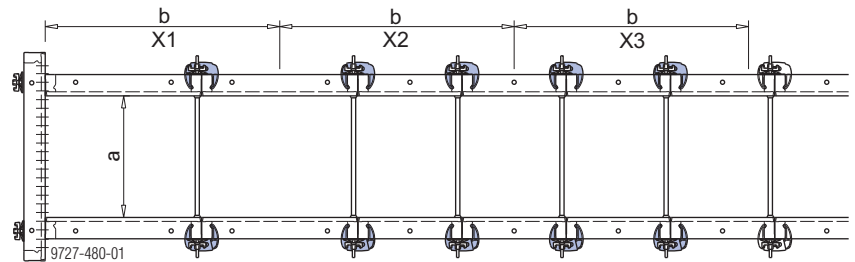

a ... up to 75 cm

b ... 1.35 m

**X1 ... 3 extra clamps**

**X2 ... 2 extra clamps**

**X3 ... 1 extra clamp**

## Near outside corners

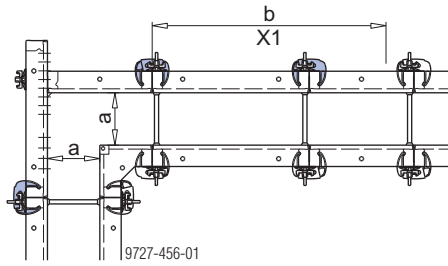

a ... up to 40 cm

b ... 1.35 m

X1 ... 1 additional clamp

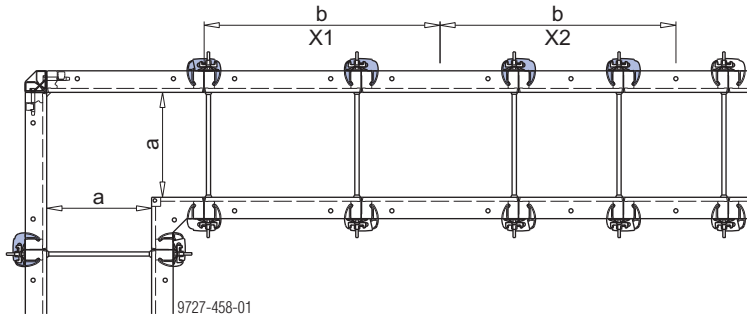

a ... up to 60 cm

b ... 1.35 m

X1 ... 2 additional clamps

X2 ... 1 additional clamp

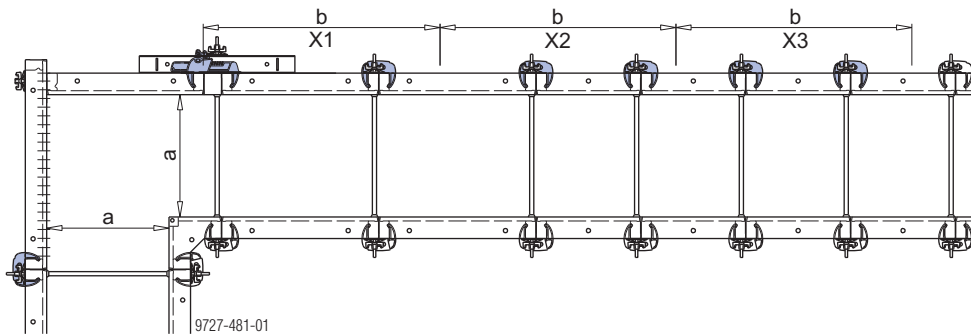

a ... up to 75 cm

b ... 1.35 m

X1 ... 3 additional clamps

X2 ... 2 additional clamps

X3 ... 1 additional clamp



### NOTICE

For a fresh-concrete pressure  $P_k$  of **over 60 kN/m<sup>2</sup>** or wall thicknesses of **over 40 cm**, **wedge bolts** and **tensioning wedges** must be used in the outside corners instead of quick acting clamps (see the section headed [90 degree corners](#)).

## Stop-end formwork

There are **3 ways** of forming **stop-ends**:

- with universal waling
- with stop-end waler tie
- with universal panel

**Note:**

For details regarding extra inter-panel connections on stop-ends (for increased tensile loads) see the section headed [Inter-panel connections for increased tensile loads](#).

### with universal panels

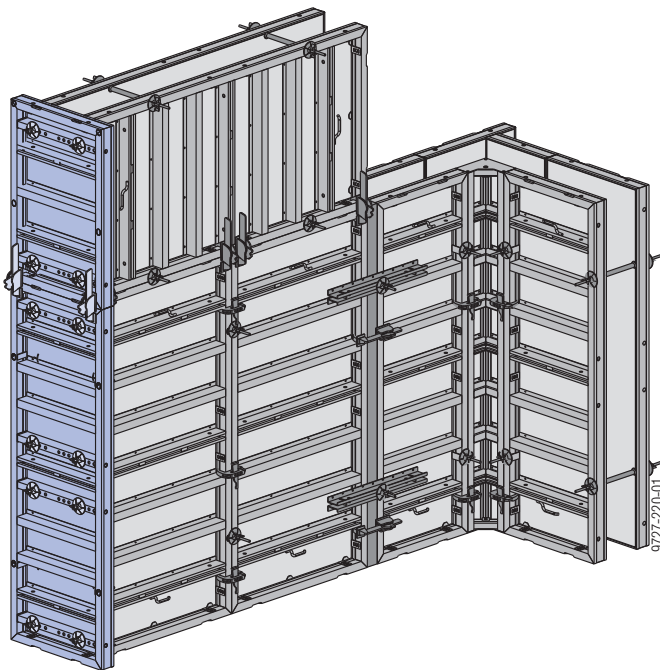

The universal panels are mounted using universal fixing bolts and Super plates 15.0.

**Required numbers of universal fixing bolts + Super plates 15.0:**

Universal panel 0.90m	4
Universal panel 1.35m	4
Universal panel 2.70m	8
Universal panel 3.30m	10

**Note:**

Seal off the unused holes in the formwork sheet of the universal panels with **Framax plugs R 24.5**.

### Framax Xlife universal panel 0.90m

#### Universal panel 0.90m, 1.35m and 2.70m

The stop-end formwork can be **flexibly adapted to different wall thicknesses** by the two integrated hole-grids.

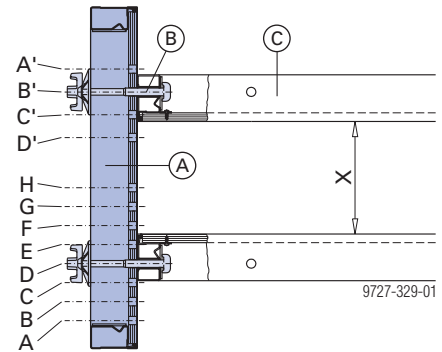

- A** Framax Xlife universal panel 0.90m
- B** Framax universal fixing bolt + Super-plate 15.0
- C** Framax Xlife panel (panel width > 0.30m)

Combination	Wall thickness X	
A' with H to A	16 to 51 cm	in 5 cm increments
B' with H to A	10 to 45 cm	
C' with H to A	4 to 39 cm	
D' with G to A	3 to 33 cm	

#### Universal panel 3.30m

The continuous **5 cm hole-grid** makes it possible to form stop-ends on walls of **up to 60 cm thick**.

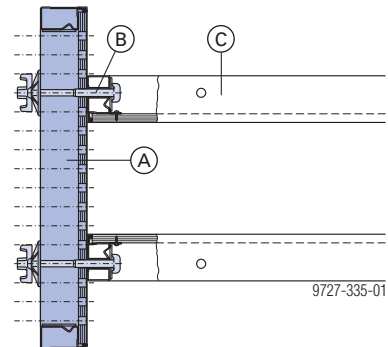

- A** Framax Xlife universal panel 0.90x3.30m
- B** Framax universal fixing bolt + Super-plate 15.0
- C** Framax Xlife panel (panel width > 0.30m)

## Framax Xlife universal panel 1.20m

The continuous **5 cm hole-grid** makes it possible to form stop-ends on walls of **up to 75 cm thick**.

**Note:**

If the concrete pressure is reduced, wall thicknesses of up to 90 cm are also possible.

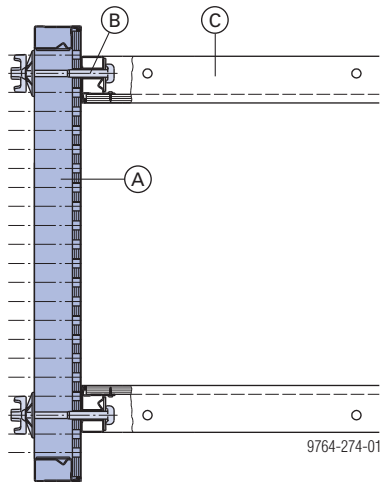

- A Framax Xlife universal panel 1.20m
- B Framax universal fixing bolt + Super-plate 15.0
- C Framax Xlife panel (panel width > 0.30m)

## with stop-end waler ties

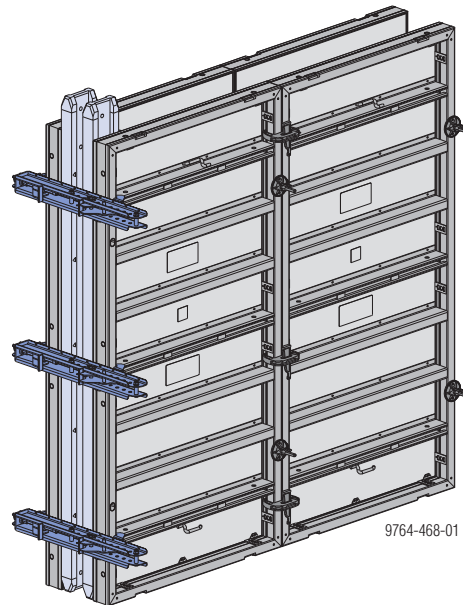

The stop-end waler ties make it possible to form stop-ends continuously from wall thicknesses of 15 cm to 75 cm.

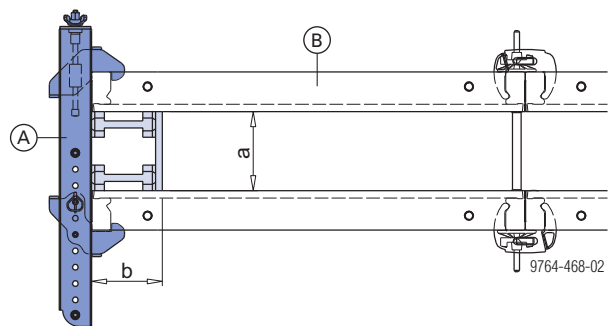

- a ... 15 to 75 cm
- b ... ≥ 20 cm (only statically necessary on panel width 1.35m)

- A Framax stop-end waler tie
- B Framax Xlife panel

**Position of stop-end waler tie:**

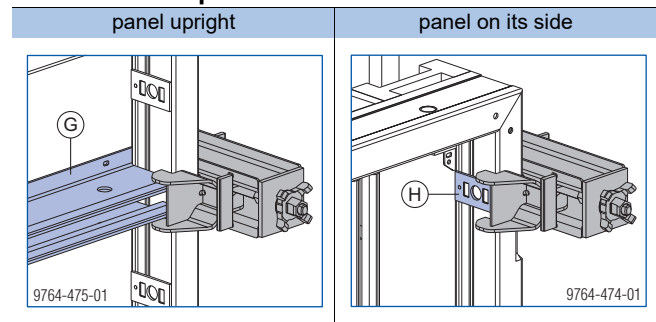

- G Cross profile
- H Cross-borehole plate

**Assembly:**

- Fix the required wall thickness with twin pins.
- Position the stop-end waler tie on the formwork.
- Fine-adjust the screwjack clamp with the star grip nut, and tighten it.

**Stop-end waler tie  
15-45cm**

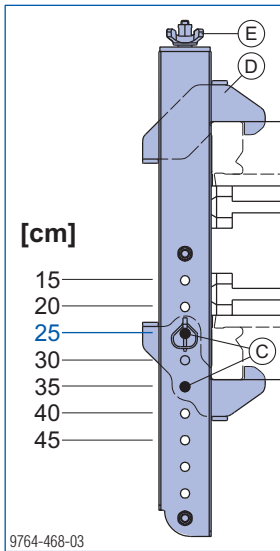

**Stop-end waler tie  
15-75cm**

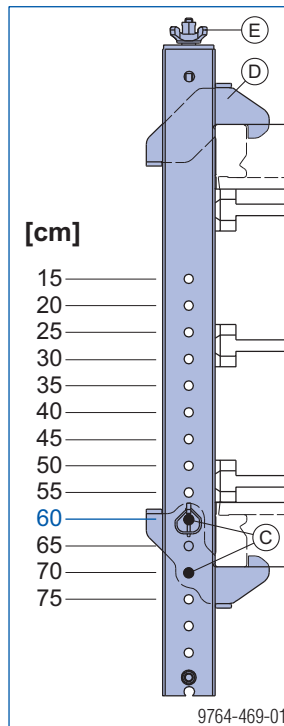

- C** Twin pins
- D** Screwjack clamp
- E** Star grip nut

**Required numbers of Framax stop-end waler ties**

**Panels upright:**

Panel height	Fresh-concrete pressure $P_k$ 60 kN/m <sup>2</sup>	
	2.70m	3.30m
Wall thickness 15-45cm:	2	3
Wall thickness >45-75cm	3	3

Panel height	Fresh-concrete pressure $P_k$ 80 kN/m <sup>2</sup>			
	2.70m		3.30m	
Panel width	0.30-0.90m	1.35m	0.30-0.90m	1.35m
Wall thickness 15-45cm:	2	3	3	4
Wall thickness >45-75cm	4	4	4	4

**Panels on their sides:**

Panel width	0.30m - 0.60m	0.90m - 1.35m
	1	2

**Positions of Framax stop-end waler ties**

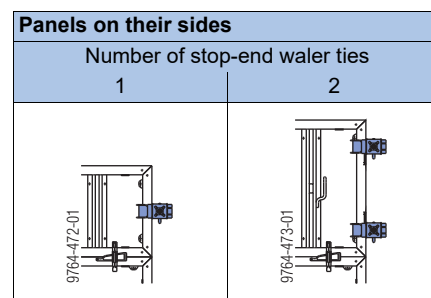
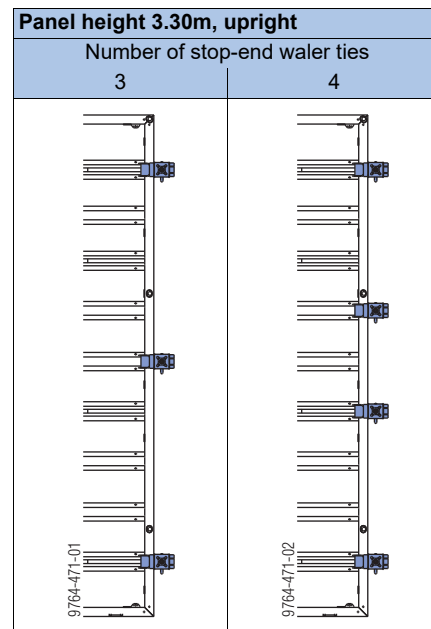
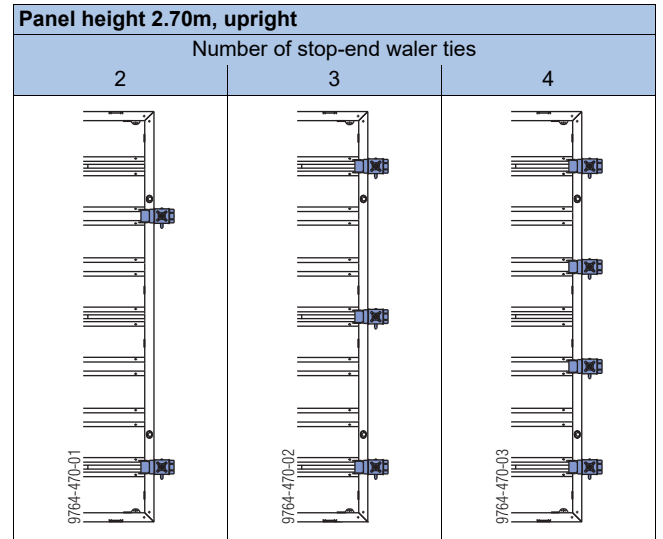

## with universal walings

Universal walings make it possible to **form stop-ends continuously across any thickness of wall.**

**Framax universal waling:**  
permitted moment: 5.2 kNm

There are **2 possible ways** of fastening the universal walings:

- with universal fixing bolts
- with stop-end ties

### Universal fixing bolts

The universal walings are mounted using universal fixing bolts and Super plates 15.0 fixed through the cross boreholes in the panels.

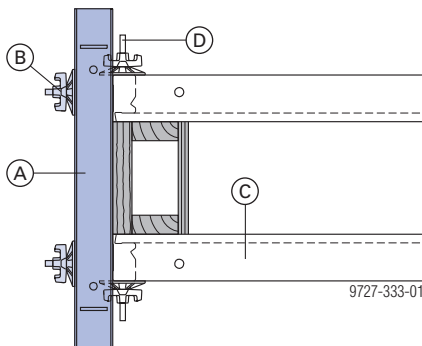
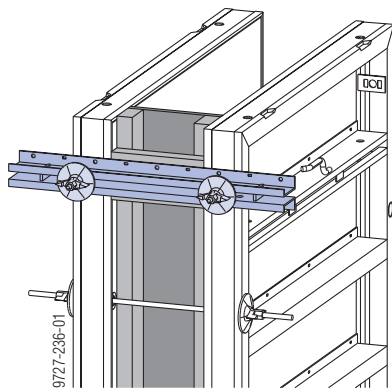

- A Framax universal waling
- B Framax universal fixing bolt + Super-plate 15.0
- C Framax Xlife panel (panel width > 0.30m)
- D Doka form-tie system

**Framax universal fixing bolt:**  
Permitted tensile force in the cross borehole of the Framax Xlife panel: 25.0 kN

## Stop-end ties

The universal walings or multi-purpose walings are fastened using Framax stop-end ties and super plates. This enables you to form **stop-ends continuously, even across large thicknesses of wall.**

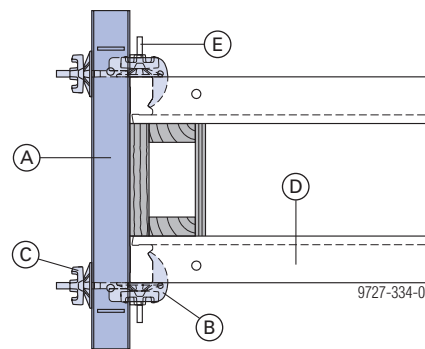
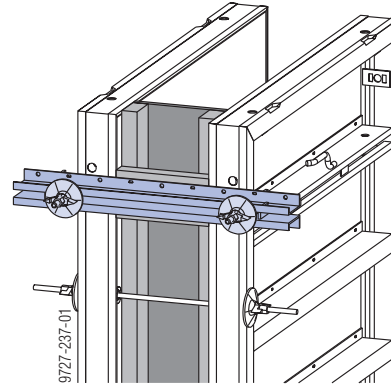

- A Framax universal waling or Multi-purpose waling WS10 Top50
- B Framax stop-end tie (clamping range: 9 - 13 cm)
- C Super plate 15.0
- D Framax Xlife panel
- E Doka tie rod system

### Position of the stop-end ties:

- To ensure uniform load transfer, the stop-end ties should be as close as possible to the centre point between two cross profiles.

**Framax stop-end tie:**  
Permissible tensile force: 15.0 kN

**Multi-purpose waling WS10 Top50:**  
Permissible moment: 12.3 kNm

Panel height: 2.70m			
Fresh-concrete pressure $P_k$ : 60 kN/m <sup>2</sup>		Fresh-concrete pressure $P_k$ : 80 kN/m <sup>2</sup>	
Wall thick-ness	Universal walings / multi-purpose wal-ings	Wall thick-ness	Universal walings / multi-purpose wal-ings
up to 40 cm	2	up to 30 cm	2
up to 50 cm	3	up to 35 cm	3
up to 60 cm	4	up to 45 cm	4
		up to 60 cm	5

Panels on their sides		
Panel width	Wall thick-ness	Universal walings / multi-purpose wal-ings
up to 0.45m	up to 60cm	1
more than 0.45m		2

## Stop-ends with joint-sealing tapes

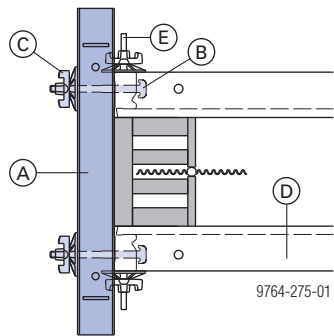

**A** Framax universal waling or Multi-purpose waling WS10 Top50

**B** Framax universal fixing bolt or Framax stop-end tie

**C** Super-plate 15.0

**D** Framax Xlife panel

**E** Doka form-tie system

# Wall junctions, offsets and steps

## Connecting to existing walls

### Right-angled connections

#### with a Framax Xlife universal panel

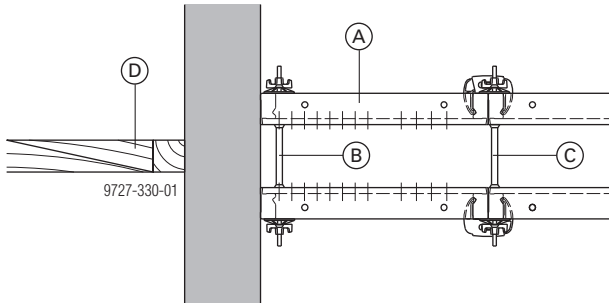

- A** Framax Xlife universal panel
- B** Doka form-tie system 15.0  
(on the Universal panel 2.70m, 3 form-ties are required, one in the first hole of each perforated profile)
- C** Doka form-tie system
- D** In-place timber brace

#### with Framax Xlife panel and pressure plate 6/15

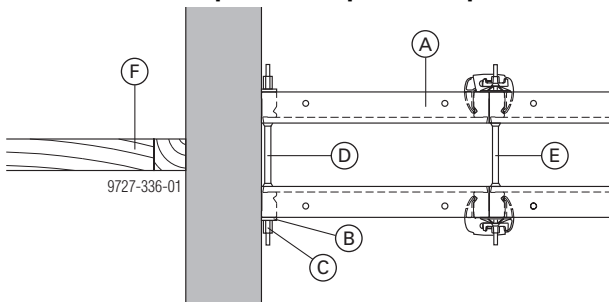

- A** Framax Xlife panel
- B** Framax pressure plate 6/15
- C** Hexagon nut 15.0
- D** Doka form-tie system 15.0mm
- E** Doka form-tie system
- F** In-place timber brace

#### with Framax Xlife panel and squared timbers

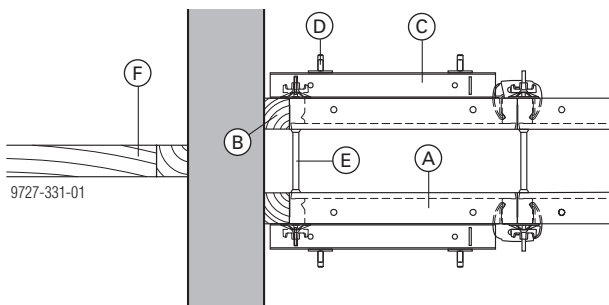

- A** Framax Xlife panel
- B** Squared timber (min. 3.5 cm up to max. 20 cm)
- C** Framax universal waling (not necessary with squared timbers up to 5 cm wide)
- D** Framax wedge clamp
- E** Doka form-tie system
- F** In-place timber brace

### In-line connections

#### with a Framax Xlife universal panel

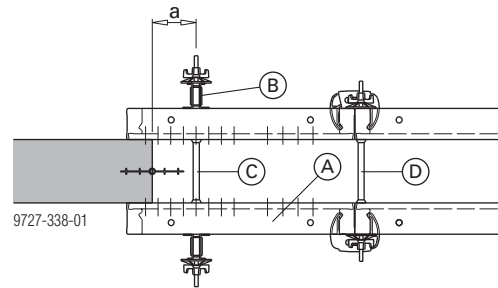

a ... max. 20.0 cm

- A** Framax Xlife universal panel
- B** Framax universal waling 1.50m
- C** Doka form-tie system 15.0 (in the Universal panel 2.70m, 3 form-ties are needed)
- D** Doka form-tie system

#### with Framax Xlife panel 2.40x2.70m

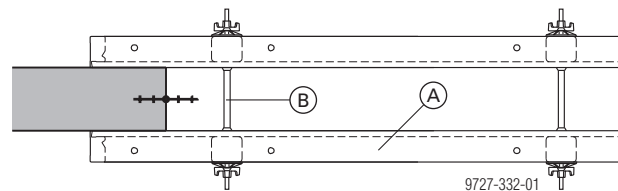

- A** Framax Xlife panel 2.40x2.70m
- B** Doka form-tie system

#### with Framax Xlife panel and squared timbers

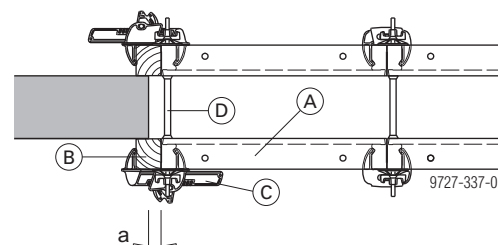

a ... max. 5 cm

- A** Framax Xlife panel
- B** Squared timber
- C** Framax multi-function clamp
- D** Doka form-tie system

## Corner connections

### without closure

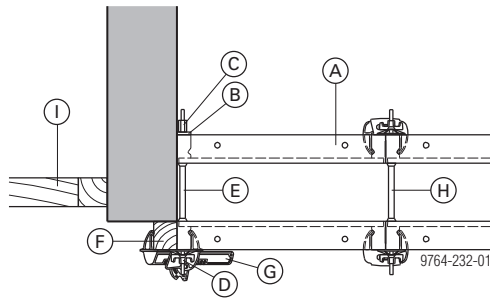

- A Framax Xlife panel
- B Framax pressure plate 6/15
- C Hexagon nut 15.0
- D Super plate 15.0
- E Doka tie rod system 15.0mm
- F Squared timber
- G Framax multi function clamp
- H Doka tie rod system
- I In-place timber brace

- F Doka tie rod system
- G Super plate 15.0
- H Tie rod 15.0

### with closure

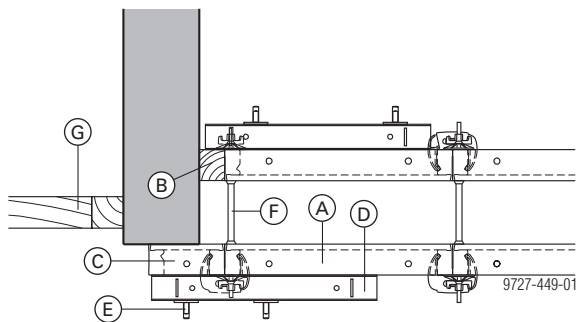

- A Framax Xlife panel
- B Squared timber (min. 3.5 cm up to max. 20 cm)
- C Framax Xlife panel 0.30m
- D Framax universal waling (not necessary with squared timbers up to 5 cm wide)
- E Framax wedge clamp
- F Doka tie rod system
- G In-place timber brace

### Short stop-end with Framax stripping corner I

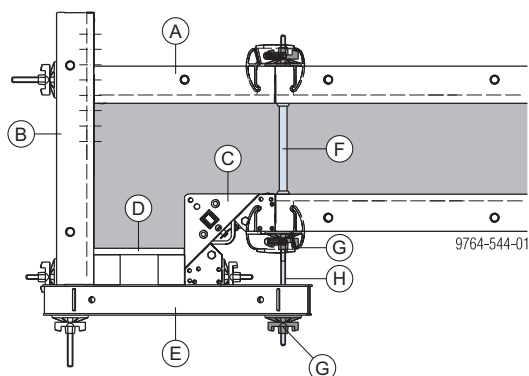

- A Framax Xlife panel 0.60m
- B Framax Xlife universal panel
- C Framax stripping corner I
- D Stop-end (site-provided)
- E Framax universal waling

## Wall offsets

### One-sided wall offset up to max. 12 cm

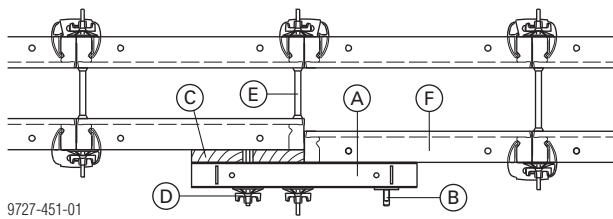

- A** Framax universal waling
- B** Framax wedge clamp
- C** Squared timber
- D** Super plate 15.0 + Framax universal fixing bolt 10-25cm
- E** Doka tie rod system
- F** Framax Xlife panel

#### Note:

- Universal waling needed in each function profile and additionally in form-tie plane (as support for form ties).
- On short walls (with high horizontal forces), shoring is required to restrain the formwork.

## Wall steps

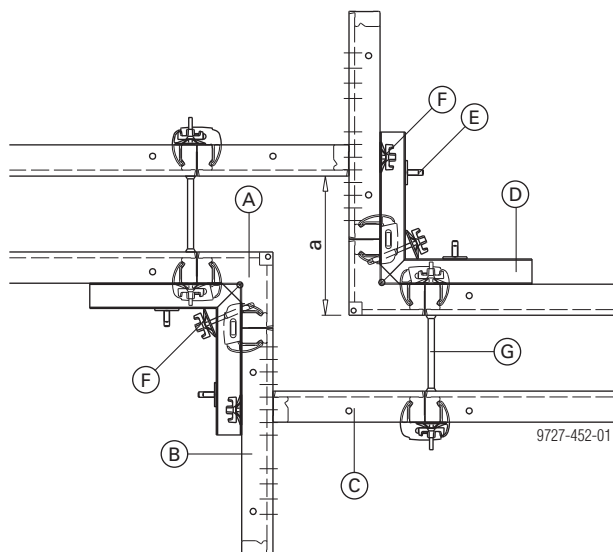

a ... 35 to 90 cm

- A** Framax Xlife inside corner
- B** Framax Xlife universal panel
- C** Framax Xlife panel 0.60m
- D** Framax universal corner waling
- E** Framax wedge clamp
- F** Super-plate 15.0 + Framax universal fixing bolt
- G** Doka form-tie system

## Window and door openings

Window and door box-outs can be formed quickly and stripped out non-destructively with **box-out clamps**. Planks are fixed in the box-out clamps by means of the integrated star grip nuts.

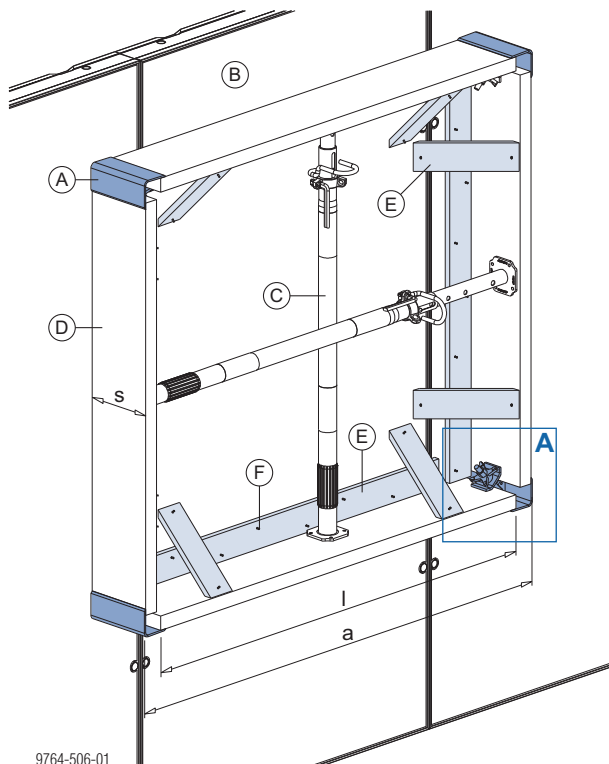

9764-506-01

### Close-up A:

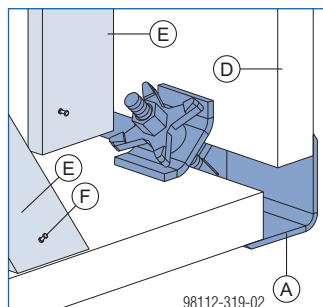

98112-319-02

a ... clear width of opening  
 l ... length of plank = a minus 12 cm  
 s ... plank width = wall thickness

- A Box-out clamp
- B Framax Xlife panel
- C Doka floor prop
- D Plank (wall thickness/2-5 cm)
- E Board (10/3 cm)
- F Double-headed nail

### How to mount:

- ▶ Place the box-out clamps on the ground, fit planks into them and tighten the star grip nuts.
- ▶ Fasten the box-outs to the wall formwork with boards 10/3 cm and nails.
- ▶ Brace vertically and horizontally with suitable floor props (as statically required).

## Plumbing accessories

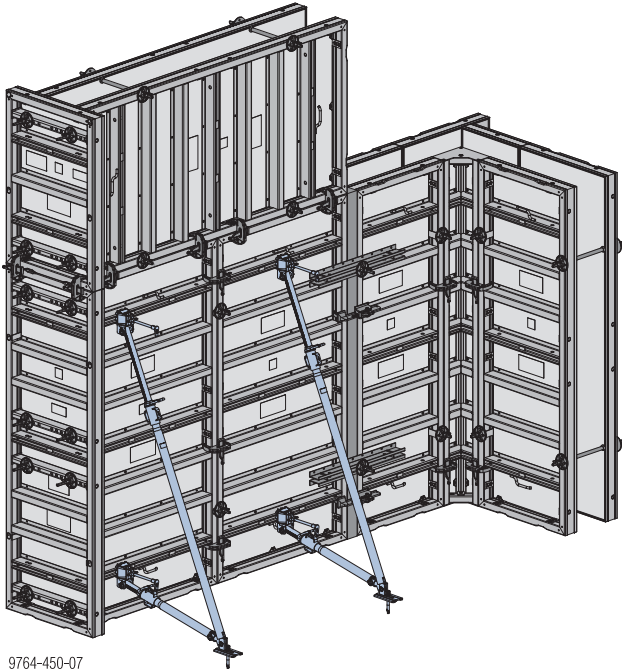

### Number of struts per 2.70 m width of gang-form:

Formwork height [m]	Panel strut		Eurex 60 550
	340	540	
4.05	1 *)		
5.40		1	
6.00	1	1	
7.20	1	2	
8.10		1	1

Max. prevailing anchoring load:  
 $F_{\text{exist}} = 13.5 \text{ kN}$  (actual load)  
 $F_d = 20.3 \text{ kN}$  (design value incl. safety factors)

\*) Up to a height of 3.30 m, the spacing of the struts can be extended to 4.05 m apart.

The values apply for a wind pressure of  $w_e = 0.65 \text{ kN/m}^2$ . This results in a peak velocity pressure of  $q_p = 0.5 \text{ kN/m}^2$  (102 km/h) where  $c_{p, \text{net}} = 1.3$ . The greater wind loads encountered at exposed formwork-ends must be restrained by additional plumbing accessories (e.g. struts or pipe-braces). In cases where higher wind pressure is encountered, the number of struts must be determined by static calculation.



For more information, see the Calculation Guide 'Wind loads to the Eurocodes', or contact Doka!

Plumbing accessories brace the formwork against wind loads and make it easier to plumb and align the formwork.



### WARNING

#### Risk of the formwork tipping over!

- ▶ Ensure stability of the formwork panels in **every** phase of the construction work!
- ▶ Observe all applicable safety regulations!
- ▶ If **high wind speeds** are likely, and when work finishes for the day or before prolonged work-breaks, always take extra precautions to fix the formwork in place.

#### Suitable precautions:

- set up the opposing formwork
- place the formwork against a wall
- anchor the formwork to the ground (e.g. using Framax floor fixing plates)
- ▶ The safety pin is only for rough adjustment of the plumbing accessory. Do not attempt to remove or release the safety pin under load.



### Universal dismantling tool

For easy operation of the spindle nuts.

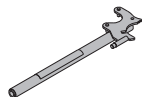

### Note:

Every gang-form must be supported by **at least 2 plumbing accessories**.

Example: Where the formwork height is 7.20 m, the following are needed for every 5.40 m wide gang-form:

- 2 Panel struts 340
- 4 Panel struts 540

## Pre-assembly

- ▶ Install heads on the plumbing accessory.
- ▶ Fix the plumbing accessory to the formwork and to the ground (see connection possibilities below for details).
- ▶ Precision adjustment of the plumbing strut with adjusting nut.



- Safety pin (A) must be pushed all the way into the plumbing accessory and secured in position by the locking spring (B).
- Ensure functionality of the locking spring (B).

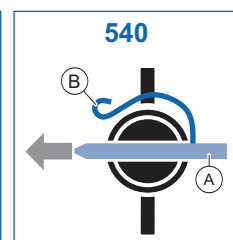
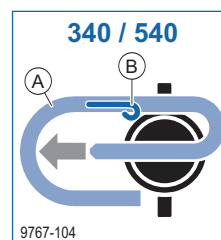

## Connection in the function profile

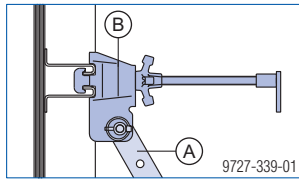

- A Panel strut 340 IB or 540 IB
- B Prop head EB

Animation: <https://player.vimeo.com/video/268536814>

## Fixing to the ground

- ▶ Anchor the plumbing accessories in such a way as to resist tensile and compressive forces!

### Drilled holes in footplate

Panel struts	Eurex 60 550

- a ... diam. 26 mm
- b ... diam. 18 mm (suitable for Doka express anchors)
- c ... diam. 28 mm
- d ... diam. 18 mm (suitable for Doka express anchors)

### Anchoring the footplate

The **Doka express anchor** can be re-used many times over.

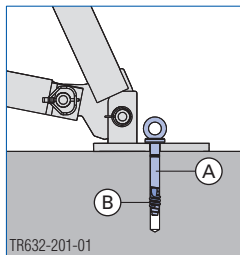

- A Doka express anchor 16x125mm
- B Doka coil 16mm

Characteristic cube compressive strength of the concrete ( $f_{ck,cube}$ ): min. 15 N/mm<sup>2</sup> (C12/15 grade concrete)

Follow the directions in the 'Doka express anchor 16x125mm' User information booklet!

### Required safe working load of alternative anchors:

$$F_d \geq 20.3 \text{ kN} \quad (F_{exist} \geq 13.5 \text{ kN})$$

Follow the manufacturers' applicable fitting instructions.

## Fixing the framed formwork panel to the ground

### with floor fixing plates

The Framax floor fixing plate is used to fix and secure framed formwork panels:

- As safeguard against lift-out by the wind.
- When panel struts are used without adjusting struts (plumbing struts).

Example: Use with plumbing strut

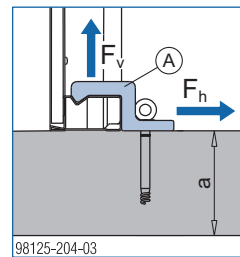

a ... min. 18 cm

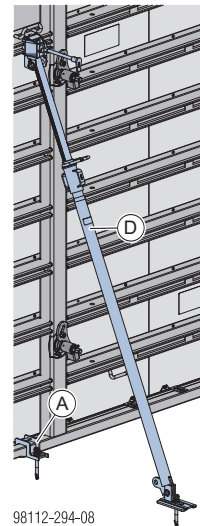

Distance from edge to panel outside edge: min. 15 cm

- A Framax floor fixing plate
- D Plumbing strut 340 IB or 540 IB

Install a Framax floor fixing plate underneath each plumbing strut.

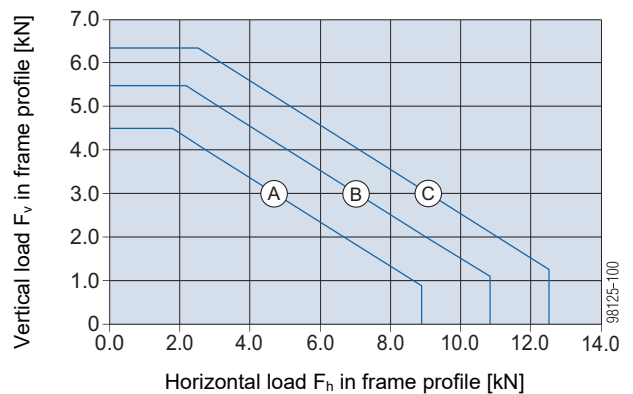

	Characteristic cube compressive strength of the concrete $f_{ck,cube}$	Max. anchoring load	
		$F_{exist}$	$F_d$
(A)	10 N/mm <sup>2</sup> (C8/10 grade concrete)	9.2 kN	13.8 kN
(B)	15 N/mm <sup>2</sup> (C12/15 grade concrete)	11.2 kN	16.8 kN
(C)	20 N/mm <sup>2</sup> (C16/20 grade concrete)	12.9 kN	19.4 kN

## Panel struts

### Product features:

- Can be telescoped in 8 cm increments
- Fine adjustment by screw-thread
- All parts are captively integrated - including the telescopic tube (has safety stop to prevent dropout)

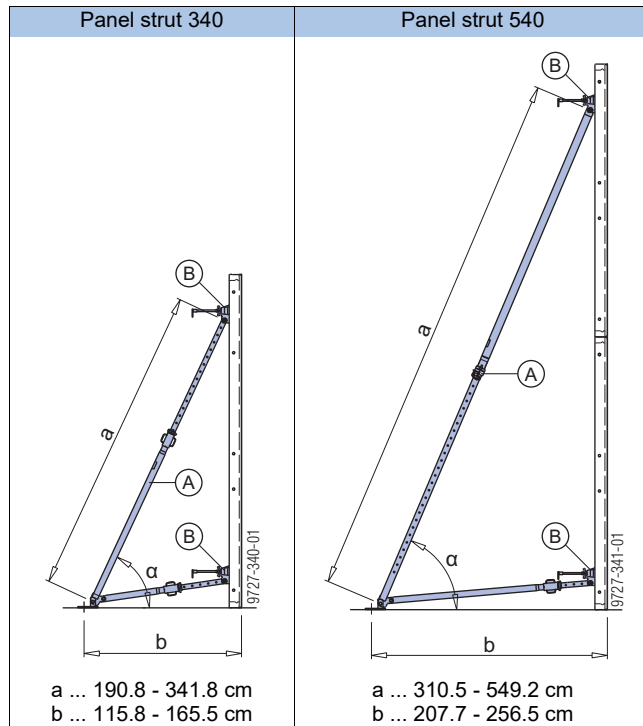

$\alpha$  ... approx. 60°

**A** Panel strut 340 IB or 540 IB

**B** Prop head EB

## Eurex 60 550 used as a shoring & plumbing accessory

As the Doka plumbing strut Eurex 60 550 - fitted with the appropriate accessories - this prop can also be used for shoring high wall formwork.

- Can be connected directly – without modification – to Doka framed formwork and Doka timber-beam formwork
- The Adjusting strut 540 Eurex 60 IB makes handling much easier, especially when the formwork is being transferred.
- Can be telescoped in 10 cm increments, with continuous fine adjustment.



Follow the directions in the 'Eurex 60 550' User Information booklet!

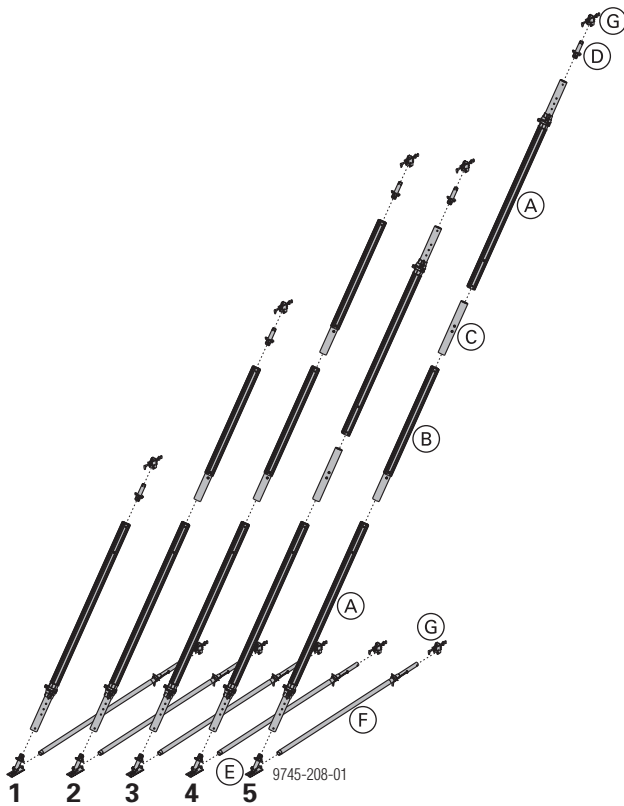

### Example of a possible combination of type 2

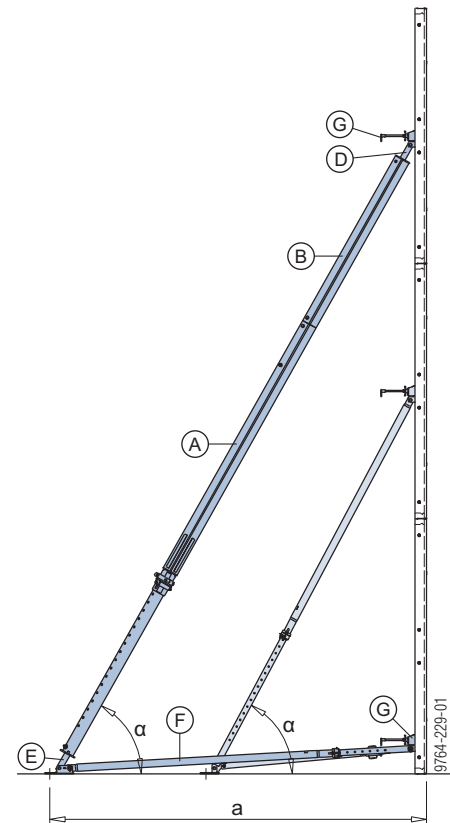

a ... 345.2 - 586.5 cm  
 $\alpha$  ... approx. 60°

- A** Plumbing strut Eurex 60 550
- B** Extension Eurex 60 2.00m
- D** Connector Eurex 60 IB
- E** Plumbing strut shoe Eurex 60 EB
- F** Adjusting strut 540 Eurex 60 IB
- G** Prop head EB

#### The rule-of-thumb here is:

The length of the plumbing accessory (i.e. the complete Plumbing strut Eurex 60 550 assembly) = the height of the gang-form to be braced.

Type	Length extended L [m]	Plumbing strut Eurex 60 550 (A)	Extension Eurex 60 2.00m (B)	Coupler Eurex 60 (C)	Connector Eurex 60 IB (D)	Plumbing strut shoe Eurex 60 EB (E)	Adjusting strut 540 Eurex 60 IB (F)	Prop head EB (G)	Weight [kg]
1	3.79 - 5.89	1	—	—	1	1	1	2	91.1
2	5.79 - 7.89	1	1	—	1	1	1	2	112.4
3	7.79 - 9.89	1	2	—	1	1	1	2	133.7
4	7.22 - 11.42	2	—	1	1	1	1	2	142.5
5	9.22 - 13.42	2	1	1	1	1	1	2	163.8

## Pouring platforms

can be quickly readied for use, and make concreting both easy and safe.

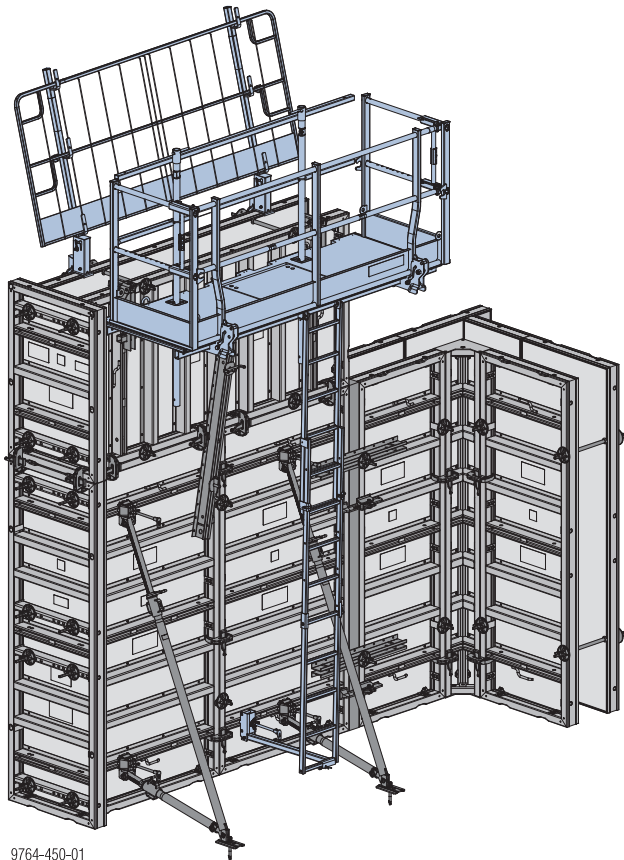

9764-450-01

### Precondition for use:

- Observe all applicable safety regulations.
- Only fit pouring platforms to formwork structures of adequate stability ensuring that the expected loads can be taken.
- Ensure that the formwork gang is sufficiently rigid.
- Brace the formwork in a windproof manner when erecting it or when it is temporarily placed in the standing position.

## Xsafe plus platform

These pre-assembled, fold-out working platforms with their integral side railings, self-closing man-hole lids and integrable ladders are ready for immediate use and greatly improve workplace safety.

### Note:

For detailed information on platform sizes, handling and accessories, see the 'Xsafe platform system plus' User Information booklet.

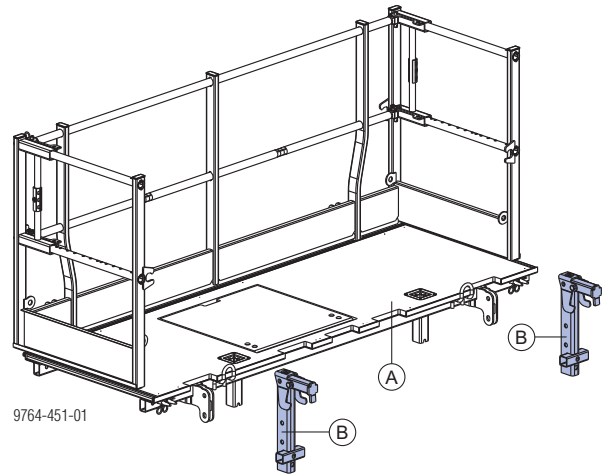

9764-451-01

**A** Xsafe plus platform

**B** Xsafe plus lifting adapter Framax (2 per platform)

**Permitted service load: 1.5 kN/m<sup>2</sup> (150 kg/m<sup>2</sup>)**

Load Class 2 to EN 12811-1:2003

**Preconditions** for using the Xsafe plus platform with the Xsafe plus lifting adapter Framax:

- max. one platform level
- max. vertical stacking configuration where the gang-form is assembled face-down on the ground and has a width of 2.70 m:  
2.70m + 1.35m or  
3.30m + 1.35m

### Installing the lifting adapter onto the platform:

- Use Connecting pins 10cm and Spring cotters 5mm to install the lifting adapters to the platform.

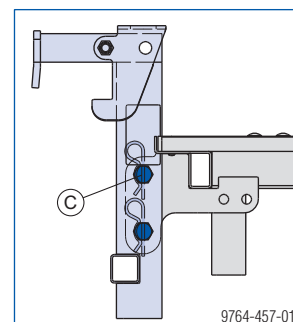

9764-457-01

**C** Connecting pin 10cm and Spring cotter 5mm of the Xsafe plus platform

**Lifting the platform onto the formwork:**

- ▶ Attach a 4-part lifting chain (e.g. Doka 4-part chain 3.20m) to the platform and hoist it towards the formwork.

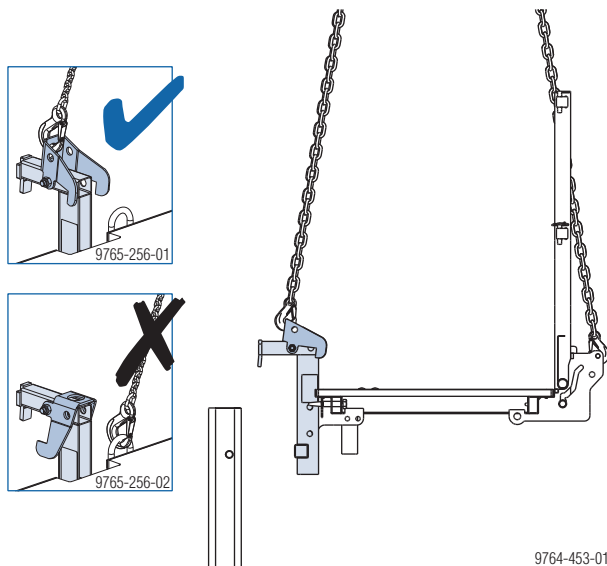

- ▶ Fix the platform to the top of the formwork.

**Note:**

On **horizontal panels**, install the platform so that it is perfectly aligned with the panel (bearing profile of the lifting adapter is resting on the cross profile of the panel).

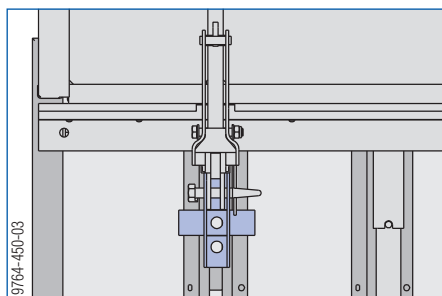

If under exceptional circumstances the platform is mounted at an offset to the outer edge of the panel, the bearing profile of the lifting adapter has to be widened.

- ▶ Push a hollow section into the bearing profile and secure it with a screw to prevent it dropping out.

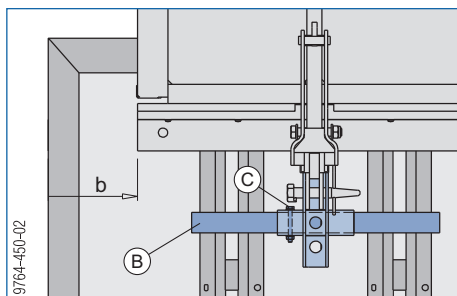

b ... offset

- B** Hollow section 40x40x2, L=550 mm, with diam. 10 mm borehole (site-provided)
- C** Hexagon bolt M8x65 + hexagon nut M8

Consequently, the bearing profile of the lifting adapter is resting on two cross profiles of the panel.

- ▶ Detach the 4-part lifting chain. The securing hooks latch into place automatically.



Do a sight-check to make sure that the securing hooks have latched into place!

The platform is now secured against accidental lift-out.

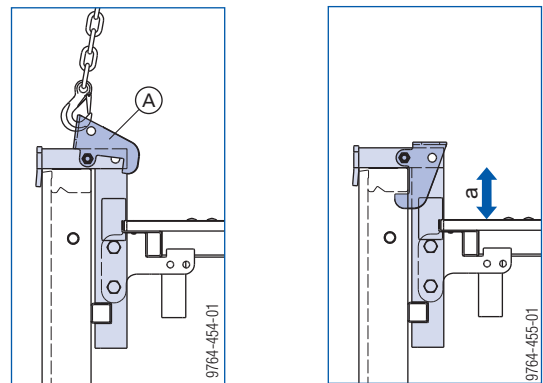

a ... 13 cm

**A** Securing hook

The level of the floor planking is 13 cm below the top edge of the formwork. This means that there is a 'boundary' on the side facing the formwork.

**Lifting the platform off the formwork:**

- ▶ Attach a 4-part lifting chain to the platform and raise it. When the platform is raised by the 4-part lifting chain on the securing hook, the platform is automatically unlocked.

**Extending the platform to either side**

The platform can be lengthened at either end by using the **Xsafe plus platform extension 0.60m**.



**CAUTION**

Platforms with platform extensions can tip up. Falling hazard!

- ▶ Do not step onto the **platform extension** until the safety hooks have been fixed in place.
- ▶ **Fix the safety hooks** of both lifting adapters with Framax universal fixing bolts and Super plates 15.0.

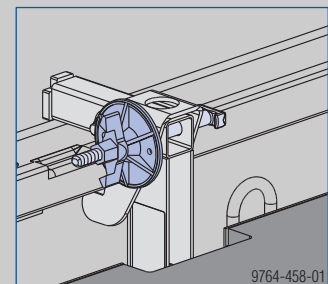

## Xsafe plus telescopic ladder

### Telescoping the ladder:

- ▶ Extend the Xsafe plus telescopic ladder or Xsafe aluminium telescopic ladder 1.55-2.70m to the required length and secure it with hinged pins (insert from outside to inside).

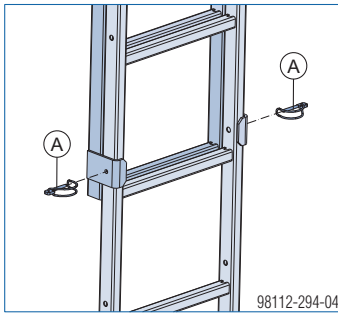

**A** Hinged pin (included in the scope of supply of the ladder)



- Check that the hinged pin is inserted the right way round!
- The clip of each hinged pin must be closed!

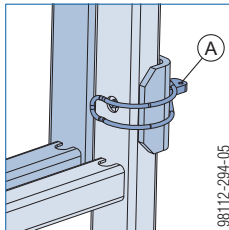

### Connection to the Xsafe plus platform:

- ▶ Hook the telescopic ladder into the integrated ladder connection.
- ▶ Secure with Spring cotters 5mm.

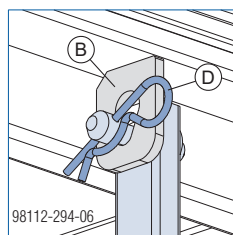
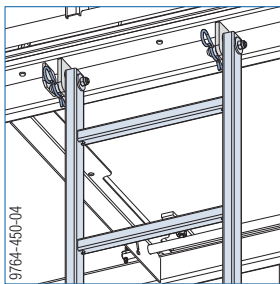

**B** Integrated ladder connection on the Xsafe plus platform

**D** Spring cotter 5mm



- The groove in the ladder pin (**C**) must be engaged in the hole of the ladder connection (**B**) !
- The ladder must be secured with Spring cotters 5mm (**D**) !

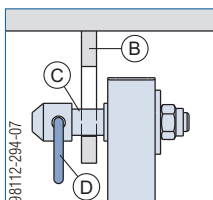

### Connection to the formwork:

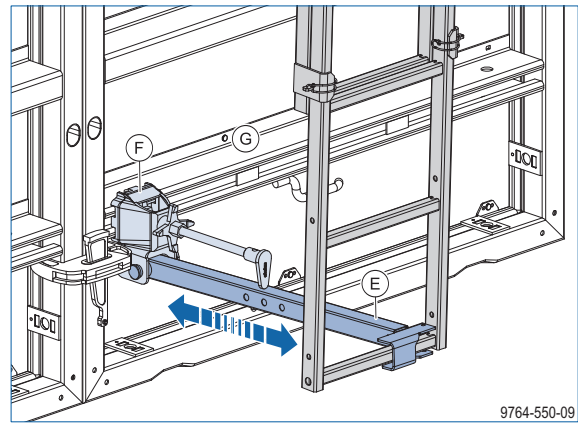

**E** Xsafe universal ladder holder

**F** Prop head EB

**G** Function profile of the Framax Xlife panel

### Moving the formwork and the platform in one piece

The **Framax lifting hook** makes it possible to reposition or raise the formwork and Xsafe plus platform upright in one piece.



#### CAUTION

Use for raising upright or laying down formwork with basic panel height 2.70m or 3.30m with a vertical stacking > 1.35m is not permitted!

- ▶ In these cases, remove the platform before raising upright / laying down the formwork.

### Repositioning:

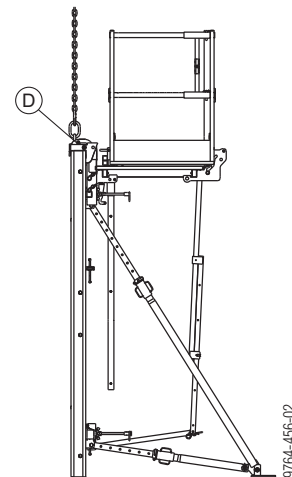

### Raising upright / laying down:

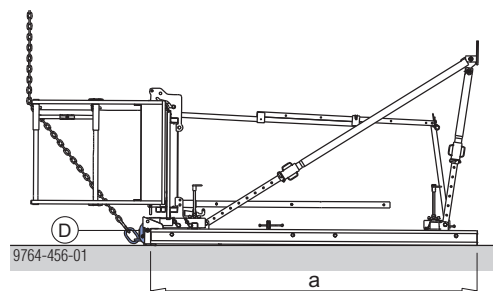

a ... Basic panel (2.70m / 3.30m) + 1.35m max.

**D** Framax lifting hook

## Framax pouring platform U

### 1.25/2.70m

A pre-assembled, foldable, ready-to-use platform, 1.25 m wide, for convenient and safe working.

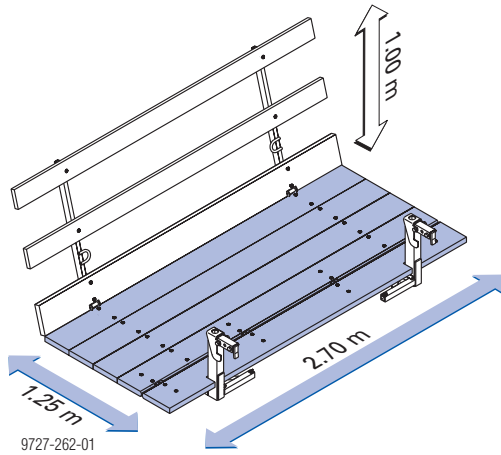

**Permitted service load: 1.5 kN/m<sup>2</sup> (150 kg/m<sup>2</sup>)**  
Load Class 2 to EN 12811-1:2003



#### NOTICE

- It is not permissible to lay the formwork down flat together with the pouring platform!
- Planks can be used to bridge decking-to-decking gaps up to 50 cm for length adaptation. Minimum plank overlap 25 cm.
- The pouring platform cannot be installed if **Framax Xlife plus panels 0.60m** are used at the top for vertical stacking.
  - Use Framax Xlife plus panels 0.60m at the bottom for vertical stacking.



Other possible areas of use for the Framax pouring platform U:

- Framed formwork Framax Xlife
  - Framed formwork Alu-Framax Xlife
  - Large-area formwork Top 50 (with Top50 adapter for Framax pouring platform U)
  - Wall formwork FF20 (with FF20 adapter for Framax pouring platform U)
- The level of the floor planking is 30 cm below the top edge of the formwork. This means that there is a 'boundary' on the side facing the formwork.
  - The guard rail can be locked in either of two positions:
    - vertical
    - tilted by 15°
  - Tilt-back board:
    - The front deck-board can be tilted back so that panel struts can be attached to the panel.
    - This lets you get at form ties at the top of the formwork, and makes room for any projecting universal walings.

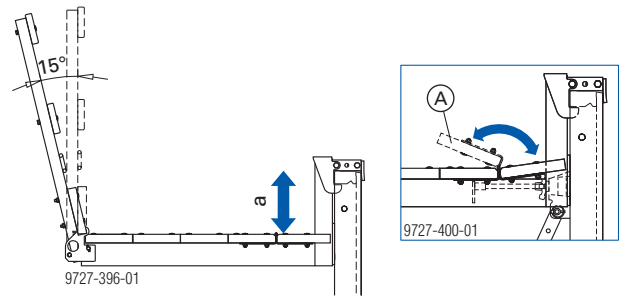

a ... 30 cm

**A** Tilt-back board

#### Preparing the pouring platform:

- ▶ Tilt up the guard rails and lock them in position.

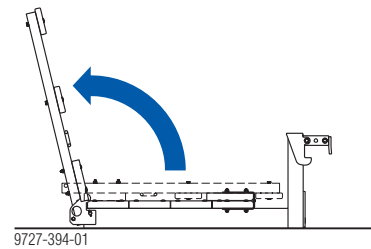

- ▶ Put both side stops into position.

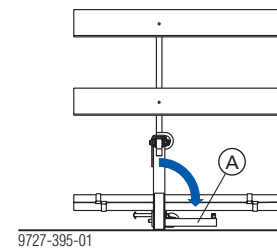

**A** Side stop

- ▶ Close the decking with the tilt-back board.

#### Lifting the platform onto the formwork:

- ▶ Attach a four-part lifting chain (e.g. Doka 4-part chain 3.20m) to the pouring platform and hoist it towards the formwork.

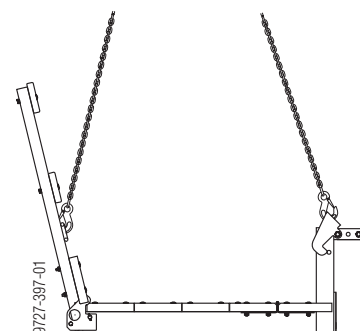

- ▶ Fix the pouring platform to the top of the formwork.

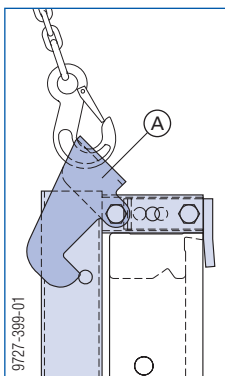

A Safety hook

- ▶ Detach the four-part lifting chain. The safety hooks latch into place automatically.



Do a sight check to make sure that the safety hooks have latched into place!

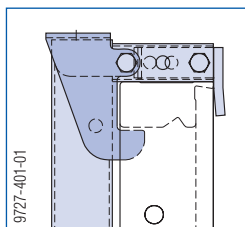

The pouring platform is now secured against accidental lift-out.

**Lifting the platform off the formwork:**

- ▶ Attach a four-part lifting chain to the pouring platform and raise it. When the pouring platform is raised by the four-part lifting chain on the safety hook, the platform is automatically unlocked.

**Transporting, stacking and storing**

Stack of 10 Framax pouring platforms U

Single collapsed platform

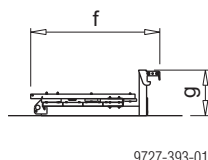
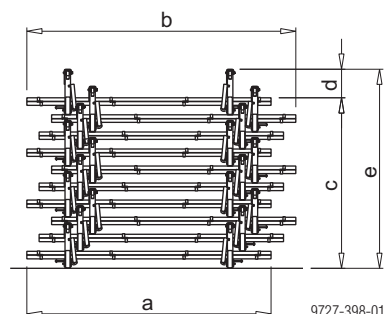

- a ... 268 cm
- b ... 295 cm
- c... 10 x 18.7 cm
- d... 31 cm
- e... approx. 218 cm
- f... 142 cm
- g... 50 cm

**Moving the formwork and the platform in one piece**

The **Framax lifting hook** allows the formwork to be repositioned together with the pouring platform.



**NOTICE**

It is not permissible to set up or lay the formwork down flat together with the pouring platform!

**Sideguards on exposed platform-ends**

On pouring platforms that do not completely encircle the structure, suitable sideguards must be placed across exposed end-of-platform zones.

**Note:**

The plank and board thicknesses stated comply with the EN 338 C24 timber. Observe all national regulations applying to deck and guardrail boards.

**Side handrail clamping unit T**

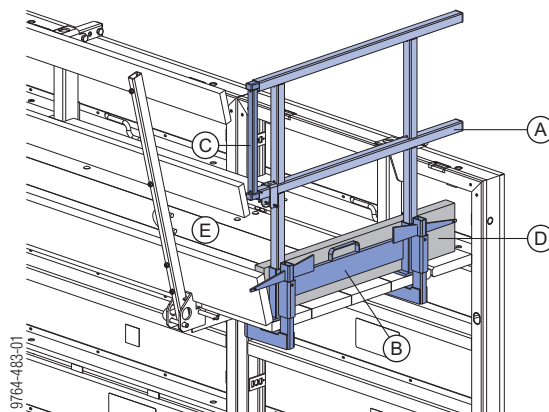

- A Side handrail clamping unit T
- B Clamping component
- C Integrated telescopic railing
- D Guardrail board min. 15x3 cm (site-provided)
- E Pouring platform

**Assembly:**

- ▶ Use the wedge (clamping range 4 to 6 cm) to fasten the clamping part to the decking of the pouring platform.
- ▶ Slot in the guardrail planks.
- ▶ Extend the telescopic railing to the desired length and secure it.
- ▶ Insert footguard (guardrail plank).

Animation: <https://player.vimeo.com/video/274887351>

## Pouring platforms with single brackets

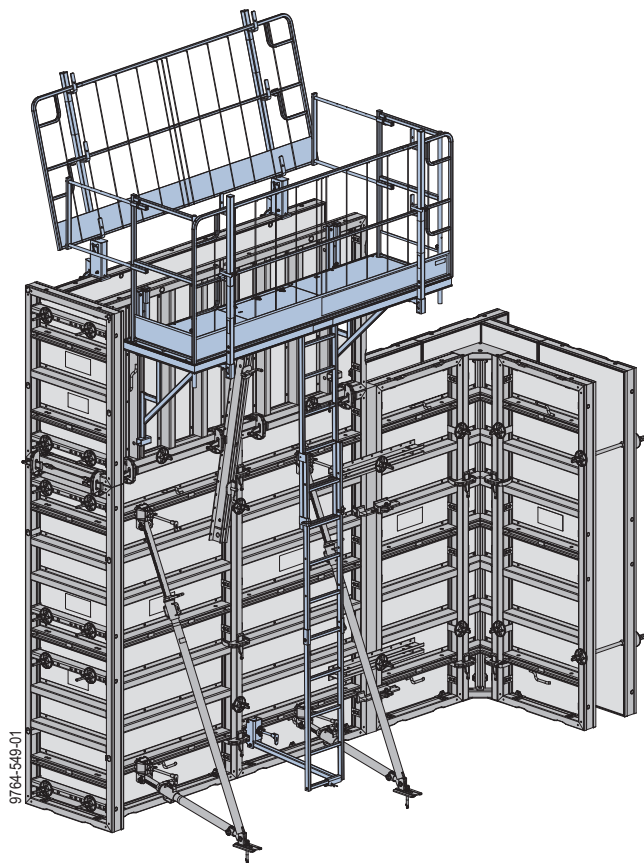

### Precondition for use:

- Observe all applicable safety regulations.
- Only fit pouring platforms to formwork structures of adequate stability ensuring that the expected loads can be taken.
- Ensure that the formwork gang is sufficiently rigid.
- Brace the formwork in a windproof manner when erecting it or when it is temporarily placed in the standing position.

### Xsafe bracket system

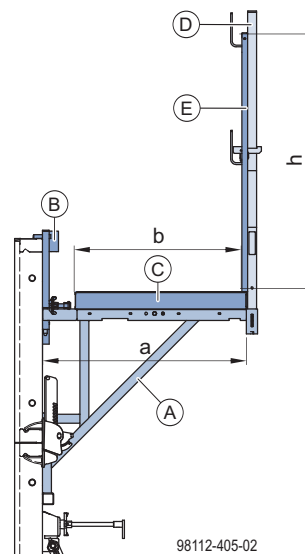

a ... 90 cm  
b ... 75 cm  
h ... 114 cm

- A** Bracket XBS 90 EP
- B** Framax adapter XBS
- C** Deck XBS
- D** Handrail post XBS 1.40m
- E** Protective grating XP 1.20m

**Permitted service load: 1.5 kN/m<sup>2</sup> (150 kg/m<sup>2</sup>)**

Load Class 2 to EN 12811-1:2003

Max. influence width: 2.00 m

## Framax adapter XBS

The Framax adapter XBS is used to install the Bracket XBS 90 EP on the Framax Xlife panel.

The movable clamping bolt allows the adapter to be adjusted flexibly to the respective position of the function profile.



### NOTICE

The bearing surface of the adapter must fit flush with the frame or cross profile.

### Possible fixing options

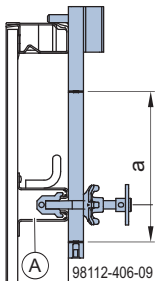

a ... adjusting range 28 cm

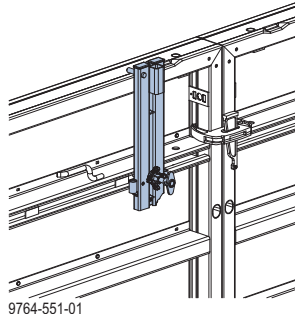

Panel upright

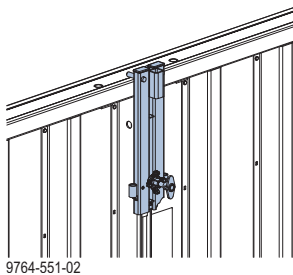

Panel on its side

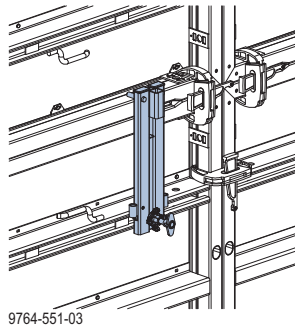

Inter-panel joint

## Deck XBS 75

### Deck XBS 75

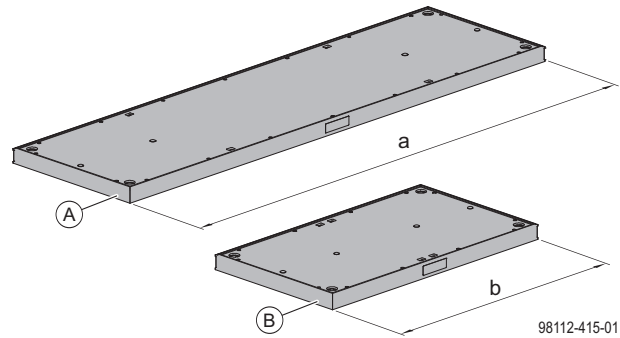

a ... 267.5 cm  
b ... 132.5 cm

**A** Deck or Hatch deck XBS 75/270cm

**B** Deck XBS 75/135cm

### Note:

The toothed strip engages in the securing hook of the bracket and serves to prevent the deck from tipping.

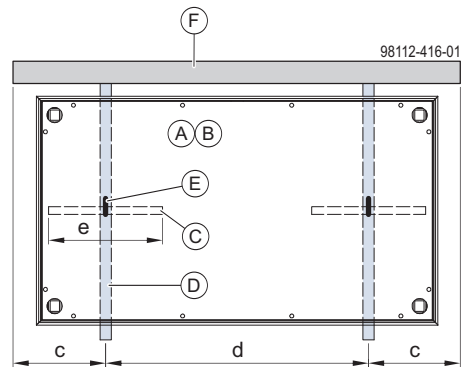

View from above

Deck XBS 75/270cm (A)	Deck XBS 75/135cm (B)
c... 11 to 50 cm	11 to 38 cm
d... 170 to 248 cm	59 to 113 cm
e... 39 cm	27 cm

**C** Toothed strip of the deck XBS

**D** Bracket XBS

**E** Securing hook of the bracket XBS

**F** Formwork panel or gang-form  
(schematic diagram)

## Erection sequence



### NOTICE

- For working at heights that cannot be reached from the floor, use a suitable elevated platform (e.g. Platform stairway 0.97m, Wheel-around scaffold DF or mobile scaffold tower)!
- Always comply with the country-specific safety regulations!
- Do not step on to the pouring platform until an all-round guardrail system (including counter railing) is in place!  
Otherwise wear a personal fall-arrest system (e.g. safety harness)!

### Note:

For details of the procedures for setting up and stripping the formwork, see the sections headed [Instructions for assembly and use for room-high formwork](#) and [Instructions for assembly and use for high formwork](#).

### Horizontal assembly

- Pre-assemble the gang-form face-down on a prepared flat area (see section [Inter-panel connections](#)).
- Attach the Tie-off set PPE type A for the personal fall-arrest system to the frame profile or function profile.

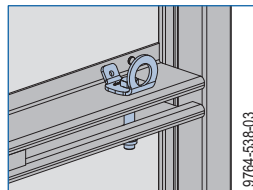
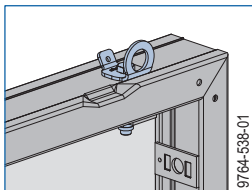

- Install the Framax adapter XBS on the gang-form while it is laid flat.

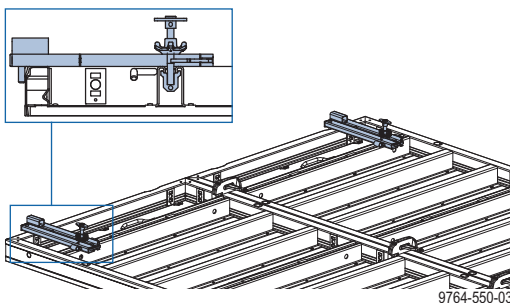

Check whether the bearing surface of the adapter is flush with the frame or cross profile.

- Hook the Bracket XBS 90 EP into the adapter. The bracket is hooked in correctly when the indicator on the adapter shows green.

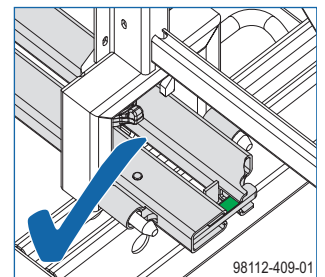
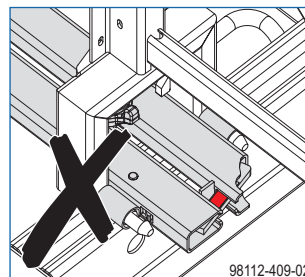
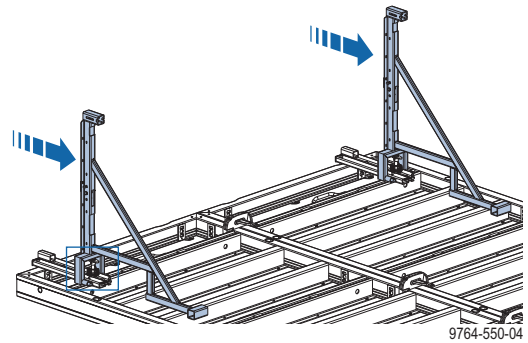

- Ensure that the securing hook (E) of the bracket is in its operational position. Otherwise remove the safety pin (F), fold up the securing hook, insert the safety pin again and secure the safety pin (F) with a linch pin.

Parking position for wooden planks

Operational position for deck XBS

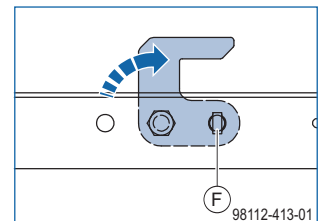
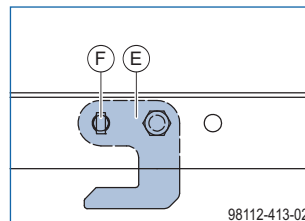

Wooden planks can also be used as platform decking instead of the deck XBS.

The wooden planks are secured from below using wood screws.

In this case the securing hook remains in parking position.

**NOTICE**

- ▶ Observe the installation direction for Hatch deck XBS 75/270cm! The hinges of the manhole lid must be on the formwork side.

- ▶ Push deck XBS onto the brackets. The securing hooks of the brackets must engage in the two toothed strips of the deck.

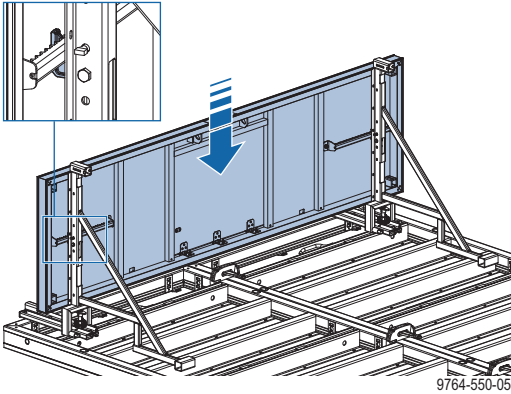

Do a sight-check to ensure that both brackets are hooked into the toothed strips to prevent slipping or tipping.

- ▶ Attach Handrail posts XBS 1.40m until the lock engages ('Easy-Click' function) and push the anti-lift-guard of the handrail posts upwards.

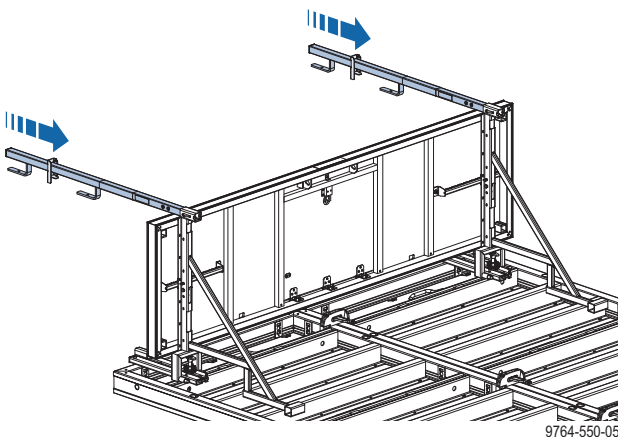

When the handrail posts have been installed, the decking is secured against being lifted out.

- ▶ Hook in protective grating XP and push the anti-lift-out guard down again. Before installing the protective grating, observe the notices in section [Lifting the formwork and Xsafe bracket system in one piece!](#)

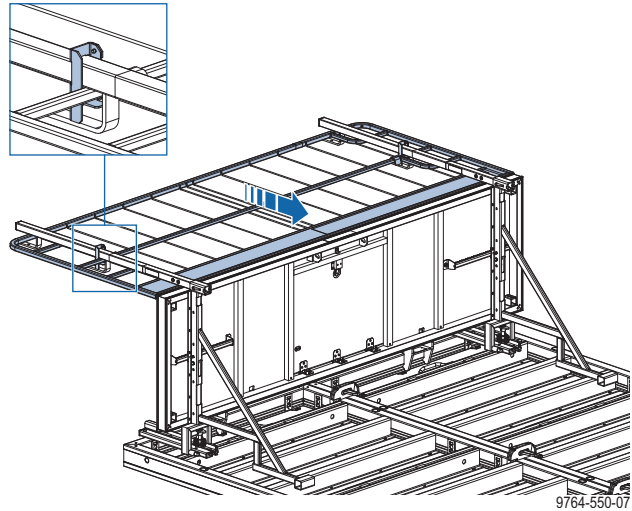

- ▶ Install panel struts (see section [Plumbing accessories](#)).
- ▶ With Hatch deck XBS 75/270cm, install Xsafe plus telescopic ladder (see section [Xsafe plus telescopic ladder](#)).
- ▶ Place suitable edge protection across exposed end-of-platform zones on pouring platforms that do not completely encircle the structure (see section [Sideguards on exposed platform-ends](#)).
- ▶ Lift the gang-form to its new location (see section [Lifting the formwork and Xsafe bracket system in one piece!](#)).
- ▶ Spray the formwork sheet with release agent (see section [Cleaning and care of your equipment](#)).
- ▶ Fix the panel struts to the ground stably.

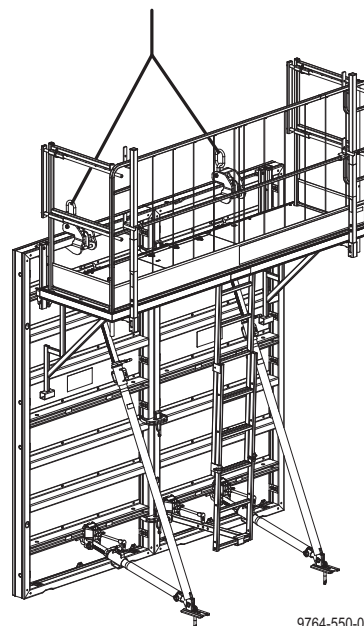

The gang-form is now stable and can be plumbed and aligned exactly, with no need for the crane.

**WARNING**

No all-round guardrail system present on the pouring platform!

Danger to life from fatal falls!

- ▶ Use a personal fall-arrest system (e.g. safety harness)  
The Tie-off set PPE type A (A) connected to the framed formwork panel serves as attachment point.

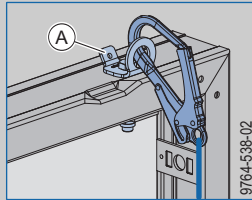

- ▶ Detach the gang-form from the crane.
- Dismantling is the reverse of the assembly procedure.

**Assembling in the upright**

- ▶ Pre-assemble the gang-form face-down on a prepared flat area (see the section headed [Inter-panel connections](#)).
- ▶ Mount panel struts to the gang-form while it is laid flat (see the section headed [Plumbing accessories](#)).

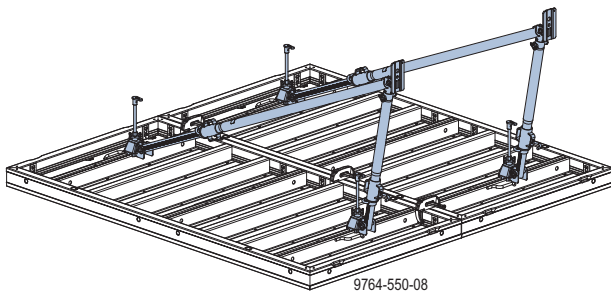

- ▶ Raise the gang-form by crane.
- ▶ Spray the formwork sheet with release agent (see the section headed [Cleaning and care of your equipment](#)).
- ▶ Lift the gang-form to its new location.
- ▶ Fix the panel struts to the ground stably.  
The gang-form is now stable and can be plumbed and aligned exactly, with no need for the crane.
- ▶ Use the Framax assembling tool to disengage the Framax lifting hooks from the gang-form (see the section headed [Lifting by crane](#)).

**Mounting the pouring platform:**

The pouring platform is installed from an elevated platform (e.g. Wheel-around scaffold DF).

**NOTICE**

- ▶ If the formwork height is 3.30m, install the brackets in the second function profile from the top to ensure reachability for installation from the elevated platform.
- ▶ Install the pouring platform from the elevated platform. (Installation steps and details, see the section headed [Horizontal assembly](#)).

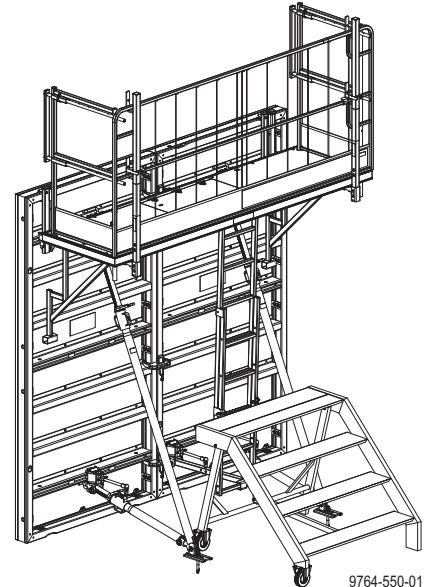

Dismantling is the reverse of the assembly procedure.

## Lifting the formwork and Xsafe bracket system in one piece

The **Framax lifting hook** allows the formwork to be raised, repositioned and laid down for cleaning together with the Xsafe bracket system (see the section headed [Lifting by crane](#)).



Before repositioning, ensure that the decking is secured with the two securing hooks and handrail posts.

### CAUTION

▶ Raising upright / laying down with installed edge protection and laying down for cleaning is only permitted up to a formwork weight of 760 kg (corresponding to basic panel height 2.70m, 3.00m or 3.30m with a vertical stacking of max. 1.35m).

### Raising upright / laying down:

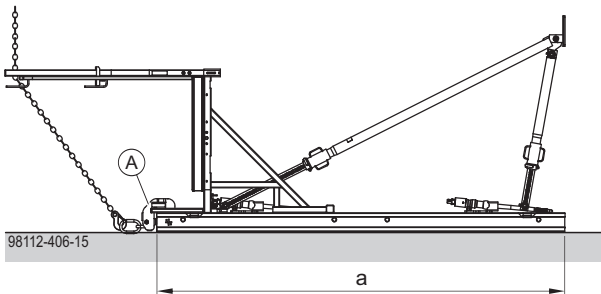

### NOTICE

With a formwork weight of > 760 kg, remove the edge protection before raising upright / laying down!

### Laying down for cleaning:

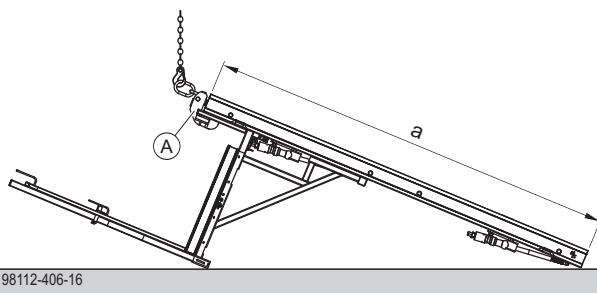

a ... basic panel (2.70m / 3.00m / 3.30m) + 1.35m max.

**A** Framax lifting hook

### NOTICE

- Laying down for cleaning is permitted only with max. one deck level!
- Before laying down for cleaning, remove the panel struts (and fold down or remove the telescopic ladder, if applicable)!

## Gap Filler Plank

The infill deck XBS allows deck openings in the Xsafe bracket system from 0.30 to 1.35 m to be bridged.

The infill deck XBS can be used in the straight wall or in inside corners (see the section headed [Inside corners](#)).

### Note:

The infill deck is secured on one side and rests free on the other side.

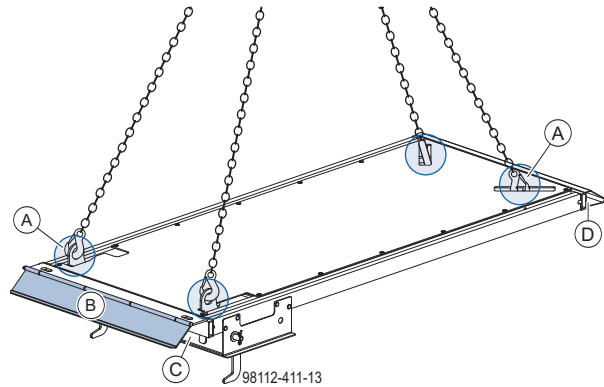

- A** Crane lifting point
- B** Deck hatch
- C** Secured side
- D** Resting side

### Secured side with securing housing in detail

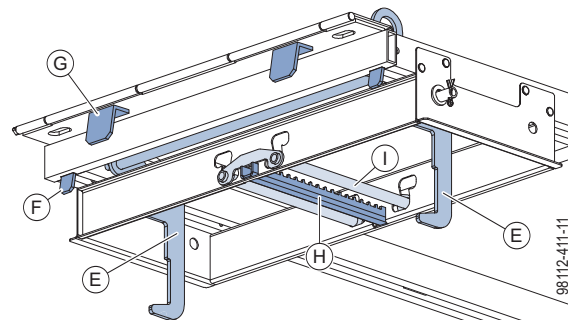

View from below

- E** Securing element
- F** Suspension plate for hooking into deck XBS
- G** Suspension plate for hooking into infill deck XBS
- H** Toothed strip for securing the position
- I** Anti-slip guard



**NOTICE**

- The infill deck must have at least 25 cm contact on the resting side.
- Sufficient contact is assured if the crane attachment openings (J) are completely covered by the deck below.

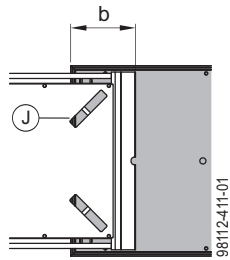

b ... min. 25 cm

**Closure in the straight wall**

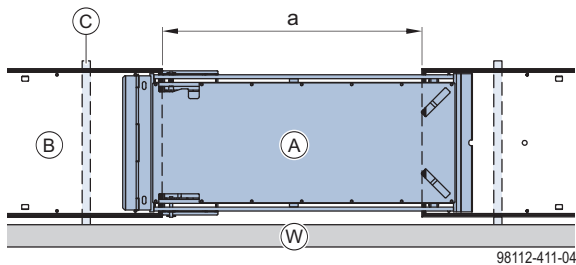

a ... 0.30m - 1.35m

- A** Infill deck XBS
- B** Deck XBS
- C** Bracket XBS
- W** Gang-form (schematic diagram)

**Installation:**

First install the standard XBS decks and secure with handrail post, only then install the infill deck.

- Push the securing element towards the frame (1) and swing up (2).

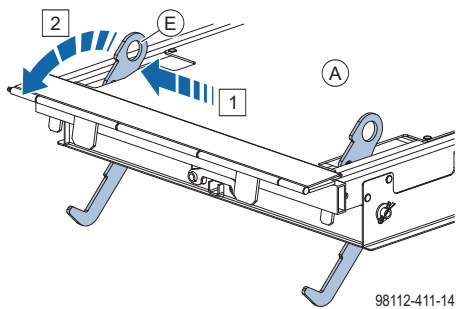

- A** Infill deck XBS
- E** Securing element

- Lift the infill deck to its intended location.

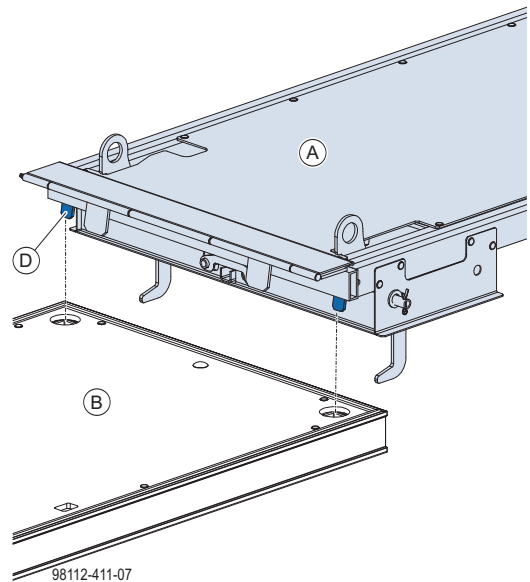

- A** Infill deck XBS
- B** Deck XBS
- D** Suspension plate for hooking into deck XBS

Suspension plates engage in the recesses in the deck XBS.

- Swing the securing element on the crane lifting point down.

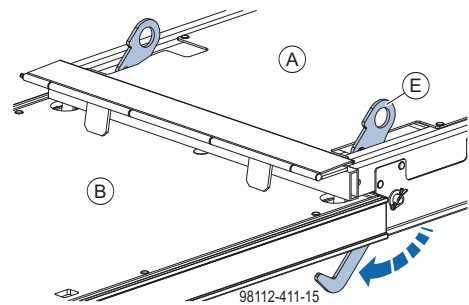

- Close the deck hatch.

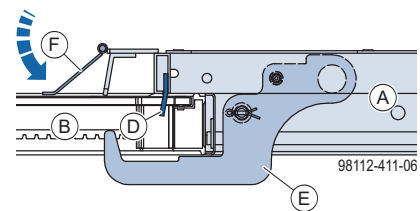

- A** Infill deck XBS
- B** Deck XBS
- D** Suspension plate for hooking into deck XBS
- E** Securing element
- F** Deck hatch



Do a sight-check to ensure that the securing element is closed.

- Install Protective grating XP 1.20m.

## Inside corners

### Note:

- The brackets XBS and decks XBS can be installed on the gang-form while it is laid flat!
- Installation of infill deck XBS is only possible on the upright gang-form after installation of the brackets XBS and decks XBS!
- See the section headed [Erection sequence!](#)

### Inside corner with standard XBS decks

#### 2 decks XBS

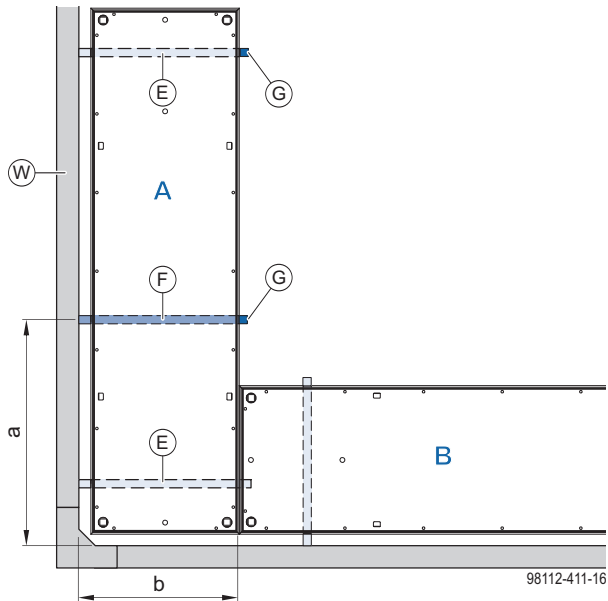

a ... from inside corner to additional bracket XBS: 0.93 m - 1.53 m  
b ... 0.92 m

- A Deck A - Deck XBS**
- B Deck B - Deck XBS**
- E Bracket XBS**
- F Bracket XBS (additionally required)**
- G Handrail post XBS 1.40m**
- W Gang-form (schematic diagram)**



### NOTICE

When installing **deck A**, note:

- Install the first bracket XBS as far in the corner as possible (immediately next to the inter-panel connections of the inside corner)!
- An additional bracket XBS with handrail post XBS is required for installation of the edge protection!

### Inside corner with closure on one side

#### 1 deck XBS / 1 infill deck XBS

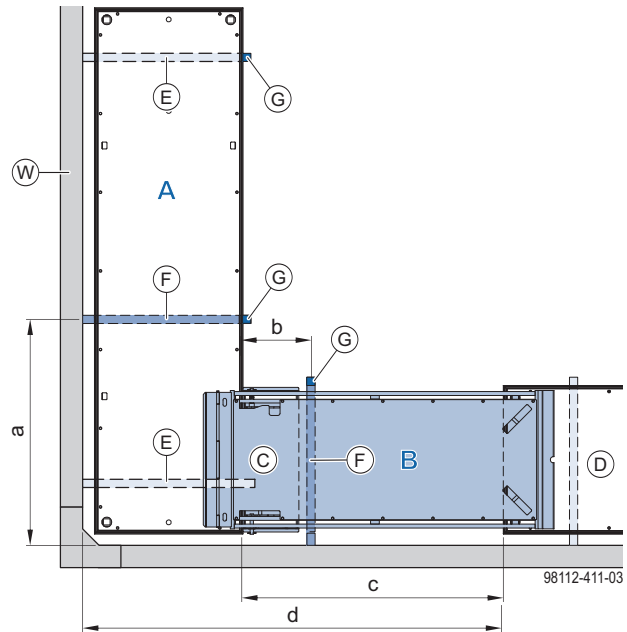

a ... from inside corner to additional bracket XBS: 0.93 m - 1.53 m  
b ... from deck A to additional bracket XBS: 0.35 m - 0.60 m  
c ... 0.30 m - 1.35 m  
d ... 1.20 m - 2.25 m

- A Deck A - Deck XBS**
- B Deck B - Infill deck XBS**
- C Securing housing of infill deck XBS**
- D Deck XBS (standard deck)**
- E Bracket XBS**
- F Bracket XBS (additionally required)**
- G Handrail post XBS 1.40m**
- W Gang-form (schematic diagram)**

### Installation sequence:

1. **Standard XBS deck (D)**
2. **Deck A (A)**  
(see section [Inside corner with standard XBS decks](#))
3. **Deck B (B)**

### Installation of deck B:



### NOTICE

- An additional bracket XBS with handrail post XBS is required for installation of the edge protection!  
**Exception:** The first bracket of the next standard deck is less than 0.60 m from the corner.
- Do not install the additional bracket directly under the securing housing of the infill deck!

- Swing up the securing element of the infill deck XBS (see section [Gap Filler Plank](#)).

- ▶ Lift the infill deck XBS to its intended location.

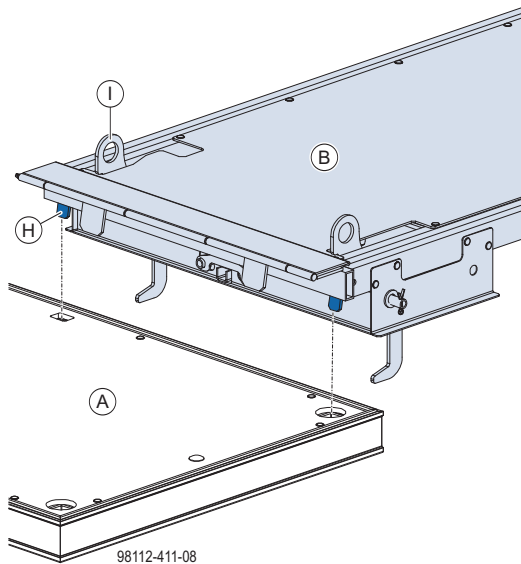

Suspension plates engage in the recesses in deck A - deck XBS.

- ▶ Close securing element and deck hatch (see section [Gap Filler Plank](#)).

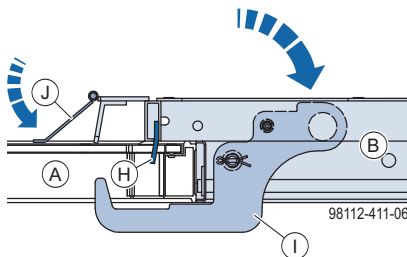

- A** Deck A - Deck XBS
- B** Deck B - Infill deck XBS
- H** Suspension plate for hooking into deck XBS
- I** Securing element
- J** Deck hatch



Do a sight-check to ensure that the securing element is closed.

- ▶ Install Handrail post XBS 1.40m and Protective grating XP 1.20m.

### Inside corner with closure on both sides

#### 2 infill decks XBS

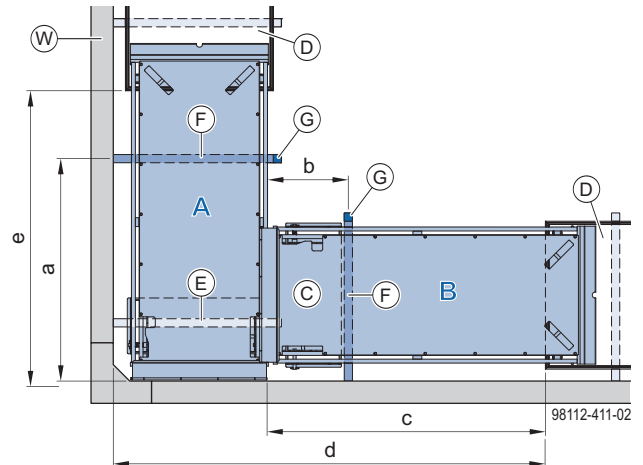

- a ... from inside corner to additional bracket XBS: 0.93 m - 1.53 m
- b ... from deck A to additional bracket XBS: 0.45 m - 0.60 m
- c ... 0.39 m - 1.44 m
- d ... 1.25 m - 2.30 m
- e ... 0.48 m - 1.53 m

- A** Deck A - Infill deck XBS
- B** Deck B - Infill deck XBS
- C** Securing housing of infill deck XBS
- D** Deck XBS (standard deck)
- E** Bracket XBS
- F** Bracket XBS (additionally required)
- G** Handrail post XBS 1.40m
- W** Gang-form (schematic diagram)

#### Installation sequence:

1. Standard XBS deck (D)
2. Deck A (A)
3. Deck B (B)

#### Installation of deck A:



#### NOTICE

- ▶ Install the first bracket XBS as far in the corner as possible (immediately next to the inter-panel connections of the inside corner)!
- ▶ An additional bracket XBS with handrail post XBS is required for installation of the edge protection!  
**Exception:** The first bracket of the next standard deck is less than 1.53 m from the corner.

- ▶ Lift the infill deck XBS to its intended location. The distance from the narrow side of the infill deck to the formwork should be as small as possible.
- ▶ Lift the anti-slip guard on the formwork side so that the securing hook of the bracket can engage in the toothed strip of the infill deck.

- ▶ Actuate the anti-slip guard briefly so that the anti-slip guard closes.

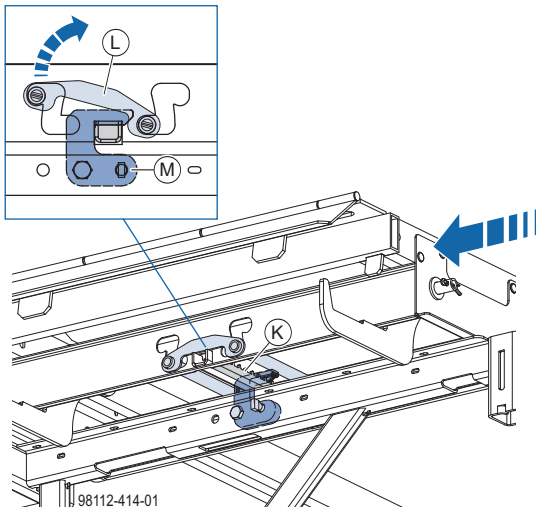

- K** Toothed strip for securing the position
- L** Anti-slip guard
- M** Securing hook

With the anti-slip guard closed, the deck is secured against slipping on the bracket.

 Do a sight-check to ensure that the anti-slip guard is closed.

**Installation of deck B:**

**NOTICE**

- ▶ An additional bracket XBS with handrail post XBS is required for installation of the edge protection!
  - Exception:** The first bracket of the next standard deck is less than 0.60 m from the corner.
- ▶ Do not install the additional bracket directly under the securing housing of the infill deck!
- ▶ Swing up the securing element of the infill deck (see section [Gap Filler Plank](#)).

- ▶ Lift the infill deck XBS to its intended location.

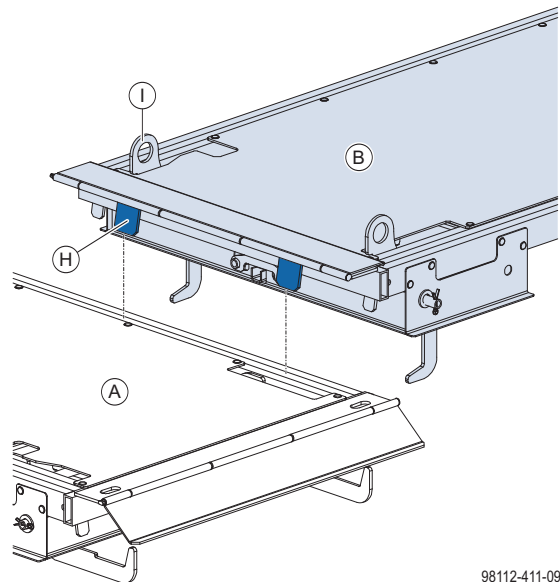

Suspension plates engage in the recess in deck A - infill deck XBS.

- ▶ Close the securing element (see [Gap Filler Plank](#)).

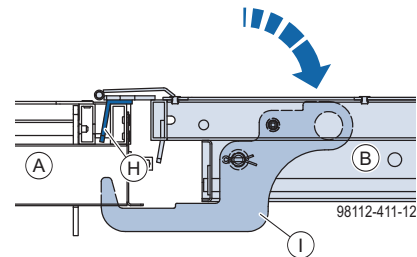

- A** Deck A - Infill deck XBS
- B** Deck B - Infill deck XBS
- H** Suspension plate for hooking into infill deck XBS
- I** Securing element

 Do a sight-check to ensure that the securing element is closed.

- ▶ Install Handrail post XBS 1.40m and Protective grating XP 1.20m.

## Sideguards on exposed platform-ends

On pouring platforms that do not completely encircle the structure, suitable sideguards must be placed across exposed end-of-platform zones.

### Installation:

- ▶ Insert Side railing XBS 75cm into deck XBS.

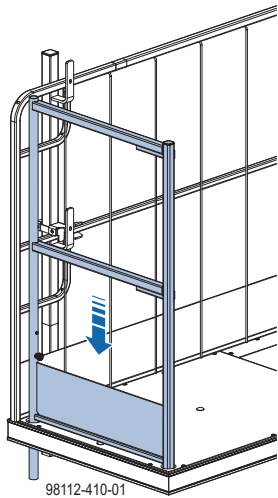

Safety latch (B) on post (C) must engage on the underside of deck XBS (A).

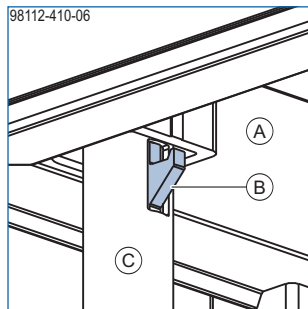

### To open the side railing:

- ▶ Press the locking button and lift Side railing XBS 75cm by approx. 10 cm.

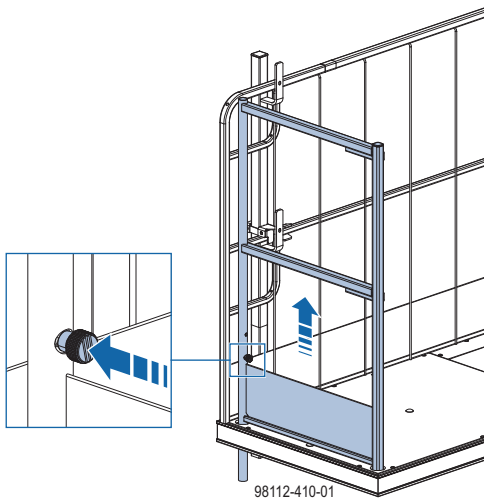

- ▶ Swing Side railing XBS 75cm 90° inwards and hook into Handrail post XBS 1.40m.

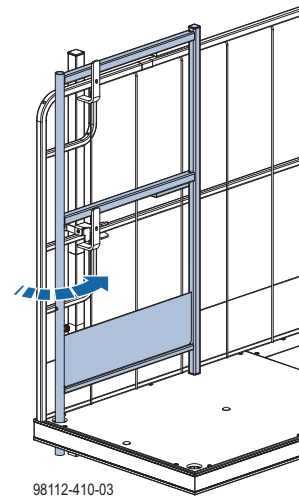

The end-of-platform sideguard can be extended with the Handrail extension XBS (D).

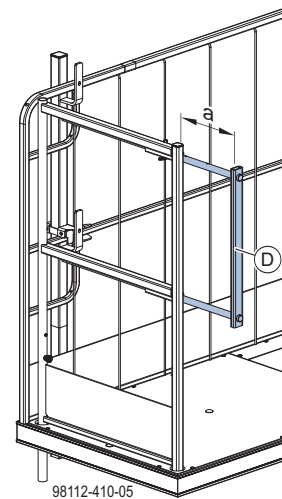

e ... can be telescoped between 15 cm and 60 cm in increments of 5 cm

## Framax bracket 90

### Note:

The plank and board thicknesses stated comply with the EN 338 C24 timber.

Observe all national regulations applying to deck and guardrail boards.

Framax brackets 90 are easy to assemble by hand and provide a 90 cm wide pouring platform.

### Handrail post variants:

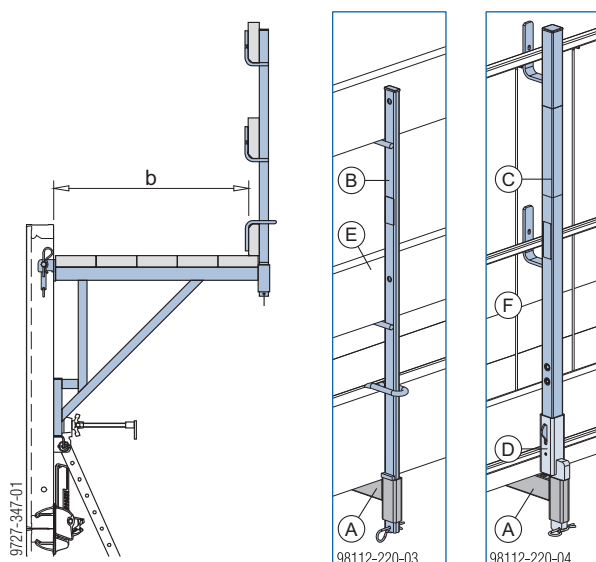

b ... 90 cm

- A Framax bracket 90 EP
- B Handrail post 1.00m
- C Handrail post XP 1.20m
- D Bracket adapter XP FRR 50/30cm
- E Guardrail board (or scaffold tube)
- F Protective grating XP 1.20m (or guardrail boards)

**Permitted service load: 1.5 kN/m<sup>2</sup> (150 kg/m<sup>2</sup>)**

Load Class 2 to EN 12811-1:2003

Max. influence width: 2.00 m



### NOTICE

The brackets must be secured against accidental lift-out.

**Deck-boards and guardrail boards:** Per 1 metre length of platform, 0.9 m<sup>2</sup> of deck-boards and 0.6 m<sup>2</sup> of guardrail boards are needed (provided on site).

Board thicknesses for centre-to-centre spans up to 2.50 m:

- Deck-boards min. 20/5 cm
- Guardrail boards min. 15/3 cm

**Bolting items required for securing the deck-boards (fasteners per bracket):**

- 5 cup square bolts M10x120
- 5 spring washers A10
- 5 hexagon nuts M10

**Fixing the guardrail boards:** use nails

### Using scaffold tubes

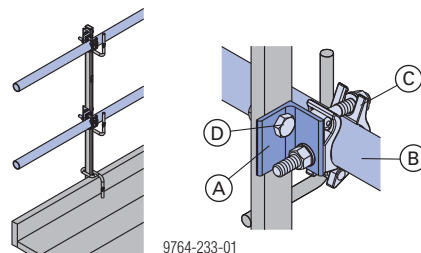

9764-233-01

Tools required: Open-end spanner 22 for mounting the couplers and scaffold tubes.

- A Scaffold tube connection
- B Scaffold tube 48.3mm
- C Screw-on coupler 48mm 50
- D Hexagon bolt M14x40 + hexagon nut M14  
(Bolting items required)

### Possible ways of fixing to upright panels

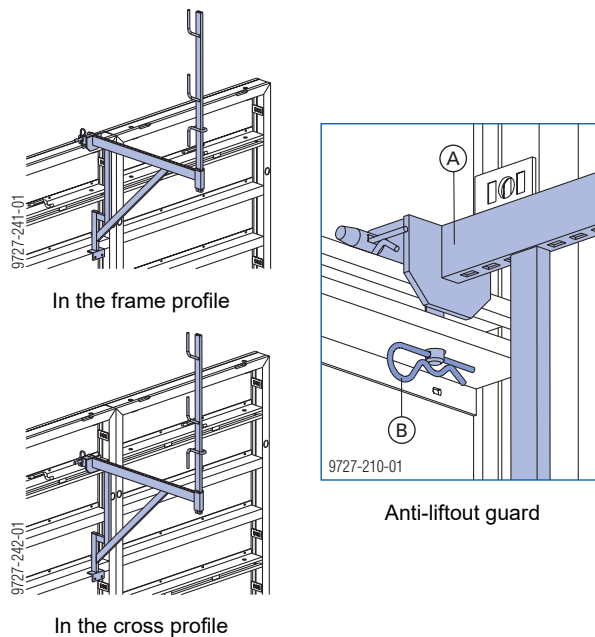

- A Framax bracket 90 EP
- B Spring cotter

### Note:

Where brackets need to be fixed to the middle cross profile of upright Framax Xlife universal panels 2.70m and 3.30m (2008 models onward), this can also be done in the left-hand borehole.

### Possible ways of fixing to horizontally placed panels

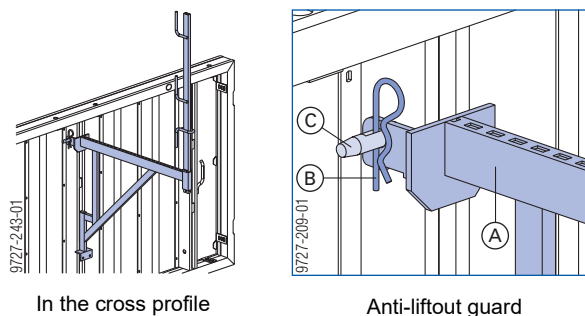

- A Framax bracket 90 EP
- B Spring cotter
- C Wedge bolt RA 7.5

## Erection sequence



### NOTICE

- For working at heights that cannot be reached from the floor, use a suitable elevated platform (e.g. Platform stairway 0.97m, Wheel-around scaffold DF or mobile scaffold tower)!
- Always comply with the country-specific safety regulations!
- Do not step on to the pouring platform until an all-round guardrail system (including counter railing) is in place!  
Otherwise wear a personal fall-arrest system (e.g. safety harness)!

### Note:

- For details of the procedures for setting up and stripping the formwork, see the section headed [Instructions for assembly and use for room-high formwork](#).
- For the assembly procedure for high formwork, see the section headed [Instructions for assembly and use for high formwork](#).

### Horizontal assembly

- Pre-assemble the gang-form face-down on a prepared flat area.
- Install the attachment point for the personal fall-arrest system (Tie-off set PPE type A).

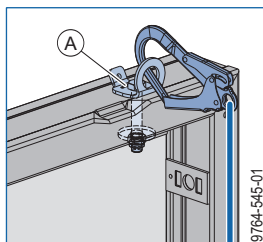

- Install brackets, decking and if applicable, end-of-platform sideguards and Ladder system XS on the gang-form while it is laid flat.

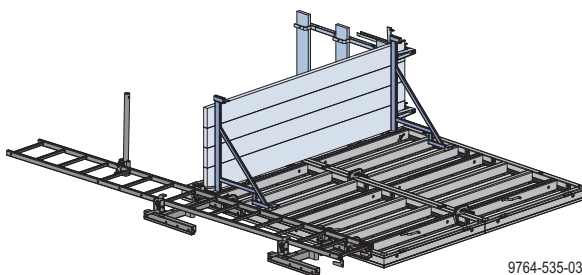

### NOTICE

- Do not set down the gang-form on the pouring platform.
- Use the crane to turn the gang-form over so that the pouring platform is accessible from floor level.

- Install the handrail posts and safety barrier.

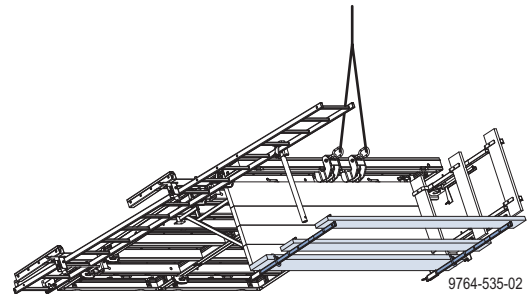

- Spray the formwork sheet with release agent.
- Lift the gang-form to its new location.
- Install the panel struts and secure them firmly to the floor. The top strut heads are reached by standing on an elevated platform (e.g. Platform stairway 0.97m).

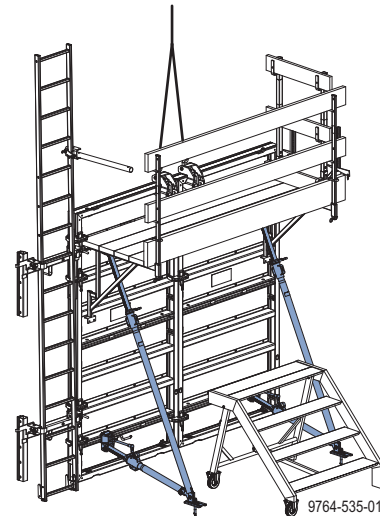

The gang-form is now stable and can be plumbed and aligned exactly, with no need for the crane.



### WARNING

No all-round guardrail system present on the pouring platform!

Danger to life from fatal falls!

- Use a personal fall-arrest system (e.g. safety harness)

The Tie-off set PPE type A connected to the framed formwork panel serves as attachment point.

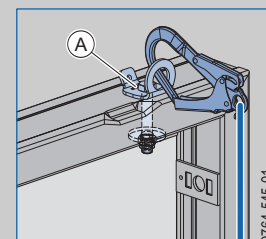

- Detach the gang-form from the crane.
- Dismantling is the reverse of the assembly procedure.

## Assembling in the upright

- ▶ Pre-assemble the gang-form face-down on a prepared flat area.
- ▶ Install panel struts and, if applicable, Ladder system XS on the gang-form while it is laid flat.

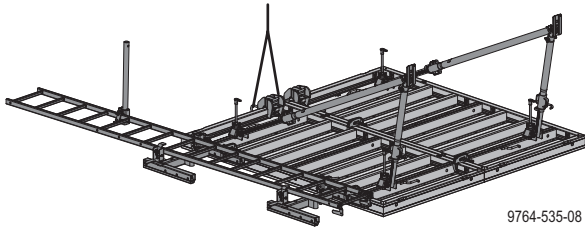

- ▶ Raise the gang-form by crane.
- ▶ Spray the formwork sheet with release agent.
- ▶ Lift the gang-form to its new location.
- ▶ Fix the panel struts to the ground stably.  
The gang-form is now stable and can be plumbed and aligned exactly, with no need for the crane.
- ▶ Use the Framax assembling tool to disengage the gang-form from the crane (see the section headed [Assembling tool](#)).

### Mounting the pouring platform:

The pouring platform is installed from an elevated platform (e.g. Wheel-around scaffold DF).



#### NOTICE

- ▶ If the formwork height is 3.30m, install the brackets in the second function profile from the top to ensure reachability for installation from the elevated platform.
- ▶ Install the brackets and handrail posts.
- ▶ Install the guardrail boards (starting at the top) or protective gratings, as applicable.

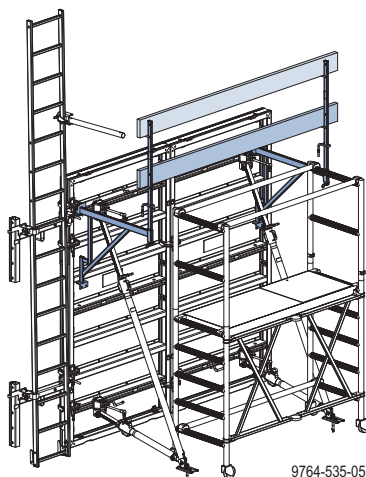

The Alu beam fork H20 (A) is a helpful tool for inserting the guardrail boards.

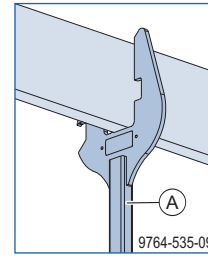

- ▶ Install the deck-boards (starting at the formwork side).

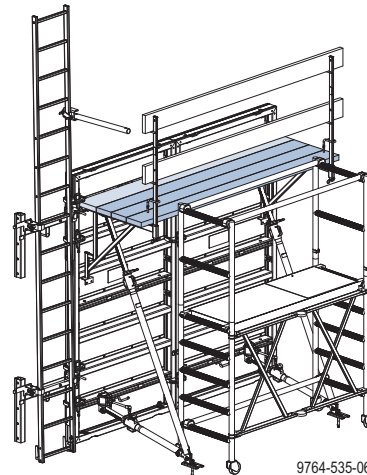

- ▶ Install the toeboards and, if applicable, the end-of-platform sideguards.

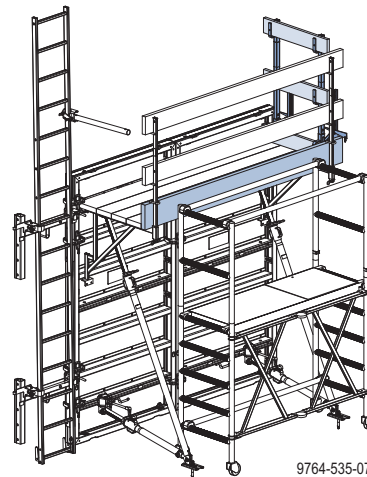

Dismantling is the reverse of the assembly procedure.

## Sideguards on exposed platform-ends

On pouring platforms that do not completely encircle the structure, suitable sideguards must be placed across exposed end-of-platform zones.

### Xsafe edge protection XP

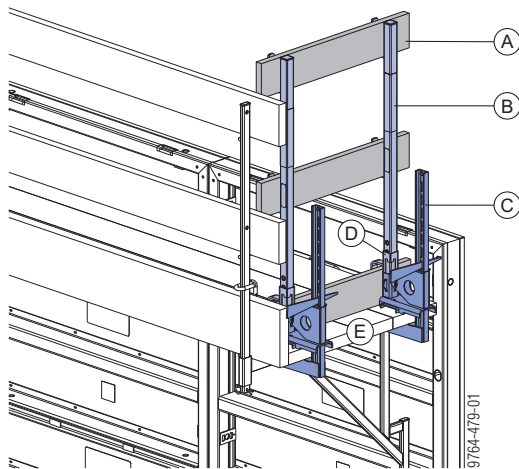

**A** Guard-rail board min. 15x3 cm (site-provided)

**B** Handrail post XP 1.20m

**C** Railing clamp XP 40cm

**D** Toeboard holder XP 1.20m

**E** Pouring platform

#### How to mount:

- ▶ Fasten Railing clamps XP onto the decking of the pouring platform, by tightening the wedge (clamping range 2 to 43 cm).
- ▶ Working from below, push a Toeboard holder XP 1.20m onto the Handrail post XP 1.20m.
- ▶ Push the Handrail post XP 1.20m into the post-holding fixture on the Railing clamps XP until the locking mechanism engages.
- ▶ Fix guard-rail boards to the handrail post plates with nails (diam. 5 mm).

Animation:

<https://player.vimeo.com/video/276197020>

### Handrail clamp S



Follow the directions in the “Handrail clamp S” User information!

## Opposing guardrail

If there are work platforms mounted on one side of the formwork only, then a fall-protection barrier must be mounted to the opposing formwork.

**Note:**

The plank and board thicknesses stated comply with the EN 338 C24 timber..

Observe all national regulations applying to deck and guardrail boards.

## Xsafe edge protection XP

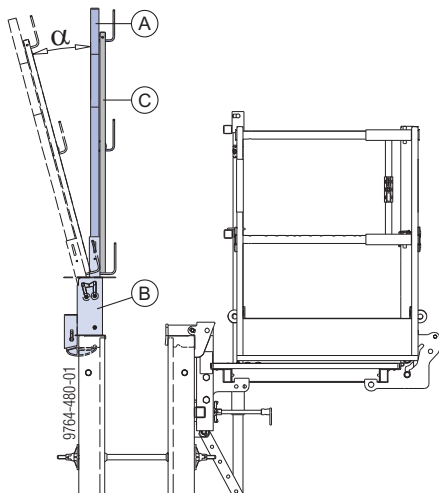

$\alpha$  ...15°

- A Handrail post XP 1.20m
- B Framax adapter XP
- C Protective grating XP or guardrail boards

If necessary (e.g. to enlarge the available work-space during pouring), the safety barrier can be tilted outward by 15°.

► Push up the safety bolt on the Adapters XP until the spring snaps into place (allow for overlap between protective gratings and/or guardrail boards).

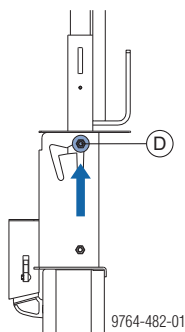

- D Safety bolt

► Tilt the safety barrier outward.

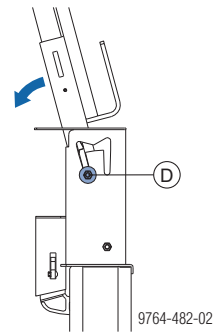

- D Safety bolt

The safety bolt now automatically drops and secures the tilted barrier unit.



Do a sight-check to make sure that the safety bolt is in the correct position!

### Types of safety barrier:

	Protective grating XP	Guardrail boards
Handrail post XP 1.20m		
Handrail post XP 0.60m		

- a ... 143 cm
- b ... 93 cm
- c ... min. 100 cm
- d ... 103 cm
- e ... 106 cm

- E Handrail post XP 1.20m
- F Handrail post XP 0.60m
- G Protective grating XP 1.20m
- H Protective grating XP 0.60m
- I Platform decking
- J Guardrail board min. 15 cm (site-provided)



**NOTICE**

- Note the necessary minimum distance of 100 cm from platform decking to top of railing!
- When Handrail posts XP 1.20m and guard-rail boards are used to construct the safety barrier, it is not permissible to install guard-rail boards in the top railing shackles!

**Assembly**

The opposing guard-rail can be mounted to both upright and face-down (ground-assembled) gang-forms.



**NOTICE**

- ▶ Do not position the Framax adapter XP directly over a lifting edge!

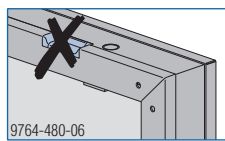

- ▶ Mount the Framax adapter XP on the frame profile and fix it in place with the wedge.

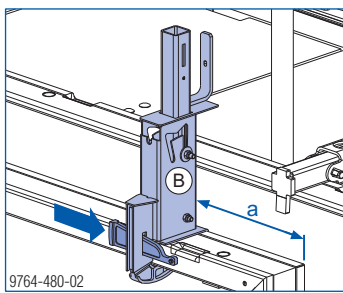

a ... ca. 35 cm (position of the two endmost Framax adapters XP on a gang-form)

**B** Framax adapter XP

- ▶ Push the handrail post XP into the post-holding fixture on the Framax adapter XP until the locking mechanism engages.
- ▶ Fit on a Protective grating XP or guardrail boards.
- ▶ Use Velcro® fasteners 30x380mm to secure the Protective gratings XP to the Handrail posts XP, or use nails (diam. 5 mm) to secure guardrail boards.

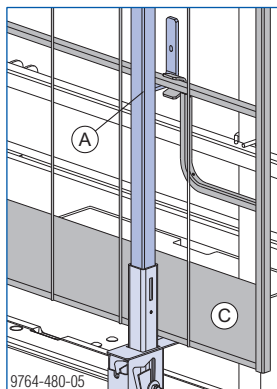

**A** Handrail post XP

**C** Protective grating or guardrail boards

**Lifting by crane**

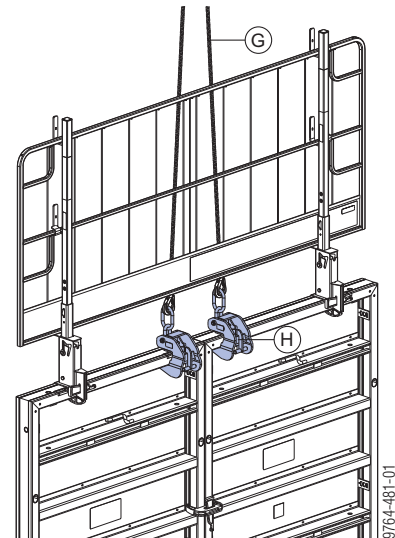

**G** Doka 4-part chain 3.20m

**H** Framax lifting hook

**When lifting gang-forms together with opposing guardrails assembled from the Xsafe edge protection XP, remember the following points:**

- The guard rails must be in the vertical position when the gang-form is raised or laid down.
- Elastic deformation of the guard rails may occur because the 4-part chain is resting against the protective grating or guardrail boards while the gang-form is being lifted.
- When a gang-form is lifted, repositioned or laid down, the 4-part chain must not be led around the protective grating or the guardrail board.

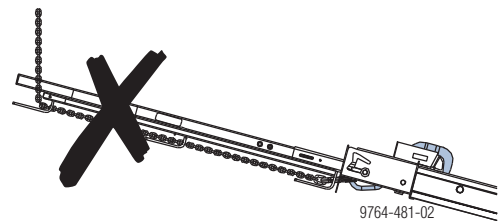

**Make sure that the 4-part chain is in the right position:**

- Placing down onto the form-ply side
- Picking up from this position

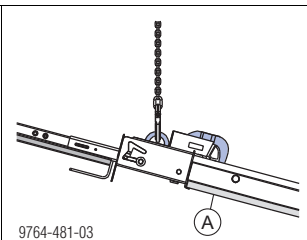

- Placing down onto the back-face of the formwork (e.g. for cleaning the form-facing)
- Picking up from the cleaning position
- Repositioning the upright gang-form

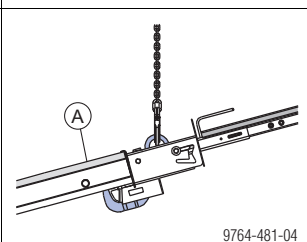

**A** Form-ply side

## Structural design

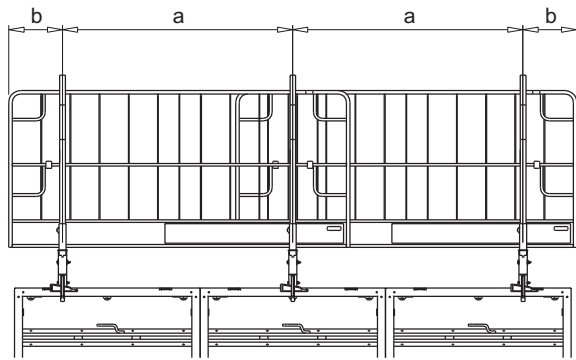

a ... span  
b ... cantilever

### Note:

The wind conditions likely to be encountered in Europe, in accordance with EN 13374, are largely recognised by the peak velocity pressure  $q=0.6 \text{ kN/m}^2$  (highlighted in the tables).

### Permitted span (a)

		Peak velocity pressure q [kN/m <sup>2</sup> ]			
		0.2	0.6	1.1	1.3
Permitted span	Protective grating XP	2.5 m		-	
	Guardrail board 2.4 x 15 cm	1.9 m			
	Guardrail board 3 x 15 cm	2.7 m			
	Guardrail board 4 x 15 cm	3.3 m			

### Permitted cantilever (b)

		Peak velocity pressure q [kN/m <sup>2</sup> ]			
		0.2	0.6	1.1	1.3
Permitted cantilever	Protective grating XP	0.6 m		0.4 m	-
	Guardrail board 2.4 x 15 cm	0.5 m			
	Guardrail board 3 x 15 cm	0.8 m			
	Guardrail board 4 x 15 cm	1.4 m			

## Handrail post 1.10m

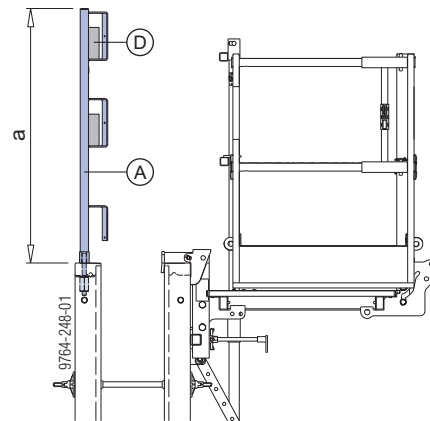

a ... 120 cm

A Handrail post 1.10m

D Guard-rail board

### How to mount:

- Fix the Guard rail 1.10m into the cross borehole of the framed panel with a hexagon nut 20.0.

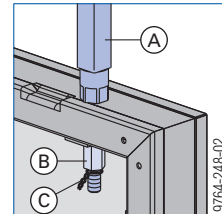

A Handrail post 1.10m

B Hexagon nut 20.0

C Hexagon nut secured by e.g. binding wire

- Secure the Hexagon nut 20.0.



### NOTICE

Before the gang-form is repositioned by crane, the guard-rail boards must be removed!



Follow the directions in the 'Handrail post 1.10m' User Information!

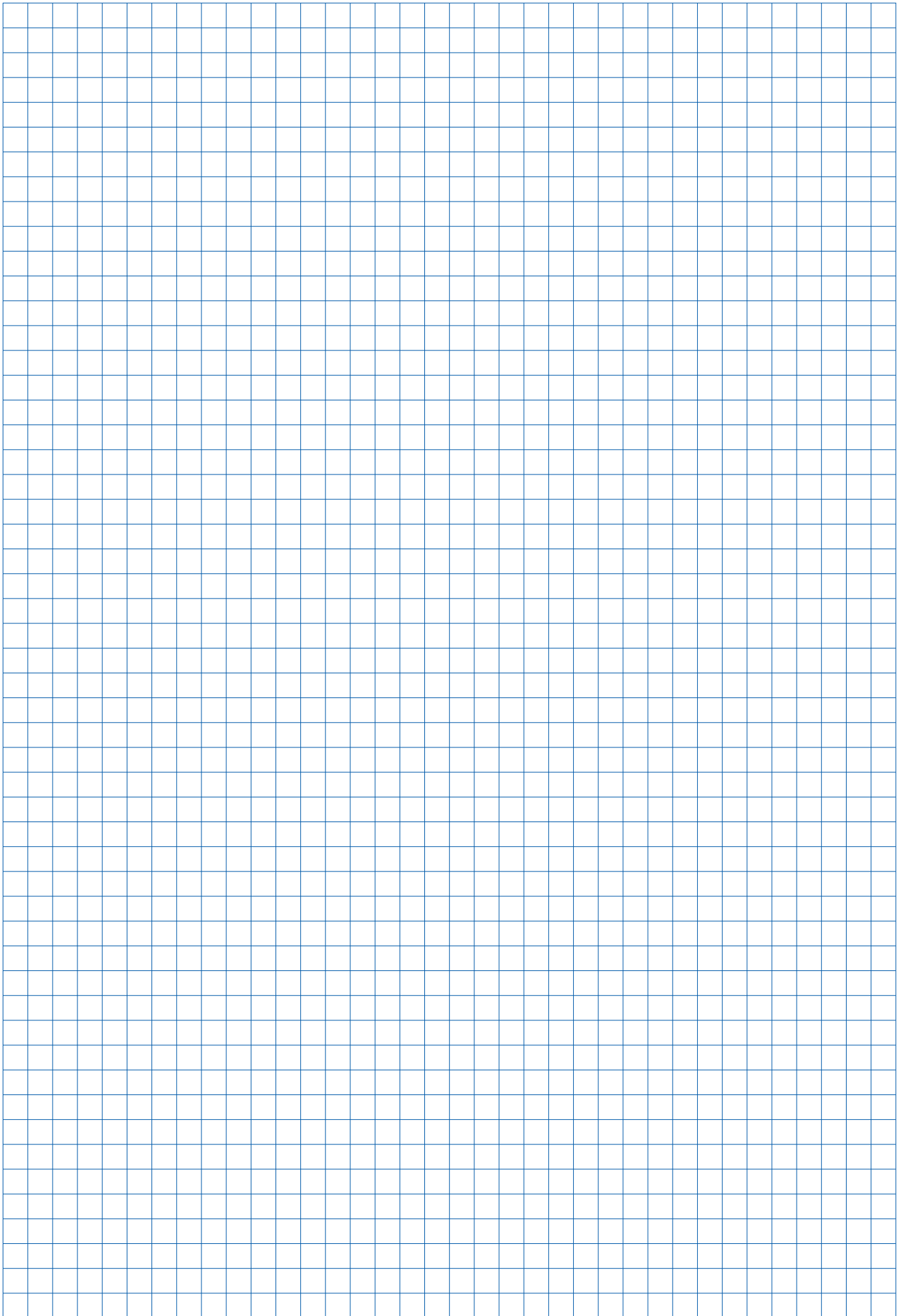

# Wall formwork at the edge of the structure

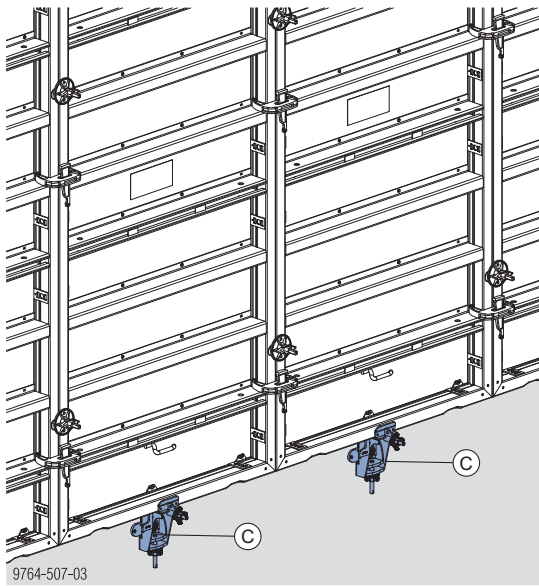

**C** Wall-formwork support angle 2G or Wall-formwork support angle

## Wall-formwork support angle 2G

The **Wall-formwork support angle 2G** is used for positioning wall formwork at the edge of the structure if there is no suitable load-bearing base (e.g. platform). It offers a dual function with which the support angle can be secured either with a Bridge edge beam anchor 15.0 or alternative anchorages.

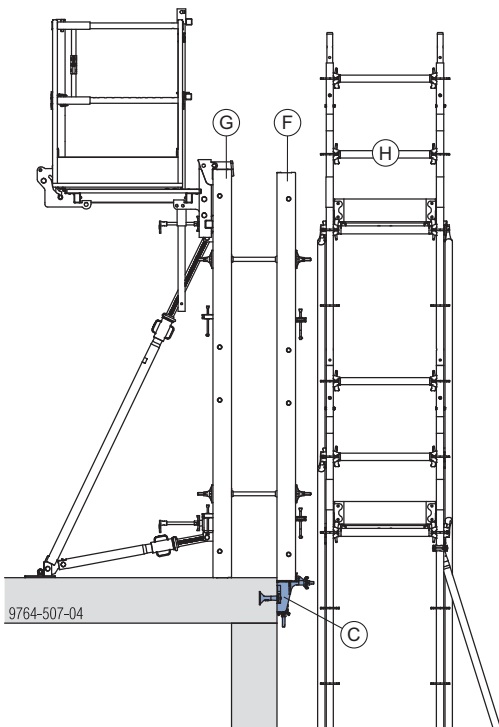

**C** Wall-formwork support angle 2G

### Possible anchorages:

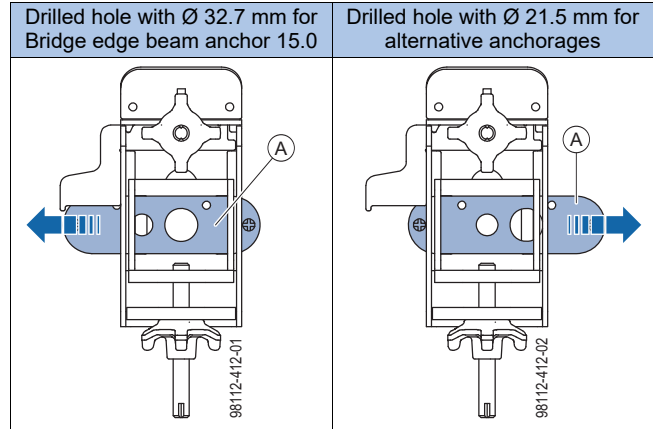

**A** Plate for pushing to the respective drilled hole

### Drilled hole with Ø 32.7 mm for Bridge edge beam anchor 15.0:

	Permissible load-bearing capacity per Wall-formwork support angle 2G: (Values apply to uncracked concrete)	
	Characteristic cube compressive strength of the concrete $f_{ck,cube,existing}$	
	10 N/mm <sup>2</sup> (C 8/10)	15 N/mm <sup>2</sup> (C 12/15) or higher
Maximum load $F_{permissible}$	16.7 kN	20.0 kN



### NOTICE

- Installation of the support angle is done by crew members working from the leading façade scaffold!

### Note:

A **Bridge edge beam anchor 15.0** has to be set into the concrete when the preceding section is poured so that the support angle can be secured to it.



Follow the directions in the 'Bridge edge beam anchor 15.0' User Information booklet.

### Drilled hole with Ø 21.5 mm for alternative anchorage:

		Maximum load $F_{permissible}$ [kN]			
		5.0	10.0	15.0	20.0
Resulting minimum resistances of the alternative anchorage from the load $F_{permissible}$	Characteristic tensile force $N_{R,k}$	4.5	9.0	13.5	17.9
	Design tensile force $N_{R,d}$	6.7	13.5	20.2	26.9
	Characteristic shear force $V_{R,k}$	5.0	10.0	15.0	20.0
	Design shear force $V_{R,d}$	7.5	15.0	22.5	30.0



**NOTICE**

- Statical verification is required!
- Installation of the support angle is done by crew members working from the leading façade scaffold!
- The alternative anchorages must be selected not only according to the forces but also according to the compressive strength of the concrete and the minimum distances.

**Installation:**

- Remove the nailing cone from the bridge edge beam anchor.

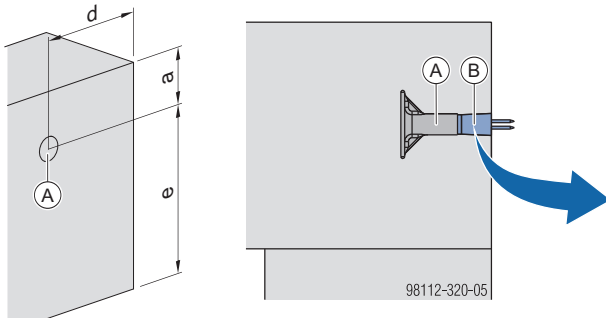

a ... min. 11.0 up to max. 14.0 cm  
 d ... min. 15 cm  
 e ... min. 45 cm

- A** Bridge edge beam anchor 15.0
- B** Nailing cone 15.0

- 1) Secure the support angle to the bridge edge beam anchor with a Screw-in cone 15.0 (but do not yet tighten).
- 2) Use the lower vertical star grip nut to adjust to the necessary level (b).
- 3) Tighten the Screw-in cone 15.0.

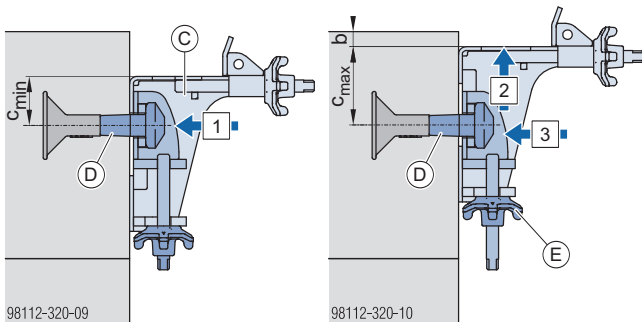

b ... offset approx. 1.0 cm  
 (so that the formwork can be tightened against the wall/slab)

	Bridge edge beam anchor 15.0	Alternative anchorage
$c_{min}$ ...	6.5 cm	6.0 cm
$c_{max}$ ...	11.5 cm	12.0 cm
Max. adjustment range ...	5.0 cm	6.0 cm

- C** Wall-formwork support angle 2G
- D** Screw-in cone 15.0
- E** Star grip nut vertical



Check that the support angle is correctly seated flat against the wall.

- 4) Place the formwork on the support angle.

- 5) Press the formwork against the structure using the upper horizontal star grip nut.

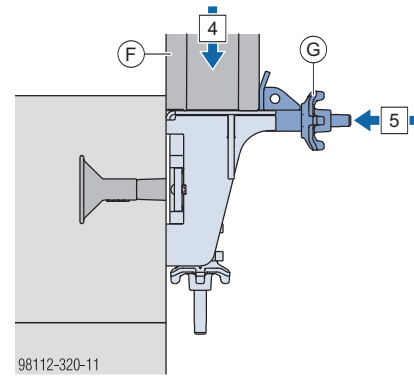

- F** Formwork
- G** Star grip nut horizontal

- 6) Secure the formwork on the support angle with Framax multi function clamp or Framax adjustable clamp to prevent lifting out.

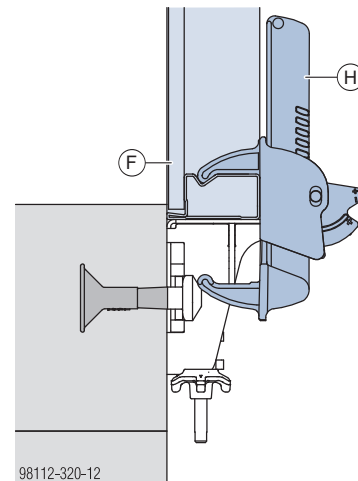

- F** Formwork
- H** Framax multi function clamp or Framax adjustable clamp

## Wall-formwork support angle

The **Wall-formwork support angle** is a support for positioning wall formwork at the edge of the structure if there is no suitable load-bearing base (e.g. platform).

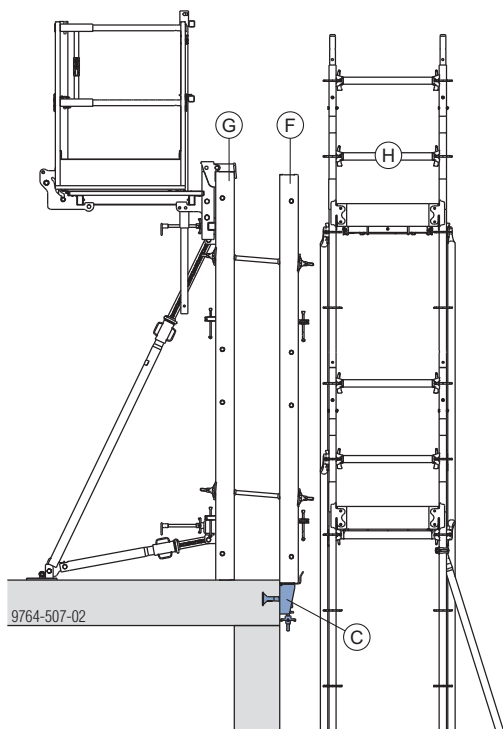

- C** Wall-formwork support angle
- F** Opposing formwork
- G** Holding formwork
- H** Façade scaffolding (e.g. Working scaffold Modul)

### Drilled hole with Ø 32.7 mm for Bridge edge beam anchor 15.0:

	Permissible load-bearing capacity per Wall-formwork support angle 2G: (Values apply to uncracked concrete)	
	Characteristic cube compressive strength of the concrete $f_{ck, cube, existing}$	
	10 N/mm <sup>2</sup> (C 8/10)	15 N/mm <sup>2</sup> (C 12/15) or higher
Maximum load $F_{permissible}$	16.7 kN	20.0 kN



#### NOTICE

- Installation of the support angle and tying of the panels are jobs undertaken by crew members working from the leading façade scaffolding!

#### Note:

A **Bridge edge beam anchor 15.0** has to be set into the concrete when the preceding section is poured so that the support angle can be secured to it.



Follow the directions in the 'Bridge edge beam anchor 15.0' Fitting Instructions.

### Installation:

- Remove the nailing cone from the bridge edge beam anchor.

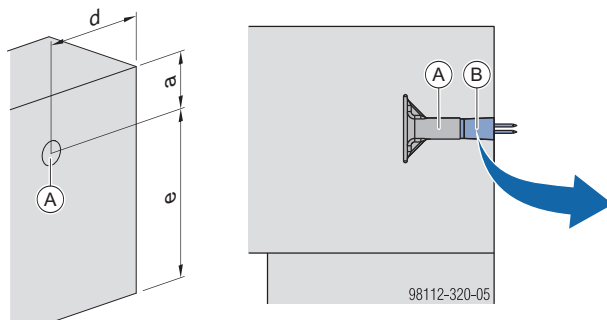

- a ... min. 11.0 up to max. 14.0 cm
- d ... min. 15 cm
- e ... min. 45 cm

- A** Bridge edge beam anchor 15.0
- B** Nailing cone 15.0

- 1) Secure the support angle to the bridge edge beam anchor with a Screw-in cone 15.0 (but do not yet tighten).
- 2) Use the star grip nut for adjusting to the necessary level (b).
- 3) Tighten the Screw-in cone 15.0.

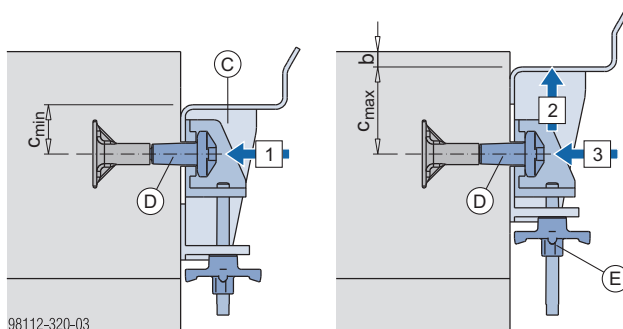

- b ... offset approx. 1.0 cm  
(so that the formwork can be tightened against the wall/slab)
- Adjustment range  $c_{min}$  ... 6.5 to  $c_{max}$  ... 11.5 cm = 5 cm

- C** Wall-formwork support angle
- D** Screw-in cone 15.0
- E** Star grip nut



Check that the support angle is correctly seated flat against the wall.

- 4) Position the holding formwork.
- 5) Lower the opposing formwork on to the support angle by crane.

- 6) Use a wedge to tighten the formwork against the wall/slab.

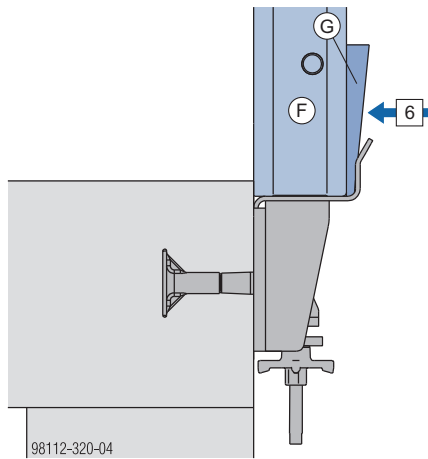

F Opposing formwork

G Wedge

- 7) Fit the anchors.



Before disconnecting from the crane:

▶ Do not disconnect the panel from the crane until a large enough number of form ties have been installed to keep it safely in the upright.

- 8) Detach the gang-form from the crane.

## Ladder system

The Ladder system XS permits safe vertical access to and from the intermediate platforms and pouring platforms:

- when attaching/detaching the formwork to/from the crane tackle
- when opening/closing the formwork
- when placing the reinforcement
- during pouring

### Note:

The ladder system must be implemented in such a way that all national regulations are complied with.



### CAUTION

- ▶ The Ladders XS may only be used as part of the system, and must NOT be used separately (as 'lean-to' ladders).

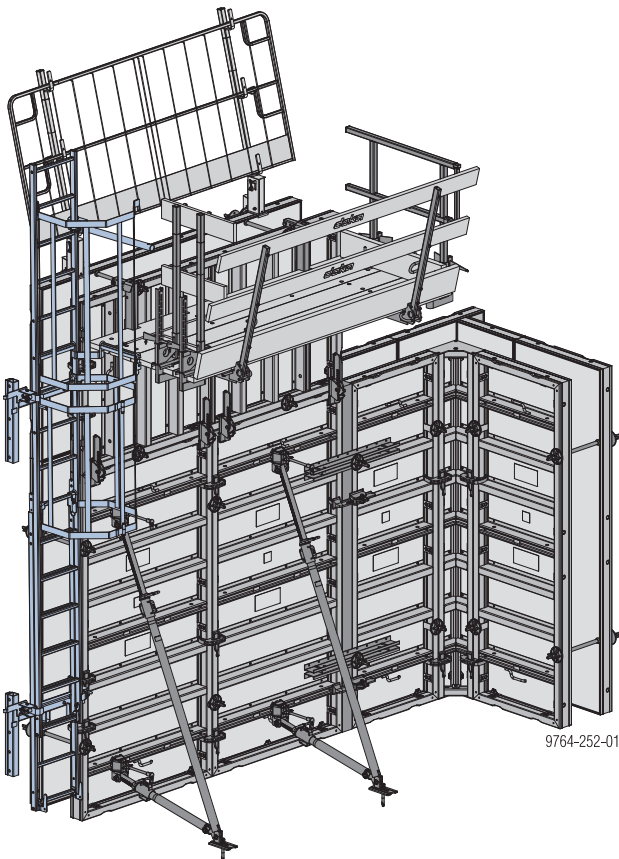

## Assembly

### Preparing the formwork

- ▶ Pre-assemble gang-forms face-down on a prepared flat area (see the section headed [Inter-panel connections](#)).
- ▶ Install platforms and panel struts on the laid-flat panel (see the sections headed [Pouring platforms](#) and [Plumbing accessories](#)).

### Attaching connectors to the formwork

- ▶ Place the Connector XS Wall formwork against the frame profile near the top of the formwork.
- ▶ Fasten the Connector XS Wall formwork to the frame profile using two Quick acting clamps RU.

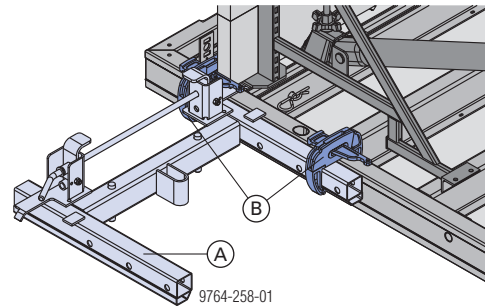

- A Connector XS wall formwork
- B Quick acting clamps RU

- ▶ Place a Connector XS wall formwork against the frame profile, near the bottom of the formwork.
- ▶ Fasten the Connector XS Wall formwork to the frame profile using two Quick acting clamps RU.

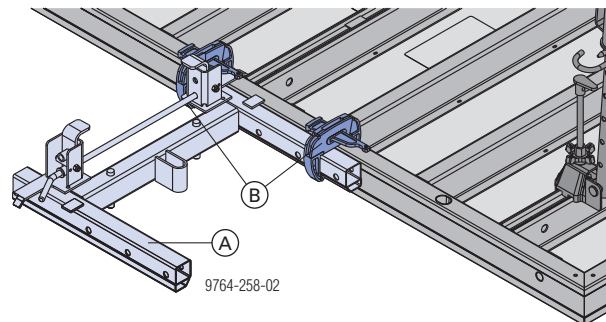

- A Connector XS wall formwork
- B Quick acting clamps RU

- ▶ For formwork heights above 5.85 m, an extra Connector XS Wall formwork must be attached in the same way near the middle of the formwork (i.e. approx. half-way up).

This extra connector prevents the ladder swaying when site crew climb up or down it.

## Fixing the ladder

### to the top Connector XS Wall formwork

- ▶ Pull out the push-in bolt, and pivot the two safety hooks out of the way.
- ▶ Place the System ladder XS 4.40m onto the Connector XS, with the hooking brackets facing downwards.
- ▶ Close the safety hooks.
- ▶ Insert the push-in bolt into whichever rung of the ladder is suitable for the height of the formwork, and secure it with a linch pin.

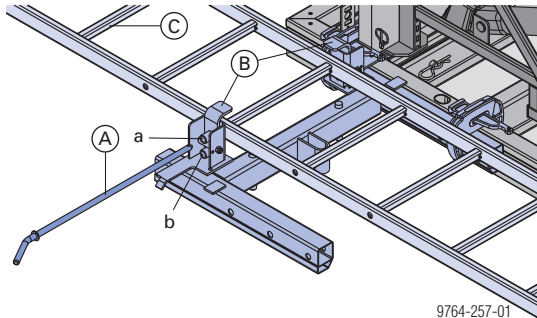

- in the front position (a)

- A** Push-in bolt
- B** Safety hooks
- C** System ladder XS 4.40m

Animation:

<https://player.vimeo.com/video/274425011>

### to the bottom Connector XS Wall formwork

- ▶ Pull out the push-in bolt, pivot both safety hooks out of the way, and place the ladder onto the Connector XS.
- ▶ Close the safety hooks, re-insert the push-in bolt and secure it with a linch pin.

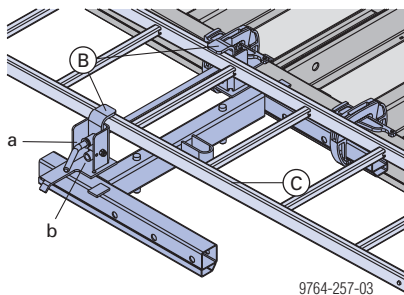

- in the front position (a) for one single ladder

- in the rear position (b) in the telescoping zone (for 2 ladders)

- B** Safety hooks
- C** Ladder XS

Animation:

<https://player.vimeo.com/video/274427263>

- ▶ Mount the Securing barrier XS to the ladder, with fixing hooks and wing-nuts.

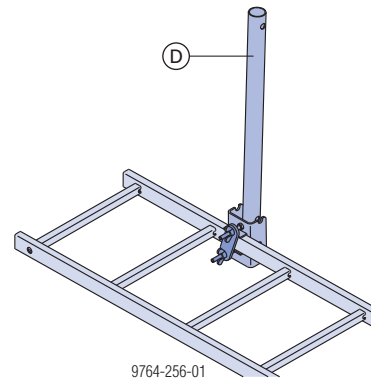

- D** Securing barrier XS

The components needed for mounting the Securing barrier XS are captively attached to it.

## Ladder system XS for heights above 3.75 m

### Telescoping ladder extension (for adjusting to ground level)

- ▶ To telescope the ladders past one another, lift the safety latch on the ladder and fix the Ladder extension XS 2.30m onto the desired rung of the other ladder.

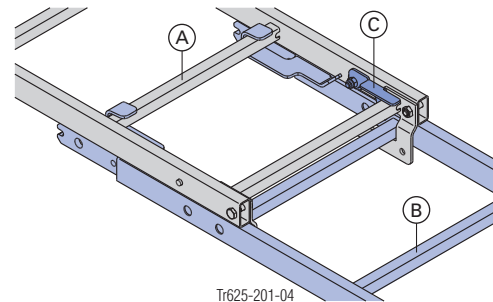

### Close-up

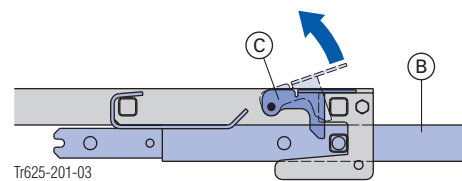

- A** System ladder XS 4.40m
- B** Ladder extension XS 2.30m
- C** Securing latch

A telescoping joint between two Ladder extensions XS 2.30m can be made in the same way.

**Permanently fixed ladder extension**

- ▶ Insert the Ladder extension XS 2.30m into the uprights of the System ladder XS 4.40m, with its hooking brackets facing downwards, and fasten it. Tighten the screws only **slightly!**

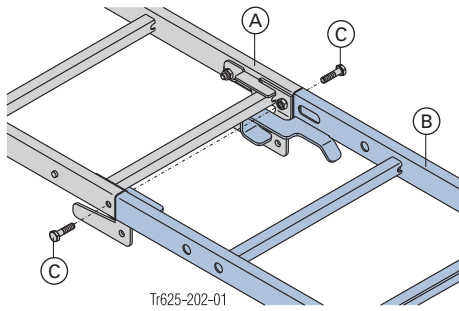

Bolts (C) are included in the scope of supply of the System ladder XS 4.40m and the Ladder extension XS 2.30m.

- A System ladder XS 4.40m
- B Ladder extension XS 2.30m
- C Hexagon bolt M10x40

Two Ladder extensions XS 2.30m can be fixed together in the same way.



**NOTICE**

- ▶ Always observe all relevant safety regulations applying to the use of the Ladder cage XS in the country in which you are operating (e.g. in Germany: BGV D 36).

- ▶ Attach the Ladder cage exit XS (the bottom of the cage must always be at the same height as the platform). The safety latches prevent the cage from being accidentally lifted out.

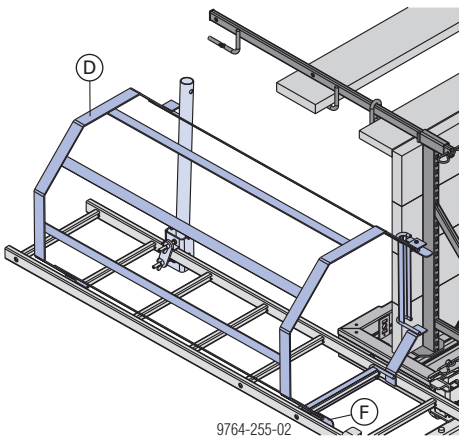

- D Ladder cage exit XS
- F Safety latch (lift-out guard)

- ▶ Attach the Ladder cage XS to the next available rung. Attach further ladder cages, in each case to the next available rung.

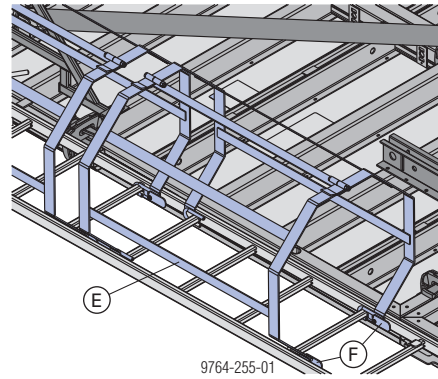

- E Ladder cage XS
- F Safety latches (lift-out guard)

**Connection in the function profile**

Mounting the Ladder system XS to the function profile makes it an integral part of the gang-form.

**Plan view**

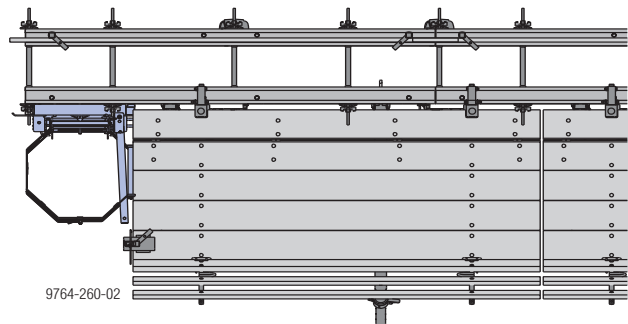

**Installation:**

- ▶ Fix the Connector XS Wall formwork to the function profile with a Fixing clamp XS Framax.

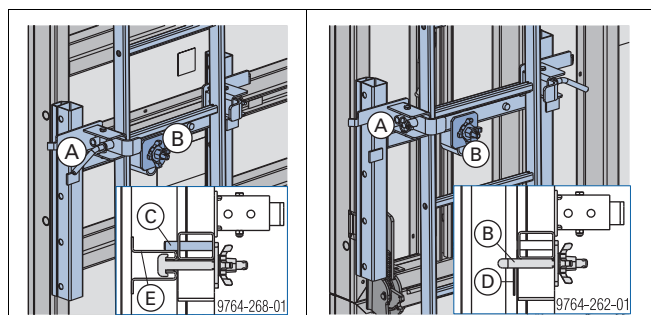

**Anti-slide-off guard**

Two pins (C) resting on the function profile (E)

Fixing clamp XS Framax (B) resting on the frame profile or on one of the drawn metal sheets (D)

- A Connector XS Wall formwork
- B Fixing clamp XS Framax

## Items needed

Connectors + ladder	Formwork height		
	2.70-3.75 m	>3.75-5.85 m	>5.85-8.10 m
Connector XS Wall formwork	2	2	3
Quick acting clamp RU or Fixing clamp XS Framax <sup>1)</sup>	4	4	6
System ladder XS 4.40m	1	1	1
Ladder extension XS 2.30m	0	1	2

<sup>1)</sup> When connected in the function profile

Ladder cage	Formwork height					
	2.70-3.15 m	>3.15-4.05 m	>4.05-5.40 m	>5.40-6.60 m	>6.60-7.65 m	>7.65-8.10 m
Ladder cage exit XS <sup>2)</sup>	1	1	1	1	1	1
Securing barrier XS <sup>2)</sup>	1	1	1	1	1	1
Ladder cage XS 1.00m <sup>2)</sup>	0	1	2	3	4	5

<sup>2)</sup> This does not take account of any intermediate exits.

## Exit onto an intermediate platform

### Note:

- The number of Connectors XS wall formwork and ladder components is shown in the table [Items needed](#).
- For each additional exit, one Ladder cage exit XS and one Securing barrier XS are required.
- Any over-large openings above the intermediate exit must be reduced with a Ladder cage XS 0.25m.

### Mounting the Ladder cage XS 0.25m

- ▶ Hook the ladder cage into an empty rung and secure it against accidental lift-out.

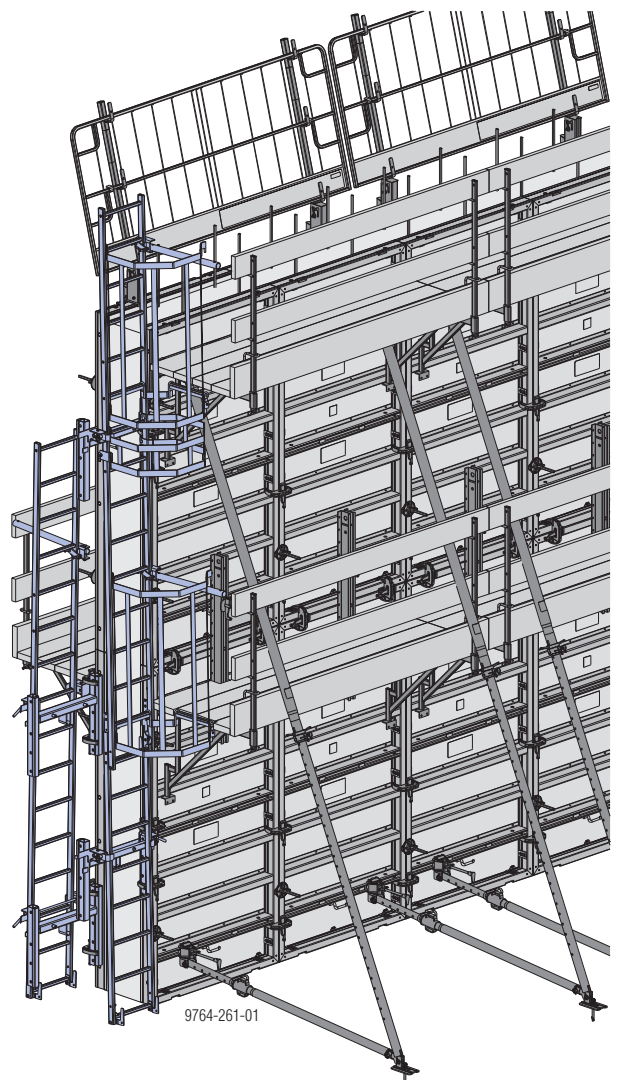
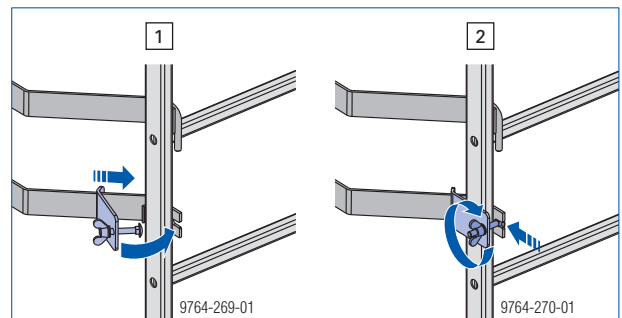

# Tools for plumbing and aligning and for stripping the formwork



**NOTICE**

In preparation for plumbing and aligning or stripping, secure the panel or gang-form so that it cannot tip over (e.g. attach to the crane or secure with panel struts)

## Framax positioning lever

The **Framax positioning lever** is a tool for plumbing and aligning the framed formwork and detaching the framed formwork from the hardened concrete.

**Note:**

Using the positioning lever to detach the formwork leaves impressions in the concrete. If impressions in the concrete are unacceptable: Use the Framax stripping tool!

- ▶ Engage the Framax positioning lever in the bottom-most cross borehole of the framed formwork.

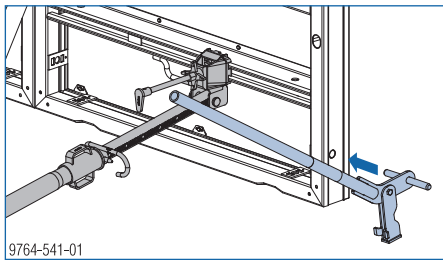

- ▶ Plumb and align the framed formwork or lever it away from the concrete, as applicable.

**Plumbing and aligning the framed formwork:**

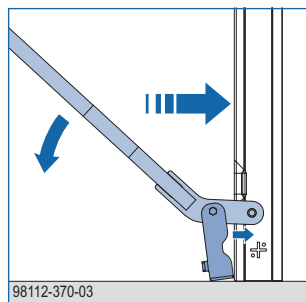
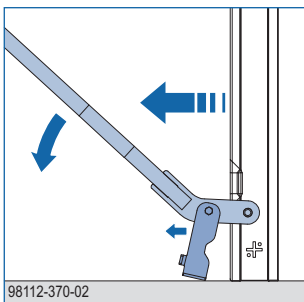

**Detaching formwork from the concrete:**

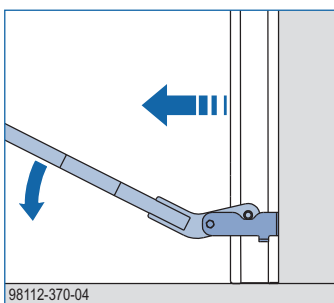

## Framax stripping tool

The **Framax stripping tool** is for detaching the framed formwork from the hardened concrete.

- ▶ Position the Framax stripping tool into a cross bore-hole of the framed formwork.

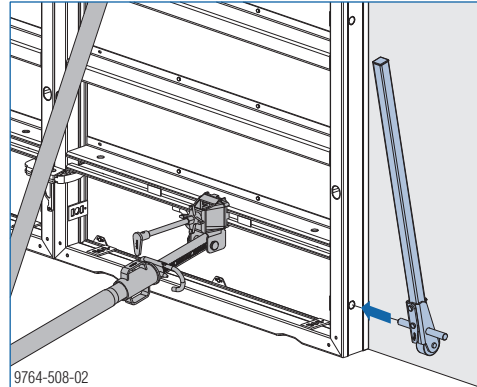

- ▶ Lever the framed formwork away from the concrete.

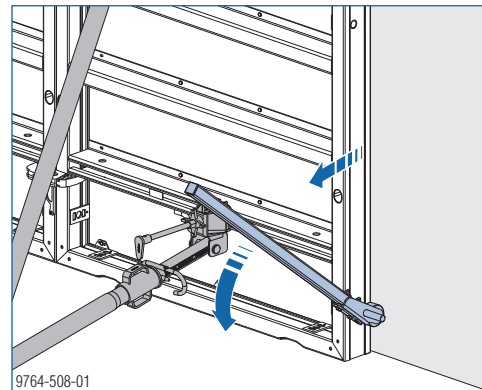

## Framax stripping aid

The **Framax stripping aid** is for detaching a framed panel from the hardened concrete by pressing against the neighbouring panel.

- ▶ Engage and position two Framax stripping aids in the function profile.

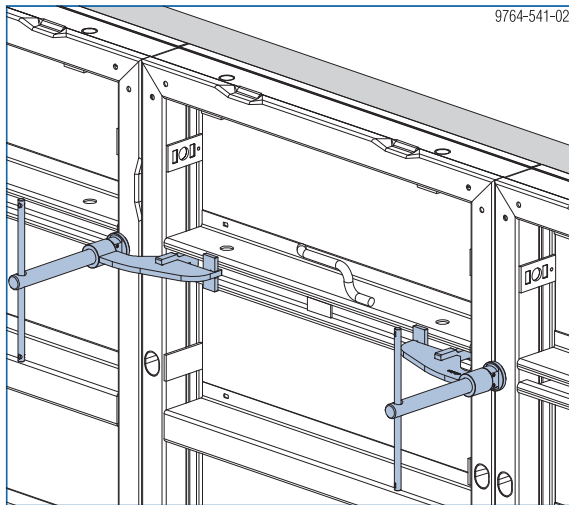

The spindles of the Framax stripping aids act against the frame profile of the neighbouring panel on each side.

- ▶ Detach the framed panel from the concrete by tightening both spindles at the same time.

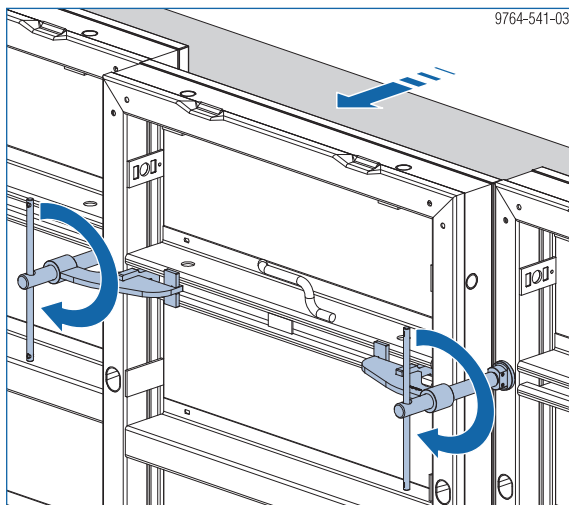

## Lifting by crane

Safe crane-handling of Framax Xlife is possible using the **Doka 4-part chain 3.20m** and the **Framax lifting hook**. The lifting hook locks automatically after being hung into place.

### Doka 4-part chain 3.20m

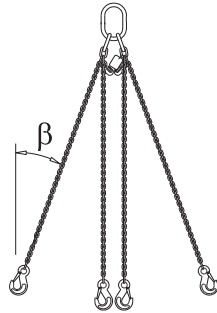

CE

- ▶ Attach the Doka 4-part chain 3.20m to the Framax lifting hooks.
- ▶ Hang the remaining chain-lengths back in place.

**Permissible working load limit (2-part chain):**  
Up to 30° sling angle  $\beta$  2400 kg.



Follow the Operating Instructions!

### Framax lifting hook

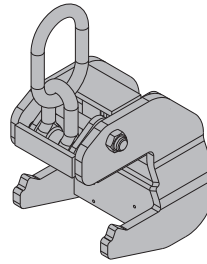

CE

#### Permissible working load limit:

- Sling angle  $\beta$  up to 30°:  
1000 kg (2200 lbs) / Framax lifting hook
- Sling angle  $\beta$  up to 7.5°:  
1500 kg (3300 lbs) / Framax lifting hook

Framax lifting hooks with permissible working load limit of 1000 kg (2200 lbs) also meet the requirements for a working load limit of 1500 kg (3300 lbs) max. using a sling angle  $\beta \leq 7.5^\circ$ .



Follow the Operating Instructions!



On larger gangs, use **Framax lifting hooks 25kN** or **Framax lifting hooks 20kN** together with a **two-part lifting chain with sufficient working load limit**.

Follow the directions in the 'Framax lifting hook 25kN' Operating Instructions!

Follow the directions in the 'Framax lifting hook 20kN' Operating Instructions!

### Securing the lifting hooks against sliding from side to side



#### NOTICE

Position the lifting hooks so that they are secured against sideways slippage.

- over **inter-panel joints**
- over **cross profiles** (single panel installed on its side)
- over **centre profiles**
- over **welded-on metal plates**

For other suitable positions see the section headed [Position of the lifting hooks](#).

## Position of the lifting hooks

### Note:

The positions of the lifting hooks shown here also apply for vertically stacked gang-forms.

### Single panel:

Panels up to 0.60m wide

Panels over 0.60m wide

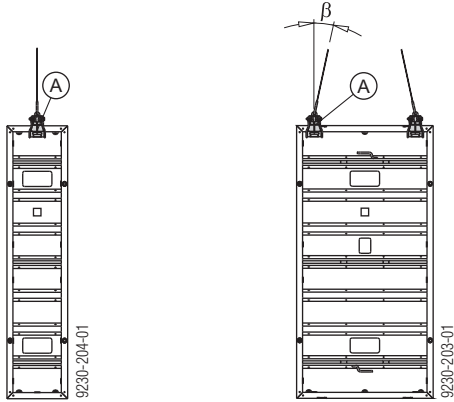

A Welded-on metal plate

Extra-large panel

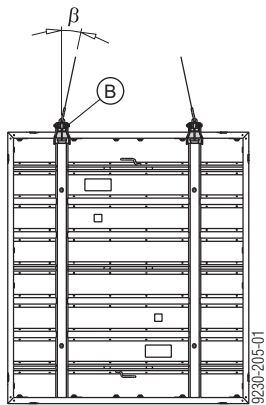

B Centre profile

### Gang-form - two panels upright:

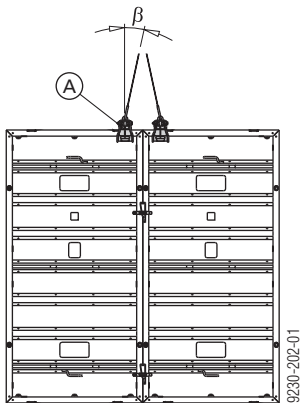

A Welded-on metal plate

### Gang-form - three (or more) panels upright:

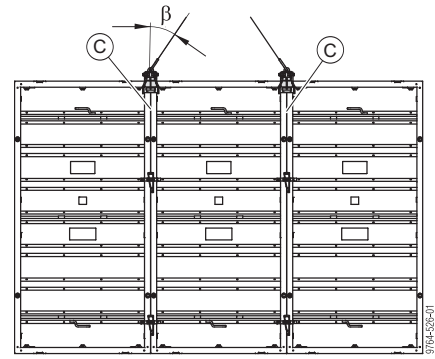

C Inter-panel joint

### Gang-form - panel on its side (vertically stacked):

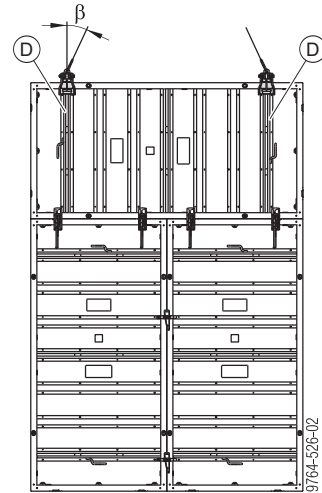

D Cross profile

## Assembling tool

For operation of the lifting hook on upright formwork by operator on ground level.



### CAUTION

**Risk of the lifting hook falling when operated with assembling tool!**

- ▶ With the crane, position the lifting hook level with the lifting point.

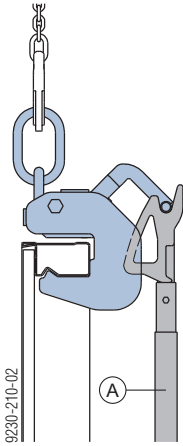

**Formwork height**

<b>A Framax telescopic assembling tool</b> (telescopes from 230 to 400 cm)	2.70 - 5.40m
<b>Framax assembling tool</b>	2.70 - 3.30m



In addition to operation of the lifting hook, the **Framax assembling tool** also offers the following functions:

- Pulling out double-headed nails
- Plumbing and aligning the formwork

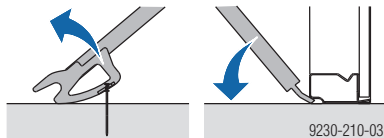

# Transporting, stacking and storing

## Bundling the panels

- 1) Position sleepers measuring approx. 8.0 x 10.0 (W x H) underneath the cross profile.
- 2) Strap the sleepers (hardwood blocking) and the bottom panel together with metal banding.

**WARNING**

The smooth surface of the powder-coated panels reduces the sticking friction.

- ▶ It is strictly forbidden to lift stacks of panels without inserting Framax stacking cones (2 cones per layer) first!

**Exception:** Stacking cones are not required if the stack is lifted using the Framax transport gear.

- 3) Insert Framax stacking cones.

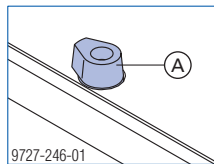

A Framax stacking cone

The stacking cones stop the panels slipping.

- 4) Strap the whole stack together tightly with strapping tape.

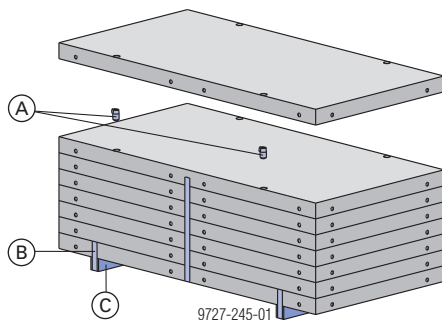

A Framax stacking cone  
B Strapping tape  
C Sleeper

Animation: <https://player.vimeo.com/video/267970071>

### Max. number of panels in a stack:

Panel	Max. number of panels stacked on top of one another	Stacking height incl. sleepers
up to 1.35x2.70m	8	approx. 110 cm
1.35x3.30m	5	approx. 75 cm
2.40x2.70m	5	approx. 75 cm
2.40x3.30m	4	approx. 60 cm
2.70x2.70m	4	approx. 60 cm
2.70x3.30m	4 *)	approx. 60 cm

\*) Stack weight in excess of 2000 kg: Consequently, Dokamatic lifting straps 13.00m or Framax transport bolts with a Doka 4-part chain 3.20m have to be used for lifting by crane.

## Transporting the panels

### Framax transport bolts with Doka 4-part chain 3.20m

The Framax transport bolts, in combination with the Doka 4-part chain 3.20m, are for hoisting individual stacks of panels and for separating the panels.

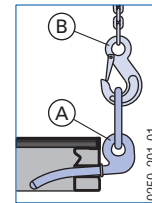

A Framax transport bolt  
B Doka 4-part chain 3.20m

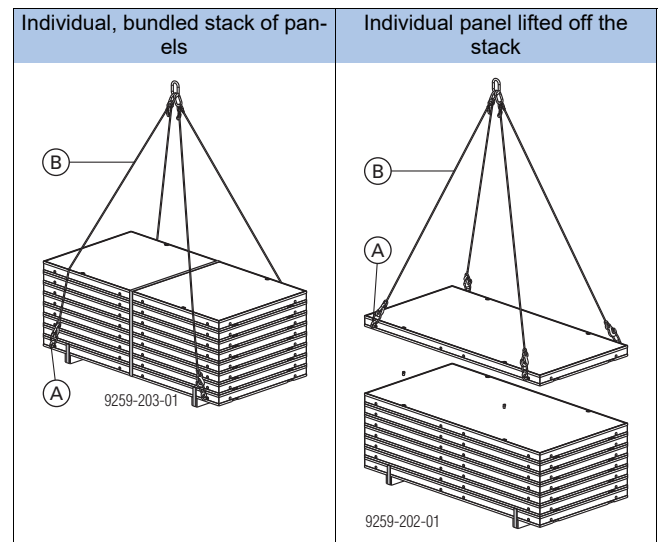

### Framax transport bolt:

Permissible working load limit: 800 kg / transport bolt  
Framax transport bolts manufactured until 2015, with a stated working load limit of 500 kg, are also capable of a working load limit of 800 kg.



Follow the Operating Instructions!

## Doka 4-part chain 3.20m

The Doka 4-part chain 3.20m is a multi-functional slinging means:

- used with the integrated **eye hooks** for hoisting formwork, platforms and multi-trip packaging containers.  
For more information, see the section headed [Lifting by crane](#).
- used in conjunction with **Framax transport bolts** for hoisting individual stacks of panels and for separating the panels.

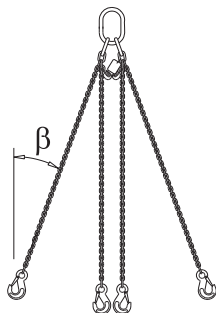

The Doka 4-part chain 3.20m can be adjusted to the centre-of-gravity position by shortening the length of individual chains.

### Permissible working load limit:

	Sling angle $\beta$			
	0°	0°-30°	30°-45°	45°-60°
Using one chain	1400 kg	-	-	-
Using two chains	-	2400 kg	2000 kg	1400 kg
Using all four chains	-	3600 kg	3000 kg	2120 kg



Follow the Operating Instructions!

## Dokamatic lifting strap 13.00m

The Dokamatic lifting strap 13.00m is a practical tool for **unloading and loading trucks**, and for **lifting and setting down individual stacks of panels**.

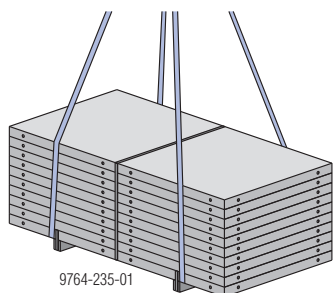

### Dokamatic lifting strap 13.00m:

Permissible working load limit: 2000 kg / lifting strap



Follow the Operating Instructions!

## Framax transport gear

For safe crane transport of individual stacks of panels at construction sites, depots etc.

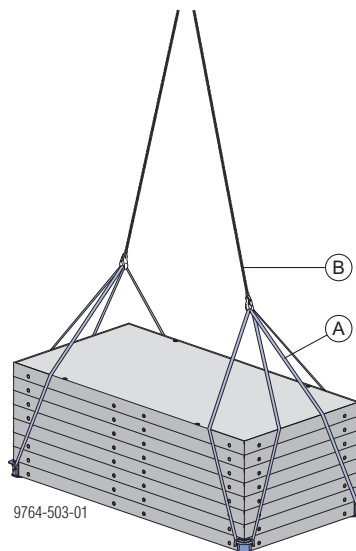

**A** Framax transport gear (consisting of 4 round slings)

**B** Chain suspension gear or Doka 4-part chain 3.20m

The four round slings of the transport gear hold the stack together on all four sides, in such a way that it is impossible for individual panels to slip out.

Benefits:

- Spring-loaded slinging hooks reach from underneath into the beads of the panel frame and prevent the transport gear accidentally detaching itself when the cable tension slackens.
- The automatic length compensation feature of the Framax transport gear ensures that the load is distributed evenly.
- The Framax transport gear can be suspended and detached by just one person working on their own.
- There is no need for anti-slippage protection using Framax stacking cones here.

### Framax transport gear

Permissible working load limit: 2000 kg / 4 round slings



**NOTICE**

- Max. stack height: 8 panels (incl. sleepers)
- The bottom layer of the stack may only consist of one panel.
- The stacks must always be of panels of equal width.
- The top layers may also consist of 'half-width' panels. The important thing here is that every panel must be held by at least two round slings and that no 'gaps' may be left open between panels.
- It is forbidden to transport stacks where the edges of the panels are not all in alignment!

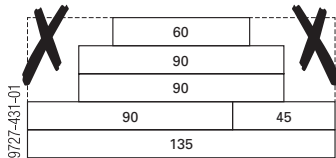

Follow the Operating Instructions!

## Lifting panels upright / turning panels over

- ▶ Use **Framax transport bolts** to lay the framed panel flat on squared timbers 20x20 cm

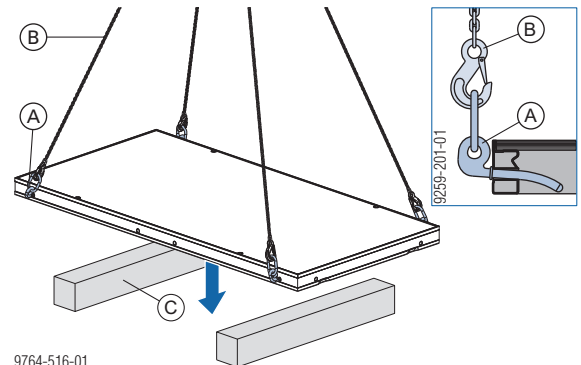

- A** Framax transport bolt
- B** Doka 4-part chain 3.20m
- C** Squared timber 20x20 cm



**WARNING**

Using Framax transport bolts to lift the framed panels upright or turn them over is prohibited!

- ▶ Use Framax lifting hooks!

- ▶ Position the Framax lifting hooks. Lift the framed panel upright with **Framax lifting hooks** and, if applicable, lay it flat with the sheeting side down.

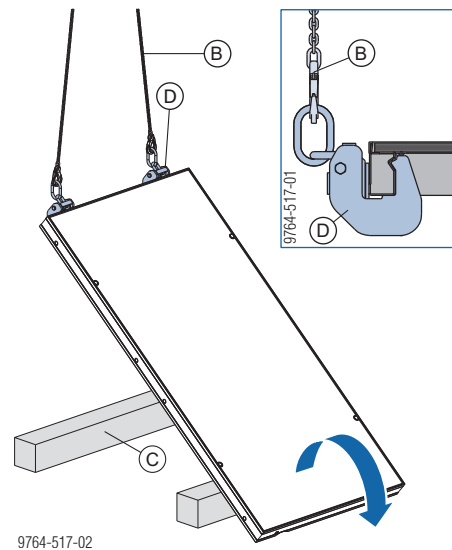

- B** Doka 4-part chain 3.20m
- C** Squared timber 20x20 cm
- D** Framax lifting hook



Follow the Operating Instructions!

**Utilise the benefits of Doka multi-trip packaging on your site.**

Multi-trip packaging such as containers, stacking pallets and skeleton transport boxes keep everything in place on the site, minimise time wasted searching for parts, and streamline the storage and transport of system components, small items and accessories.

**Doka skeleton transport box 1.70x0.80m**

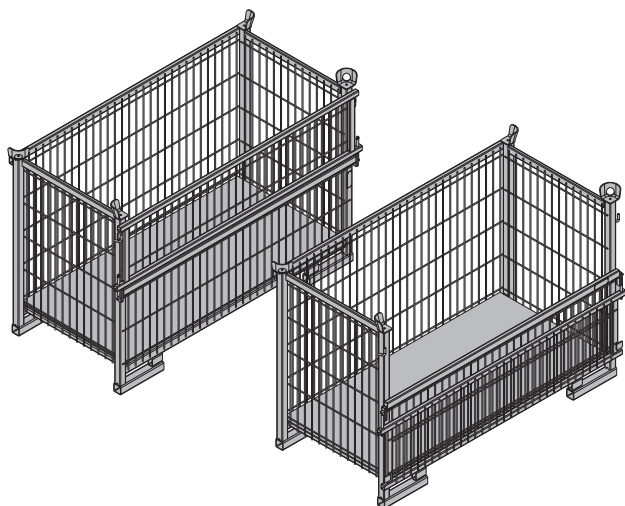

Storage and transport device for small items. To make the Doka skeleton transport box easier to load and unload, one of its sidewalls can be opened.

Permitted load-bearing capacity: 700 kg (1540 lbs)  
 Permitted imposed stacking load: 3150 kg (6950 lbs)

**Using Doka skeleton transport boxes 1.70x0.80m as storage units**

**Max. n° of units on top of one another**

Outdoors (on the site) Floor gradients up to 3%	Indoors Floor gradients up to 1%
2	5
It is not allowed to stack empty pallets on top of one another!	



**NOTICE**

Stacked multi-trip boxes or pallets must have the heaviest boxes at the bottom and the lightest at the top.

**Using Doka skeleton transport boxes 1.70x0.80m as transport devices**

**Lifting by crane**



**NOTICE**

- Multi-trip packaging items must be lifted individually.
- Only lift the boxes when their sidewalls are closed!
- Use suitable lifting chains:
  - e.g. Doka 4-part chain 3.20m
  - Do not exceed the permitted working load limit of the lifting chains.
- Sling angle  $\beta$  max. 30°!

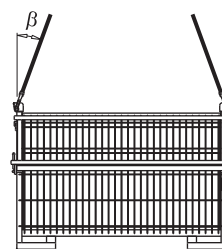

9234-203-01

**Repositioning by forklift truck or pallet stacking truck**

The forks can be inserted under either the broadside or the narrowside of the containers.

## Doka multi-trip transport box

Storage and transport device for small items

### Doka multi-trip transport box 1.20x0.80m

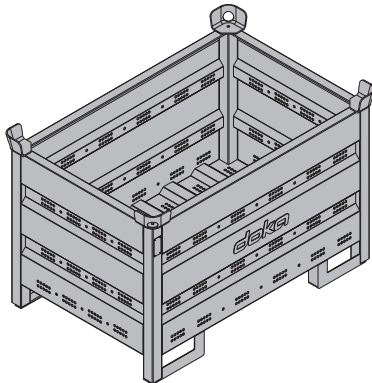

Permitted load-bearing capacity: 1500 kg (3300 lbs)  
Permitted imposed stacking load: 7850 kg (17300 lbs)

Different items in the Doka multi-trip transport box can be kept separate with the **Multi-trip transport box partitions 1.20m or 0.80m**.

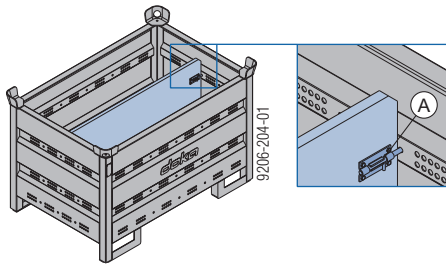

A Slide-bolt for fixing the partition

#### Possible ways of dividing the box

Multi-trip transport box partition	in the longitudinal direction	in the transverse direction
1.20m	max. 3	-
0.80m	-	max. 3

	
---	---

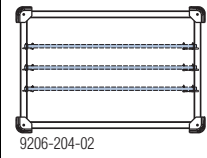
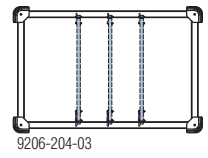
## Doka multi-trip transport box 1.20x0.80mx0.41m

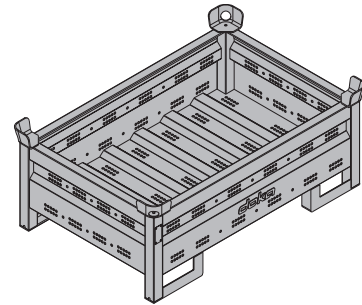

Permitted load-bearing capacity: 750 kg (1650 lbs)  
Permitted imposed stacking load: 7200 kg (15870 lbs)

### Using Doka multi-trip transport boxes as storage units

#### Max. n° of units on top of one another

Outdoors (on the site)		Indoors	
Floor gradients up to 3%		Floor gradients up to 1%	
Doka multi-trip transport box 1.20x0.80m	Doka multi-trip transport box 1.20x0.80x0.41m	Doka multi-trip transport box 1.20x0.80m	Doka multi-trip transport box 1.20x0.80x0.41m
3	5	6	10
It is not allowed to stack empty pallets on top of one another!			



#### NOTICE

Stacked multi-trip boxes or pallets must have the heaviest boxes at the bottom and the lightest at the top.

### Using Doka multi-trip transport boxes as transport devices

#### Lifting by crane



#### NOTICE

- Multi-trip packaging items must be lifted individually.
- Use suitable lifting chains:
  - e.g. Doka 4-part chain 3.20m
  - Do not exceed the permitted working load limit of the lifting chains.
- Sling angle  $\beta$  max. 30°!

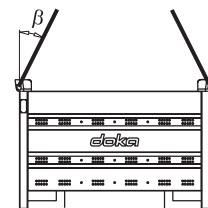

9206-202-01

#### Repositioning by forklift truck or pallet stacking truck

The forks can be inserted under either the broadside or the narrowside of the containers.

## Doka stacking pallet 1.55x0.85m and 1.20x0.80m

Storage and transport device for long items.

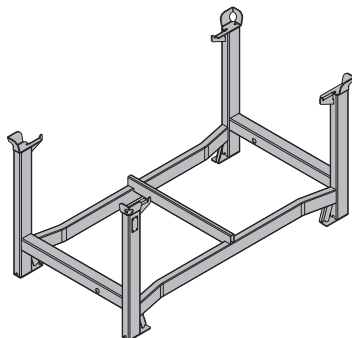

Permitted load-bearing capacity: 1100 kg (2420 lbs)  
 Permitted imposed stacking load: 5900 kg (13000 lbs)

### Using Doka stacking pallets as storage units

#### Max. number of units on top of one another

Outdoors (on the site) Floor gradients up to 3%	Indoors Floor gradients up to 1%
2	6
It is not allowed to stack empty multi-trip boxes or pallets on top of one another!	



#### NOTICE

- Stacked multi-trip boxes or pallets must have the heaviest boxes at the bottom and the lightest at the top!
- Castor wheels or bolt-on castor sets must not be fitted to the bottom multi-trip packaging in the stack.
- Secure multi-trip packagings with installed castor wheels using the fixing brake when parking.

## Using Doka stacking pallets as transport devices

### Lifting by crane



#### NOTICE

- Multi-trip packaging items must be lifted individually.
- Use suitable lifting chains:
  - e.g. Doka 4-part chain 3.20m
  - Do not exceed the permitted working load limit of the lifting chains.
- Load the items centrally.
- Fasten the load to the stacking pallet (e.g. with strapping tape or lashing strap) so that it cannot slide or tip out.
- Sling angle  $\beta$  max. 30°!

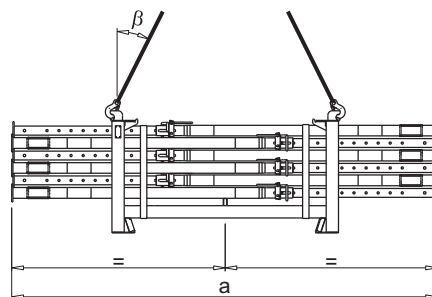

92815-224-01

	a
Doka stacking pallet 1.55x0.85m	max. 4.5 m
Doka stacking pallet 1.20x0.80m	max. 3.0 m

### Repositioning by forklift truck or pallet stacking truck



#### NOTICE

- Load the items centrally.
- Fasten the load to the stacking pallet (e.g. with strapping tape or lashing strap) so that it cannot slide or tip out.

## Doka accessory box

Storage and transport device for small items.

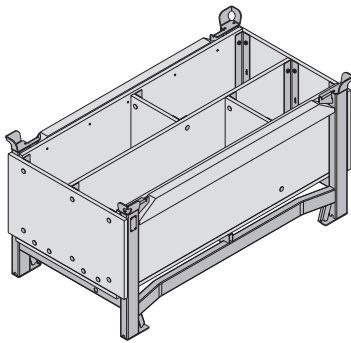

Permitted load-bearing capacity: 1000 kg (2200 lbs)  
 Permitted imposed stacking load: 5530 kg (12190 lbs)

### Doka accessory boxes as storage units

#### Max. number of units on top of one another

Outdoors (on the site) Floor gradients up to 3%	Indoors Floor gradients up to 1%
3	6
It is not allowed to stack empty multi-trip boxes or pallets on top of one another!	



#### NOTICE

- Stacked multi-trip boxes or pallets must have the heaviest boxes at the bottom and the lightest at the top!
- Castor wheels or bolt-on castor sets must not be fitted to the bottom multi-trip packaging in the stack.
- Secure multi-trip packagings with installed castor wheels using the fixing brake when parking.

## Doka accessory box as transport devices

### Lifting by crane



#### NOTICE

- Multi-trip packaging items must be lifted individually.
- Use suitable lifting chains:
  - e.g. Doka 4-part chain 3.20m
  - Do not exceed the permitted working load limit of the lifting chains.
- When lifting units to which Bolt-on castor sets B have been attached, you must also follow the directions in the 'Bolt-on castor set B' User information booklet!
- Sling angle  $\beta$  max. 30°!

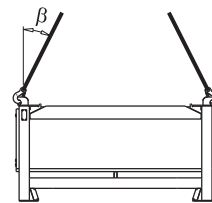

92816-206-01

### Repositioning by forklift truck or pallet stacking truck

The forks can be inserted under either the broadside or the narrowside of the containers.

## Universal castor wheel for transport pallet

The Universal castor wheel for transport pallet turns multi-trip packaging items into fast and manoeuvrable transport devices.

- 4 castor wheels needed per multi-trip packaging item.
- Compatible multi-trip packaging items:
  - Doka stacking pallets (all sizes)
  - Doka multi-trip transport box 1.20x0.80m
  - Doka skeleton transport box 1.70x0.80m
  - DokaXdek panel pallets (all sizes)
  - Superdek beam pallet 1.22x1.10m



Follow the directions in the 'Universal castor wheel for transport pallet' User Information booklet.

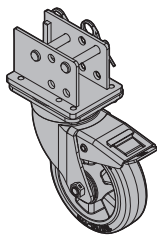

## Bolt-on castor set B

The Bolt-on castor set B turns multi-trip packaging items into fast and manoeuvrable transport devices.

- Suitable for drive-through access openings > 90 cm.
- Compatible multi-trip packaging items:
  - Doka accessory box
  - Doka stacking pallets (all sizes)
  - Protective barrier Z pallets



Follow the directions in the 'Bolt-on castor set B' User Information booklet!

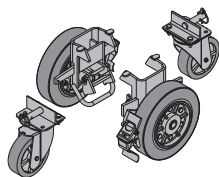

# General

## Areas of use

### Forming self-compacting concrete (SCC)

The **Framax Xlife universal panel SCC** and the **Universal panel SCC 0.45x1.50m** enable the placement of self-compacting concrete (SCC).



#### NOTICE

The connection point for self-compacting concrete (SCC) is not suitable for pouring conventional concrete!



Follow the directions in the 'Forming self-compacting concrete (SCC)' User Information booklet.

#### Used as a stop-end panel Used as a wall panel

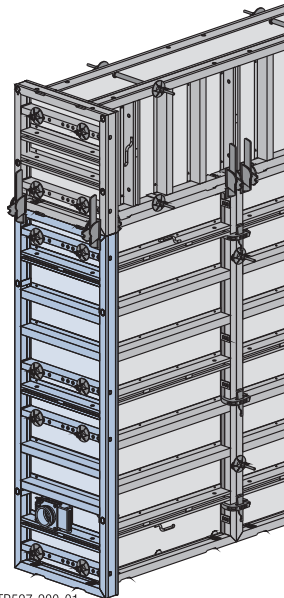

TR527-200-01

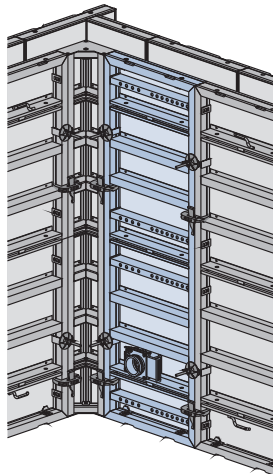

TR527-200-01

### Using as downturned-beam formwork

#### Number of ties, Framax Xlife panel longside horizontal:

Panel length	Downturned beam height	Head anchor (top)	Tie-holder bracket (bottom)
2.70 m	up to 1.35m	2	3
	up to 0.90m	2	2
3.30 m	up to 1.35m	3	3
	up to 0.90m	2	2

#### Framax head anchor:

Permitted tensile force: 10 kN

Permitted compressive force: 10 kN

#### Note:

For directions on installing the Framax head anchor see the section headed 'Framax head anchor'.

#### Framax tie-holder bracket:

Permitted load-bearing capacity: 15 kN

#### Example with 0.90x2.70m panel

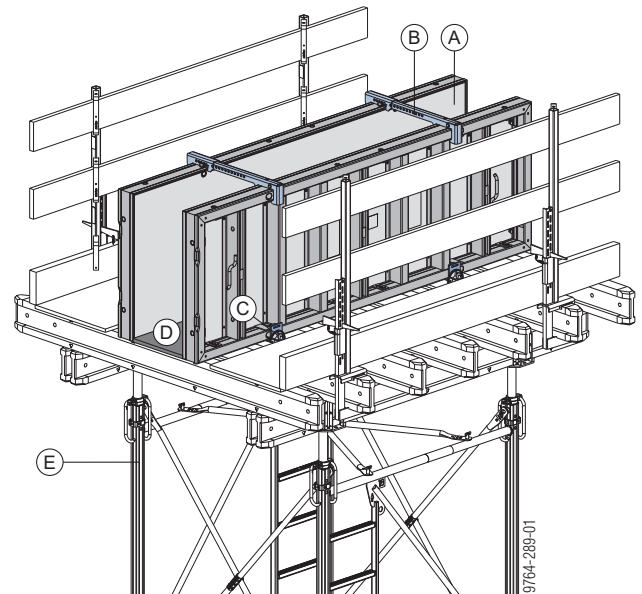

Shown here without ladderways.

A Framax Xlife panel 0.90x2.70m

B Framax head anchor

C Framax tie-holder bracket

D Formwork sheet

E Load-bearing tower (e.g. Staxo 100)

## Framax Xlife in conjunction with . . .

### Framed formwork Alu-Framax Xlife

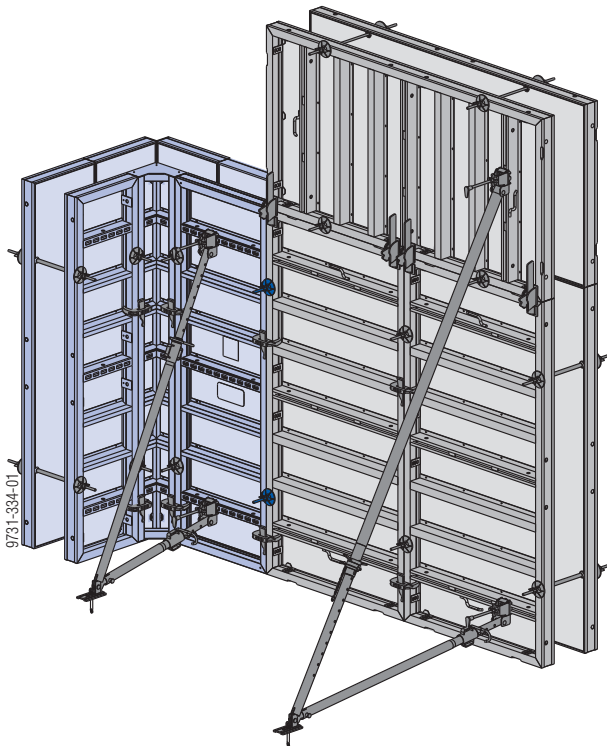

Combining Framax Xlife with Alu-Framax Xlife makes it possible to divide up the work into areas for crane-handled and man-handled forms, facilitating scheduling and the work sequence on the site.

- **Framed formwork Alu-Framax Xlife**
  - for complicated floor plans, or where no crane is available
- **Framed formwork Framax Xlife**
  - for crane-assisted forming of large areas



#### NOTICE

- When you place an Alu-Framax Xlife panel next to a Framax Xlife panel, always place the form tie in the Framax Xlife panel!
- When Framax Xlife and Alu-Framax Xlife panels are used in conjunction with one another, the structural-design data specified in the 'Framed formwork Alu-Framax Xlife' User Information booklet must be followed.

### Climbing formwork MF240

Climbing formwork MF240 proves its versatility on all tall structures. The formwork and climbing scaffold are linked together as a single unit which can be repositioned in one single crane cycle.

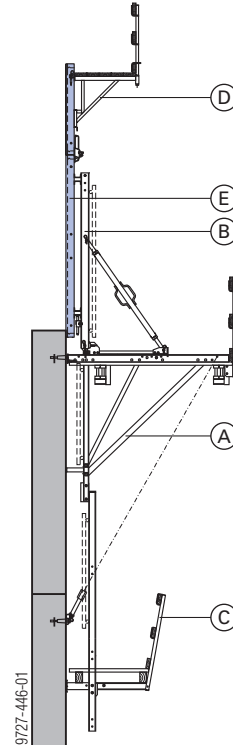

- A Climbing bracket MF240
- B Travelling unit MF
- C Suspended platform MF75 5.00m
- D Framax bracket 90
- E Framax Xlife panel



Follow the directions in the 'Climbing formwork MF240' User Information booklet!

### Framed formwork Framax Xlife plus



#### NOTICE

When combining Framax Xlife with Framax Xlife plus, take the fresh-concrete pressure of the corresponding tie rod system into account (see the 'Framed formwork Framax Xlife plus' User Information booklet).

## Doka automatic climbing formwork

With their modular design concept, these crane-independent automatic climbing formwork systems provide an efficient solution for every type of structure.

The formwork and climbing scaffold are linked together as a single unit which can be lifted and reset hydraulically.



Follow the directions in the relevant User Information booklet.

## Doka folding platforms

The high capacity of these working and safety scaffolds means that the formwork can safely be stood on the folding platforms.

Adding a few standard parts converts a working platform into a climbing formwork unit which can be shifted as a complete form and access-platform in one single operation.

This makes work at great heights faster and more efficient.

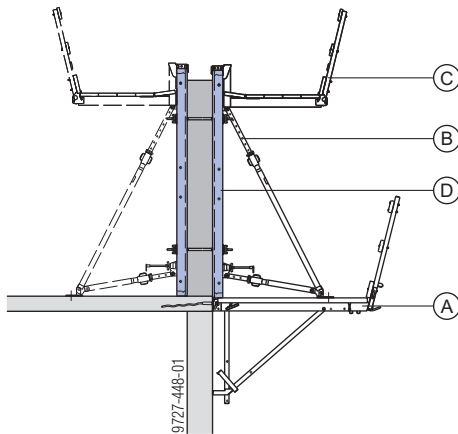

- A Doka folding platform
- B Panel strut
- C Framax pouring platform
- D Framax Xlife panel



Follow the directions in the 'Folding platform K' and 'Climbing formwork K' User Information booklets!

## Doka supporting construction frames

The Doka supporting construction frames also enable the sturdy Framax Xlife panels to be used as single-sided wall formwork.

## Supporting construction frame "Variable"

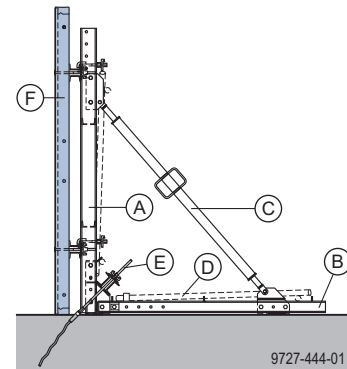

- A Waling WU14 for supporting construction frame
- B Multi-purpose walings WS10 Top50 2.00m
- C Spindle strut 12 3.00m
- D Bracing
- E Tension anchoring
- F Framax Xlife panel



Follow the directions in the 'Supporting construction frame "Variable"' User Information booklet.

## Supporting construction frame "Universal"

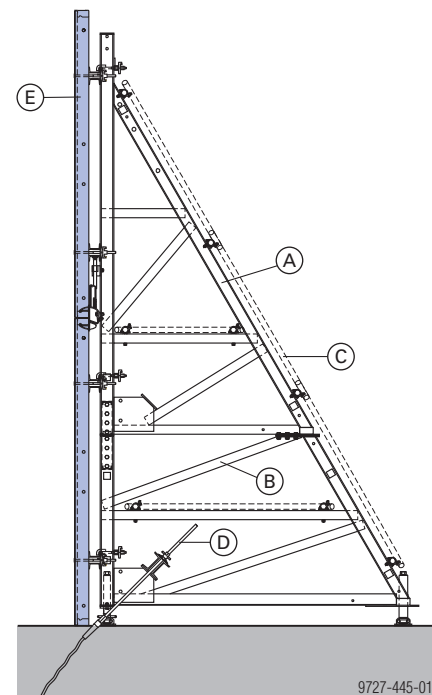

- A Supporting construct. frame Universal F 4.50m
- B Attachable frame F 1.50m
- C Bracing
- D Tension anchoring
- E Framax Xlife panel



Follow the directions in the 'Supporting construction frame "Universal"' User Information booklet.

## Xsafe platform system plus

These pre-assembled, fold-out working platforms with their integral side railings, self-closing man-hole lids and integrable ladders are ready for immediate use and greatly improve workplace safety.

### Easy to use

- pre-assembled, fold-out working platforms
- time and cost-savings as so little assembly work is needed
- system accessories for closure gaps and corner transitions

### Safe working

- high safety, as side and end guards are integrated in the platform
- integrable ladder system

### An economical solution

- its perfect stackability cuts storage and freight costs
- no universal walings needed for bracing the panels in vertically stacked configurations
- simplified planning, from using a single platform concept for all Doka wall systems
- much quicker and more efficient than single brackets

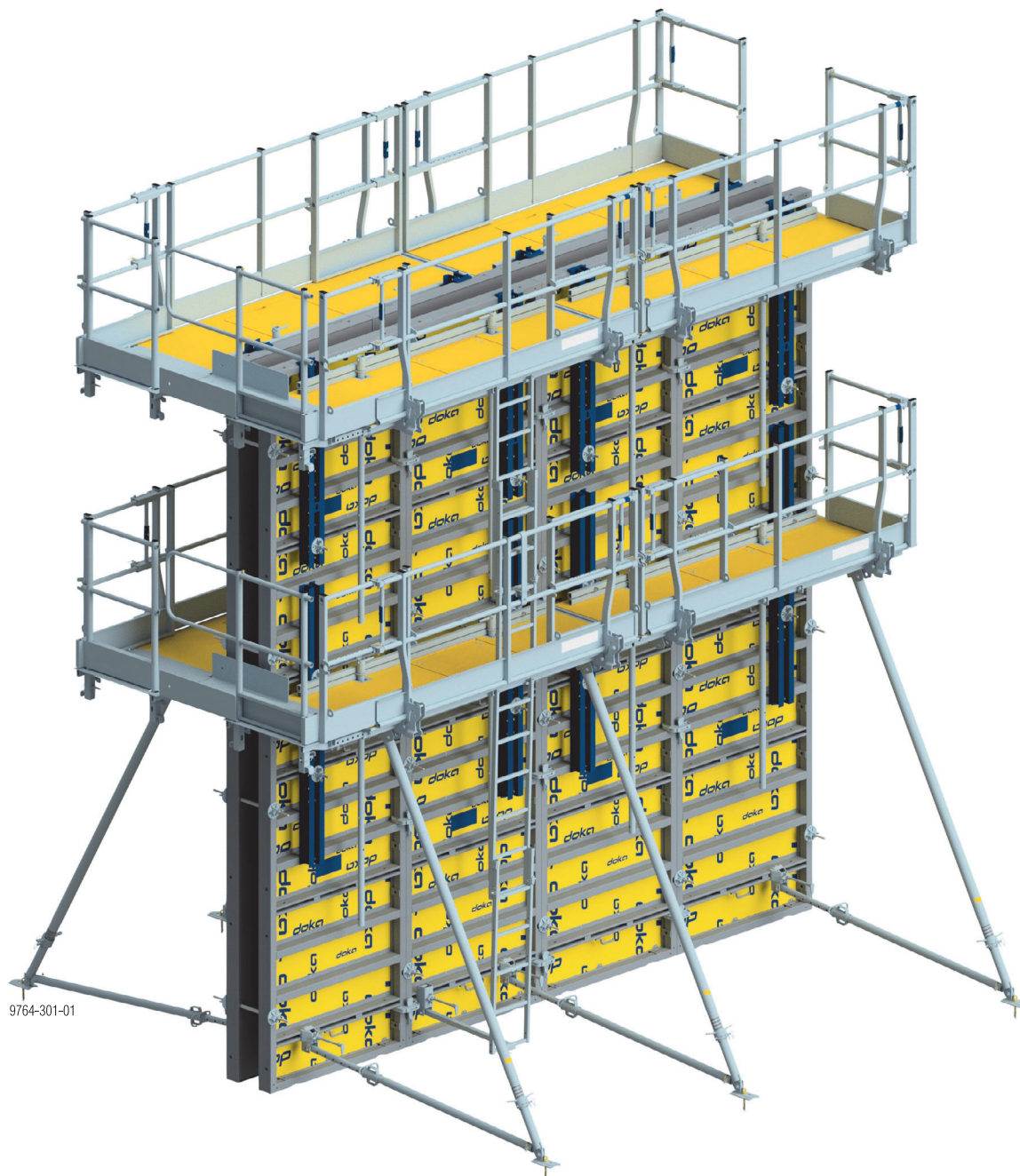

Follow the directions in the 'Xsafe platform system plus' User Information booklet.

## Tie rod system Monotec

- formwork can be tied by just 1 man working from one side only
- no time-consuming fitting of jacket tubes
- exact pre-setting of the desired wall thickness on the Monotec tie
- form-tie nut integrated in the connector component
- enhances your Framax Xlife framed formwork with no need to invest in a new formwork system
- particularly ergonomic where space is tight, as the tie can be installed from the accessible side
- long lifespan, as the tie is operated using a ratchet, minimising wear-and-tear on the equipment
- the Monotec ties are easy to unscrew, so the formwork can be stripped out faster

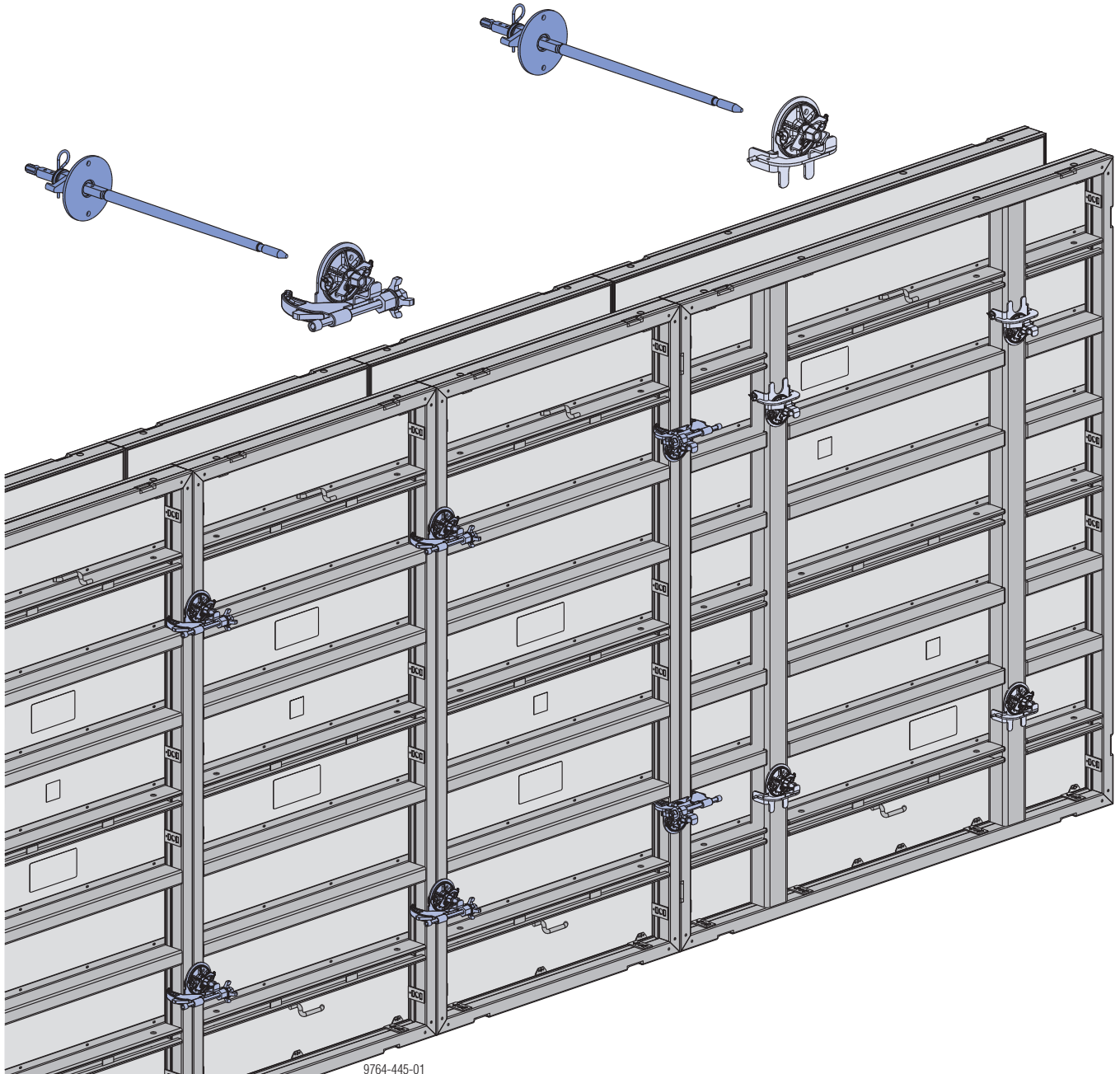

Follow the directions in the 'Tie rod system Monotec' User Information booklet!

## Cleaning and care of your equipment

### Release agents

Doka-Trenn and Doka-OptiX are applied using the Doka release-agent sprayer.

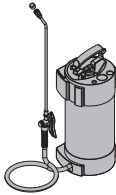

Follow the directions in the 'Doka release-agent sprayer' Operating Instructions and on the containers of release agent.



#### NOTICE

- Before every pour:
  - Apply release agent to the formwork sheet and the end faces **extremely thinly, evenly and in a continuous layer**.
- Make sure there are no drips of release-agent running down the formwork sheet.
- Applying too much release agent will spoil the concrete finish.



To determine the right dosage and to make sure that you are using the agent correctly, test it on less important parts of the structure first.

### Cleaning



#### NOTICE

- Immediately after pouring:
  - Remove any blobs of concrete from the back-face of the formwork, using water (without any added sand).
- Immediately after stripping the formwork:
  - Clean the formwork with a high-pressure washer and a concrete scraper.
- Do not use any chemical cleaning agents!

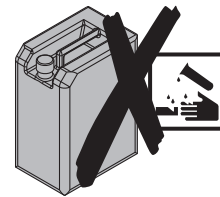

#### Cleaning high formwork:

Provide a service tower at a suitable cleaning location.

- Wheel-around scaffold DF (working heights of up to 3.50 m)
- Ringlock (working heights of up to 12.00 m)

### Cleaning equipment

#### High-pressure spray cleaner

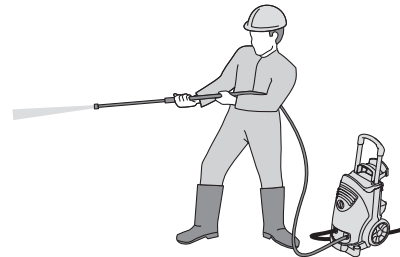

#### NOTICE

- Appliance pressure rating: 200 to max. 300 bar
- Keep the water-jet the correct distance from the formwork, and move it at the right speed:
  - The higher the pressure, the further away from the formwork you must keep the jet and the faster you must move it across the surface.
- Do not aim the jet at one place for too long.
- Make only moderate use of the jet around the silicone sealing strip:
  - If the pressure is too high, this will damage the silicone sealing strip.
  - Do not aim the jet at one place for too long.

### Concrete scraper

For removing any concrete remnants, we recommend using a **Double scraper Xlife** and a spatula.

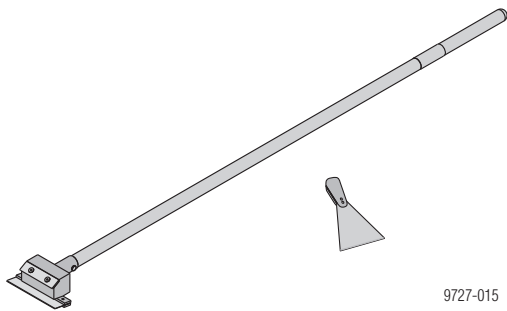

#### Functional description:

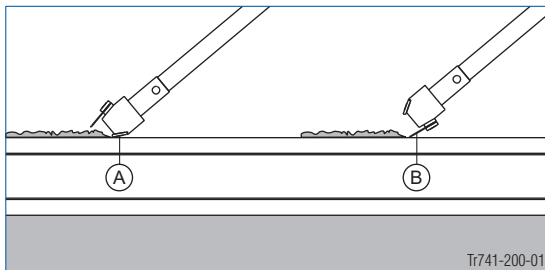
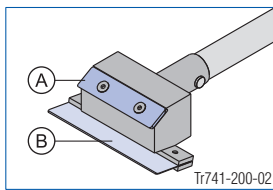

- A Blade for dealing with heavy soiling
- B Blade for dealing with slight soiling



#### NOTICE

Do not use pointed or sharp objects, wire brushes, abrasive disks or cup brushes.

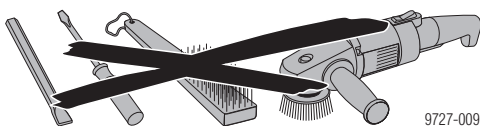

### Care

- No hammer-blows to the frame profiles

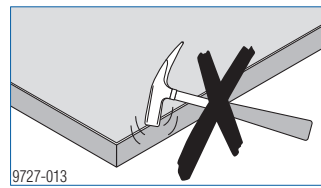

- Do not use nails on the formwork that are longer than 60 mm

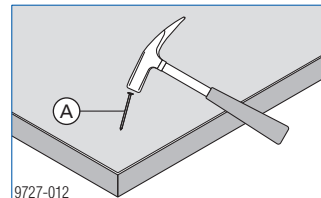

A max. l=60 mm

- Never push over panels or allow them to fall

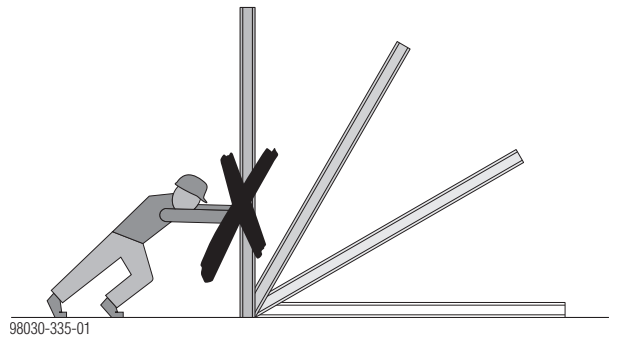

- Only stack panel gangs on top of one another with timber battens (A) between each layer.

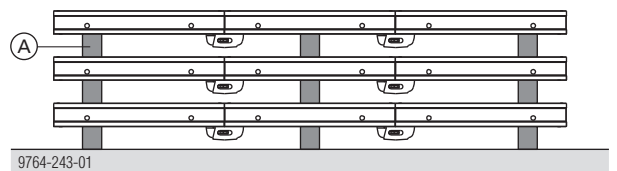

This prevents the formwork sheets from being damaged by the connector components.

## Fall protection on the structure

### Xsafe edge protection XP

- Attached with screw-on shoe, railing clamp, hand-rail-post shoe or Step bracket XP
- Protective grating XP, guardrail boards or scaffold tubes can be used as the safety barrier

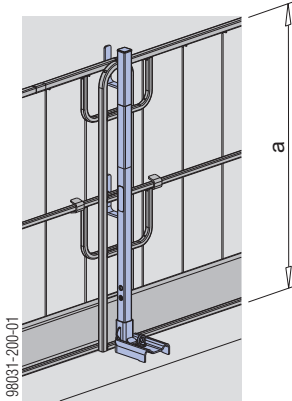

a ... > 1.00 m



Follow the directions in the 'Xsafe edge protection XP' User Information booklet.

### Handrail clamp S

- Attached with integral clamp
- Guard-rail boards or scaffold tubes can be used as the safety barrier

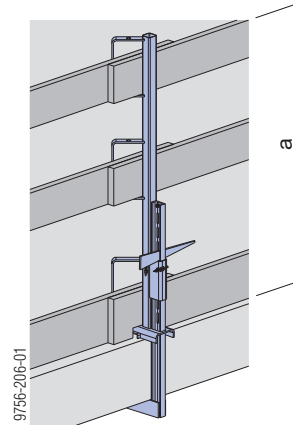

a ... > 1.00 m



Follow the directions in the "Handrail clamp S" User information!

### Xsafe edge protection Z

- Attachment by integral screw-on shoe
- Protective barrier Z can be used as the safety barrier

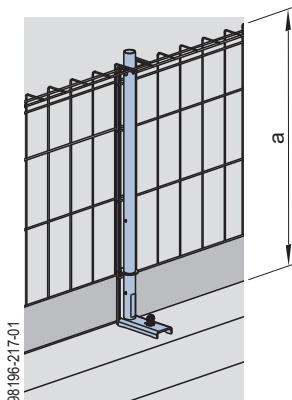

a ... > 1.17 m



Follow the directions in the 'Xsafe edge protection Z' User Information booklet.

### Handrail post 1.10m

- Fixed in a Screw sleeve 20.0 or Attachable sleeve 24mm
- Guard-rail boards or scaffold tubes can be used as the safety barrier

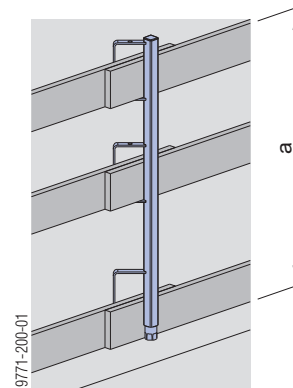

a ... > 1.00 m





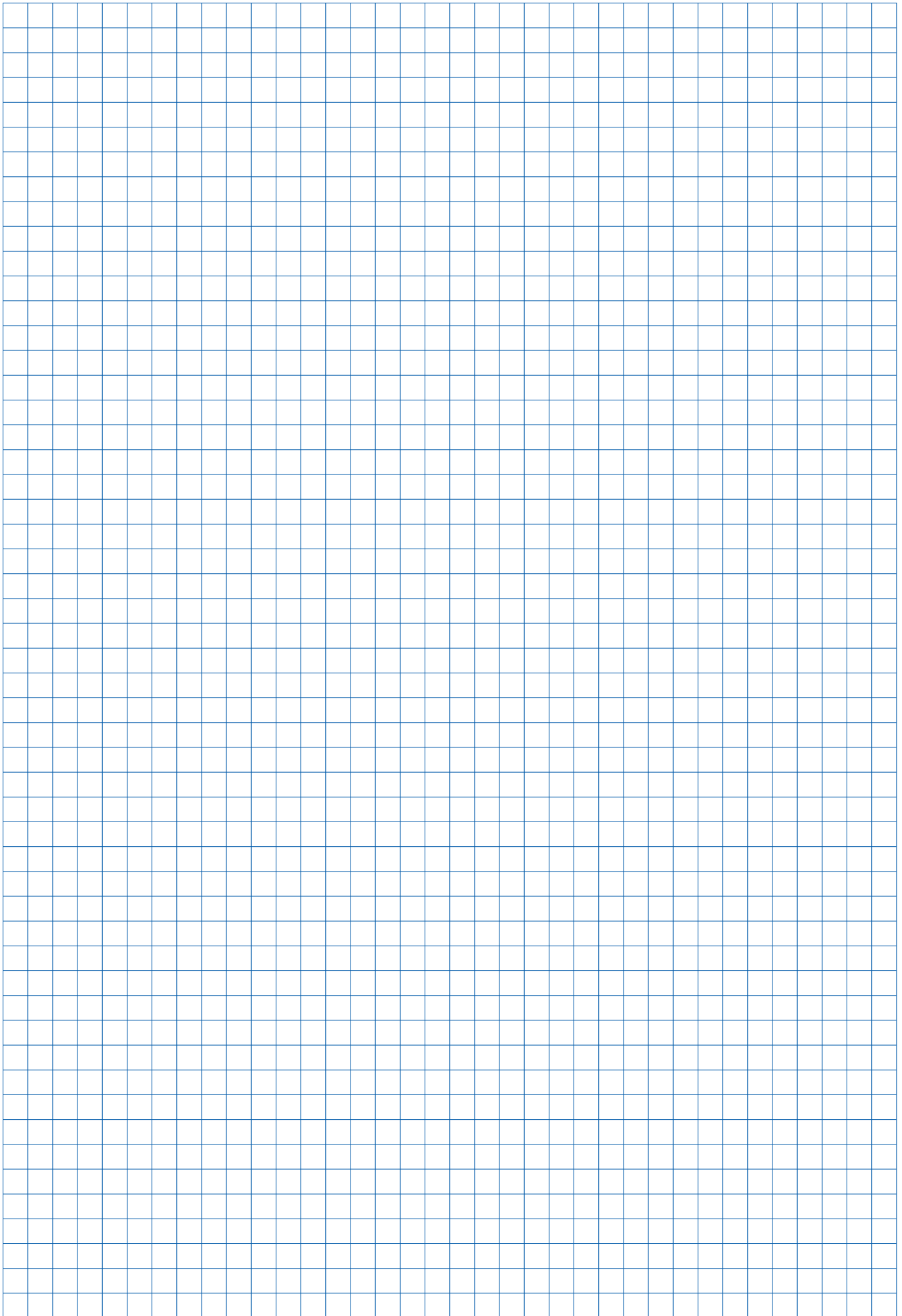

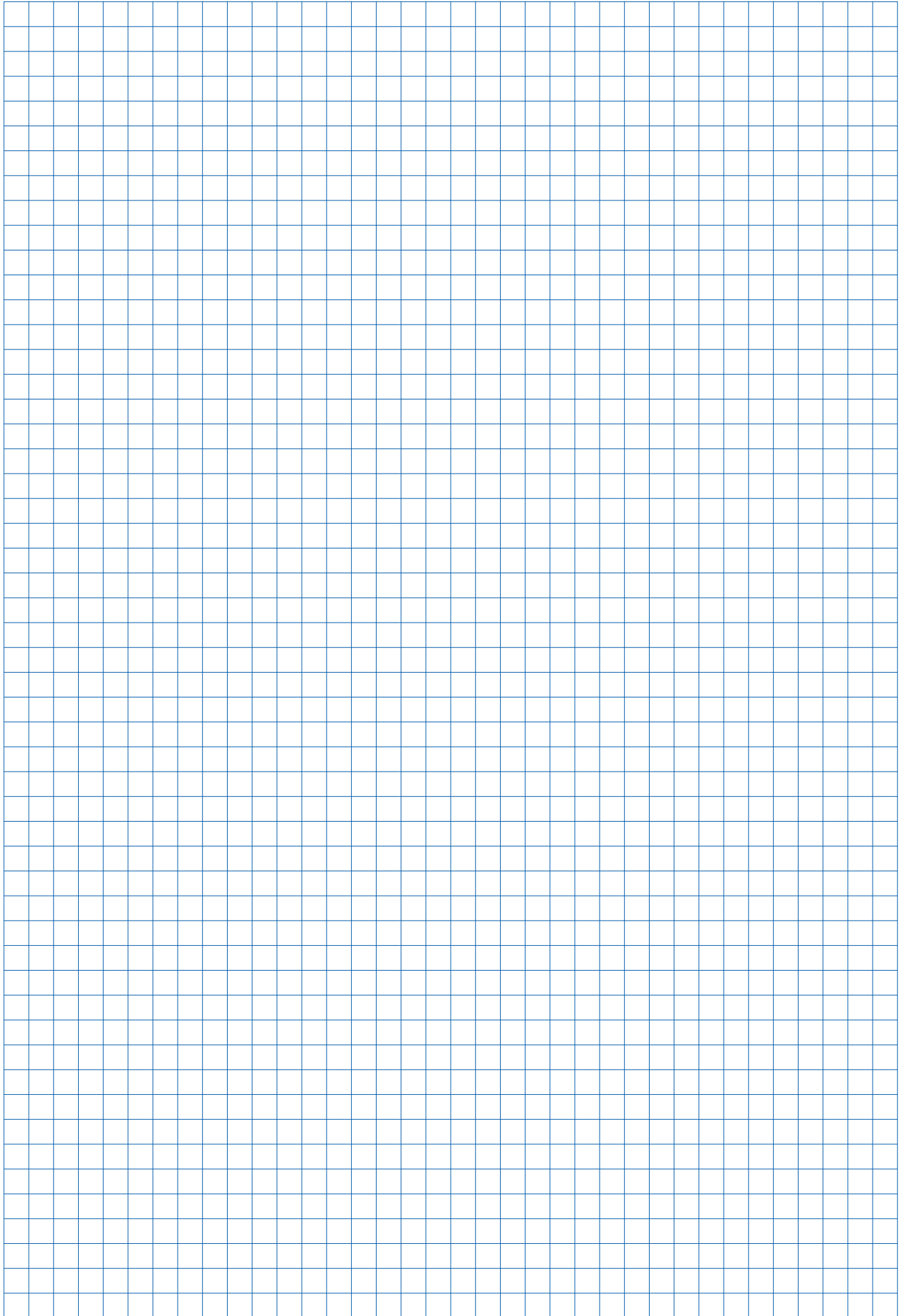



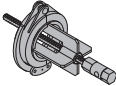

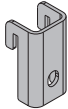
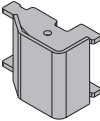
Follow the directions in the 'Handrail post 1.10m' User Information!











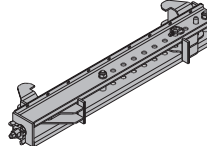

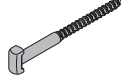
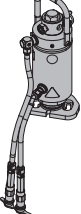
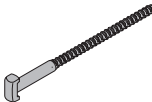

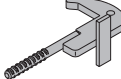
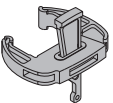
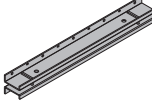
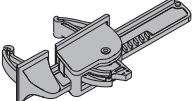
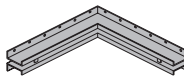

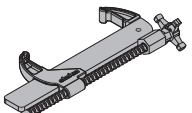

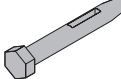

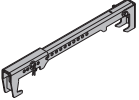
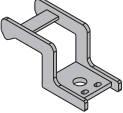
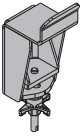
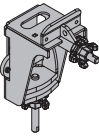
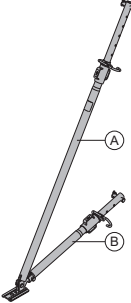

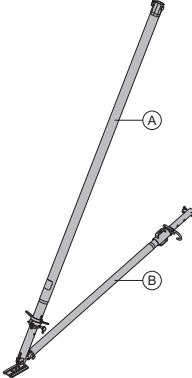
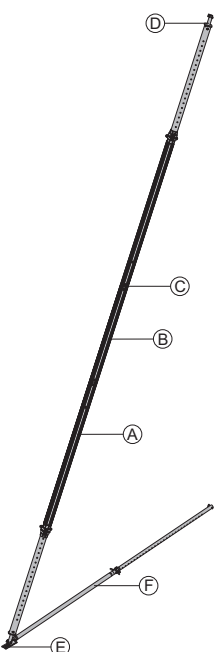
	[kg]	Article N°
<b>Framax hose to panel coupler SCC</b> Framax-Spindelanschluss SCC  Galvanised Length: 48 cm Diameter: 27 cm	10.0	588121000
<b>Panel closure tool D125 SCC</b> Sperrschieber D125 SCC  Galvanised Length: 18 cm Width: 33 cm Height: 27 cm	18.0	588127000
<b>Frami tie-adapter for stripping corner I</b> Frami-Ankeradapter für Ausschalecke I  Galvanised Height: 11 cm	0.47	588492000
<b>Frami profile adapter for stripping corner I</b> Frami-Profiladapter für Ausschalecke I  Galvanised Height: 8 cm	0.6	588491000
<b>Framax Xlife inside corner 3.30m</b> <b>Framax Xlife inside corner 2.70m</b> <b>Framax Xlife inside corner 1.35m</b> Framax Xlife-Innenecke  Galvanised, powder-coated	117.9 97.0 51.2	588229500 588130500 588132500
<b>Framax outside corner 2.70m</b> <b>Framax outside corner 1.35m</b> <b>Framax outside corner 3.30m</b> Framax-Außenecke  Galvanised	47.0 23.5 58.0	588126000 588128000 588227000
<b>Framax hinged inside corner I galv. 2.70m</b> <b>Framax hinged inside corner I galv. 1.35m</b> <b>Framax hinged inside corner I galv. 3.30m</b> Framax-Scharnierecke I  Galvanised, powder-coated	105.8 57.2 129.2	588136500 588137500 588610500

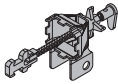
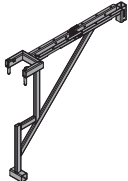
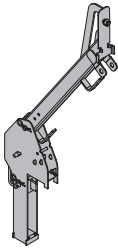
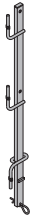
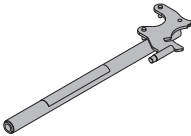
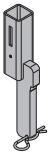



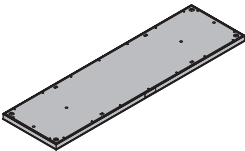

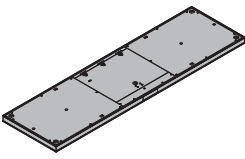
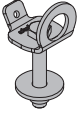
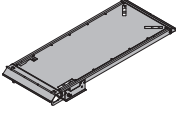
	[kg]	Article N°
<b>Framax hinged inside corner I 2.70m</b> <b>Framax hinged inside corner I 1.35m</b> <b>Framax hinged inside corner I 3.30m</b> Framax-Scharnierecke I  Powder-coated blue	102.3 55.4 125.5	588136000 588137000 588610000
<b>Framax hinged outside corner A galv. 3.30m</b> <b>Framax hinged outside corner A galv. 2.70m</b> <b>Framax hinged outside corner A galv. 1.35m</b> Framax-Scharnierecke A verzinkt  Galvanised, powder-coated	64.0 52.8 27.5	588975000 588942000 588943000
<b>Framax hinged outside corner A 2.70m</b> <b>Framax hinged outside corner A 1.35m</b> Framax-Scharnierecke A  Powder-coated blue	52.8 27.4	588134000 588135000
<b>Framax Xlife pilaster panel 1.35m left</b> <b>Framax Xlife pilaster panel 1.35m right</b> <b>Framax Xlife pilaster panel 3.30m left</b> <b>Framax Xlife pilaster panel 3.30m right</b> Framax Xlife-Stützenvorlageelement  Galvanised	97.7 97.7 234.5 233.5	588973000 588974000 588971000 588972000
<b>Framax stripping corner I 2.70m</b> <b>Framax stripping corner I 1.35m</b> <b>Framax stripping corner I 3.30m</b> Framax-Ausschalecke I  Galvanised, powder-coated	171.0 90.0 209.9	588675000 588614000 588676000



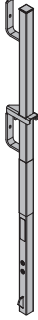
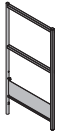
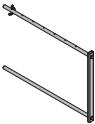

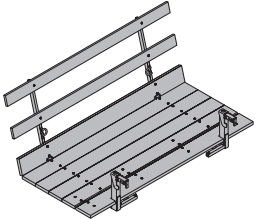
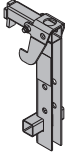
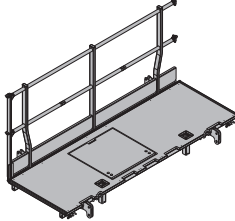
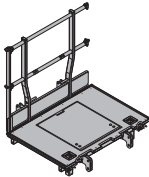
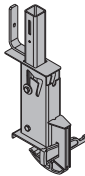
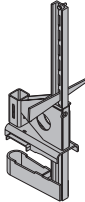
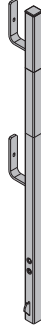

	[kg]	Article N°		[kg]	Article N°	
<b>Framax stripping spindle I</b> Framax-Ausschalspindel I  Galvanised Height: 25 cm	3.2	588618000		<b>Framax stop-end waler tie 15-45cm</b> <b>Framax stop-end waler tie 15-75cm</b> Framax-Stirnabschalzwinge  Galvanised	15.0 20.6	588940000 588941000
<b>Framax stripping spindle I with ratchet</b> Framax-Ausschalspindel I mit Ratsche  Galvanised Height: 24.8 cm	5.5	588653000		<b>Framax universal fixing bolt 10-16cm</b> Framax-Universalverbinder 10-16cm  Galvanised Length: 26 cm	0.6	588158000
<b>Framax stripping cylinder I NG2</b> Framax-Ausschalzylinder I NG2  Painted yellow Width: 16 cm Height: 45.2 cm Follow the directions in the "Operating Instructions"!	30.0	588980500	CE	<b>Framax universal fixing bolt 10-25cm</b> Framax-Universalverbinder 10-25cm  Galvanised Length: 36 cm	0.69	583002000
<b>Framax stripping cylinder I</b> Framax-Ausschalzylinder I  Painted yellow Width: 16 cm Height: 45.2 cm Follow the directions in the "Operating Instructions"!	29.0	588980000	CE	<b>Framax stop-end tie</b> Framax-Stiranker  Galvanised Length: 29 cm	1.5	588143000
<b>Framax quick acting clamp RU</b> Framax-Schnellspanner RU  Galvanised Length: 20 cm	3.1	588153400		<b>Framax universal waling 0.60m</b> <b>Framax universal waling 0.90m</b> <b>Framax universal waling 1.50m</b> Framax-Klemmschiene  Painted blue	6.6 10.6 16.8	588689000 588150000 588148000
<b>Framax multi function clamp</b> Framax-Uni-Spanner  Galvanised Length: 40 cm	5.8	588169000		<b>Framax universal corner waling</b> Framax-Eckklemmschiene  Painted blue Length: 60 cm Width: 60 cm	12.8	588151000
<b>Framax aligning clamp</b> Framax-Richtspanner  Galvanised	8.0	589244000		<b>Framax wedge clamp</b> Framax-Spannklemme  Galvanised Length: 21 cm	1.5	588152000
<b>Framax adjustable clamp</b> Framax-Ausgleichsspanner  Galvanised Length: 48 cm	5.3	588168000		<b>Framax tensioning wedge R</b> Framax-Spannkeil R  Galvanised Height: 11 cm	0.2	588155000
				<b>Framax wedge bolt RA 7.5</b> Framax-Keilbolzen RA 7,5  Galvanised Length: 15 cm	0.34	588159000

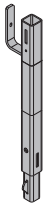

	[kg]	Article N°
<b>Framax head anchor 15-40cm</b> Length: 72 - 81 cm	4.2	588969000
<b>Framax head anchor 15-100cm</b> Length: 131 - 141 cm Framax-Kopfanker	6.1	588970000
 Galvanised, powder-coated		
<b>Framax floor fixing plate</b> Framax-Bodenhalter	0.87	588628000
 Galvanised Length: 17.6 cm Width: 7.7 cm		
<b>Wall-formwork support angle</b> Auflagewinkel Wandschalung	6.6	588967000
 Galvanised Length: 15.8 cm Width: 12 cm Height: 28 cm		
<b>Wall-formwork support angle 2G</b> Auflagewinkel Wandschalung 2G	7.0	589251000
 Galvanised		
<b>Panel strut 340 IB</b> Elementstütze 340 IB consisting of:	24.3	580365000
(A) <b>Plumbing strut 340 IB</b> Galvanised Length: 190.8 - 341.8 cm	16.7	588696000
(B) <b>Adjusting strut 120 IB</b> Galvanised Length: 81.5 - 130.6 cm	7.6	588248500
 Galvanised Delivery condition: folded closed		

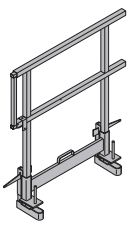
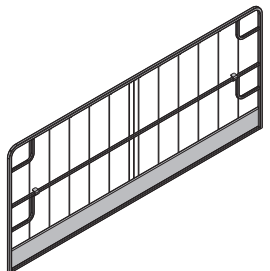
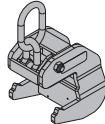
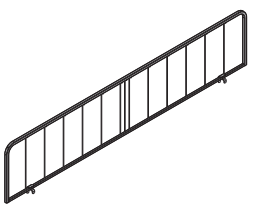
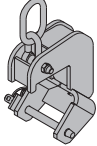
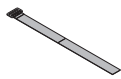
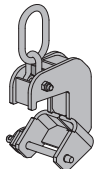



	[kg]	Article N°
<b>Panel strut 540 IB</b> Elementstütze 540 IB consisting of:	41.4	580366000
(A) <b>Plumbing strut 540 IB</b> Galvanised Length: 310.5 - 549.2 cm	30.7	588697000
(B) <b>Adjusting strut 220 IB</b> Galvanised Length: 172.5 - 221.1 cm	10.9	588251500
 Galvanised Delivery condition: folded closed		
<b>Eurex 60 550</b> Eurex 60 550 depending on length, comprising:		
(A) <b>Plumbing strut Eurex 60 550</b> Powder-coated blue Aluminium Length: 343 - 553 cm	42.5	582658000
(B) <b>Extension Eurex 60 2.00m</b> Powder-coated blue Aluminium Length: 250 cm	21.3	582651000
(C) <b>Coupler Eurex 60</b> Aluminium Length: 100 cm Diameter: 12.8 cm	8.6	582652000
(D) <b>Connector Eurex 60 IB</b> Galvanised Length: 15 cm Width: 15 cm Height: 30 cm	4.2	582657500
(E) <b>Plumbing strut shoe Eurex 60 EB</b> Galvanised Length: 31 cm Width: 12 cm Height: 33 cm	8.0	582660500
(F) <b>Adjusting strut 540 Eurex 60 IB</b> Galvanised Length: 303.5 - 542.2 cm	27.8	582659500
 Delivery condition: separate parts		



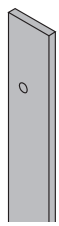
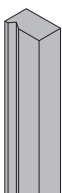
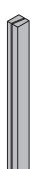





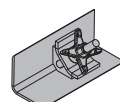

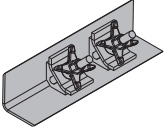

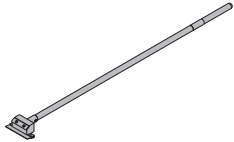
	[kg]	Article N°		[kg]	Article N°
<b>Prop head EB</b> Stützenkopf EB  Galvanised Length: 40.8 cm Width: 11.8 cm Height: 17.6 cm	3.1	588244500	<b>Bracket XBS 90 EP</b> Konsole XBS 90 EP 	10.2	588700000
<b>Framax panel strut connector I</b> Framax-Elementstützenanschluss I Galvanised 	29.0	589250000	<b>Handrail post 1.00m</b> Geländer 1,00m Galvanised Length: 124 cm 	3.8	584335000
<b>Universal dismantling tool</b> Universal-Lösewerkzeug Galvanised Length: 75.5 cm 	3.6	582768000	<b>Bracket adapter XP FRR 50/30</b> Konsolenadapter XP FRR 50/30 Galvanised Height: 32 cm 	2.4	586486000
<b>Doka express anchor 16x125mm</b> Doka-Expressanker 16x125mm Galvanised Length: 18 cm 	0.31	588631000	<b>Framax adapter XBS</b> Framax-Adapter XBS 	5.2	588701000
<b>Doka coil 16mm</b> Doka-Coil 16mm Galvanised Diameter: 1.6 cm 	0.009	588633000	<b>Deck XBS 75/270cm</b> Deck XBS 75/135cm Belag XBS Aluminium 	23.0 8.0	588702000 588710000
<b>Information plate for express anchor</b> Plakette Expressanker  PS Width: 8 cm Height: 7.5 cm	0.1	588630000	<b>Hatch deck XBS 75/270cm</b> Durchstiegsbelag XBS 75/270cm Aluminium 	24.9	588703000
<b>Tie-off set PPE type A</b> Anhängeset PSA Typ A 	0.49	589199500	<b>Infill deck XBS 75cm</b> Ausgleichsbelag XBS 75cm Aluminium 	25.0	588704000
<b>Framax bracket 90 EP</b> Framax-Konsole 90 EP Galvanised Length: 103 cm Height: 84 cm 	9.0	588979000			

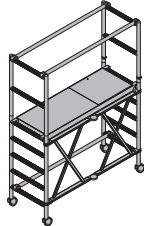

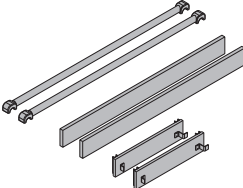
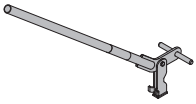
	[kg]	Article N°		[kg]	Article N°
<b>Handrail post XBS 1.40m</b> Geländersteher XBS 1,40m 	4.0	588705000			
<b>Side railing XBS 75cm</b> Seitengeländer XBS 75cm 	10.0	588706000			
<b>Handrail extension XBS</b> Geländerverlängerung XBS 	6.3	588707000			
<b>Scaffold tube connection</b> Gerüstrohranschluss 	0.27	584375000	Galvanised Height: 7 cm		
<b>Scaffold tube 48.3mm 0.50m</b> <b>Scaffold tube 48.3mm 1.00m</b> <b>Scaffold tube 48.3mm 1.50m</b> <b>Scaffold tube 48.3mm 2.00m</b> <b>Scaffold tube 48.3mm 2.50m</b> <b>Scaffold tube 48.3mm 3.00m</b> <b>Scaffold tube 48.3mm 3.50m</b> <b>Scaffold tube 48.3mm 4.00m</b> <b>Scaffold tube 48.3mm 4.50m</b> <b>Scaffold tube 48.3mm 5.00m</b> <b>Scaffold tube 48.3mm 5.50m</b> <b>Scaffold tube 48.3mm 6.00m</b> Gerüstrohr 48,3mm 	1.7 3.6 5.4 7.2 8.4 10.8 12.6 14.4 16.2 18.0 19.8 21.6 3.6	682026000 682014000 682015000 682016000 682017000 682018000 682019000 682021000 682022000 682023000 682024000 682025000 682001000	Galvanised		
<b>Screw-on coupler 48mm 50</b> Anschraubkupplung 48mm 50 	0.8	682002000	Galvanised Width-across: 22 mm		
<b>Framax pouring platform U 1.25/2.70m</b> Framax-Betonierbühne U 1,25/2,70m 	127.5	588377000	Steel parts galvanised Timber parts varnished yellow Delivery condition: folded closed		
<b>Xsafe plus lifting adapter Framax</b> Xsafe plus-Umsetzadapter Framax 	6.6	586436000	Galvanised Height: 51.4 cm		
<b>Xsafe plus platform 2.70m</b> Xsafe plus-Bühne 2,70m 	151.7	586404000	Steel parts galvanised Timber parts varnished yellow Height: 136 cm Delivery condition: folded closed		
<b>Xsafe plus platform 1.35m</b> Xsafe plus-Bühne 1,35m 	95.3	586408000	Steel parts galvanised Timber parts varnished yellow Height: 136 cm Delivery condition: folded closed		
<b>Framax adapter XP</b> Framax-Adapter XP 	8.0	586475000	Galvanised Height: 56 cm		
<b>Railing clamp XP 40cm</b> Geländerzwinge XP 40cm 	7.7	586456000	Galvanised Height: 73 cm		
<b>Handrail post XP 1.20m</b> Geländersteher XP 1,20m 	4.1	586460000	Galvanised Height: 118 cm		
<b>Toeboard holder XP 1.20m</b> Fußwehrhalter XP 1,20m 	0.64	586461000	Galvanised Height: 21 cm		

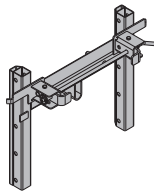
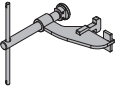

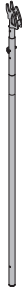
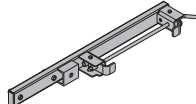

	[kg]	Article N°		[kg]	Article N°	
<b>Handrail post XP 0.60m</b> Geländersteher XP 0,60m  Galvanised Height: 68 cm	5.0	586462000		<b>Handrail post 1.10m</b> Schutzgeländer 1,10m  Galvanised Height: 134 cm	5.5	584384000
<b>Toeboard holder XP 0.60m</b> Fußwehrhalter XP 0,60m  Galvanised Height: 21 cm	0.77	586463000		<b>Side handrail clamping unit T</b> Seitenschutzgeländer T  Galvanised Length: 115 - 175 cm Height: 112 cm	29.1	580488000
<b>Protective grating XP 2.70x1.20m</b> <b>Protective grating XP 2.50x1.20m</b> <b>Protective grating XP 2.00x1.20m</b> <b>Protective grating XP 1.20x1.20m</b> Schutzgitter XP  Galvanised	22.2 20.5 17.4 12.0	586450000 586451000 586452000 586453000		<b>Framax lifting hook</b> Framax-Umsetzbügel  Galvanised Height: 22 cm Follow the directions in the "Operating Instructions"!	10.6	588149000
<b>Protective grating XP 2.70x0.60m</b> <b>Protective grating XP 2.50x0.60m</b> <b>Protective grating XP 2.00x0.60m</b> <b>Protective grating XP 1.20x0.60m</b> Schutzgitter XP  Galvanised	10.1 9.5 8.0 5.0	586466000 586472000 586473000 586491000		<b>Framax lifting hook 20kN</b> Framax-Umsetzbügel 20kN  Galvanised Height: 30 cm Follow the directions in the "Operating Instructions"!	12.8	588526000
<b>Velcro fastener 30x380mm</b> Klettverschluss 30x380mm  Yellow	0.02	586470000		<b>Framax lifting hook 25kN</b> Framax-Umsetzbügel 25kN  Galvanised Height: 30 cm Follow the directions in the "Operating Instructions"!	12.5	588531000
<b>Handrail clamp S</b> Schutzgeländerzwinde S  Galvanised Height: 123 - 171 cm	11.5	580470000		<b>Framax stacking cone</b> Framax-Stapelkonus  Blue Diameter: 2.3 cm	0.01	588234000
				<b>Doka 4-part chain 3.20m</b> Doka-Vierstrangkette 3,20m  Follow the directions in the "Operating Instructions"!	15.0	588620000

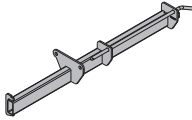

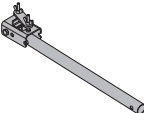
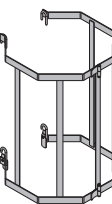
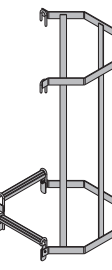

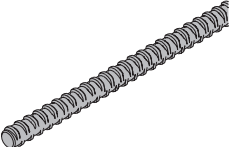
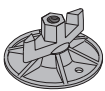

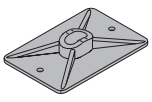

	[kg]	Article N°
<b>Framax transport bolt</b> Framax-Transportbolzen  Follow the directions in the "Operating Instructions"!	1.9	588621000
		CE
<b>Framax transport gear</b> Framax-Transportgehänge  Galvanised Follow the directions in the "Operating Instructions"!	13.3	588232000
		CE
<b>Dokamatic lifting strap 13.00m</b> Dokamatic-Umsetzgurt 13,00m  Green Follow the directions in the "Operating Instructions"!	10.5	586231000
		CE
<b>Framax fitting timber 2x12cm 2.70m</b> Framax fitting timber 3x12cm 2.70m Framax fitting timber 5x12cm 2.70m Framax fitting timber 10x12cm 2.70m Framax fitting timber 2x12cm 3.30m Framax fitting timber 3x12cm 3.30m Framax fitting timber 5x12cm 3.30m Framax fitting timber 10x12cm 3.30m Framax-Passholz  Varnished yellow	3.1 4.7 7.8 15.5 3.8 5.7 9.5 19.0	176020000 176022000 176024000 176026000 176021000 176023000 176025000 176027000
<b>Framax moulded timber 27mm 2.70m</b> Framax moulded timber 21mm 2.70m Framax moulded timber 18mm 2.70m Framax moulded timber 27mm 3.30m Framax moulded timber 21mm 3.30m Framax moulded timber 18mm 3.30m Framax-Profilholz  Varnished yellow	7.6 8.0 8.4 9.3 9.8 10.2	176012000 176010000 176119000 176013000 176011000 176120000
<b>Framax formwork stripping timb. 10x12cm 2.85m</b> Framax formwork stripping timb. 10x12cm 3.45m Framax-Ausschalholz  Varnished yellow	16.4 19.9	176008000 176014000

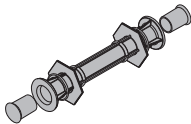
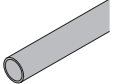
	[kg]	Article N°
<b>Framax steel closure plate 5cm 3.30m</b> Framax-Stahlausgleich 5cm 3,30m  Powder-coated blue	17.2	588274000
<b>Framax aluminium closure 10cm 3.30m</b> Framax aluminium closure 10cm 2.70m Framax aluminium closure 10cm 1.35m Framax aluminium closure 5cm 3.30m Framax aluminium closure 5cm 2.70m Framax aluminium closure 5cm 1.35m Framax-Alu-Ausgleich  Powder-coated	12.9 11.0 5.7 10.5 8.5 4.4	589229000 589227000 589225000 589228000 589226000 589224000
<b>Connecting timber</b> Anklemmholz  Varnished yellow Width: 10 cm	0.7	176030000
<b>Framax triangular ledge 2.70m</b> Framax-Dreikantleiste 2,70m 	0.38	588170000
<b>Framax frontal triangular ledge 2.70m</b> Framax frontal triangular ledge 3.30m Framax-Stindreikantleiste  Grey	1.7 2.0	588129000 588949000
<b>Box-out clamp type 1 .....cm</b> Ausparungsklemme Typ 1 .....cm  Painted blue Length: 10 cm Width: 10 cm	17.4	580066000

	[kg]	Article N°		[kg]	Article N°
<b>Box-out clamp type 2 .....cm</b> Aussparungsklemme Typ 2 .....cm  Painted blue Length: 10 cm Width: 10 cm	17.4	580067000	<b>Alu beam fork H20</b> Alu-Trägergabel H20  Aluminium Powder-coated yellow Length: 176 cm	2.4	586182000
<b>Framax tie-holder bracket</b> Framax-Ankerhaltewinkel  Painted blue Width: 9 cm Height: 13 cm	1.4	588188000	<b>Double scraper Xlife 100/150mm 1.40m</b> Doppelschaber Xlife 100/150mm 1,40m 	2.8	588674000
<b>Universal plug R20/25</b> Kombi-Ankerstopfen R20/25  Blue Diameter: 3 cm	0.003	588180000	<b>Wheel-around scaffold DF</b> Mobilgerüst DF  Aluminium Length: 185 cm Width: 80 cm Height: 255 cm Delivery condition: separate parts	44.0	586157000
<b>Framax plug R24.5</b> Framax-Abdeckstopfen R24,5  Yellow Diameter: 2 cm	0.003	588181000	<b>Wheel-around scaffold DF accessory set</b> Zubehörset Mobilgerüst DF  Aluminium Timber parts varnished yellow Length: 189 cm	13.3	586164000
<b>Framax positioning lever</b> Framax-Einrichthebel  Galvanised Length: 135 cm	5.6	589245000	<b>Ladder system XS</b>		
<b>Framax stripping tool</b> Framax-Ausschalwerkzeug  Galvanised Length: 110 cm	5.5	589235000	<b>Connector XS wall formwork</b> Anschluss XS Wandschalung  Galvanised Width: 89 cm Height: 63 cm	20.8	588662000
<b>Framax stripping aid</b> Framax-Ausschalhilfe  Galvanised	3.2	589246000	<b>Fixing clamp XS Framax</b> Befestigungsklemme XS Framax  Galvanised Length: 20 cm Width-across: 27 mm	1.5	588677000
<b>Framax telescopic assembling tool</b> Framax-Teleskop-Montagestange  Aluminium Length: 230 - 400 cm	3.8	588651000	<b>Connector XS Framax/Alu-Framax</b> Anschluss XS Framax/Alu-Framax  Galvanised Length: 115 cm	11.2	588639000
<b>Framax assembling tool</b> Framax-Montagestange  Galvanised Length: 193 cm	4.2	588678000			

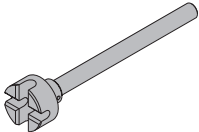
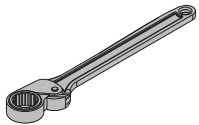
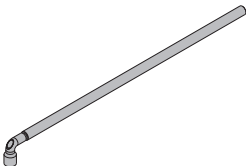
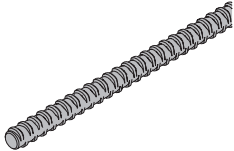
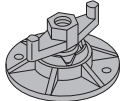
	[kg]	Article N°
<b>Connector XS column formwork platform</b> Anschluss XS Stützenbühne  Galvanised Length: 123 cm	10.0	588637000
<b>System ladder XS 4.40m</b> System-Leiter XS 4,40m  Galvanised	33.2	588640000
<b>Ladder extension XS 2.30m</b> Leiternverlängerung XS 2,30m  Galvanised	19.1	588641000
<b>Securing barrier XS</b> Sicherungsschranke XS  Galvanised Length: 80 cm	4.9	588669000
<b>Ladder cage XS 1.00m</b> Ladder cage XS 0.25m Rückenschutz XS  Galvanised	16.5	588643000
<b>Ladder cage exit XS</b> Rückenschutz-Ausstieg XS  Galvanised Height: 132 cm	17.0	588666000

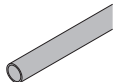
	[kg]	Article N°
<b>Tie rod system 15.0</b> Tie rod 15.0mm galvanised 0.50m Tie rod 15.0mm galvanised 0.75m Tie rod 15.0mm galvanised 1.00m Tie rod 15.0mm galvanised 1.25m Tie rod 15.0mm galvanised 1.50m Tie rod 15.0mm galvanised 1.75m Tie rod 15.0mm galvanised 2.00m Tie rod 15.0mm galvanised 2.50m Tie rod 15.0mm galvanised .....m Tie rod 15.0mm non-treated 0.50m Tie rod 15.0mm non-treated 0.75m Tie rod 15.0mm non-treated 1.00m Tie rod 15.0mm non-treated 1.25m Tie rod 15.0mm non-treated 1.50m Tie rod 15.0mm non-treated 1.75m Tie rod 15.0mm non-treated 2.00m Tie rod 15.0mm non-treated 2.50m Tie rod 15.0mm non-treated 3.00m Tie rod 15.0mm non-treated 3.50m Tie rod 15.0mm non-treated 4.00m Tie rod 15.0mm non-treated 5.00m Tie rod 15.0mm non-treated 6.00m Tie rod 15.0mm non-treated .....m Ankerstab 15,0mm 	0.72 1.1 1.4 1.8 2.2 2.5 2.9 3.6 1.4 0.73 1.1 1.4 1.8 2.1 2.5 2.9 3.6 4.3 5.0 5.7 7.2 8.6 1.4	581821000 581822000 581823000 581826000 581827000 581828000 581829000 581852000 581824000 581870000 581871000 581874000 581886000 581876000 581887000 581875000 581877000 581878000 581888000 581879000 581880000 581881000 581873000
<b>Super plate 15.0</b> Superplatte 15,0  Galvanised Height: 6 cm Diameter: 12 cm Width-across: 27 mm	0.98	581966000
<b>Wing nut 15.0</b> Flügelmutter 15,0  Galvanised Length: 10 cm Height: 5 cm Width-across: 27 mm	0.31	581961000
<b>Hexagon nut 15.0</b> Sechskantmutter 15,0  Galvanised Length: 5 cm Width-across: 30 mm	0.23	581964000
<b>Framax pressure plate 6/15</b> Framax-Druckplatte 6/15  Galvanised	0.8	588183000
<b>Star grip nut 15.0 G</b> Sternmutter 15,0 G  Galvanised Width: 10 cm Height: 5 cm Width-across: 27 mm	0.43	587544000
<b>Angle anchor plate 12/18</b> Winkelplatte 12/18  Galvanised	1.5	581934000

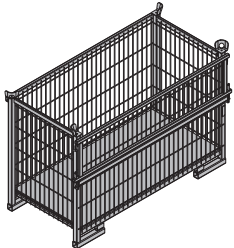
		[kg]	Article N°			[kg]	Article N°
Distance piece 20cm Distance piece 25cm Distance piece 30cm Distanzhalter	PE Grey Blue	0.04 0.05 0.06	581907000 581908000 581909000				
Plastic tube 22mm 2.50m Kunststoffrohr 22mm 2,50m	PVC Grey Diameter: 2.6 cm	0.45	581951000				
Universal cone 22/10mm Universal-Konus 22/10mm	Grey Diameter: 4 cm	0.005	581995000				
Plug 22mm Verschlussstopfen 22mm	PE Grey	0.003	581953000				
Protective cap 15.0/20.0 Schutzkappe 15,0/20,0	Yellow Length: 6 cm Diameter: 6.7 cm	0.03	581858000				
Tie-rod wrench 15.0/20.0 Ankerstabschlüssel 15,0/20,0	Galvanised	1.8	580594000				
Friction type ratchet SW27 Freilaufnarre SW27	Manganese-phosphated Length: 30 cm	0.49	581855000				
Box spanner 27 0.65m Steckschlüssel 27 0,65m	Galvanised	1.9	581854000				
<b>Tie rod system 20.0</b>							
Tie rod 20.0mm galvanised 0.50m		1.3	581411000				
Tie rod 20.0mm galvanised 0.75m		1.9	581417000				
Tie rod 20.0mm galvanised 1.00m		2.5	581412000				
Tie rod 20.0mm galvanised 1.25m		3.2	581418000				
Tie rod 20.0mm galvanised 1.50m		3.8	581413000				
Tie rod 20.0mm galvanised 2.00m		5.0	581414000				
Tie rod 20.0mm galvanised 2.50m		6.3	581430000				
Tie rod 20.0mm galvanised .....m		2.5	581410000				
Tie rod 20.0mm non-treated 0.50m		1.3	581405000				
Tie rod 20.0mm non-treated 0.75m		1.9	581416000				
Tie rod 20.0mm non-treated 1.00m		2.5	581406000				
Tie rod 20.0mm non-treated 1.50m		3.8	581407000				
Tie rod 20.0mm non-treated 2.00m		5.0	581408000				
Tie rod 20.0mm non-treated .....m		2.5	581403000				
Ankerstab 20,0mm							DIN 18216
Super plate 20.0 B Superplatte 20,0 B	Galvanised Height: 7 cm Diameter: 14 cm Width-across: 34 mm	2.0	581424000				DIN 18216
Hexagon nut 20.0 Sechskantmutter 20,0	Galvanised Length: 7 cm Width-across: 41 mm	0.4	581420000				DIN 18216
Plastic tube 26mm 2.00m Kunststoffrohr 26mm 2,00m	PVC Grey Diameter: 3.1 cm	0.59	581463000				
Universal cone 26/10mm Universal-Konus 26/10mm	Grey Diameter: 5 cm	0.008	581464000				
Plug 26mm Verschlussstopfen 26mm	PE Grey	0.006	581465000				
<b>Multi-trip packaging</b>							
Doka skeleton transport box 1.70x0.80m Doka-Gitterbox 1,70x0,80m	Galvanised Height: 113 cm	87.0	583012000				

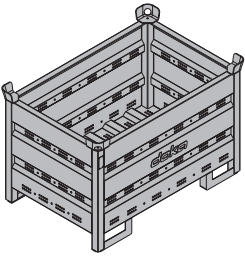
	[kg]	Article N°
<b>Doka multi-trip transport box 1.20x0.80m</b> Doka-Mehrwegcontainer 1,20x0,80m Galvanised Height: 78 cm 	70.0	583011000

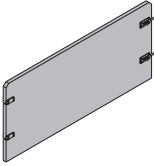
<b>Multi-trip transport box partition 0.80m</b> Steel parts galvanised Timber parts varnished yellow 	3.7	583018000
<b>Multi-trip transport box partition 1.20m</b> Mehrwegcontainer Unterteilung Steel parts galvanised Timber parts varnished yellow	5.5	583017000

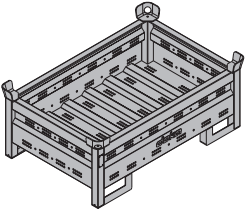
<b>Doka multi-trip transport box 1.20x0.80x0.41m</b> Doka-Mehrwegcontainer 1,20x0,80x0,41m Galvanised 	42.5	583009000
--	------	-----------

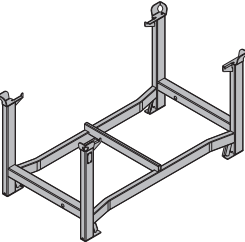
<b>Doka stacking pallet 1.55x0.85m</b> Doka-Stapelpalette 1,55x0,85m Galvanised Height: 77 cm 	41.0	586151000
--	------	-----------

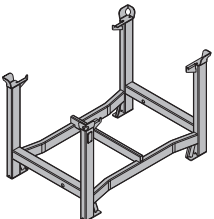
<b>Doka stacking pallet 1.20x0.80m</b> Doka-Stapelpalette 1,20x0,80m Galvanised Height: 77 cm 	38.0	583016000
---	------	-----------

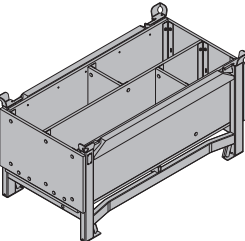
<b>Doka accessory box</b> Doka-Kleinteilebox Timber parts varnished yellow Steel parts galvanised Length: 154 cm Width: 83 cm Height: 77 cm 	106.4	583010000
---	-------	-----------

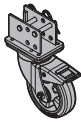
	[kg]	Article N°
<b>Universal castor wheel for transport pallet</b> Universal-Lenkrolle Transportgebände Galvanised Height: 28.8 cm 	6.0	584043000

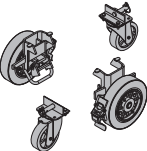
<b>Bolt-on castor set B</b> Anklemm-Radsatz B Painted blue 	33.6	586168000
---	------	-----------





Formwork & Scaffolding.  
**We make it work.**

---



[www.doka.com/framax-xlife](http://www.doka.com/framax-xlife)