

National Technical Approval

Approval number: Z-12.5-96

Applicant: Stahlwerk Annahütte
Max Aicher GmbH & Co.KG
83404 Ainring

Generic type of construction product: Steel bar anchor St 900/1100 with thread ribs AWM
1100
Nominal diameter 15.0 and 20.0 mm

Validity
from: 1 October 2015
to: 1. October 2020

The aforementioned construction product is herewith granted national technical approval.
This National Technical Approval contains seven pages and two annexes.
The aforementioned construction product was first granted a National Technical Approval on 13 September 2005.

Translation of the original German version of these Nation Technical Approval is not proved by Deutsches Institut für Bautechnik (DIBt)

I. GENERAL PROVISIONS

1. This National Technical Approval attests to the usability and applicability of the aforementioned construction product in accordance with German federal state building regulations.
2. Provided the national technical approval specifies requirements regarding the specialized professional expertise and experience of the personnel responsible for the production of construction products and application of construction methods in accordance with federal state regulations according to § 17 article 5 model building regulation, it is noted that this expertise and experience may also be proven by equivalent verifications by other Member States of the European Union. This also applies, where required, to equivalent verifications submitted within the scope of the European Economic Area Treaty or other bilateral agreements
3. This National Technical Approval does not replace the permits, licences and certificates required by German law for the execution of construction projects.
4. This National Technical Approval is granted without prejudice to third party rights, in particular private property rights.
5. Irrespective of further provisions laid down in the “Specific Provisions” section, the manufacturer and supplier of the aforementioned construction product shall provide users and appliers of the construction product with copies of the National Technical Approval and inform them that the National Technical Approval must be available at the construction site. On request, copies of the National technical Approval shall be submitted to all authorities involved.
6. Reproduction of this National Technical Approval shall be in full. However, partial reproduction can be made with the written consent of the Deutsches Institut für Bautechnik. Texts and drawings of advertising brochures shall not contradict the National Technical Approval. In case of differences between the German version of the approval and the English translation, the German version is valid. Translations of the National Technical Approval shall include the note “Translation from the German original text not certified by Deutsches Institut für Bautechnik”.
7. This National Technical Approval is not granted irrevocably. The provisions of the National Technical Approval may be subsequently amended or modified, particularly if made necessary as a result of new technical developments.

II. SPECIFIC PROVISIONS

1 Definition of product and intended use

1.1 Definition of the construction product

This National Technical Approval applies to hot-rolled and heat-treated steel bar anchors St 900/1100 with thread ribs and a nearly circular cross section. The nominal diameter is 15.0 mm or 20.0 mm. Two opposing rib rows are rolled onto its surface to form a single right-hand thread (see Annex 1).

1.2 Intended use

Steel bar anchors St 900/1100 with thread ribs are suitable for use as form ties and components of scaffold anchors. They will hereinafter be referred to as steel bar anchors AWM 1100.

2 Provisions for bar anchors AWM 1100

2.1 Characteristics and composition

2.1.1 Dimensions and weight per meter

(1) Nominal diameter, nominal weight, nominal cross section and cross sectional tolerances are specified in Annex 1. The thread tolerance data have been deposited with the Deutsches Institut für Bautechnik.

(2) The value resulting from the cross section area tolerance of -2% is defined as the 5% fractile of the main unit. Production shall be adjusted so as to ensure that the mean cross section area \bar{A}_s is not smaller than the nominal cross section.

(3) The cross section area \bar{A}_s is determined by weighing. Thereby, the apparent density of the steel is assumed to be 7.85 g/cm³. The cross section area calculated from the weight must be reduced by 3.5%, since the threaded ribs contribute only partly to the load transfer. The value reduced by 3.5% shall also be used to determine the mechanical properties.

2.1.2 Mechanical properties

(1) The requirements for the mechanical-technological properties of the steel bar anchor AWM 1100 are specified in Annex 2.

(2) The data listed in Annex 2 are fractile values relative to the main unit; the characteristics yield strength $R_{p0.2}$, tensile strength R_m , elongation at fracture $A_{11,3}$ and overall elongation at ultimate load A_{gt} may be lower than the required values by maximally 5%.

(3) The 95%-fractile of the tensile strength R_m of one production run (melt or batch) may not exceed 1,250 N/mm².

2.1.3 Composition

The chemical composition and manufacturing conditions for steel bar anchors AWM 1100 in accordance with this National Technical Approval have been deposited with the Deutsches Institut für Bautechnik.

2.2 Production, transport, storage and marking

2.2.1 Production

Steel bar anchors St 900/1100 are hot-rolled and tempered from the rolling heat. On the surface two opposite rows of ribs are rolled, that complement the ribs to a catchy right-hand thread.

2.2.2 Packing, transport, storage

(1) Normally, the steel bar anchors AWM 1100 are delivered in a straight bar shape, singly or bundled. In exceptional cases, steel bar anchors AWM 1100 may be delivered in a bent shape; in this case the data specified in section 3.4 must be fully observed. The data specified in section 3.4 (3) and (4) shall be added to the delivery note according to section 2.2.3.

(2) Steel bar anchors AWM 1100 shall always be free from corrosion-stimulating substances (e.g. chlorides, nitrates, acids).

(3) Special care shall be taken to ensure that the steel bar anchors AWM 1100 are not mechanically damaged or soiled.

2.2.3 Marking and delivery note

(1) The steel bar anchors AWM 1100, bundled and cut to specifications or into standard delivery lengths shall be provided with a weather and mechanical damage resistant label that includes the following information:

Manufacturing plant: ...	<u>Caution! Sensitive Steel bar anchor!</u>
Steel bar anchor AWM 1100 according to Approval No.	
Type: St 900/1100 – threaded	Transport and store protected against corrosion!
Nominal diameter: ...mm	Do not damage, do not soil!
Melt No.: ...	
Order No.: ...	
Date: ...	

(2) The delivery note of the steel bar anchor AWM 1100 shall contain the same information as the label according to 2.2.3 (1). In addition, the manufacturer shall affix the conformity marking (CE-marking) on the delivery note in accordance with the conformity marking regulations of the German federal states. The CE-marking may only be affixed, if the requirements according to section 2.3 for the attestation of conformity are met.

2.3 Attestation of Conformity**2.3.1 General**

(1) To attest the steel bar anchors' conformity with the provisions of this National Technical Approval a certificate of conformity shall be issued for each manufacturing plant based on factory production control and continuous surveillance including initial type-testing of the bar anchors in accordance with the following provisions.

(2) The manufacturer of the steel bar anchors AWM 1100 shall involve an approved certification body to issue the certificate of conformity and an approved inspection body to perform continuous surveillance including product inspection.

(3) The manufacturer shall declare that a certificate of conformity has been granted by affixing the conformity marking (CE marking) onto the construction product including indication of the intended use.

(4) The certification body shall submit a copy of the issued certificate of conformity to the Deutsches Institut für Bautechnik.

(5) In addition, a copy of the initial type testing report must be submitted to the Deutsches Insitiut für Bautechnik.

2.3.2 Factory production control

(1) Each manufacturing plant shall establish and implement a factory production control system. Factory production control entails the permanent internal control of production exercised by the manufacturer in order to ensure that the construction product produced by him is in conformity with the provisions of this National Technical Approval.

(2) Factory production control shall at least include the elements specified in the “Approval and inspection guidelines for prestressing steel”, issued in 2004 by the Deutsches Institut für Bautechnik. Testing of fatigue strength, relaxation and resistance to hydrogen-induced stress corrosion cracking is not required.

In addition, the reduction in the load-bearing capacity following a one-time bending to and fro by 180° (bending block diameter $6 \cdot d_p$) shall be tested. Reduction of the tensile strength may not exceed 10%.

(3) The results of factory production control shall be recorded and evaluated in accordance with the criteria specified in the guidelines. The records shall include at least the following information:

- Identification of the construction product or raw material
- Type of control or test
- Date of production and testing of the construction product or raw material
- Results of controls and tests and comparison with requirements
- Signature of the person responsible for factory production control

(4) The records shall be kept for at least five years and shall be submitted to the inspection body responsible for continuous surveillance. On request, these records shall be submitted to the Deutsches Institut für Bautechnik and the relevant supreme building control authority.

(5) In case of unsatisfactory test results, the manufacturer shall take immediate measures to eliminate the deficiency. Construction products that do not comply with the requirements shall be handled such that they cannot be mistaken for products complying with the requirements. After elimination of the deficiency the respective test shall be immediately repeated as far as is technically possible and necessary to verify that the deficiency has been eliminated.

2.3.3 Continuous surveillance

(1) Factory production control of each manufacturing plant shall be verified by continuous surveillance, at least however twice a year.

(2) During surveillance inspections, tests in accordance with the guidelines specified in section 2.3.2 (2) shall be performed. In addition, the reduction in the load-bearing capacity following a one-time bending to and fro shall be tested according to 2.3.2 (2). Surveillance shall also include the taking of samples for audit testing. The respective approved inspection body is responsible for sampling and testing.

(3) The results of certification and surveillance shall be kept for at least five years. On request, they shall be submitted by the certification body or inspection body to the Deutsches Institut für Bautechnik and the relevant supreme building control authority.

3 Provisions for design and dimensioning

3.1 Verification

(1) For all possible load combinations the following shall be verified:

$$S_d \leq R_d$$

where:

S_d = design value of actions

R_d = design value of load-bearing capacity

$$S_d = \gamma_F \cdot S_k$$

where:

S_k = characteristic value of actions

γ_F = partial safety factor of actions

$$R_d = R_k / \gamma_S$$

where:

R_k = characteristic value of load-bearing capacity

γ_S = partial safety factor of material resistance

3.2 Partial safety factors

(1) Use of bar anchor as form tie

Partial safety factor for actions

$$\gamma_F = 1.5$$

Partial safety factor for steel bar anchor AWM 1100

$$\gamma_S = 1.15$$

(2) Use of bar anchor as component of scaffold anchors

The partial safety factors are specified in the respective approvals of the scaffold anchors.

3.3 Modulus of elasticity

For calculation purposes, the modulus of elasticity is assumed to be 202,000 N/mm².

3.4 Bending

(1) Smaller radii of curvature than $R = 6 \cdot d_p$ are not permissible.

(2) For cold bending, only machines may be used that produce an even curvature and do not cause damage (abrasions) to the steel.

(3) In the area of curvature, cold-forming reduces the strength properties defined in Annex 3 to 80% of the initial values.

(4) Back-bending is not permitted.

(5) The areas of the curvature radii must be free of weld spatter.

3.4 Bond

(1) The bond behaviour was not verified in the course of the approval procedure.

4 Provisions for installation

- (1) The relevant provisions (e.g. standards, guidelines) for the handling and protection of the steel bar anchor AWM 1100 at the installation site shall be observed.
- (2) Prior to installation, the steel bar anchor AWM 1100 shall be carefully examined for corrosion pits. If corrosion pits are discovered, the steel bar anchor AWM 1100 shall be disposed of.
- (3) The steel bar anchor AWM 1100 shall also be protected against mechanical damage during installation. Damaged steel bar anchors AWM 1100 may not be used.
- (4) The steel bar anchor AWM 1100 may not be welded since its suitability for welding was not verified in the course of the approval procedure.
- (5) An attachment of the reinforcement at the anchor steel and ignition points and current brands of adjacent welds and improper welding current leadership are not allowed.
- (6) Weld spatter from adjacent welds (e.g. on reinforcement) does not affect the performance characteristics of steel bar anchors AWM 1100 to be used as form ties.

Unless otherwise stated in this National Technical Approval, reference is made to the following documents:

DIN EN ISO 15630-3:2011-02 Stähle für die Bewehrung und das Vorspannen von Beton –
Prüfverfahren – Teil 3: Spannstähle (ISO 15630-3:2010);
Deutsche fassung EN ISO 15630-3:2010

Deutsches Institut für Bautechnik: “Richtlinie für Zulassungs- und Überwachungsprüfungen für
Spannstähle“ [Guideline for approval and inspection testing],
edition 2004

Dr. Ing. Lars Eckfeldt
Head of division

Shaping

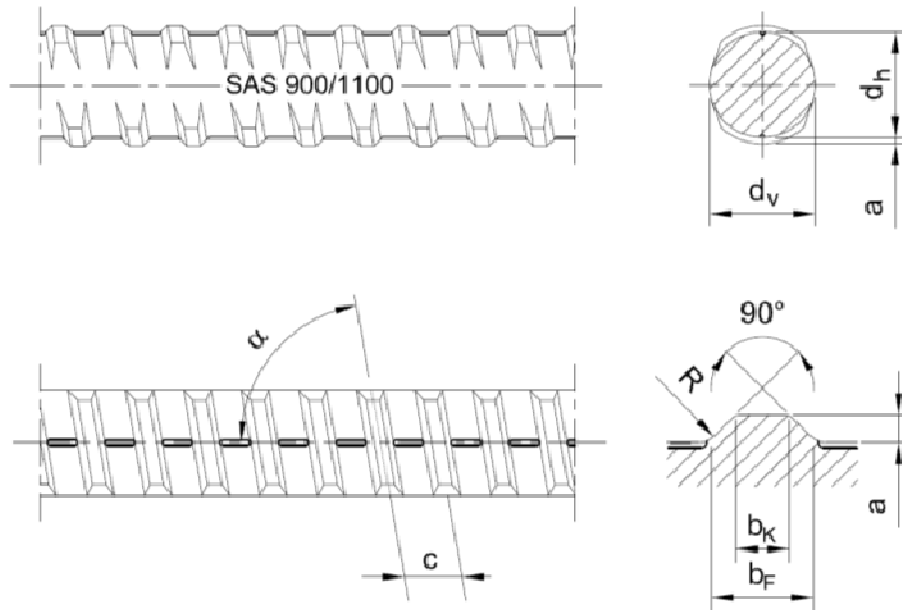

Nominal diameter	Nominal weight ¹⁾	Nominal cross section	Core diameter		Thread ribs (right-hand)					
					Height	Width (foot)	Width (head)	Spacing	Pitch	Radius
$\varnothing p = dp$	g	A_p	d_h	d_v	a	b_f	b_k	c	α	R
mm	kg/m	mm ²	mm	mm	mm	mm	mm	mm	degree	mm
15,0	1,41	173	14,8	14,7	1,15	4,8	2,5	10,0	78,5	1,5
20,0	2,51	309	19,8	19,6	1,30	4,8	2,2	10,0	81,5	2,0

¹⁾ Weight includes 3.5% non-load-bearing thread ribs. Tolerance +3% / -2%

The information for tolerances of the core diameter to the dimensions of the thread ribs and screwability are deposited with the external auditor and DIBt.

Steel bar anchor St 900/1100 with thread ribs AWM 1100	Attachment 1
Nominal dimensions and nominal weight , rib geometry	

Strength properties						
	Nominal diameter	0,2% - Yield strength	Tensile strength	Characteristic		Value p ¹⁾
				Strength at 0.2 % elongation (yield load)	Ultimate load	
	d_p	R_{p0,2}	R_m	F_{p0,2}	F_m	
	[mm]	[N/mm ²]	[N/mm ²]	[kN]	[kN]	[%]
1	15,0	900	1100	156	190	5,0
2	20,0	900	1100	278	340	5,0
Deformation properties						
						value p ¹⁾ [%]
1	Elongation at fracture		A _{11,3}	[%]	7	5,0
2	Elongation at ultimate load (calculated from $A_g + R_m/E \cdot 100\%$) ²⁾		A _{gt}	[%]	3	5,0
3	Pin diameter for folding test acc. DIN EN ISO 15630-3:2011-02, section 6. Bending angle 180°		d _{br}	[mm]	4•d _p	-- ³⁾
4	Maximum load capacity drop after one round trip bending by 180° (bending diameter: d _{br} = 6 * d _p) acc. DIN 488-1:1987-09		T	[%]	10	-- ³⁾
5	Notched bar impact work ISO-V (-20°C)			[J]	≥ 27	-- ³⁾
<p>1) Quantile for a statistical probability of $W = 1 - \alpha = 0.95$ (one side)</p> <p>2) E_p 202 000 N/mm²</p> <p>3) Each individual value</p>						
Steel bar anchor St 900/1100 with thread ribs AWM 1100						Attachment 2
Nominal dimensions and nominal weight , rib geometry						