

The Formwork Experts.

Transport fork 1.3t adjustable

Art. n°: 586234000

Original Operating Instructions

Please retain for future reference

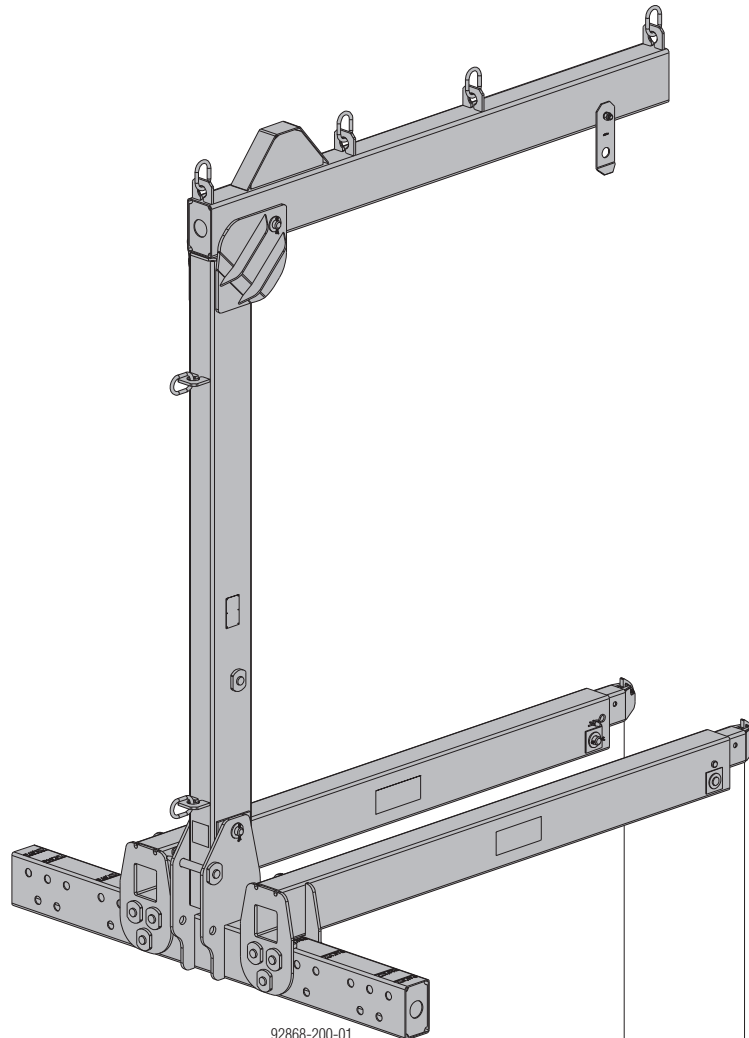

92868-200-01

Contents

3 General

- 3 Intended use
- 4 Product presentation
- 5 Permitted working load limit
- 6 Maintenance / inspection / storage
- 7 Selecting the lifting chain
- 8 Functional description

9 Preparation for use

- 9 Offloading on the site
- 10 Assembly
- 12 Setting the transport fork

15 Additional precautions

- 15 Table fixing part

16 Repositioning operation

18 Dismantling

21 Article list

22 Declaration of conformity

General

Intended use

The 'Transport fork 1.3t adjustable' is a lifting accessory. It is designed to be used for repositioning Doka tableforms, Doka balcony tables and ParaTop platforms (intended use).



NOTICE

- Other use or use not in conformity with that stated above is non-intended use and requires the prior written approval of the Doka company!
- Repositioning tables or platforms of other manufacturers is prohibited!

Product presentation

Component overview

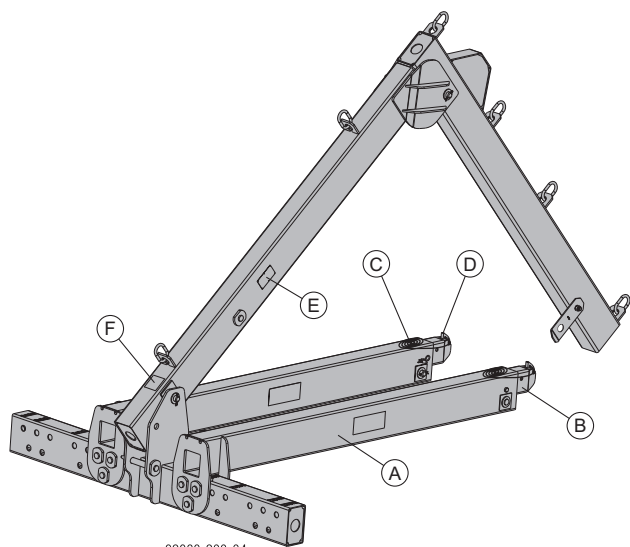

- A** Fork profile (adjustable)
- B** Telescopic tube
- C** Tag-line d10/5000 mm
- D** Lever-latch
- E** Type plate
- F** Warning label

Data on type plate

- Art. n°: 586234000
- Designation: Transport fork 1.3t adjustable
- Dead weight: 718 kg (1580 lbs)
- Max. working load limit: 1300 kg (2870 lbs)
- Graph: Working load limit depending on load centre
- Max. permitted eccentricity when fully loaded: 15 cm
- Year of manufacture: see type plate
- Serial n°: see type plate
- QR code: Information on basis of serial numbers on id.doka.com



Safety notes (warning labels) on the product

- Danger of crushing!



Sizes

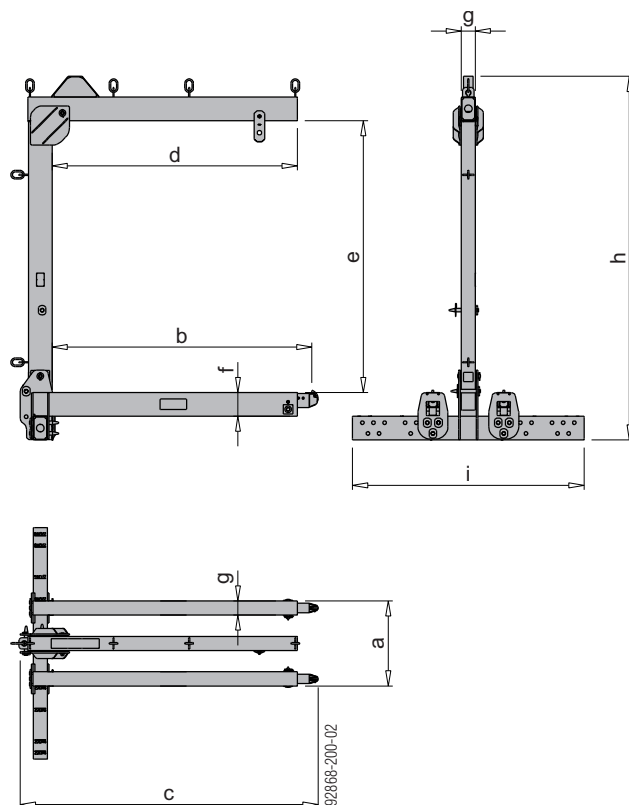

Delivery condition

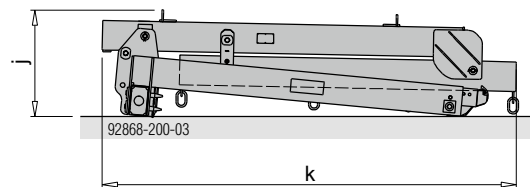

- a ... 90, 137, 204 or 227 cm
- b ... 275, 324, 373 or 422 cm
- c ... 315, 364, 413 or 462 cm
- d ... 259.5 cm
- e ... 287.6 cm
- f ... 25 cm
- g ... 15 cm
- h ... 384.6 cm
- i ... 245 cm
- j ... 90.5 cm
- k ... 350.8 cm

Permitted working load limit

Working load limit depending on load centre:

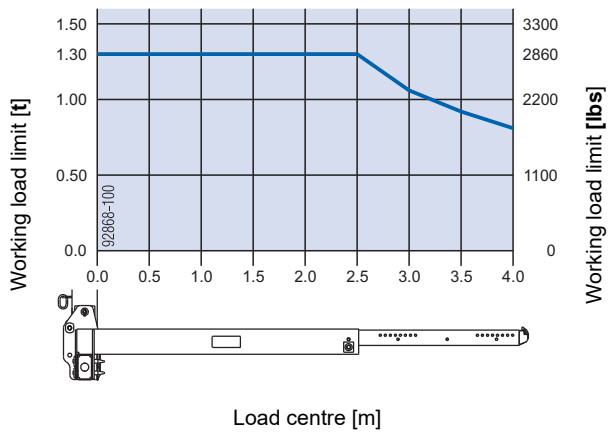

The maximum working load limit is valid up to the 2.5 m **load centre offset point**.

Max. permitted eccentricity when fully loaded:
15 cm

Maintenance / inspection / storage

Maintenance & inspection

- Repairs may only be carried out by the manufacturer!
- Doka accepts no liability for products that have been altered!

Before every use

- ▶ Check for any signs of damage or visible deformation.



Lifting accessories that do not meet the following criteria must be withdrawn from use immediately:

- Crack-free and notch-free welds.
- No deformation.
- The type plate and all adhesive labels must be in place, and must be clearly legible.

At regular intervals

- Inspection of lifting accessories must be performed at regular intervals by an **expert** in conformity with **national statutory provisions**. Unless otherwise stipulated, such inspection must be carried out **at least once a year**.

Storage

- Store lifting accessories in a dry and well ventilated place, protected from the weather and from all corrosive substances.

Selecting the lifting chain

Required **working load limit** of the 2-part **lifting chain**:

Up to 30° sling angle β : **2500 kg**

Note:

- The tableforms or platforms always have to be as nearly horizontal as possible for each repositioning operation.
- Of the 3 possible attachment possibilities, always select the one that is the most suitable for the load's centre of gravity.

Attachment possibilities for 2-part lifting chain:

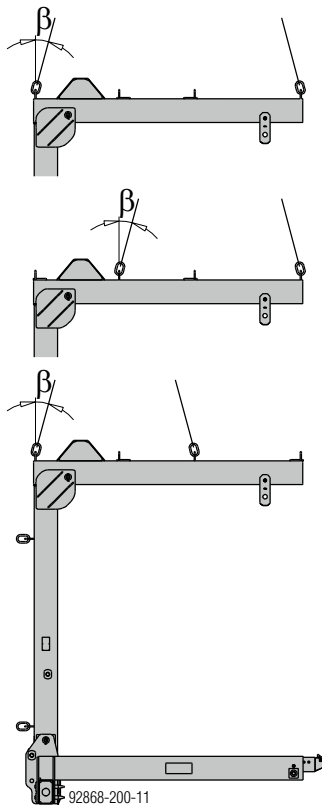

β ... max. 30°



NOTICE

- The longer the crane lifting tackle (2-part lifting chain), the more easily the transport fork will hang in the horizontal, both when under load and when not under load.
- Sling angle β max. 30°!
- Recommended length of crane lifting tackle min. 3.0 m.



If the lifting height of the crane is not sufficient in the top storey, shorter lifting chains may be used, provided that the following points are observed.

- Sling angle β max. 30°!
- Use chains with adjustable lengths.

Functional description

'Parked' position

Attaching/detaching the 2-part lifting chain is easy, as the bracket automatically tilts down into the parking position when it is placed on the ground.

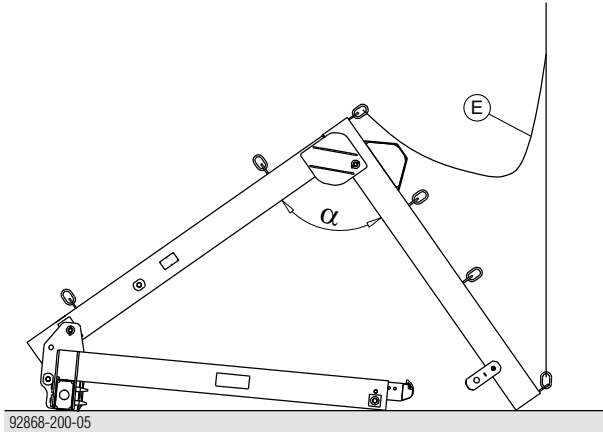

α ... min. 90°

E 2-part lifting chain

Possible operator error



WARNING

Danger of crushing!

- It is forbidden to raise the transport fork (e.g. by forklift truck or lifting slings) from underneath the fork profiles!

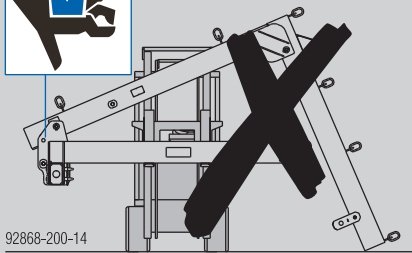

Lever-latch

The lever-latch acts as an anti-slide-off guard when tableforms or platforms are being lifted.

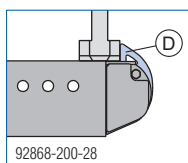

D Lever-latch

Tag-lines

The tag-lines make it easier and safer to guide the transport fork when manoeuvring it under the tableforms or platforms.

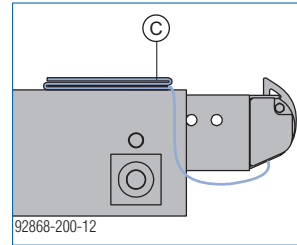

C Tag-line d10/5000 mm

Telescopic tube

Extend the telescopic tubes to the length appropriate for the table or platform size and pin the tubes in position.

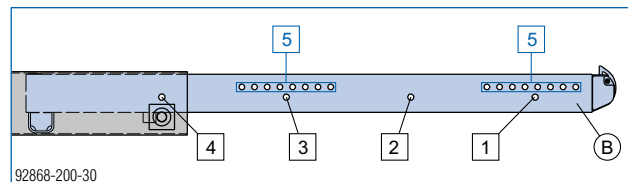

1, 2, 3, 4 ... Pinning positions for setting the length of the forks

5 ... Pinning positions for 'Transport-fork table-fixing part 1.3t adj.'

B Telescopic tube

Preparation for use

Offloading on the site



- ▶ During the crane operation, all persons must stay a safe distance away from the transport fork to avoid unsafe conditions and eliminate any hazards or exposure to injury!



NOTICE

Make sure that the transport fork is in the centre-of-gravity position when it is being unloaded.

Using 2-part lifting chain

Note:

Fork-bolt must be pinned in position 1 (transport lock)!

- ▶ Offload the transport fork from the truck using a crane and 2-part lifting chain.

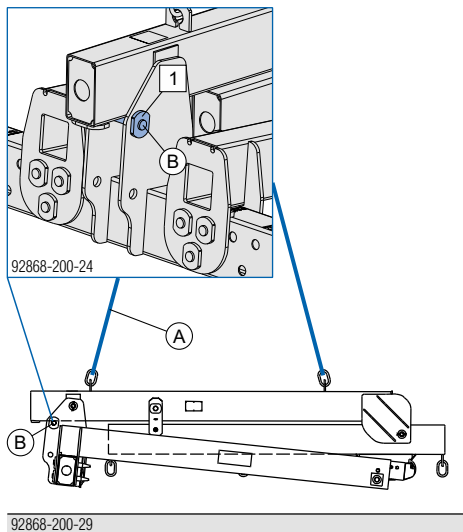

- A 2-part lifting chain
- B D37 fork-bolt

Using the Dokamatic lifting strap 13.00m

- ▶ Offload the transport fork from the truck using 2 Dokamatic lifting straps 13.00m.

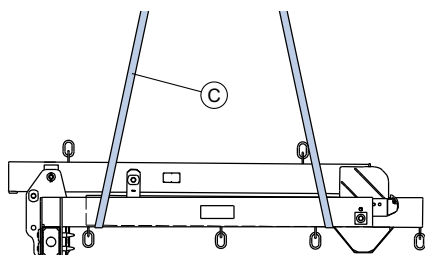

- C Dokamatic lifting strap 13.00m

By forklift truck

- ▶ Offload the transport fork from the truck using a forklift truck.

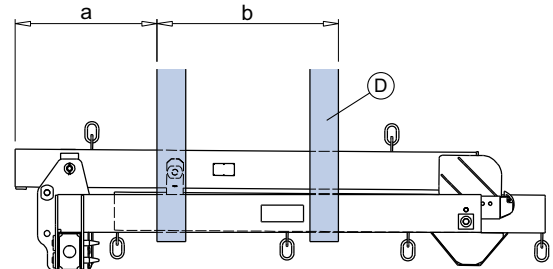

- a ... 90 cm
- b ... 120 cm

- D Fork of the forklift truck

Assembly



▶ During the crane operation, all persons must stay a safe distance away from the transport fork to avoid unsafe conditions and eliminate any hazards or exposure to injury!

- ▶ Set the fork down on level ground.
- ▶ Remove the fork bolt D37 from Pos. 1.

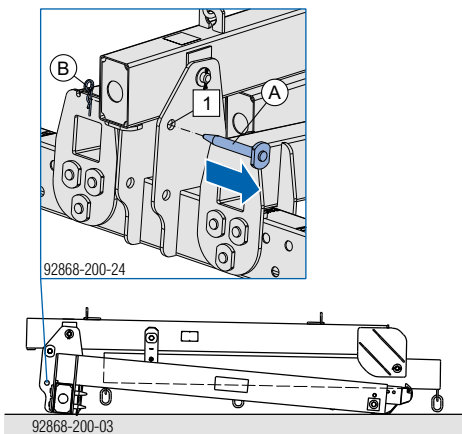

- A Fork bolt D37
- B Spring cotter D6 with double eye

- ▶ Hook the crane hook of the first strand of the 2-part lifting chain in at Pos. 4.

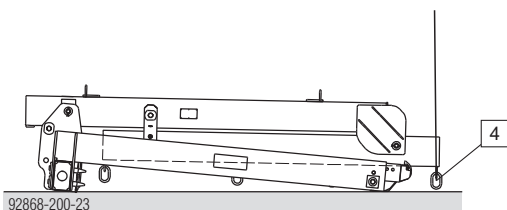

- ▶ Raise the lifting extension bracket by crane.

- ▶ Insert the fork bolt D37 into Pos. 1 and fix it with a Spring cotter D6.

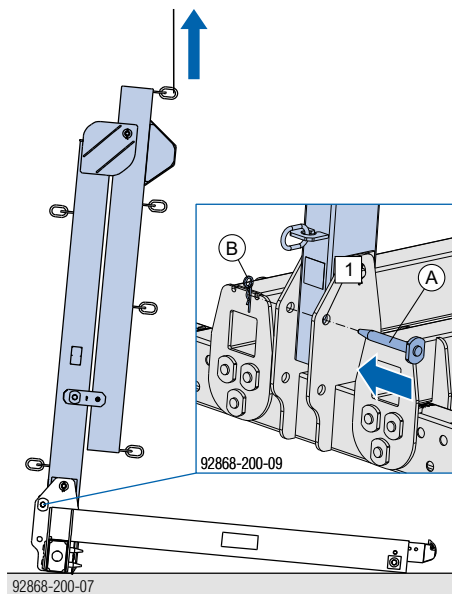

- A Fork bolt D37
- B Spring cotter D6 with double eye

- ▶ Remove the fork bolt D37 from Pos. 3.

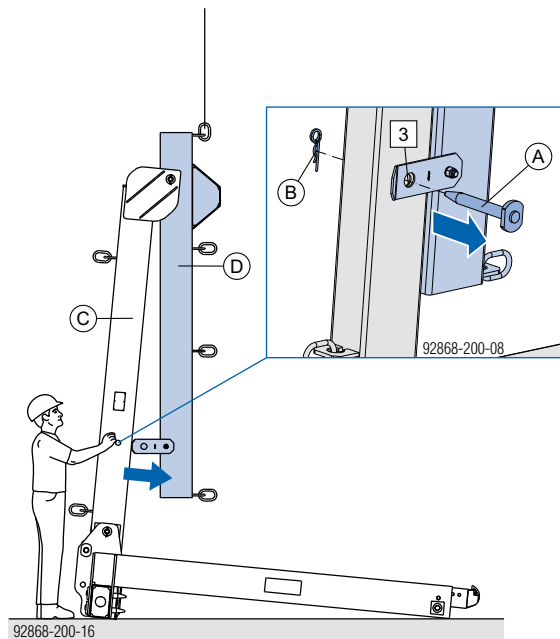

- A Fork bolt D37
- B Spring cotter D6 with double eye
- C Upright tube
- D Lifting extension-bracket tube

The lifting extension-bracket tube will now tilt towards the front.

- ▶ Push the fork bolt D37 back into Pos. 3 on the upright tube, and fix it with a Spring cotter D6.
- ▶ Lower the crane lifting tackle until the crane hook of the second strand is within reach.
- ▶ Hook the crane hook in at Pos. 5.

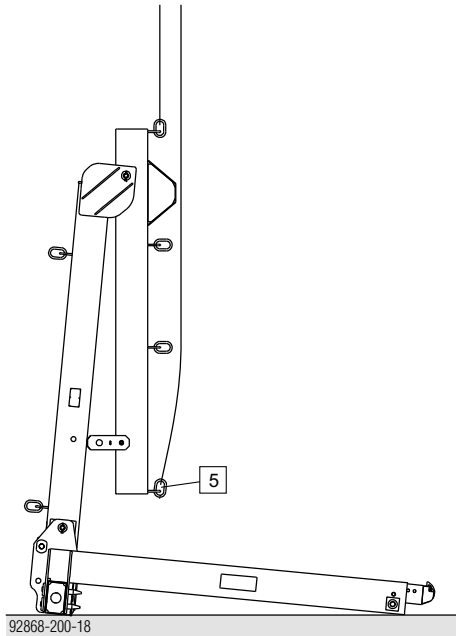

- ▶ Raise the entire transport fork by crane. The transport fork is now suspended above the ground.
- ▶ Remove the fork bolt D37 from Pos. 1.

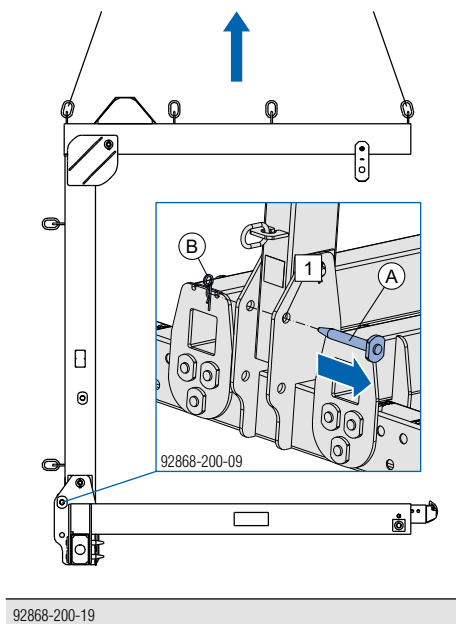

- A** Fork bolt D37
- B** Spring cotter D6 with double eye

- ▶ Set down the transport fork and carefully lower the lifting extension bracket into the 'parked' position.
- ▶ Insert the fork bolt D37 (previously removed from Pos. 1) into Pos. 2, and fix it with a Spring cotter D6.

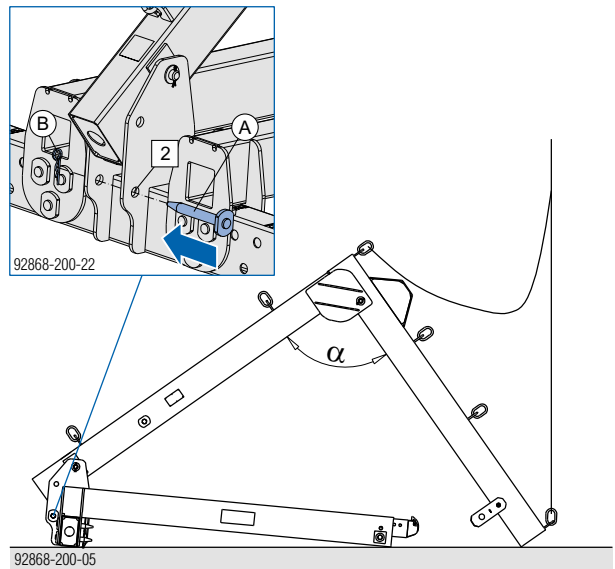

α ... min. 90°

- A** Fork bolt D37
- B** Spring cotter D6 with double eye

- ▶ The transport fork is now ready for operation.

Note:

No fork bolt is allowed in Pos. 1 at any time while the transport fork is in use!

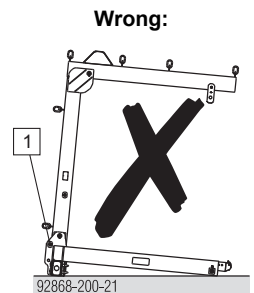
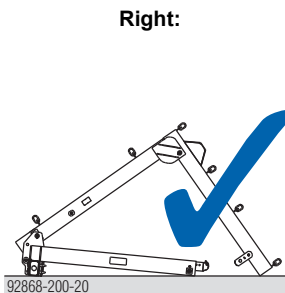

Setting the transport fork



NOTICE

- Always adjust the fork profiles one at a time!
- The fork profiles must always be positioned symmetrically.
- The Transport fork 1.3t adjustable must be resting on level ground, with the lifting extension bracket in the 'Parked' position.

Setting the fork width

Note:

Required minimum width of the forks:

$\frac{1}{3}$ of the width of the table

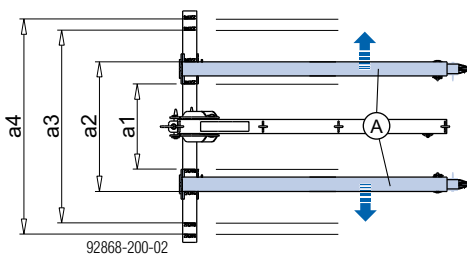

Fork widths a1 - a4

- a1 ... 90 cm
- a2 ... 137 cm
- a3 ... 204 cm
- a4 ... 227 cm

A Fork profile

- ▶ Remove all three fork bolts D37 from Pos. 6.
- ▶ Keeping the first fork profile parallel with the second fork profile, move it as far as the desired width-mark.
- ▶ Bolt all three fork bolts D37 into Pos. 6, and fix with the Spring cotter D6.

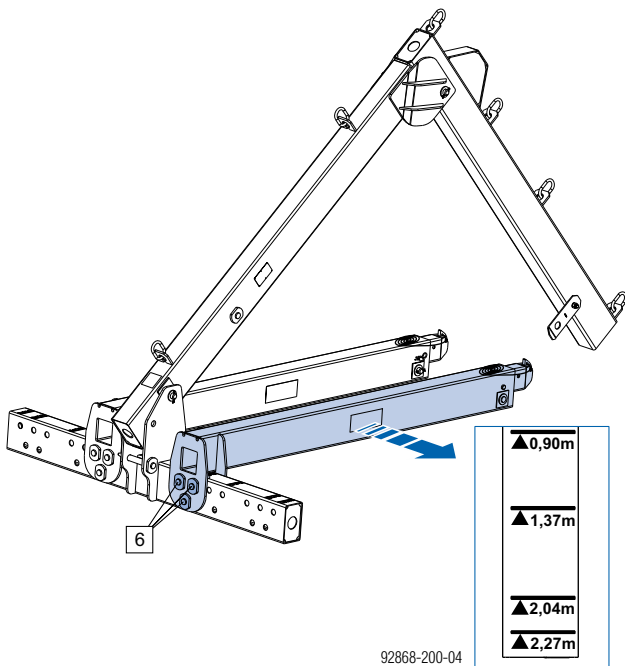

- ▶ Keeping the second fork profile parallel with the first, move it as far as the corresponding width-mark.

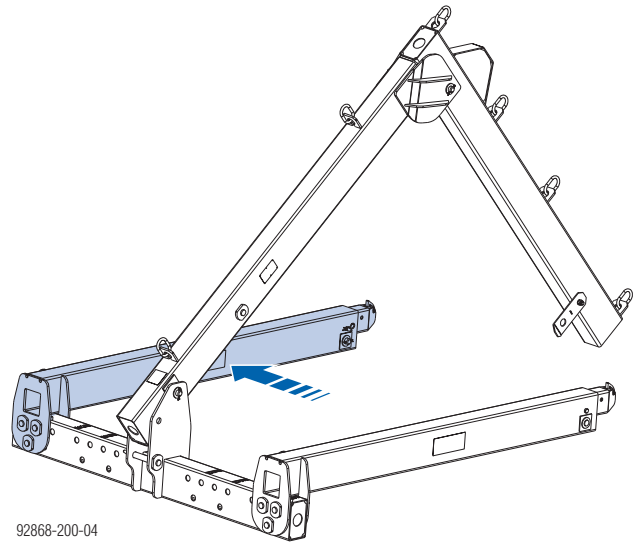

Use with DokaXdek and Dokamatic tables

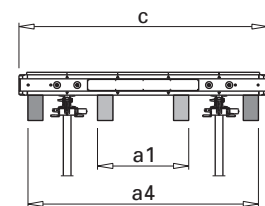
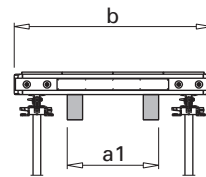

Fork widths:

- a1 ... 90 cm
- a4 ... 227 cm

Table widths for DokaXdek tables:

- b ... 200 cm
- c ... 250 cm

Table widths for Dokamatic tables:

- b ... 195 cm
- c ... 245 cm

Setting the fork length

Note:

Required minimum length of the forks:
 $\frac{2}{3}$ of the length of the table

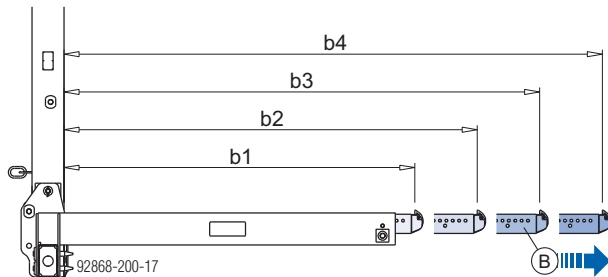

Fork lengths b1 - b4

b1 ... 275 cm

b2 ... 324 cm

b3 ... 373 cm

b4 ... 422 cm

B Telescopic tube

- ▶ Remove the pin D20 from Pos. 7.
- ▶ Extend the telescopic tubes to the required length.
- ▶ Push the pin D20 back into Pos. 7, and secure it with a Spring cotter 5mm.

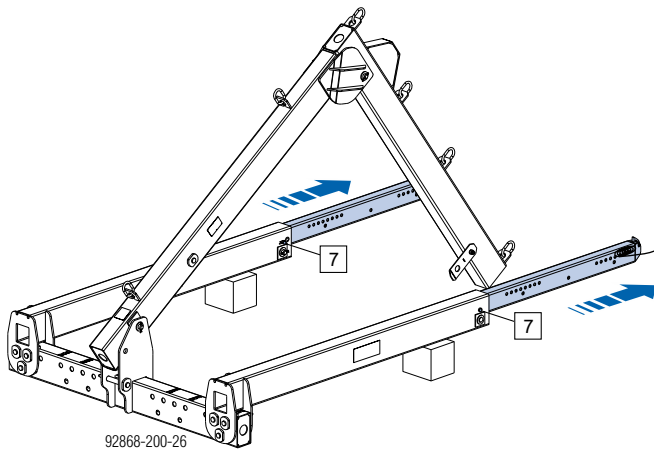

Use with DokaXdek and Dokamatic tables

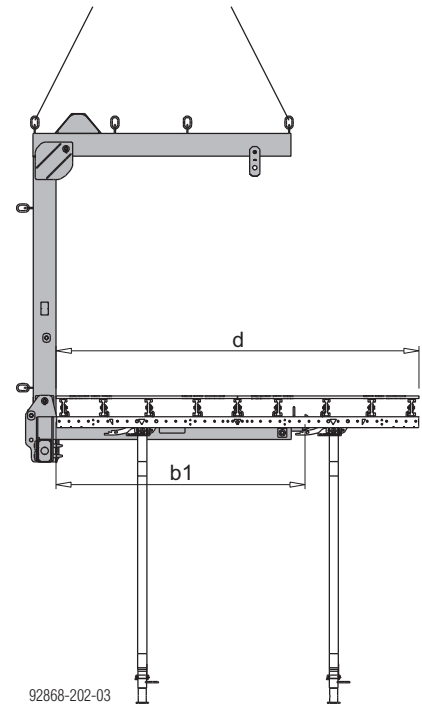

b1 ... 275 cm
 d ... 400 cm

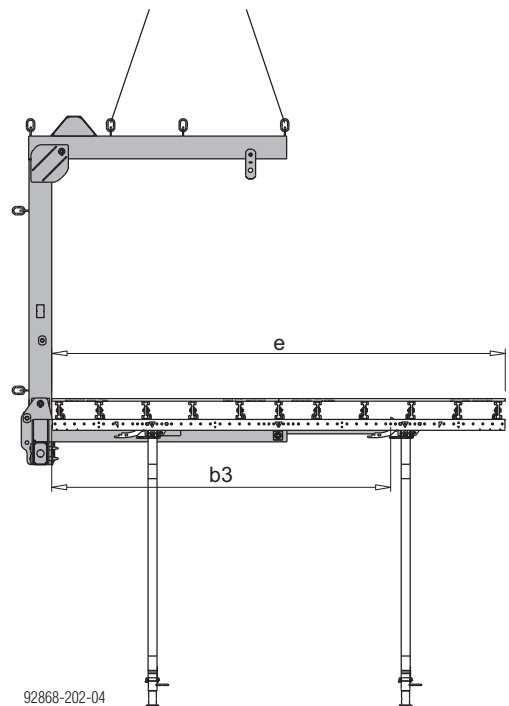

b3 ... 373 cm
 e ... 500 cm

**DokaXdek table placed across the direction of the fork
(e.g. balcony table):**

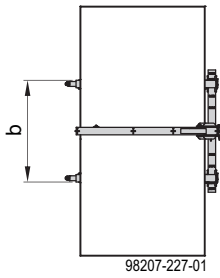
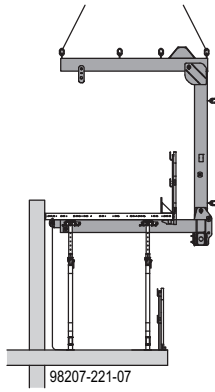

- a ... Fork width 1.37 m for table width 4.00m
- a ... Fork width 2.04 m for table width 5.00m

Note:

For use with table across the forks, pin the forks at their shortest length.

**Dokamatic table placed across the direction of the fork
(e.g. balcony table):**

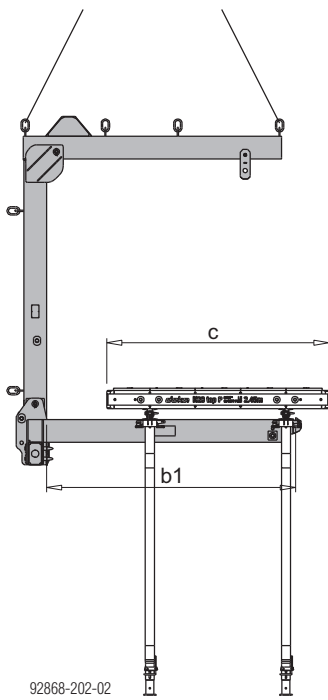

- b1 ... 275 cm
- c ... 245 cm

Using with ParaTop platforms

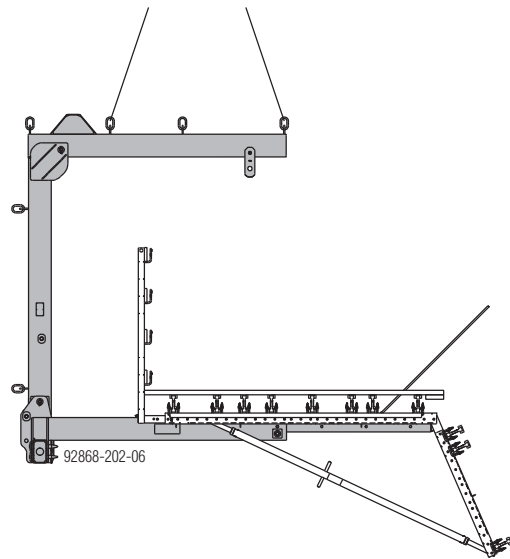
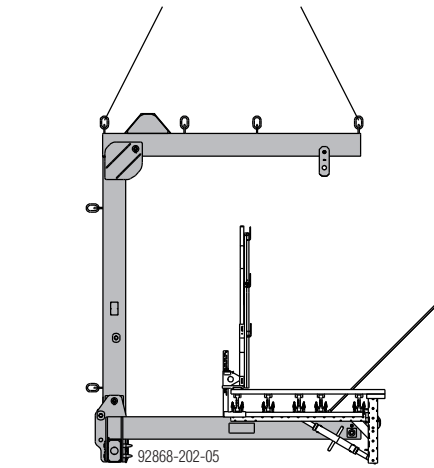

Additional precautions

Table fixing part

The Transport-fork table-fixing part 1.3t adj. is for securing Dokamatic tables placed across the direction of the fork (e.g. balcony table) for the repositioning operation.

- Position the table-fixing parts on the transport fork, pin each of them with a pin D20 and secure each pin with a spring cotter.

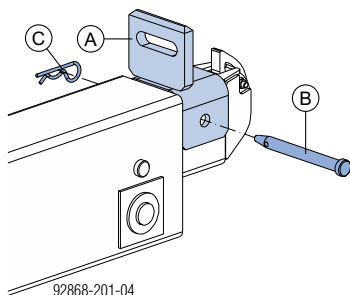

A Transport-fork table-fixing part 1.3t adj.

B Pin D20

C Spring cotter 5mm

- Move the transport fork in underneath the table and position the table-fixing part in the table waling.
- Pin each table-fixing part to the table waling with a Connecting pin 10cm, and secure with a spring cotter.

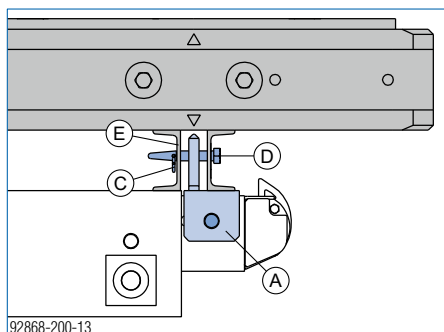

A Transport-fork table-fixing part 1.3t adj.

C Spring cotter 5mm

D Connecting pin 10cm

E Table waling



NOTICE

After table set-down:

- Do not further lower the secured transport fork!
- First remove the connecting pins between the table-fixing parts and table walings, then lower the transport fork!

Repositioning operation



WARNING

Risk of intermediate props dropping out when table is lifted

- ▶ **Intermediate props** with a Supporting head H20 DF, and props that are only secured against tipping over, must be **removed** before the table is lifted.
- ▶ Intermediate props that are attached by an **Intermediate head DF** and are not dismounted must be pulled in sufficiently far.



WARNING

- ▶ 'Passenger transportation' is forbidden!
- ▶ Additional safety measures are needed for special, custom table constructions.
- ▶ Before repositioning the tableform, remove all loose items (e.g. fitting boards) from it.
- ▶ Check the connections between the floor props and the tableform before repositioning it.
- ▶ Before lifting, fix the floor props with the fastening clamps.



- ▶ During the crane operation, all persons must stay a safe distance away from the transport fork to avoid unsafe conditions and eliminate any hazards or exposure to injury!



CAUTION

Risk of edge tables toppling over!
(due to cantilevering platforms, edge props that have been relocated towards the inside, stop-end formworks, downstand beams)

- ▶ Secure all edge tables **by tying back (A)** every primary beam in the inner cantilever zone of the table.
- ▶ Do not release the table from the shifting device until tie-backs are fixed to prevent tip-over.
- ▶ Also applies when setting down tables or putting them into temporary storage.

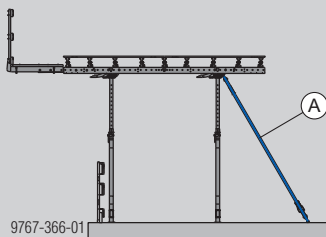

- ▶ Attach the lifting chain to the transport fork.

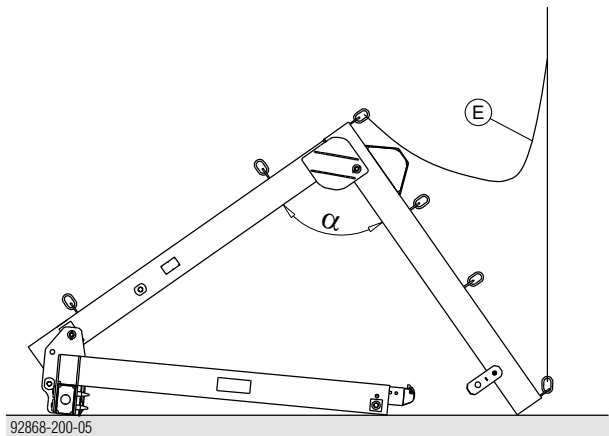

$\alpha \dots \text{min. } 90^\circ$

E 2-part lifting chain

- ▶ Raise the transport fork by crane.
- ▶ Manoeuvre the transport fork under the table.
- ▶ As necessary, secure the table to the transport fork with table fixing parts.

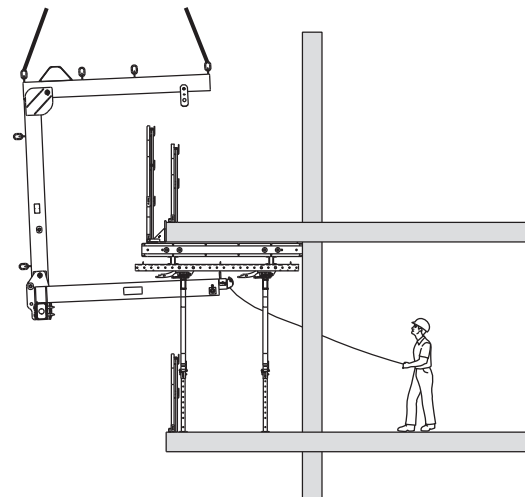

- ▶ Pick up the table with the transport fork, move it out and lift it.

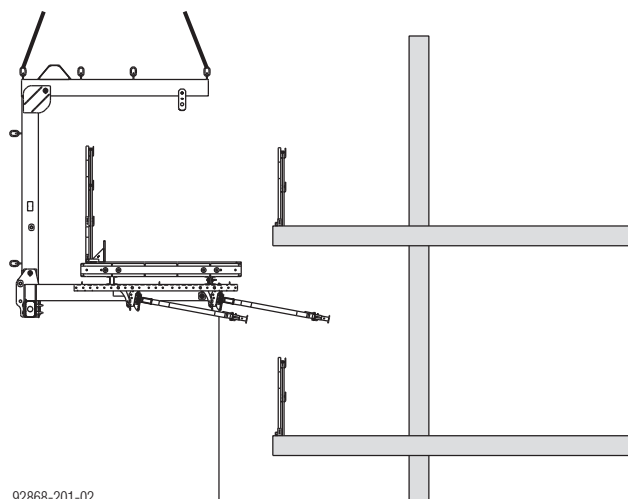

**WARNING**

- ▶ Check the connections between the floor props and the tableform before setting it down.
 - ▶ Before setting the table down, check whether the floor props have been fixed with the fastening clamps.
- ▶ Set the table down at its new location.

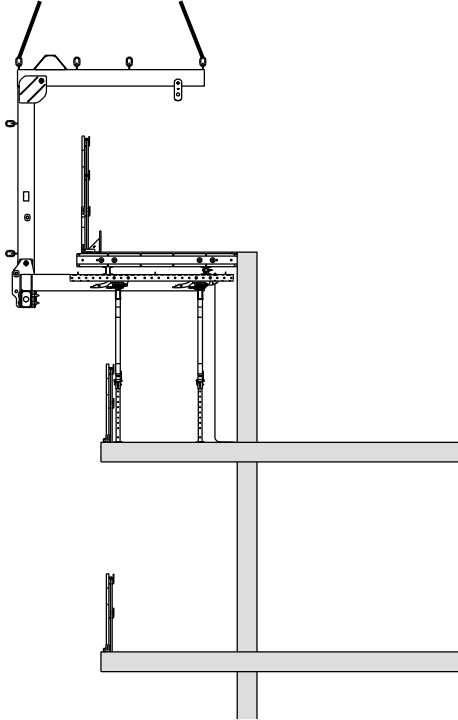

92868-201-03

- ▶ Secure the table so that it cannot tip over.
- ▶ Table fixing part in use: Remove the connecting pins between table fixing parts and table.
- ▶ Lower the transport fork and move it clear.

Dismantling



▶ During the crane operation, all persons must stay a safe distance away from the transport fork to avoid unsafe conditions and eliminate any hazards or exposure to injury!

- ▶ Attach the crane lifting tackle to the transport fork.
- ▶ Remove the fork bolt D37 from Pos. 2.

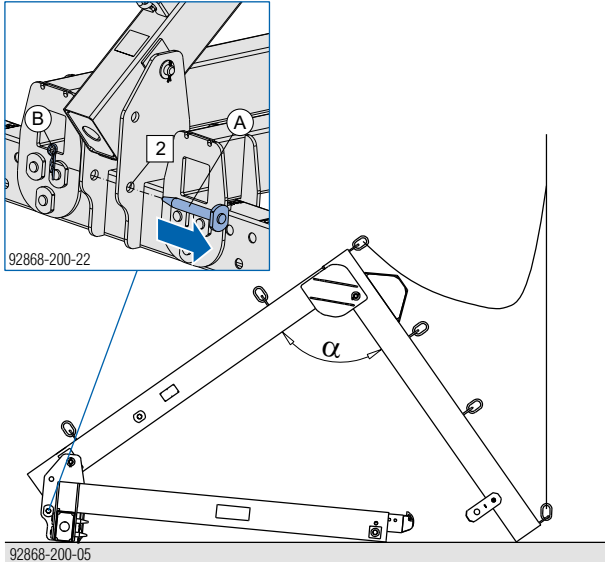

α ... min. 90°

- A Fork bolt D37
- B Spring cotter D6 with double eye

- ▶ Raise the entire transport fork by crane. The transport fork is now suspended above the ground.
- ▶ Insert the fork bolt D37 (previously removed from Pos. 2) into Pos. 1, and fix it with a Spring cotter D6.

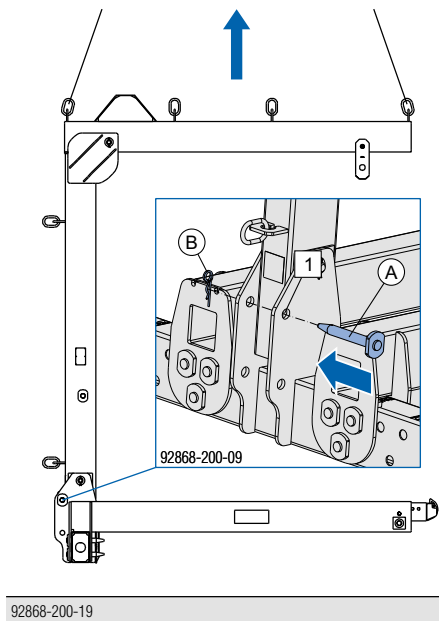

- A Fork bolt D37
- B Spring cotter D6 with double eye

- ▶ Set the fork down on level ground.

- ▶ Lower the lifting extension-bracket tube.
- ▶ Lower the crane lifting tackle until the crane hook of the second strand can be detached from Pos. 5.

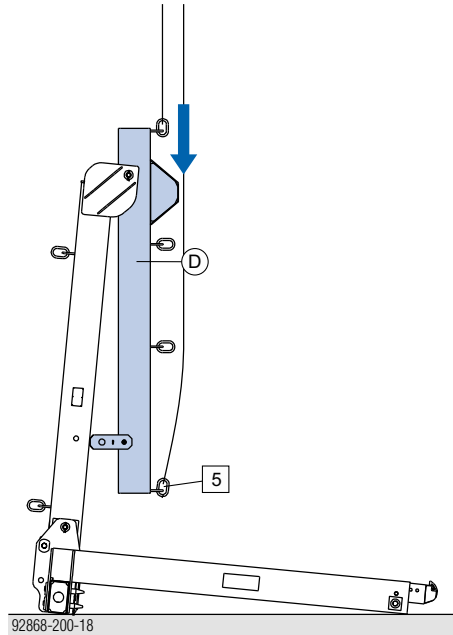

D Lifting extension-bracket tube

- ▶ Remove the fork bolt D37 from Pos. 3.
- ▶ Connect the lifting extension-bracket tube to the upright tube, insert the fork bolt D37 back into Pos. 3 and fix it with the Spring cotter D6.

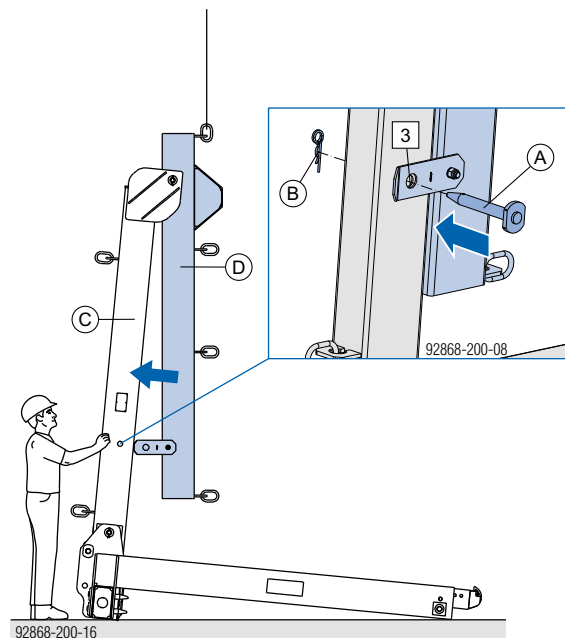

- A Fork bolt D37
- B Spring cotter D6 with double eye
- C Upright tube
- D Lifting extension-bracket tube

- ▶ Slightly raise the entire transport fork to take the load off the fork bolt D37.
- ▶ Remove the fork bolt D37 from Pos. 1.

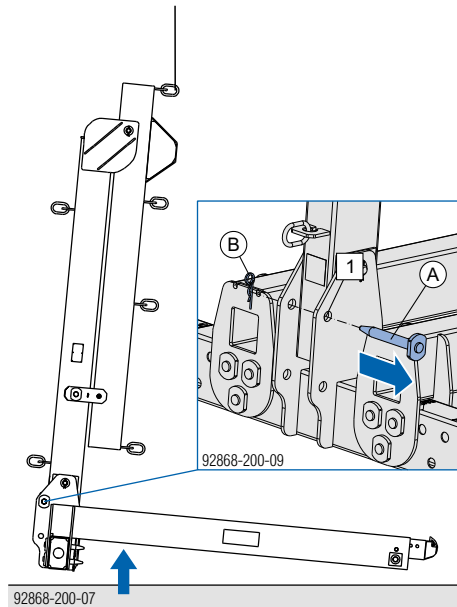

- A Fork bolt D37
- B Spring cotter D6 with double eye

- ▶ Set the fork down on level ground.

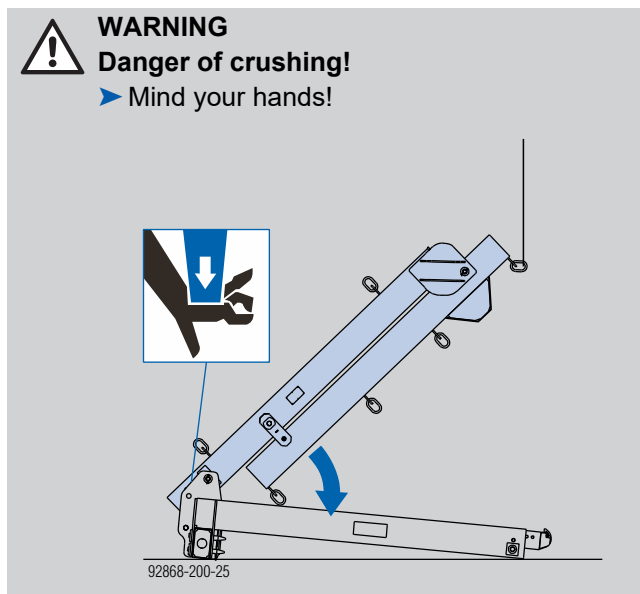

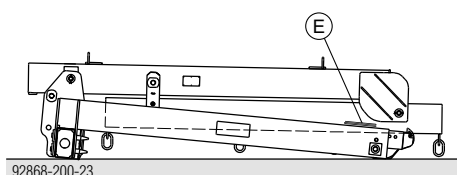

- ▶ Lower the lifting extension bracket to the ground by crane.
- ▶ Insert the fork bolt D37 into Pos. 1 as a transport lock, and fix it with the Spring cotter D6.
- ▶ Detach the crane hook.
- ▶ Bundle the tag-lines together so that they can be transported safely.

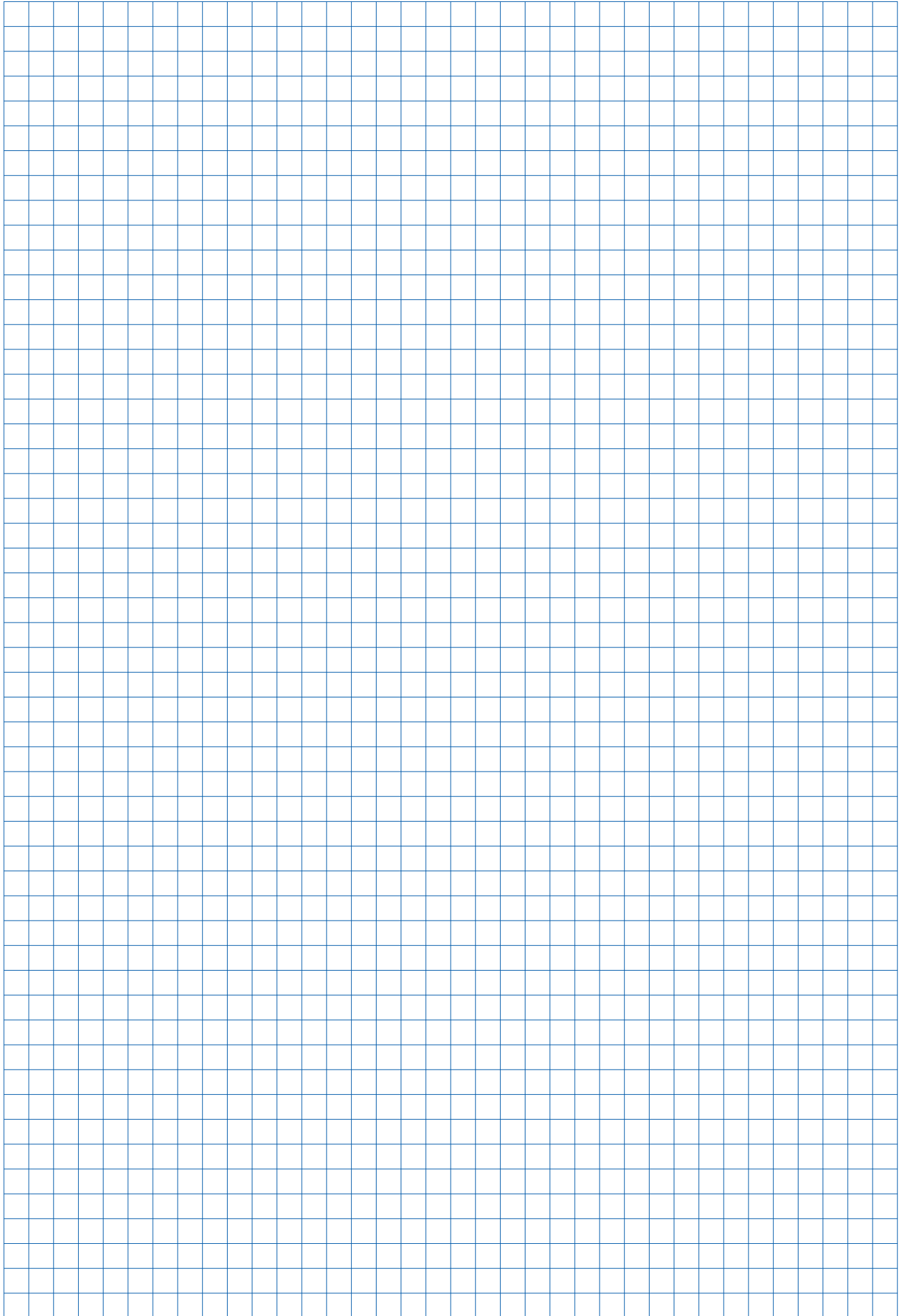

- E Tag-lines d10/5000 mm

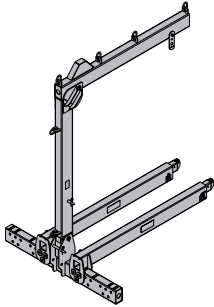

	[kg]	Article N°	[kg]	Article N°
<p>Transport fork 1.3t adjustable Umsetzgabel 1,3t verstellbar</p>  <p>Galvanised Delivery condition: folded closed Follow the directions in the "Operating Instructions"!</p>	718.0	586234000		
		CE		
<p>Transport-fork table-fixing part 1.3t adj. Tischfixierung Umsetzgabel 1,3t verstellbar</p>  <p>Galvanised Width: 21 cm Height: 21 cm</p>	5.0	586260000		

Declaration of conformity

 EC Declaration of Conformity pursuant to EC Directive 2006/42/EC.	
The manufacturer declares that by reason of its conception and design, the following product Transport fork 1.3t adjustable, art. n° 586234000 conforms – in the version marketed by ourselves – to the pertinent fundamental health and safety stipulations of the relevant EC Directives.	
The following harmonised standards were applied: <ul style="list-style-type: none"> ▪ EN ISO 12100:2010 ▪ EN 13155:2020 	
Person authorised to compile technical documentation (pursuant to European Directive on Machinery Annex II): Robert Hauser Josef Umdasch Platz 1 A-3300 Amstetten	
Amstetten, 19/01/2023	Doka GmbH Josef Umdasch Platz 1 A-3300 Amstetten
 Robert Hauser CEO	 Sebastian Dorda Vice President Strategy & Innovation