

The Formwork Experts.

Transport fork DM 1.5t adjustable

Art. n°: 586233000

Original Operating Instructions

Please retain for future reference

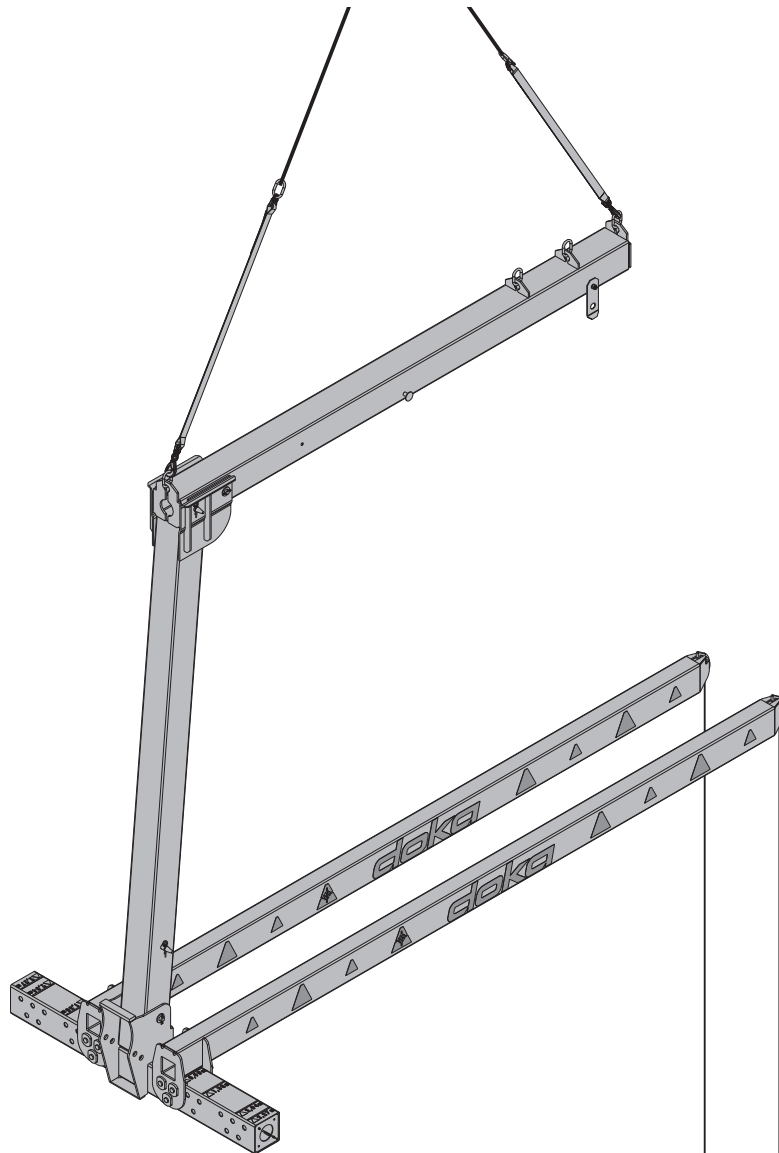

Contents

3	General
7	Preparation for use
12	Additional precautions
17	Repositioning operation
19	Dismantling
21	Article list

General

Intended use

The 'Transport fork DM 1.5t adjustable' is a lifting accessory. It is designed to be used for repositioning DokaXdek, Dokamatic and Dokaflex tables max. 8.0 m long (intended use).





NOTICE

- Other use or use not in conformity with that stated above is non-intended use and requires the prior written approval of the Doka company!
- Repositioning tables and platforms of other manufacturers is prohibited!
- The integrated lifting slings must not, under any circumstances, be used for any other purposes.



Follow the directions in the User Information booklet of the corresponding table!

Declaration of conformity

 EC Declaration of Conformity pursuant to EC Directive 2006/42/EC.	
The manufacturer declares that by reason of its conception and design, the following product Transport fork DM 1.5t adjustable, art. n° 586233000 conforms – in the version marketed by ourselves – to the pertinent fundamental health and safety stipulations of the relevant EC Directives.	
The following harmonised standards were applied: <ul style="list-style-type: none"> ▪ EN ISO 12100 ▪ EN 13155 	
Person authorised to compile technical documentation (pursuant to European Directive on Machinery, Annex II): Robert Hauser Josef Umdasch Platz 1 A-3300 Amstetten	
Amstetten, 06/03/2024	Doka GmbH Josef Umdasch Platz 1 A-3300 Amstetten
 Robert Hauser CEO	 Rainer Bolz Director Research & Development

Product presentation

Component overview

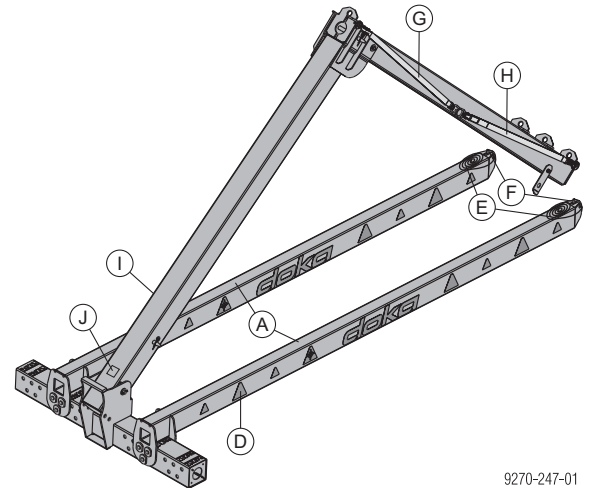

9270-247-01

A Fork profile (adjustable)

D Fork markings

E Tag-line d10/5000 mm

F Lever-latch

G Lifting sling 1

H Lifting sling 2

I Type plate

J Warning label

Safety notes (warning labels) on the product

- Danger of crushing!



Sizes

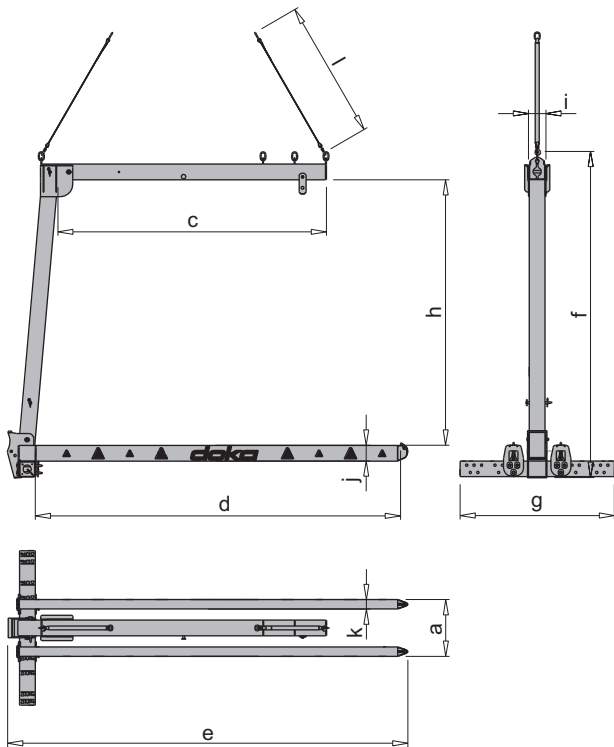

Delivery condition

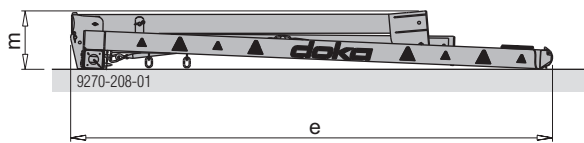

- a ... 90, 137, 204 or 227 cm
- c ... 426 cm
- d ... 580 cm
- e ... 635 cm
- f ... 517 cm
- g ... 245 cm
- h ... 421 cm
- i ... 27.6 cm
- j ... 25 cm
- k ... 15 cm
- l ... 220 cm
- m ... 77 cm

Data on type plate

- Art. n°: 586233000
- Designation: Transport fork DM 1.5t adjustable
- Dead weight: 1134 kg (2500 lbs)
- Permitted working load limit: 1500 kg (3300 lbs)
- Graph: Working load limit depending on load centre
- Max. permitted eccentricity when fully loaded: 15 cm
- Year of manufacture: see type plate
- Serial n°: see type plate
- QR code: Information on basis of serial numbers on id.doka.com

CE

Permitted working load limit

Working load limit depending on load centre

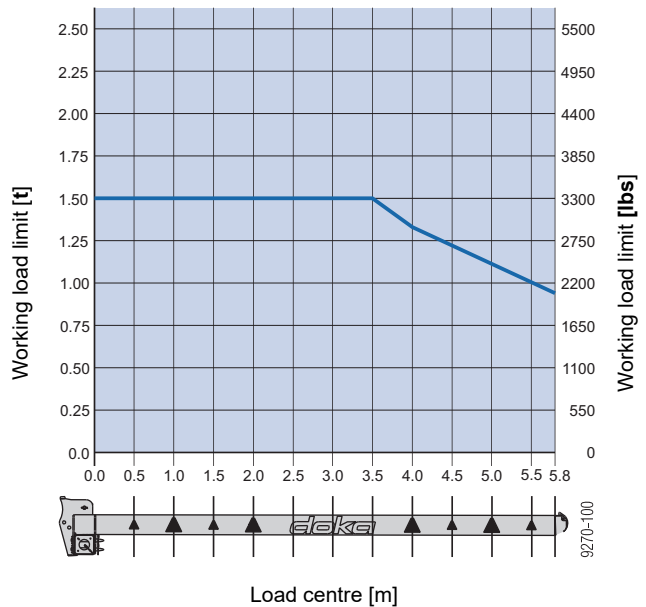

The permitted working load limit is valid up to the 3.5 m load centre offset point.

Max. permitted eccentricity when fully loaded:
15 cm

Maintenance / inspection / storage

Maintenance & inspection

- Repairs may only be carried out by the manufacturer!
- Doka accepts no liability for products that have been altered!

Before every use

- Check the transport fork and the lifting slings for damage and visible deformation.



Lifting accessories that do not meet the following criteria must be withdrawn from use immediately:

- Crack-free and notch-free welds.
- No deformation.
- The type plate and all adhesive labels must be in place, and must be clearly legible.

- If conditions are snowy and icy, also check the lifting slings for formation of ice crystals.

At regular intervals

- Inspection of lifting accessories must be performed at regular intervals by an **expert** in conformity with **national statutory provisions**. Unless otherwise stipulated, such inspection must be carried out **at least once a year**.

Storage

- Store lifting accessories in a dry and well ventilated place, protected from the weather and from all corrosive substances.

Selecting the lifting chain

Required **working load limit** of the 2-part lifting chain:

Up to 30° sling angle β : **4000 kg**

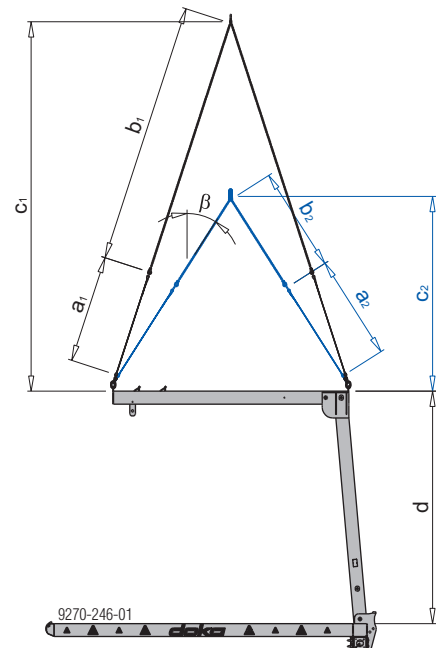

$a_1 = a_2 \dots 2.2 \text{ m}$
 $b_1 \dots 5.0 \text{ m}$ ($b_2 \dots 2.3 \text{ m}$)
 $c_1 \dots 6.8 \text{ m}$ ($c_2 \dots 3.9 \text{ m}$)
 $d \dots 4.5 \text{ m}$
 $\beta \dots \text{max. } 30^\circ$



NOTICE

- Always fasten the 2-part chain to the rear lifting point and to one of the front lifting points, as necessitated by the centre-of-gravity position.
- Sling angle β max. 30°!
- The longer the crane lifting tackle (2-part lifting chain), the more easily the transport fork will hang in the horizontal, both when under load and when not under load.
- Recommended length of crane lifting tackle min. 5.0 m + lifting sling 2.2 m.
- For tables over 5.0 m long, extend the rear lifting chains by approx. 1.0 m to keep these tables in a horizontal position while they are being lifted. Always check this before the device is used for the first time on a new site.



If the lifting height of the crane is not sufficient in the top storey, shorter lifting chains may be used, provided that the following points are observed.

- Sling angle β max. 30°!
- Length of the crane lifting tackle min. 2.3 m + lifting sling 2.2 m.
- Use chains with adjustable lengths.

Functional description

'Parked' position

Attaching/detaching the 2-part lifting chain is easy, as the bracket automatically tilts down into the parked position when it is placed on the ground.

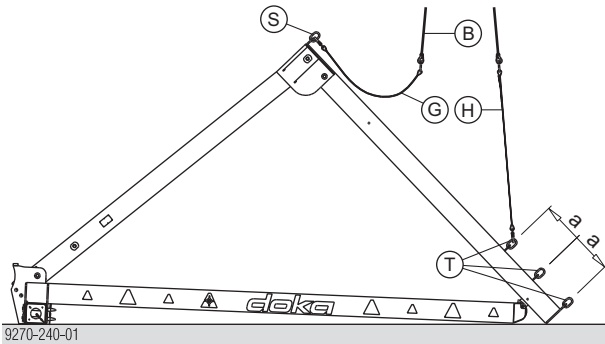

a ... adjusting range for centre-of-gravity position

- B** 2-part lifting chain
- G** Lifting sling 1
- H** Lifting sling 2
- S** Chainlink A16 (rear lifting point for lifting sling 1)
- T** Chainlink A16 (front lifting points for lifting sling 2)

Possible operator error



WARNING

Danger of crushing!

- It is forbidden to raise the transport fork (e.g. by forklift truck or lifting slings) from underneath the fork profiles!

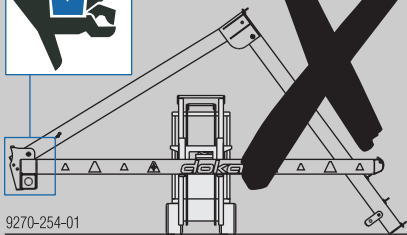

9270-254-01

Lever-latch

The lever-latch acts as an anti-slide-off guard when DokaXdek, Dokamatic and Dokaflex tables are being lifted.

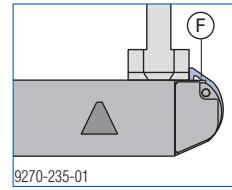

9270-235-01

F Lever-latch

Tag-lines

The tag-lines make it easier and safer to guide the transport fork when manoeuvring it under the Doka tableforms.

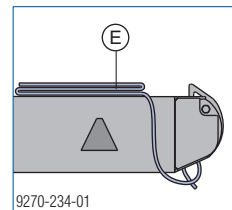

9270-234-01

E Tag-line d10/5000 mm

Fork markings

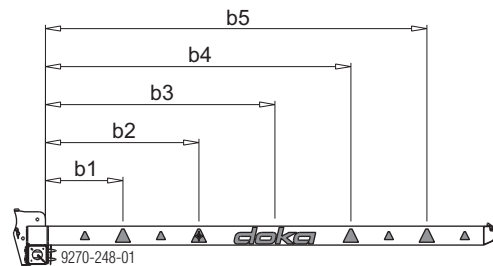

9270-248-01

- b1 ... 100 cm
- b2 ... 200 cm (centre-of-gravity mark)
- b3 ... 300 cm
- b4 ... 400 cm
- b5 ... 500 cm

Note:

For every lifting operation, it is desirable to position the table as near as possible to the horizontal.

Once you know the ideal position on the fork for a certain table, it is easy to repeat this position on subsequent tables of the same type, by referring to the markings on the fork.

These markings are also a highly visible safety warning to the site crew when the fork is hovering in the air.

Preparation for use

Offloading on the site



- ▶ During the crane operation, all persons must stay a safe distance away from the transport fork to avoid unsafe conditions and eliminate any hazards or exposure to injury!

Dokamatic lifting strap 13.00m

- ▶ Offload the transport fork from the truck using 2 Dokamatic lifting straps 13.00m.

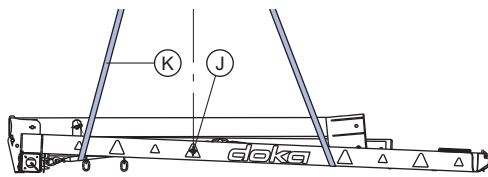

9270-241-01

J Centre-of-gravity mark

K Dokamatic lifting straps 13.00m

Using the integrated lifting slings

The lifting slings enable the job of attaching the crane lifting tackle to the transport fork to be done from ground level and ensure horizontal offloading of the transport fork.

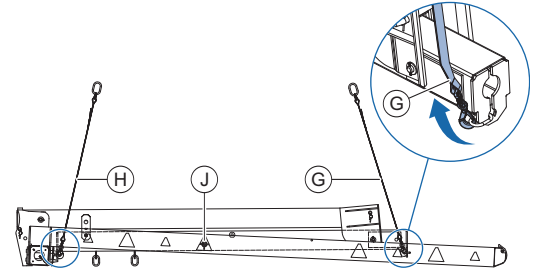

9270-242-01

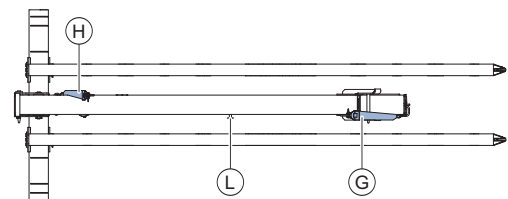

G Lifting sling 1

H Lifting sling 2

J Centre-of-gravity mark

L 'Parked' position for lifting slings

Offloading from truck:

- ▶ Detach both lifting slings from the 'parked' position.
- ▶ Hook lifting sling 2 into the first crane hook.
- ▶ Swing lifting sling 1 to the opposite side of the Lifting extension bracket and hook it into the second crane hook.
- ▶ Offload the transport fork from the truck.

Assembly



- ▶ During the crane operation, all persons must stay a safe distance away from the transport fork to avoid unsafe conditions and eliminate any hazards or exposure to injury!

- ▶ Set the fork down on level ground.
- ▶ Remove the fork bolt D37 from Pos. 1.

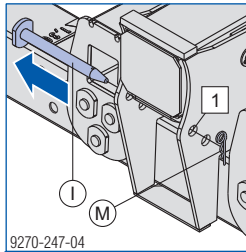

- I Fork bolt D37
- M Spring cotter D6

- ▶ Detach lifting sling 1 from the 'parked' position.

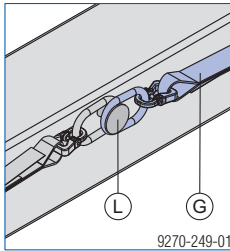

- G Lifting sling 1
- L 'Parked' position for lifting slings

- ▶ Hook lifting sling 1 into the crane hook of the first strand of the 2-part lifting chain.

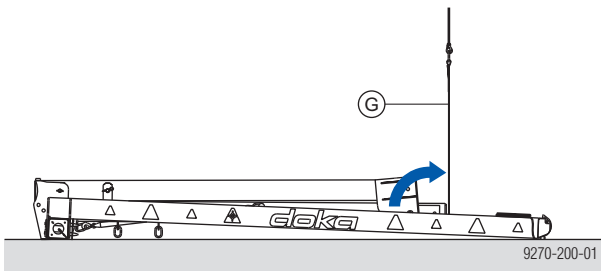

- G Lifting sling 1

- ▶ Raise the lifting extension bracket by crane.

- ▶ Insert the fork bolt D37 (previously removed from Pos. 1) into Pos. 2, and fix it with a Spring cotter D6.

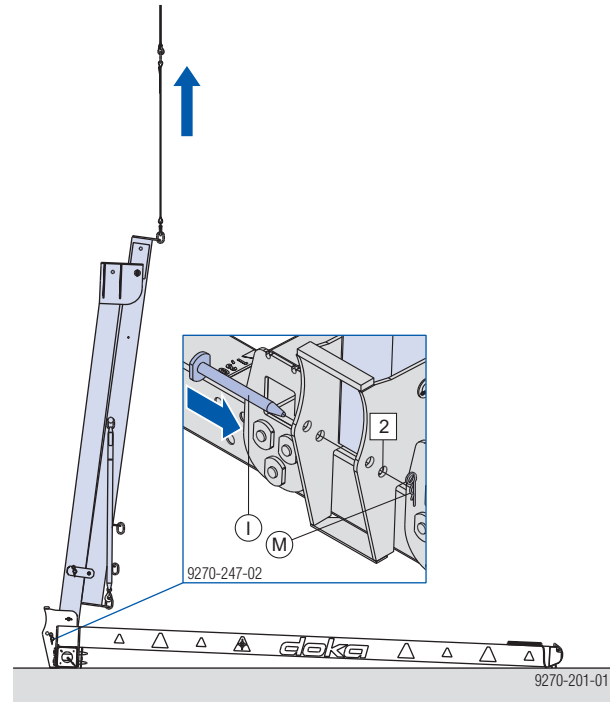

- I Fork bolt D37
- M Spring cotter D6

- ▶ Remove the fork bolt D37 from Pos. 1. The lifting extension-bracket tube will now tilt towards the front.

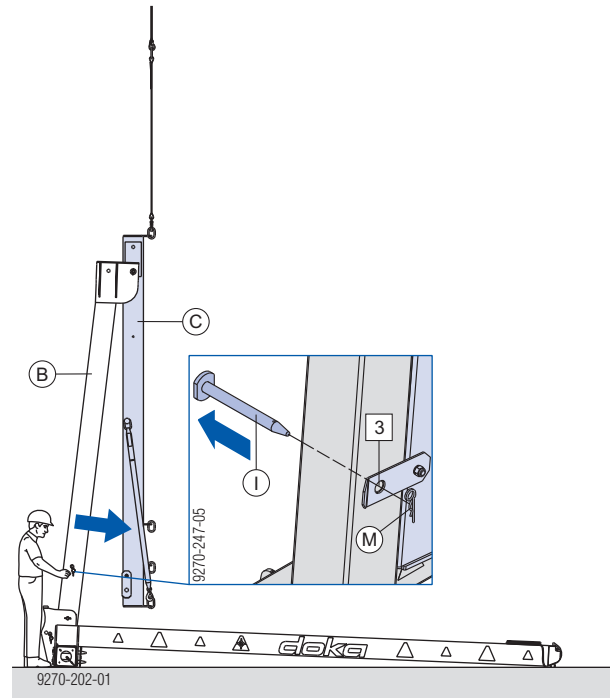

- B Upright tube
- C Lifting extension-bracket tube
- I Fork bolt D37
- M Spring cotter D6

- ▶ Push the fork bolt D37 back into Pos. 3 on the upright tube, and fix it with a Spring cotter D6.

- ▶ Lower the lifting chains until the crane hook of the second strand of the 2-part lifting chain is within reach of lifting sling 2.
- ▶ Detach lifting sling 2 from the 'parked' position and hook it into the crane hook.

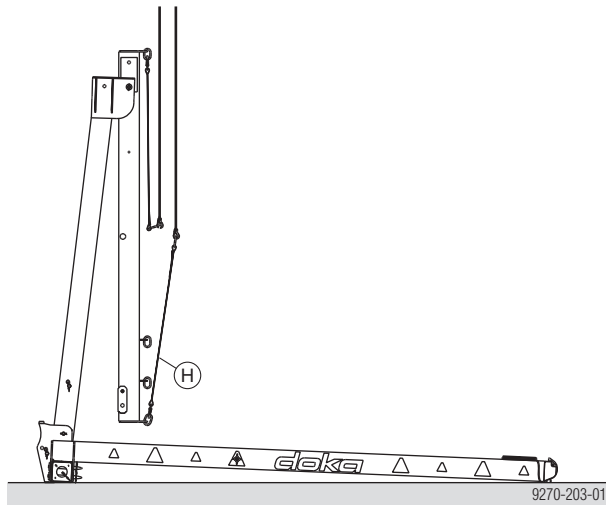
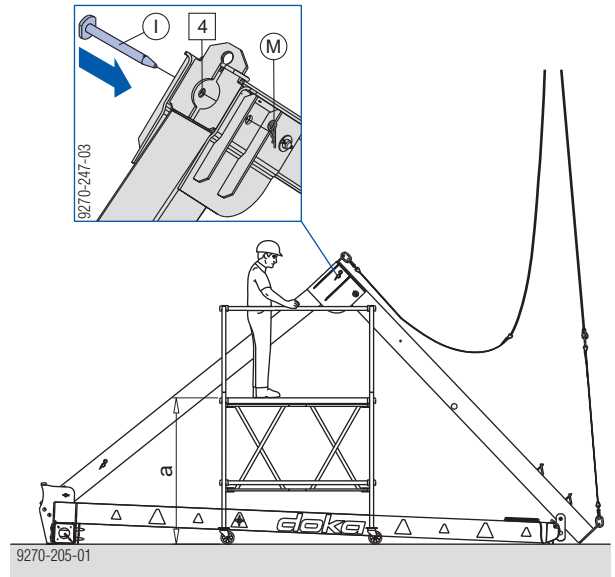
**H** Lifting sling 2

a ... approx. 2000 mm

I Fork bolt D37**M** Spring cotter D6

- ▶ The transport fork is now ready for operation.

Note:

No fork bolt is allowed in Pos. 2 at any time while the transport fork is in use!

- ▶ Raise the entire transport fork by crane. The transport fork is now suspended above the ground.
- ▶ Remove the fork bolt D37 from Pos. 2.

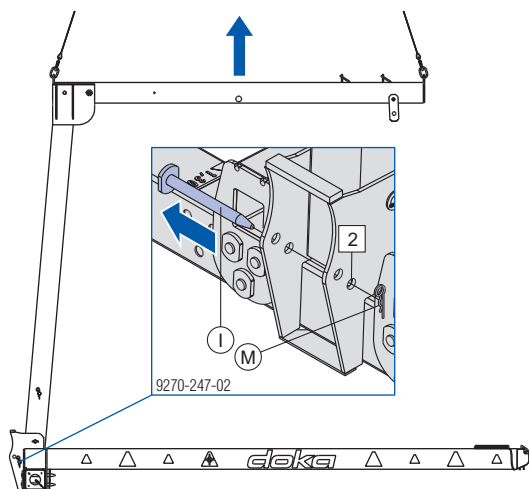

9270-204-01

I Fork bolt D37**M** Spring cotter D6

- ▶ Set down the transport fork and carefully lower the lifting extension bracket into the 'parked' position.
- ▶ Insert the fork bolt D37 (previously removed from Pos. 2) into Pos. 4, and fix it with a Spring cotter D6. The articulated joint on the lifting extension bracket is now locked.

Note:

A wheel-around scaffold is needed for doing this.

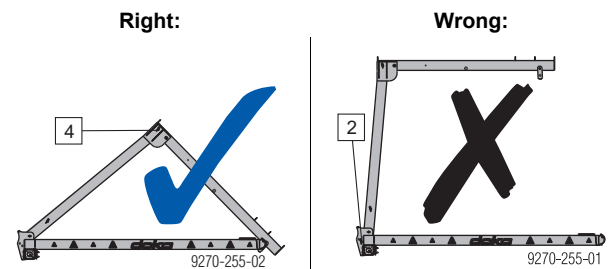

Setting the fork width

Fork width has to be adjusted to suit the type of table and the table's orientation relative to the fork. There are 4 possible fork width settings (a1 - a4).

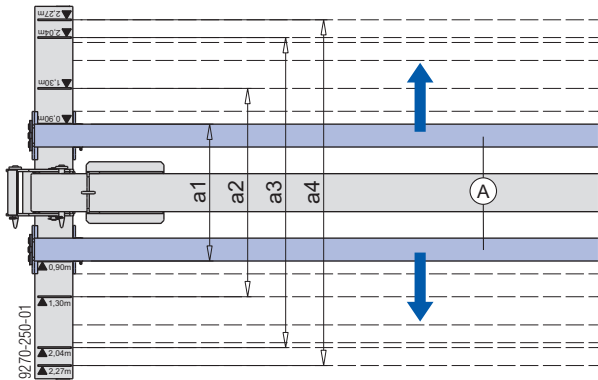

- a1 ... 90 cm
- a2 ... 137 cm
- a3 ... 204 cm
- a4 ... 227 cm

A Fork profile



- ▶ Always adjust the fork profiles one at a time.
- ▶ The fork profiles must always be positioned symmetrically.



NOTICE

- The transport fork must be resting on level ground, with the lifting extension bracket in the 'parked' position.

- ▶ Remove all three fork bolts D37 from Pos. 8.
- ▶ Keeping the first fork profile parallel with the second fork profile, move it as far as the desired width-mark.
- ▶ Bolt all three fork bolts D37 into Pos. 8, and fix with the Spring cotter d6.

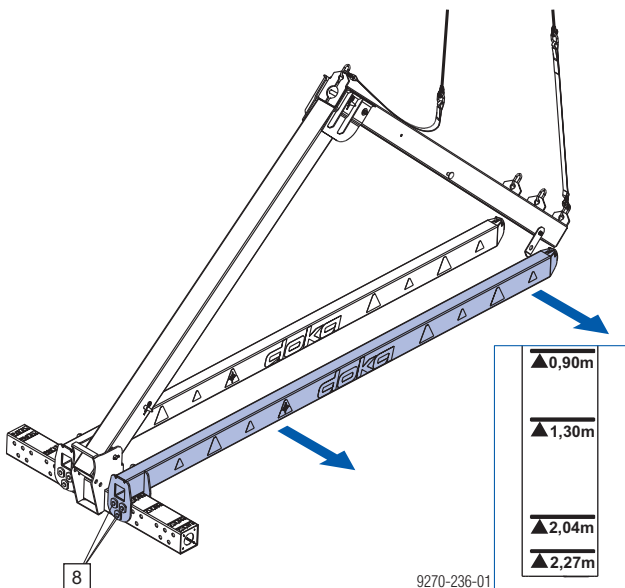

- ▶ Keeping the second fork profile parallel with the first, move it as far as the corresponding width-mark.

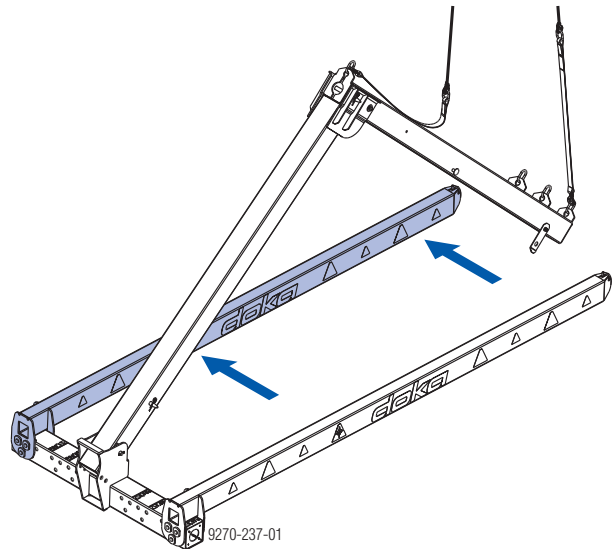

Setting fork width for standard tables

Fork widths needed for repositioning standard tables

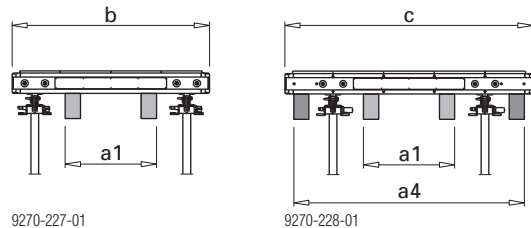

Practical example, Dokamatic table

Fork width

Table type	Table width			
	200 (b)	250 (c)	195 (b)	245 (c)
DokaXdek table	90 (a1)	90 (a1) 227 (a4)	—	—
Dokamatic table	—	—	90 (a1)	90 (a1) 227 (a4)
Dokaflex table	—	—	90 (a1)	90 (a1) 227 (a4)

Dimensions in cm

Setting fork width for tables with Staxo

Fork widths needed for repositioning tables with Staxo

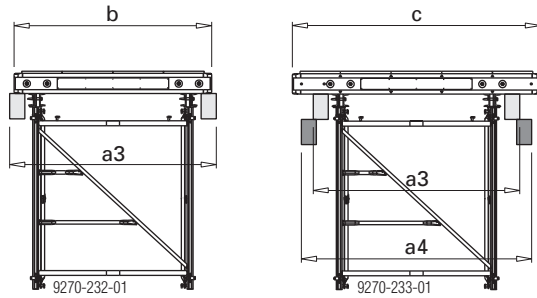

Practical example, Dokamatic table

Fork width

Table type	Table width			
	200 (b)	250 (c)	195 (b)	245 (c)
DokaXdek table	204 (a3)	204 (a3) 227 (a4)	—	—
Dokamatic table	—	—	204 (a3)	204 (a3) 227 (a4)

Dimensions in cm

Setting fork width for tables with table frame



NOTICE

Tables with Table frame 1.50m or Dokamatic table frame 1.50m must always be picked up with the forks on the outside, under the project beams.

Fork widths needed for repositioning tables with table frame

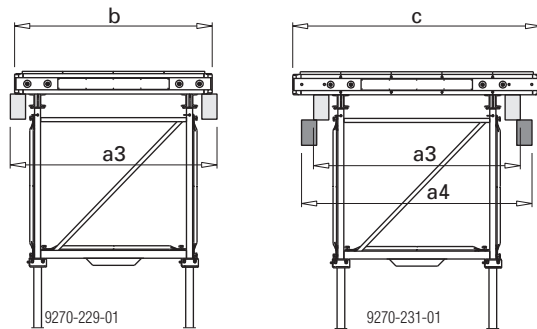

Practical example, Dokamatic table

Fork width

Table type	Table width			
	200 (b)	250 (c)	195 (b)	245 (c)
DokaXdek table	204 (a3)	204 (a3) 227 (a4)	—	—
Dokamatic table	—	—	204 (a3)	204 (a3) 227 (a4)
Dokaflex table	—	—	—	227 (a4)

Dimensions in cm

Exception, 'forks underneath the table frame'

If fork width corresponds to the as-delivered condition (a1=90 cm), the forks can be positioned underneath the table frame.



WARNING

- ▶ The table frame must be tightly strapped to the transport fork with lashing straps, otherwise the tableform might tip over!
- ▶ A wheel-around scaffold is required for mounting the lashing straps.

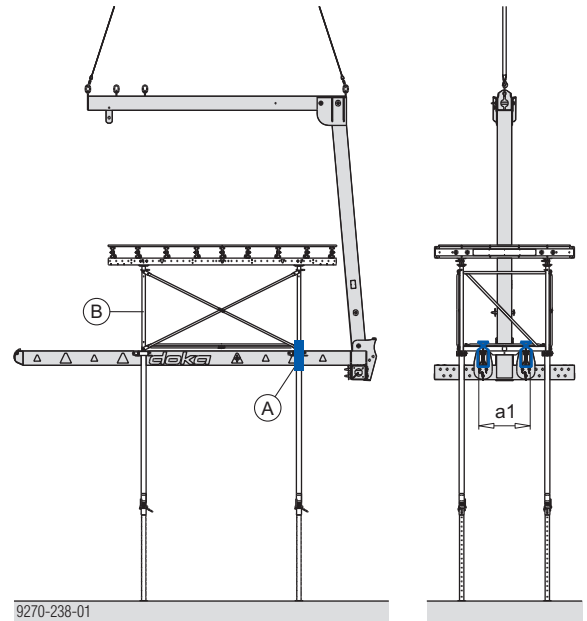

Practical example, Dokamatic table
a1 ... 90 cm

A Lashing strap

B Table frame 1.50m or Dokamatic table frame 1.50m

Working load limit of the lashing straps: min. 2000 kg

Additional precautions

Edge table with drop-beam formwork

Extra precaution:

Doka beams H20 are mounted to the fork profile, along the direction of the fork (required for DokaXdek, Dokamatic and Dokaflex tables).



WARNING

Tableform falling-hazard!

Using the Doka beams H20 in this way deactivates the lever-latch so that it no longer acts as an anti-slide-off guard.

- ▶ Do not use the transport fork for regular lifting operations if Doka beams H20 are mounted to it!

Downstand beam up to 20 cm high

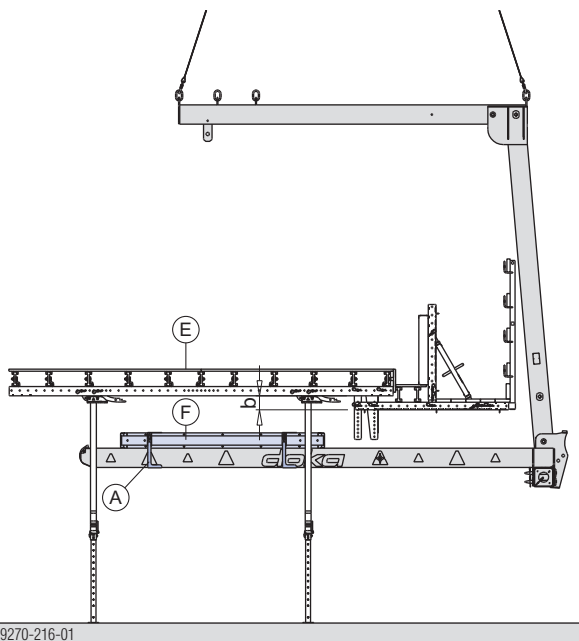

9270-216-01

b ... max. 20 cm

- A** Extension clamp H20 for fork
- E** Edge table with downstand beam
- F** Doka beam H20 2.65m

- ▶ Place a Doka beam H20 on the fork.
- ▶ Slide the vertical-extension angle of the extension clamp onto the fork profile.

- ▶ Place the connecting plate of the extension clamp over the Doka beam H20 and attach it tightly to the vertical-extension angle with the hexagon nut.

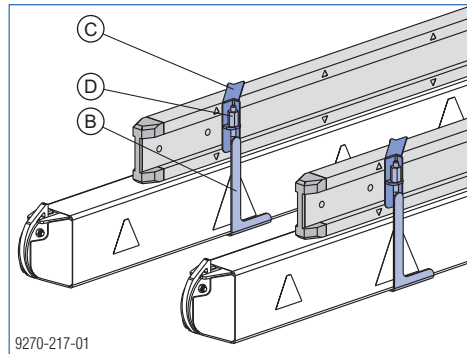

9270-217-01

- B** Vertical-extension angle
- C** Connecting plate
- D** Hexagon nut 15.0 (width-across flats 30 mm)

Downstand beam up to 60 cm high

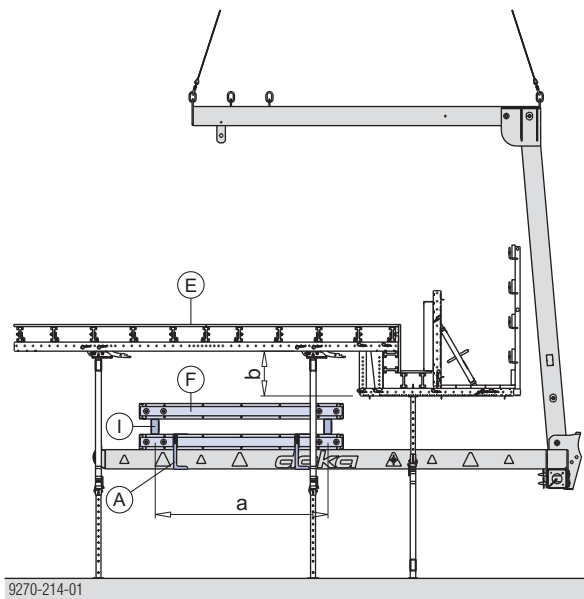

9270-214-01

a ... 225 cm
b ... max. 60 cm

- A** Extension clamp H20 for fork
- I** Extension profile H20 for fork
- E** Edge table with downstand beam
- F** Doka beam H20 2.65m

- Set down two extension profiles H20 on the ground, in the vertical.
- Screw 4 Doka beams H20 2.65m firmly to the extension profiles.

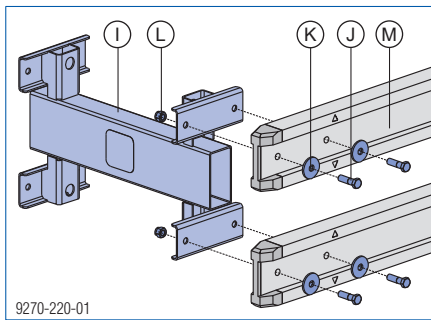

- I** Extension profile H20 for fork
- J** Hexagon bolt ISO 4014 M20x70 8.8
- K** Washer R22
- L** Hexagon nut ISO 7040 M20 self-locking
- M** Doka beam H20 2.65m (4 beams)



NOTICE

Mounting of the Extension profile H20 is only permitted when the fork is set to a width of 90 cm!

- Set the fork width to 90 cm.
- Place the pre-assembled unit onto the transport fork and mount it with the extension clamp.

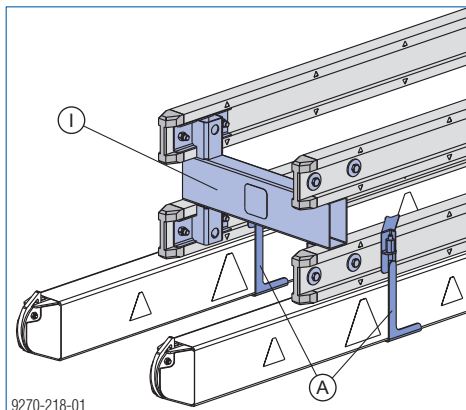

- A** Extension clamp H20 for fork
- I** Extension profile H20 for fork

Lifting tables at right angles to the direction of the fork

DokaXdek tables

Extra precaution:

Doka beams H20 are mounted to the fork profile, at right-angles to the direction of the fork.



WARNING

Tableform falling-hazard!

Using the Doka beams H20 in this way deactivates the lever-latch so that it no longer acts as an anti-slide-off guard.

- Do not use the transport fork for regular lifting operations if Doka beams H20 are mounted to it!

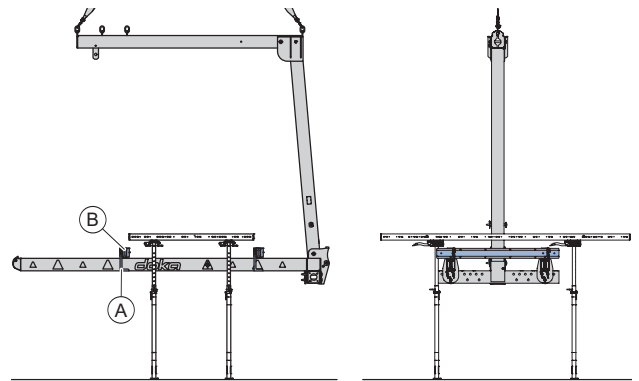

- A** Extension clamp H20 for fork
- B** Doka beam H20

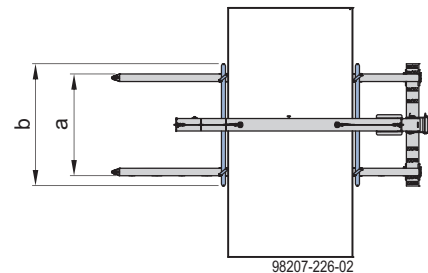

- a ... fork width 1.37 m for table width 4.00m
- a ... fork width 2.04 m for table width 5.00m
- b ... beam length of extension 1.80 m for table width 4.00m
- b ... beam length of extension 2.45 m for table width 5.00m

Installation:

- Place a Doka beam H20 on the fork.
- Slide the vertical-extension angle of the extension clamp onto the fork profile.
- Place the connecting plate of the extension clamp over the Doka beam H20 and attach it tightly to the vertical-extension angle with the hexagon nut.

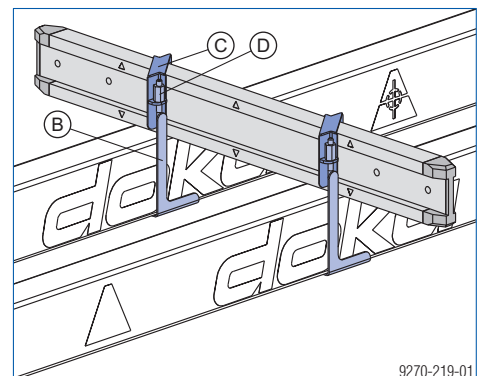

- B** Vertical-extension angle
- C** Connecting plate
- D** Hexagon nut 15.0 (width-across flats 30 mm)

Dokamatic tables

Extra precaution:

Doka beams H20 are mounted to the fork profile, at right-angles to the direction of the fork (for installation see the section headed 'DokaXdek table').



WARNING

Tableform falling-hazard!

Using the Doka beams H20 in this way deactivates the lever-latch so that it no longer acts as an anti-slide-off guard.

- ▶ Do not use the transport fork for regular lifting operations if Doka beams H20 are mounted to it!

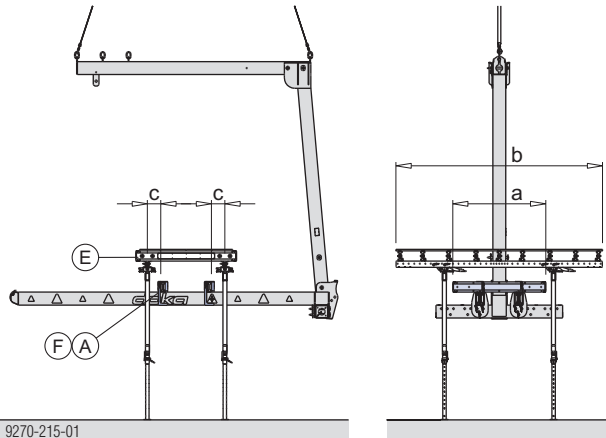

9270-215-01

a ... beam length = min. $\frac{b}{3}$ (max. 1.80 m)

b ... table length

c ... max. 30 cm

A Extension clamp H20 for fork

E Dokamatic table

F Doka beam H20

Dokaflex tables

Extra precaution:

- Wide Dokaflex tables must be secured, e.g. with tension straps, tension chains, etc.
- If table width is less than 3 times the fork width, the table does not need to be secured.

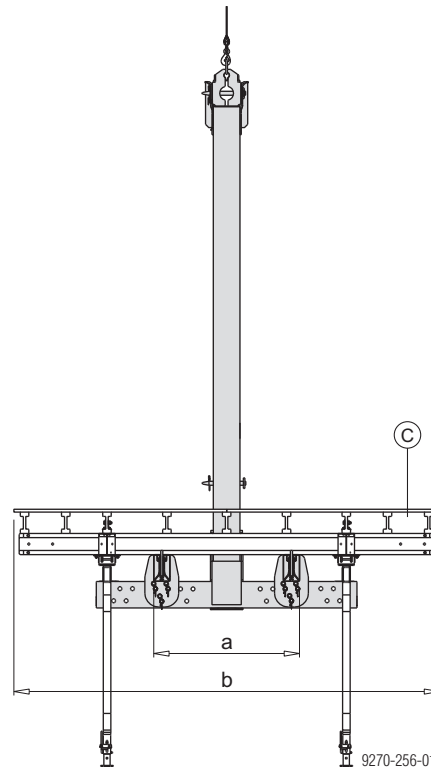

9270-256-01

a ... fork width

b ... max. 3 x fork width a

C Dokaflex table

Lifting tables over two storeys

Extra precaution:

The lifting extension bracket of the transport fork is lengthened with the Vertical extension DM 3.30m.

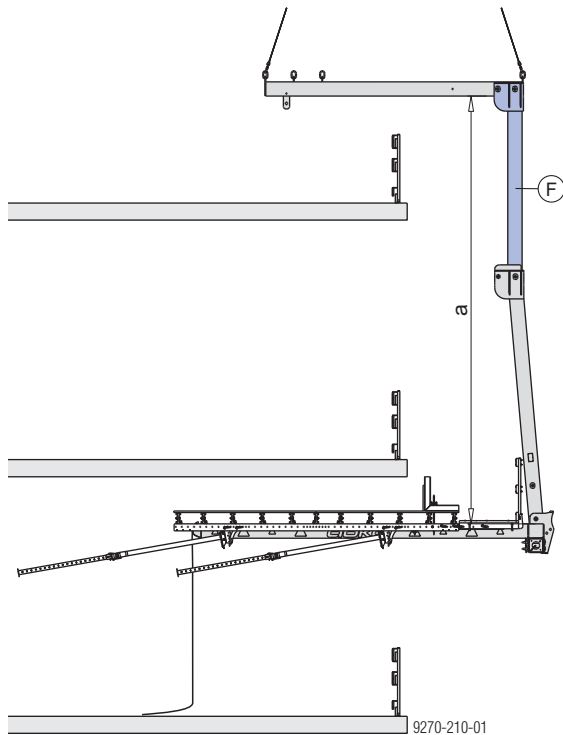

a ... 750 cm

F Vertical extension DM 3.30m

Mounting the Vertical extension



- ▶ During the crane operation, all persons must stay a safe distance away from the transport fork to avoid unsafe conditions and eliminate any hazards or exposure to injury!

Note:

Spring cotters d6 are used on the fork axle instead of the cotter pins. The spring cotters are found at either end of the fork adjusting profile (spares).

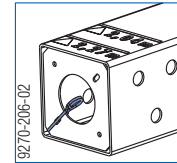

- ▶ Set the fork down on level ground.
- ▶ Remove the fork bolt D37 from Pos. 1.
- ▶ Detach lifting sling 1 from the 'parked' position.
- ▶ Hook lifting sling 1 into the crane hook of the first strand of the 2-part lifting chain.

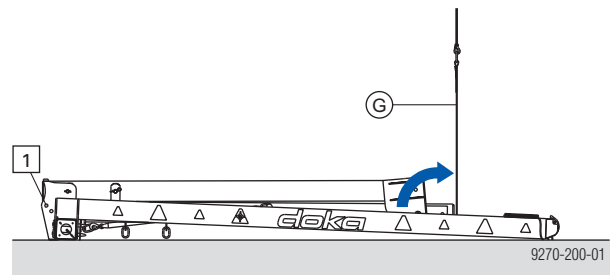

G Lifting sling 1

- ▶ Raise the lifting extension bracket by crane.
- ▶ Remove the fork axle D37 from Pos. 5.

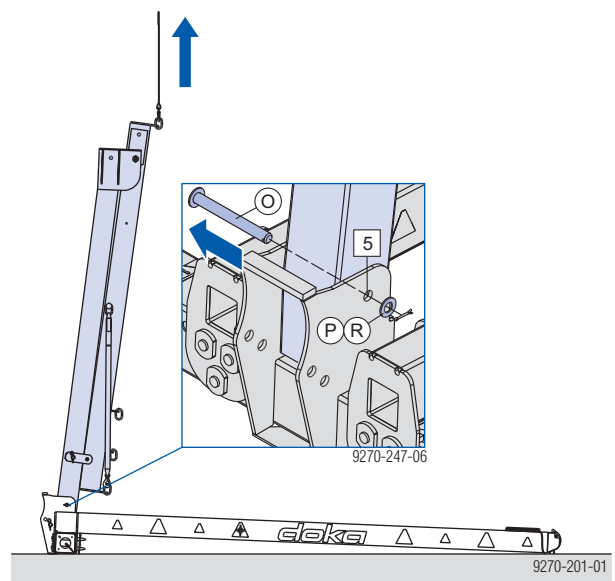

O Fork axle D37

P Axle washer

R Cotter pin

- Lift the lifting extension bracket all the way out of the fork adjusting profile and set it down on squared timbers on the ground.
- Remove the fork bolt D37 from Pos. 3.
- Remove the fork axle D37 from Pos. 6.
- Separate the lifting extension-bracket tube from the upright tube.
- Push the fork bolt D37 back into Pos. 3 on the upright tube, and fix it with a Spring cotter D6.

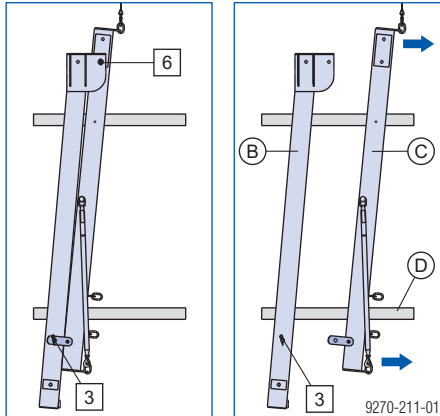

- B** Upright tube
- C** Lifting extension-bracket tube
- D** Squared timber

➤ **Connect the vertical extension to the upright tube.**

- Fix the fork axle D37 in Pos. 6. Fix on an axle washer and secure this with a Spring cotter d6.
- Insert the fork bolt D37 into Pos. 4 and fix it with a Spring cotter D6.
- Remove both the fork bolts D37 of the vertical extension from Pos. 7.

➤ **Connect the vertical extension to the lifting extension-bracket tube.**

- Fix both fork bolts D37 back into Pos. 7 and secure them with Spring cotters D6.

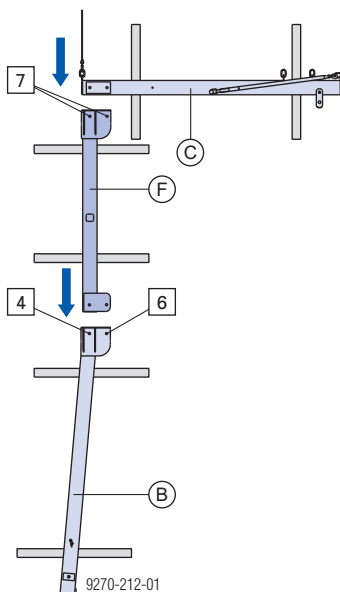

- B** Upright tube
- C** Lifting extension-bracket tube
- F** Vertical extension DM 3.30m

- Hook lifting sling 1 into the crane hook of the first strand of the 2-part lifting chain.
- Raise the lifting extension bracket plus vertical extension, and introduce it into the fork adjusting profile.
- Insert the fork axle D37 into Pos. 5, fix on an axle washer and secure with a Spring cotter d6.

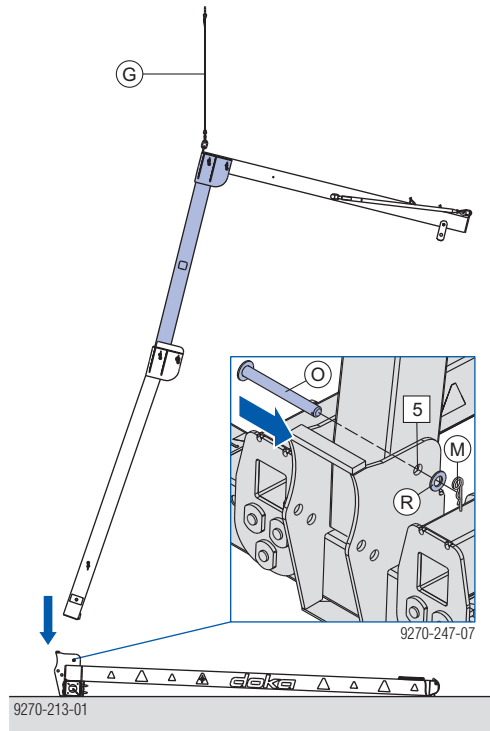

- G** Lifting sling 1
- M** Spring cotter D6
- O** Fork axle D37
- R** Axle washer

- Lower the lifting chains until the crane hook of the second strand of the 2-part lifting chain is within reach of lifting sling 2.
- Detach lifting sling 2 from the 'parked' position and hook it into the crane hook.

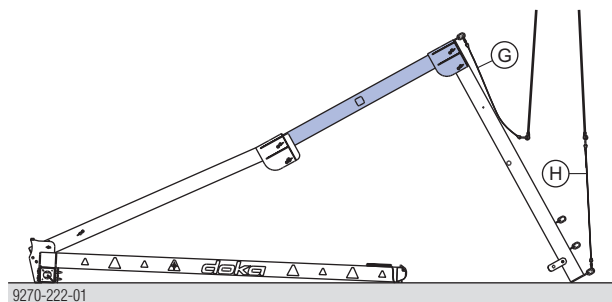

- G** Lifting sling 1
- H** Lifting sling 2

- The transport fork is now ready for operation.

Repositioning operation



WARNING

Risk of intermediate props dropping out when table is lifted

- ▶ **Intermediate props** with a Supporting head H20 DF, and props that are only secured against tipping over, must be **removed** before the table is lifted.
- ▶ Intermediate props that are attached by an **Intermediate head DF** and are not dis-mounted must be pulled in sufficiently far.



WARNING

- ▶ 'Passenger transportation' is forbidden!
- ▶ Additional safety measures are needed for special, custom table constructions.
- ▶ Before repositioning the tableform, remove all loose items (e.g. fitting boards) from it.
- ▶ Check the connections between the floor props and the tableform before repositioning the table.
- ▶ Before lifting, fix the floor props with the fastening clamps.



- ▶ During the crane operation, all persons must stay a safe distance away from the transport fork to avoid unsafe conditions and eliminate any hazards or exposure to injury!



Follow the directions in the 'DoKart plus' Operating Instructions!

- ▶ Wheel the table to the pick-up point with the DoKart plus.

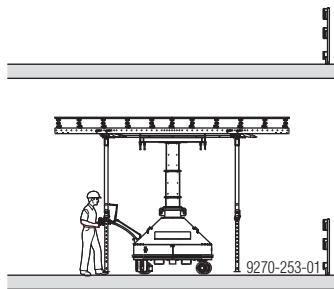

- ▶ Set the table down.
- ▶ Wheel out the DoKart plus from under the table (the next table can now be prepared for repositioning).

- ▶ Detach both lifting slings from the 'parked' position and hook them into the crane hook.

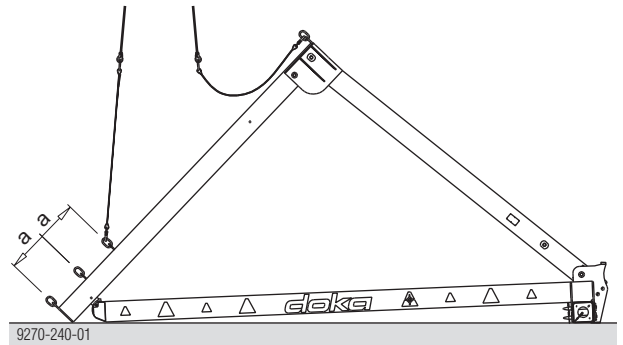

a ... adjusting range for centre-of-gravity position

- ▶ Raise the transport fork by crane.
- ▶ Manoeuvre the transport fork under the table.

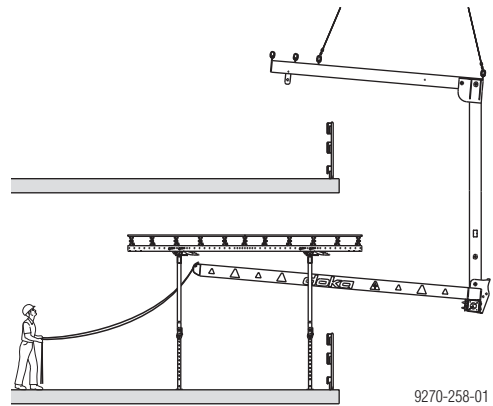

- ▶ Pick up the table with the transport fork, move it out and lift it.

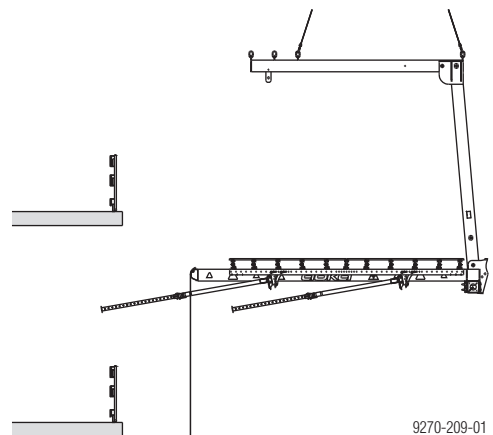

- ▶ Set the table down at its new location.

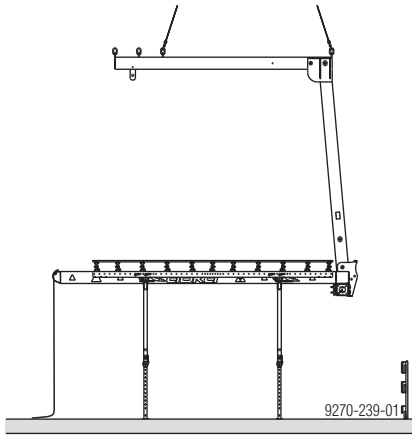
**WARNING**

- ▶ Check the connections between the floor props and the tableform before setting it down.
- ▶ Before setting the table down, check whether the floor props have been fixed with the fastening clamps.

Dismantling



- ▶ During the crane operation, all persons must stay a safe distance away from the transport fork to avoid unsafe conditions and eliminate any hazards or exposure to injury!

The lifting extension bracket is in the 'parked' position.

- ▶ Remove the fork bolt D37 from Pos. 4. Wheel-around scaffold necessary!

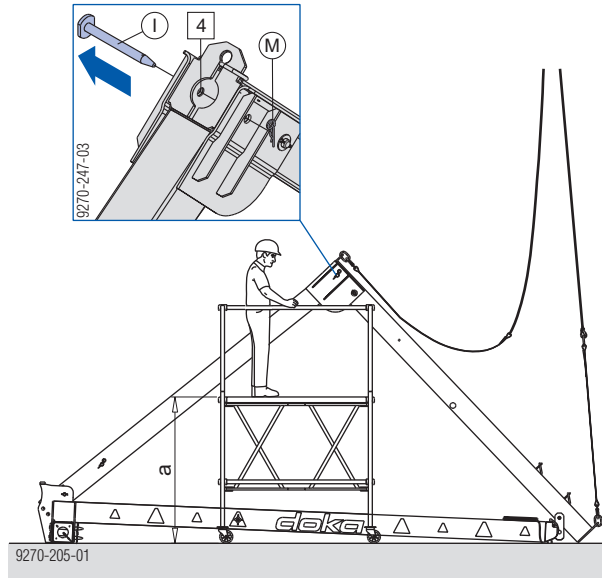

a ... approx. 200 cm

I Fork bolt D37

M Spring cotter D6

- ▶ Raise the entire transport fork by crane. The transport fork is now suspended above the ground.
- ▶ Insert the fork bolt D37 (previously removed from Pos. 4) into Pos. 2, and fix it with a Spring cotter D6.

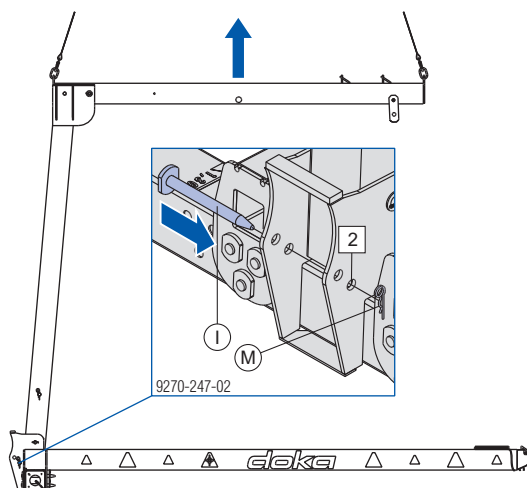

9270-204-01

I Fork bolt D37

M Spring cotter D6

- ▶ Lower the lifting extension-bracket tube.

- ▶ Lower the lifting chains until the crane hook of the second strand of the 2-part lifting chain is within reach of lifting sling 2.

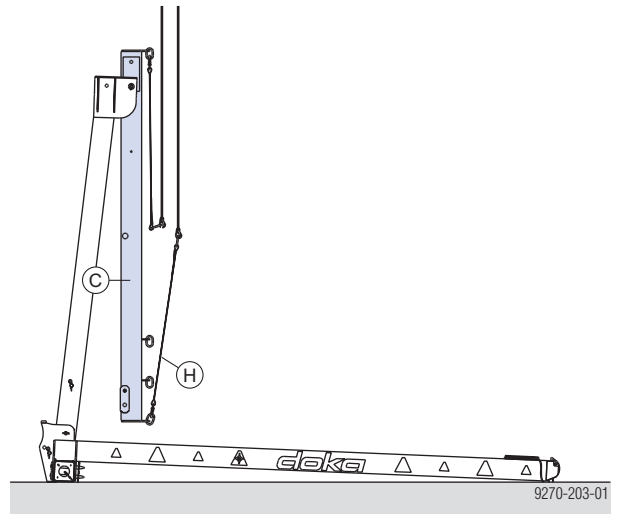

C Lifting extension-bracket tube

H Lifting sling 2

- ▶ Detach lifting sling 2 from the crane hook and re-attach it in the 'parked' position.
- ▶ Remove the fork bolt D37 from Pos. 3.
- ▶ Connect the lifting extension-bracket tube to the upright tube, insert the fork bolt D37 back into Pos. 3 and fix it with the Spring cotter D6.

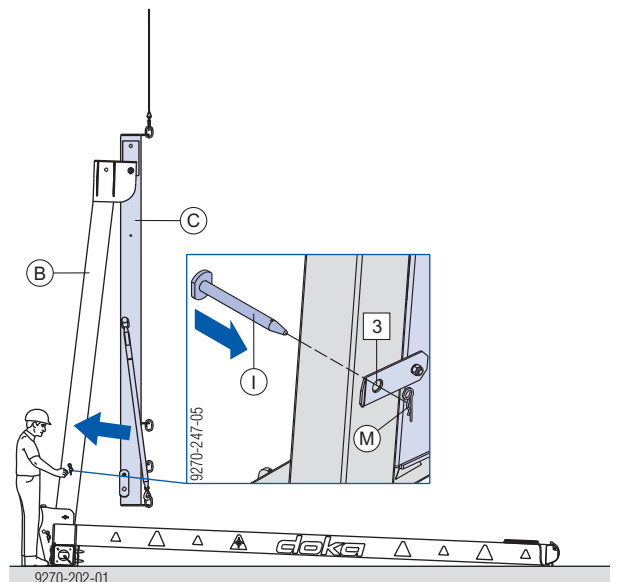

B Upright tube

C Lifting extension-bracket tube

I Fork bolt D37

M Spring cotter D6

- Remove the fork bolt D37 from Pos. 2.

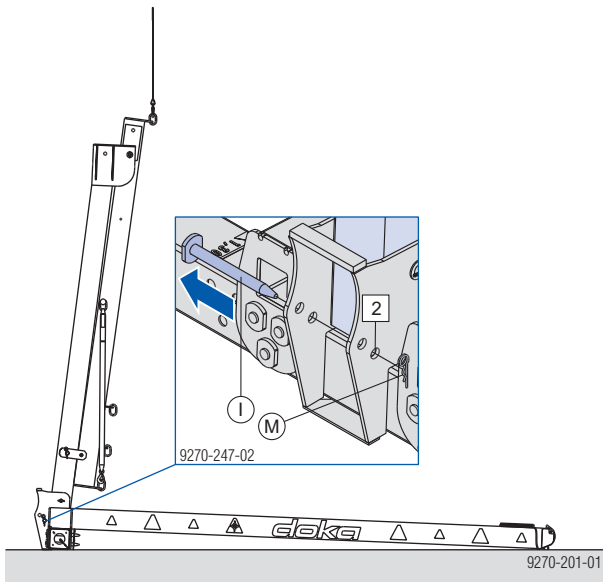

- I** Fork bolt D37
- M** Spring cotter D6

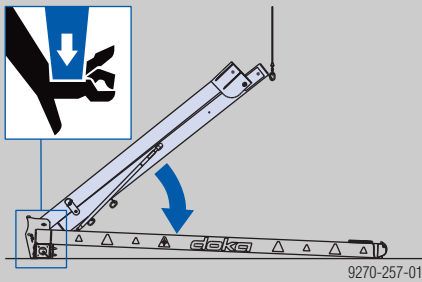

! WARNING
Danger of crushing!
 ➤ Mind your hands!

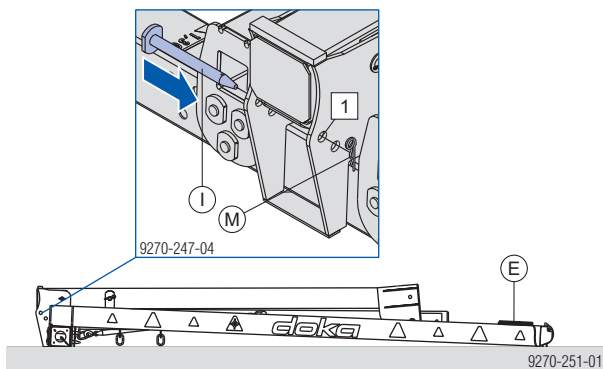

- Lower the lifting extension bracket to the ground by crane.
- Detach lifting sling 1 from the crane hook and re-attach it in the 'parked' position.
- Insert the fork bolt D37 (previously removed from Pos. 2) into Pos. 1 as a transport lock, and fix it with the Spring cotter D6.
- Bundle the tag-lines together so that they can be transported safely.

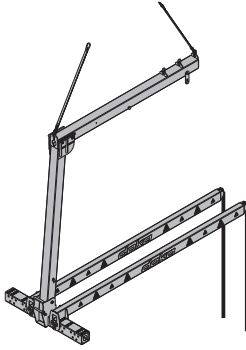

- E** Tag-lines
- I** Fork bolt D37
- M** Spring cotter D6

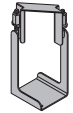
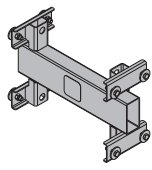
	[kg]	Article N°	[kg]	Article N°
Transport fork DM 1.5t adjustable Umsetzgabel DM 1,5t verstellbar  <p>Galvanised Delivery condition: folded closed Follow the directions in the "Operating Instructions"!</p>	1134.0	586233000		
CE				
Vertical extension DM 3.30m Vertikalverlängerung DM 3,30m  <p>Galvanised Height: 352 cm</p>	240.0	586235000		
Extension clamp H20 for fork Aufsatzklemme H20 für Gabel  <p>Galvanised Height: 45 cm</p>	4.5	586236000		
Extension profile H20 for fork Aufsatzprofil H20 für Gabel  <p>Galvanised Length: 83 cm Height: 52 cm</p>	34.1	586237000		

Near to you, worldwide

Doka is one of the world leaders in developing, manufacturing and distributing formwork technology for use in all fields of the construction sector.

With more than 160 sales and logistics facilities in over 70 countries, the Doka Group has a highly efficient distribution network which ensures that equipment and

technical support are provided swiftly and professionally.

An enterprise forming part of the Umdasch Group, the Doka Group employs a worldwide workforce of more than 6000.

